

A DICTIONARY
OF
ELECTRICAL WORDS,
TERMS AND PHRASES.

BY
EDWIN J. HOUSTON, A.M., Ph.D. (Princeton),
EMERITUS PROFESSOR OF NATURAL PHILOSOPHY AND PHYSICAL GEOGRAPHY IN THE CENTRAL
HIGH SCHOOL OF PHILADELPHIA; PROFESSOR OF PHYSICS IN THE FRANKLIN
INSTITUTE OF PENNSYLVANIA; ELECTRICIAN OF THE INTER-
NATIONAL ELECTRICAL EXHIBITION,
ETC., ETC.

FOURTH EDITION. WITH APPENDIX. GREATLY ENLARGED.

NEW YORK:
THE W. J. JOHNSTON COMPANY.
253 BROADWAY.
—
1898.

Copyright, 1889, 1892, 1894, 1898
BY
THE W. J. JOHNSTON COMPANY

Appendix B.
Copyright, 1898
BY
EDWIN J. HOUSTON

Printed by
Braunworth, Munn & Barber,
Brooklyn, N. Y., U. S. A.

PREFACE TO THE FIRST EDITION.

THE rapid growth of electrical science, and the almost daily addition to it of new words, terms and phrases, coined, as they too frequently are, in ignorance of those already existing, have led to the production of an electrical vocabulary that is already bewildering in its extent. This multiplicity of words is extremely discouraging to the student, and acts as a serious obstacle to a general dissemination of electrical knowledge, for the following reasons :

1. Because, in general, these new terms are not to be found even in the unabridged editions of dictionaries.
2. The books or magazines, in which they were first proposed, are either inaccessible to the ordinary reader, or, if accessible, are often written in phraseology unintelligible except to the expert.
3. The same terms are used by different writers in conflicting senses.
4. The same terms are used with entirely different meanings.
5. Nearly all the explanations in the technical dictionaries are extremely brief as regards the words, terms and phrases of the rapidly growing and comparatively new science of electricity.

In this era of extended newspaper and periodical publication, new words are often coined, although others, already in existence, are far better suited to express the same ideas. The new terms are used for a while and then abandoned ; or, if retained, having been imperfectly defined, their exact meaning is capable of no little ambiguity; and, subsequently, they are often unfortunately adopted by different writers with such varying shades of meaning, that it is difficult to understand their true and exact significance.

Then again, old terms buried away many decades ago and long since forgotten, are dug up and presented in such new garb that their creators would most certainly fail to recognize them.

It has been with a hope of removing these difficulties to some extent that the author has ventured to present this Dictionary of Electrical Words, Terms and Phrases to his brother electricians and the public generally.

He trusts that this dictionary will be of use to electricians, not only by showing the wonderful extent and richness of the vocabulary of the science, but also by giving the general consensus of opinion as to the significance of its different words, terms or phrases. It is, however, to the general public, to whom it is not only a matter of interest but also one of necessity to fully understand the exact meaning of electrical literature, that the author believes the book will be of the greatest value.

In order to leave no doubt concerning the precise meaning of the words, terms and phrases thus defined, the following plan has been adopted of giving :

- (1.) A concise definition of the word, term or phrase.
- (2.) A brief statement of the principles of the science involved in the definition.

(3) Where possible and advisable, a cut of the apparatus described or employed in connection with the word, term or phrase defined.

It will be noticed that the second item of the plan makes the Dictionary approach to some extent the nature of an Encyclopedia. It differs, however, from an Encyclopedia in its scope, as well as in the fact that its definitions in all cases are concise.

Considerable labor has been expended in the collection of the vocabulary, for which purpose electrical literature generally has been explored. In the alphabetical arrangement of the terms and phrases defined, much perplexity has arisen as to the proper catch-word under which to place them. It is believed that part of the difficulty in this respect has been avoided by the free use of cross references.

In elucidating the exact meaning of terms by a brief statement of the principles of the science involved therein, the author has freely referred to standard textbooks on electricity, and to periodical literature generally. He is especially indebted to works or treatises by the following authors, viz. : S. P. Thompson, Larden, Cumming, Hering, Prescott, Ayrton, Ayrton and Perry, Pope, Lockwood, Sir William Thomson, Fleming, Martin and Wetzler, Preece, Preece and Sivewright, Forbes, Maxwell, De Watteville, J. T. Sprague, Culley, Mascart and Joubert, Schwendler, Fontaine, Noad, Smee, Depretz, De la Rive, Harris, Franklin, Cavallo, Grove, Hare, Daniell, Faraday and very many others.

The author offers his Dictionary to his fellow electricians as a starting point only. He does not doubt that his book will be found to contain many inaccuracies, ambiguous statements, and possibly doubtful definitions. Pioneer work of this character must, almost of necessity, be marked by incompleteness. He, therefore, invites the friendly criticisms of electricians generally, as to errors of omission and commission, hoping in this way to be able finally to crystallize a complete vocabulary of electrical words, terms and phrases.

The author desires in conclusion to acknowledge his indebtedness to his friends, Mr. Carl Hering, Mr. Joseph Wetzler and Mr. T. C. Martin, for critical examination of the proof sheets; to Dr. G. G. Faught for examination of the proofs of the parts relating to the medical applications of electricity, and to Mr. C. E. Stump for valuable aid in the illustration of the book; also to Mr. George D. Fowle, Engineer of Signals of the Pennsylvania Railroad Company, for information concerning their System of Block Signaling, and to many others.

EDWIN J. HOUSTON.

CENTRAL HIGH SCHOOL, PHILADELPHIA, PA.,
SEPTEMBER, 1889.

PREFACE TO THE SECOND EDITION.

THE first edition of the "Dictionary of Electrical Words, Terms and Phrases" met with so favorable a reception that the entire issue was soon exhausted. Although but a comparatively short time has elapsed since its publication, electrical progress has been so marked, and so many new words, terms and phrases have been introduced into the electrical nomenclature, that the preparation of a new edition has been determined on rather than a mere reprint from the old plates.

The wonderful growth of electrical science may be judged from the fact that the present work contains more than double the matter and about twice the number of definitions that appeared in the earlier work. Although some of this increase has been due to words which should have been in the first edition, yet in greater part it has resulted from an actual multiplication of the words used in electrical literature.

To a certain extent this increase has been warranted either by new applications of electricity or by the discovery of new principles of the science. In some cases, however, new words, terms or phrases have been introduced notwithstanding the fact that other words, terms or phrases were already in general use to express the same ideas.

The character of the work is necessarily encyclopedic. The definitions are given in the most concise language. In order, however, to render these definitions intelligible, considerable explanatory matter has been added.

The Dictionary has been practically rewritten, and is now, in reality, a new book based on the general lines of the old book, but considerably changed as to order of arrangement and, to some extent, as to method of treatment.

As expressed in its preface, the author appreciates the fact that the earlier book was tentative and incomplete. Though the wide scope of the second edition, the vast number of details included therein, and the continued growth of the electrical vocabulary must also necessarily make this edition incomplete, yet the author ventures to hope that it is less incomplete than the first edition. He again asks kindly criticisms to aid him in making any subsequent edition more nearly what a dictionary of so important a science should be.

The order of arrangement in the first edition has been considerably changed. The initial letter under which the term or phrase is defined is in all cases that of the noun. For example, "Electric Light" is defined under the term "Light, Electric — —"; "Diameter of Commutation" under "Commutation, Diameter of — —," "Alternating Current Dynamo-Electric Machine" under "Machine, Dynamo-Electric, Alternating Current — —." As before, the book has numerous cross references.

Although the arrangement of the words, terms and phrases under the initial letter of the first word, term or phrase, as, for example, "Electric Light" under the letter E, might possess some advantages, yet, in the opinion of the author, the educational value

of the work would be thereby considerably decreased, since to a great extent such an arrangement would bring together incongruous portions of the science.

Frequent cross references render it possible to use the Dictionary as a text-book in connection with lectures in colleges and universities. With such a book the student need make notes only of the words, terms or phrases used, and afterwards, by the use of the definitions and explanatory matter connected therewith, work up the general subject matter of the lecture. The author has successfully used this method in his teaching.

In order to separate the definitions from the descriptive matter, two sizes of type have been used, the definitions being placed in the larger sized type.

In the descriptive matter the author has not hesitated to quote freely from standard electrical works, electrical magazines, and periodical literature generally. Among the numerous works consulted, besides those to which reference has already been made in the preface to the first edition, he desires to acknowledge his indebtedness especially to "The Alternating Current Transformer," by J. A. Fleming; to various works of John W. Urquhart; to "Modern Views of Electricity," by Prof. O. J. Lodge; to "A Text-book of Human Physiology," by Landois & Sterling; and to "Practical Application of Electricity in Medicine and Surgery," by Liebig & Rohe.

The cuts or diagrams used in the book have either been drawn especially for the work or have been taken from standard electrical publications.

The chart of standard electrical symbols and diagrams has been taken from Prof. F. B. Crocker's paper on that subject.

The definition of terms used in systems of electric railways have been taken mainly from a paper on "Standards in Electric Railway Practice," by O. T. Crosby.

The author desires especially to express his obligations to Prof. F. B. Crocker of the Electrical Engineering Department, Columbia College, New York, and to Carl Hering, of Philadelphia, for critical examination of the entire manuscript and for many valuable suggestions; also to *The Electrical World* and the *Electrical Engineer* of New York, and to Prof. Elihu Thomson, Edward Caldwell, T. C. Martin, Dr. Louis Bell, Joseph Wetzler, Nikola Tesla, Wm. H. Wahl, Prof. Wm. D. Marks, Prof. A. E. Dolbear, C. W. Pike, John Hoskin, and numerous others, for aid in connection with new words or phrases. So far as they relate to the medical applications of electricity, the proof sheets were revised by Dr. G. G. Faught, of Philadelphia.

The author desires to thank critics of the first edition and the electrical fraternity in general for valuable suggestions. He presents this second edition of his Dictionary in the hope that it may to some extent properly represent the vocabulary of electrical science.

CENTRAL HIGH SCHOOL,
PHILADELPHIA, May, 1892.

EDWIN J. HOUSTON.

PREFACE TO THE THIRD EDITION.

THE second edition of the "Dictionary of Electrical Words, Terms, and Phrases" was exhausted in such a comparatively short time that the publishers believed that what new matter might be required for a third edition could best be added in the form of an appendix.

Although not quite two years have elapsed since the issue of the second edition, yet the growth of electrical science has continued at so rapid a pace, and new words, terms, and phrases have of necessity been introduced so rapidly, that fully twenty per cent., both of new words and new matter, have been found necessary for the third edition. Had this fact been known in time, it might have been better to have developed the additional matter throughout the text, rather than placing it at the end of the book as an appendix.

Should a demand be made for a fourth edition, the author contemplates re-writing and re-arranging the entire volume. He is thoroughly aware of the inaccuracies and incompleteness of many of the definitions in the second edition, and hopes, in the event of a demand for a fourth edition, to produce a volume more nearly approximating to what an electrical dictionary should be. In the meantime, he again asks the kindly criticisms of his fellow laborers in the electrical field to aid him in the work.

In order to facilitate the use of the cross-references, all words, terms, and phrases referred to in the appendix are so marked; *i. e.*, (See Appendix—*Insulation, Kilo-metric, of Cable.*) All references not so marked will be found in the main text of the dictionary.

The author desires to express his obligations to numerous authors and technical journals for information as to new words, terms, and phrases, and to the significance generally given to them in actual use. He desires especially to acknowledge his obligations to his colleague, Mr. A. E. Kennelly, and to Professors R. A. Fessenden, C. Wellman Park; to Messrs. C. P. Steinmetz, J. F. Kelly, O. B. Shallenberger, Carl Hering, H. W. Frye, W. D. Weaver, W. F. C. Hasson, Townsend Wolcott, J. B. Cahoon, and many others, for reading of proof sheets and suggestions.

The author presents this third edition of the Dictionary with the hope that it may prove of value to the electrical fraternity.

EDWIN J. HOUSTON.

PHILADELPHIA, May, 1894.

PREFACE TO THE FOURTH EDITION.

IN preparing the fourth edition of his "Dictionary of Electrical Words, Terms and Phrases," the author soon found that the recent marvellous growth in the electrical vocabulary was such that it would be impossible to add, in the shape of a separate appendix, the new words, terms and phrases only, that it was necessary to introduce into the book. This will be evident from the fact that the added words exceed in number those already contained in the first, second and third editions. Since it was deemed inadvisable by the publisher to recast the entire book, the only course left open to the author was to alphabetically arrange all the old and new words, and to present them in concise definitions without any encyclopædic matter, referring the reader to the matter contained in the earlier editions for illustration and detail.

It has also been thought advisable to introduce a change in the manner of arrangement, the words, terms and phrases being alphabetically arranged according, either to the word, or to the first word of the term or phrase. This has permitted the entire suppression of all cross references, which, in view of the author's past experience, he believes will prove an advantage.

The author desires to acknowledge the very valuable assistance afforded him by his colleague, Dr. A. E. Kennelly, in the preparation of the matter for the fourth edition, both in collecting new terms, as well as in preparing the definitions, and reading the proof.

The author trusts, that the fourth edition of his electrical Dictionary will prove of benefit not only to the electrical world but to the reading public generally.

All criticisms will be gladly received.

EDWIN J. HOUSTON.

PHILADELPHIA, December, 1897.

A DICTIONARY

OF

ELECTRICAL

WORDS, TERMS AND PHRASES.

A

A. or An.—An abbreviation sometimes used in medical electricity for anode. (See *Anode*.)

A. C. C.—An abbreviation used in medical electricity for Anodic Closure Contraction. (See *Contraction, Anodic Closure*.)

A. D. C.—An abbreviation used in medical electricity for Anodic Duration Contraction. (See *Contraction, Anodic Duration*.)

A. O. C.—An abbreviation used in medical electricity for Anodic Opening Contraction. (See *Contraction, Anodic Opening*.)

Abscissa of Rectilinear Co-ordinates.—A line or distance cut off along axis of abscissas.

The abscissa of the point D, Fig. 1, on the curve O D R, is the distance D I, or its equal A 2, measured or cut off on the line A C, the axis of abscissas; or, briefly, A 2, is the abscissa of the point D.

Abscissas, Axis of — —One of the axes of co-ordinates used for determining the position of points on a curved line.

Thus the position of the point D, Fig. 1, on the curved line O D R, is determined by the perpendicular distances, D I and D 2, of such point from two straight lines, A B and A C, called the *axes of co-ordinates*. A C, is called the *axis of ab-*

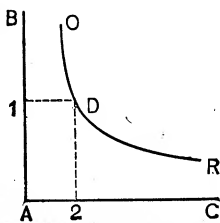

Fig. 1. Axes of Co-ordinates.

scissas, and A B, the *axis of ordinates*. The point

A, where the lines are considered as starting or originating, is called the *point of origin*, or, generally, the *origin*.

The use of co-ordinates was first introduced by the famous mathematician, Des Cartes.

Absolute.—Complete in itself.

The terms absolute and relative are used in electricity in the same sense as ordinarily.

Thus, a galvanometer is said to be calibrated *absolutely* when the exact current strengths required to produce given deflections are known; or, in other words, when the *absolute* current strengths are known; it is said to be calibrated *relatively* when only the *relative* current strengths required to produce given deflections are known.

The word absolute, as applied to the units employed in electrical measurements, was introduced by Gauss to indicate the fact that the values of such units are independent both of the size of the instrument employed and of the value of gravity at the particular place where the instrument is used.

The word absolute is also used with reference to the fact that the values of the units could readily be redetermined from well known constants, in case of the loss of the standards.

The *absolute units of length, mass, and time* are more properly called the C. G. S. units, or the *centimetre-gramme-second units*. (See *Units, Absolute*.)

An absolute system of units based on the *milligramme, millimetre, and second*, was proposed by Weber, and was called the *millimetre milligramme-second units*. It has been replaced by

the C. G. S. units. (See *Units, Centimetre-Gramme-Second. Units, Fundamental.*)

Absolute Block System for Railroads.—(See *Block System for Railroads, Absolute.*)

Absolute Calibration.—(See *Calibration, Absolute.*)

Absolute Electrometer.—(See *Electrometer, Absolute.*)

Absolute Galvanometer.—(See *Galvanometer, Absolute.*)

Absolute Unit of Current.—(See *Current, Absolute Unit of.*)

Absolute Unit of Electromotive Force.—(See *Force, Electromotive, Absolute Unit of.*)

Absolute Unit of Inductance.—(See *Inductance, Absolute Unit of.*)

Absolute Unit of Resistance.—(See *Resistance, Absolute Unit of.*)

Absolute Unit of Self-Induction.—(See *Induction, Self, Absolute Unit of.*)

Absolute Units.—(See *Units, Absolute.*)

Absolute Vacuum.—(See *Vacuum, Absolute.*)

Absorption.—The taking, or, literally, drinking in, of one form of matter by another, such as a gas, vapor or liquid by a solid; or of the energy of sound, light, heat, or electricity by ordinary matter.

Absorption, Acoustic — —The taking in of the energy of sound waves produced by one sounding or vibrating body by another vibrating body.

Acoustic absorption may result in the dissipation of the absorbed energy, as heat, or in sympathetic vibrations. (See *Vibrations, Sympathetic.*)

Absorption, Electric — —The apparent soaking of an electric charge into the glass or other solid dielectric of a Leyden jar or condenser. (See *Condenser.*)

The capacity of a condenser varies with the time the condenser remains charged and with the time taken in charging. Some of the charge acts as if it *soaked into* the solid dielectric, and this is the cause of the *residual charge*. (See *Charge, Residual.*) Therefore, when the con-

denser is discharged, less electricity appears than was passed in; hence the term *electric absorption*.

Absorption, Luminous — —The absorption of the energy of light in its passage through bodies.

When sunlight falls on an opaque colored body, such for example as a red body, all the colors but the reds are absorbed. The reds are then thrown off and thus cause the color. In the same manner, when sunlight falls on a transparent colored body, such for example as red, all colors but the reds are absorbed, and the reds are transmitted.

When sunlight falls on a phosphorescent body, a part of the light is absorbed as heat; another part is absorbed by the molecules being set into motion sufficiently rapid to cause them to emit light or to become luminous.

A mass of glowing gas or vapor absorbs waves of light of the same length as those it itself emits. This is the cause of the dark lines of the solar spectrum, called the Fraunhofer lines.

The amount of light absorbed by the glass globe of an incandescent lamp, according to Urquhart, is as follows, viz.:

Clear glass	10 per cent.
Ground glass	35 “
Opalescent glass	50 “

Absorption, Selective — —The absorption of a particular or selected character of waves of sound, light, heat, or electricity.

Absorption, Thermal — —The absorption of heat energy in its passage through a body.

The phenomena of thermal absorption are similar to those of luminous absorption. A substance that is transparent to heat, or which allows heat waves to pass through without absorption, is called *diathermanous*, or *diathermanic*, or is said to be *transparent to heat*.

Absorptive Power.—(See *Power, Absorptive.*)

Acceleration.—The rate of change of velocity.

Acceleration is thus distinguished from velocity: velocity expresses in time the rate-of-change of position, as a velocity of three metres per second; acceleration expresses in time the rate-of-change of velocity, as an acceleration of one centimetre per second.

Since all matter is inert, and cannot change its

condition of rest or motion without the application of some force, acceleration is necessarily due to some force outside the matter itself. A force may therefore be measured by the acceleration it imparts to a given mass of matter.

Acceleration is *positive* when the velocity is *increasing*, and *negative* when it is *decreasing*.

Acceleration, Dimensions of — —The value of the acceleration expressed in terms of the length or of distance by the time. (See *Acceleration, Unit of*.)

Acceleration, Unit of — —That acceleration which will give to a body unit-velocity in unit-time; as, for example, one centimetre-per-second in one second.

Bodies falling freely in a vacuum, and approximately so in air, acquire an acceleration which in Paris or London, at the end of a second, amounts to about 981 centimetres per second, or nearly 32.2 ft. per second.

$$A = \frac{V}{T}, \text{ or, in other words,}$$

The acceleration equals the velocity divided by the time.

But, since velocity equals the Distance, or the Length traversed in a Unit of Time, $V = \frac{L}{T}$.

$$\text{Therefore, } A = \frac{V}{T} = \frac{\frac{L}{T}}{T} = \frac{L}{T^2}, \text{ or}$$

The acceleration equals the length, or the distance passed through, divided by the square of the time in seconds.

These formulæ represent the *Dimensions of Acceleration*.

Accumulated Electricity.—(See *Electricity, Accumulated*.)

Accumulating Electricity.—(See *Electricity, Accumulating*.)

Accumulation of Electricity.—(See *Electricity, Accumulation of*.)

Accumulator.—A word sometimes applied to any apparatus in which the strength of a current is increased by the motion past it of a conductor, the currents produced in which tend to strengthen and increase the current which causes the induction.

The word accumulator is sometimes applied to Sir Wm. Thomson's *Electric Current Accumulator*.

Current accumulators operate on the reaction principle of dynamo-electric machines. In this sense, therefore, a dynamo-electric machine is an accumulator. (See *Machine, Dynamo-Electric, Reaction Principle of*.)

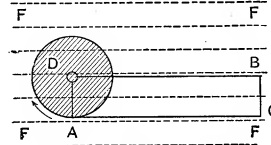

Fig. 2. Barlow's Wheel.

The copper disc D, Fig. 2, has freedom of rotation, on a horizontal axis at O, in a magnetic field, the lines of force of which, represented by the dotted lines in the drawing, pass downward perpendicularly into the plane of the paper.

If, now, a current from any source be passed in the direction A, O, B, C, A, through the circuit A, O, B, C, A, which is provided with spring contacts at O, and A, the disc will rotate in the direction of the curved arrow. This motion is due to the current acting on that part of the disc which lies between the two contacts—A and O. This apparatus is known as *Barlow's Wheel*.

If, when no current is passing through the circuit, the disc be turned in the direction of the arrow, a current is set up in such a direction as would oppose the rotation of the disc. (See *Law, Lenz's*.)

If, however, the disc be turned in the opposite direction to that of the arrow, induction currents will as before be produced in the circuit. As this rotation of the disc tends to move the circuit O A, towards the parallel but oppositely directed circuit B C, these two circuits being parallel and in opposite directions tend to repel one another, and there will thus be set up induced currents that tend to oppose the motion of rotation, and the current of the circuit will therefore increase in strength. (See *Dynamics, Electro*.) Should then a current be started in the circuit, and the original field be removed, the induction will be continued, and a current which, up to a certain extent, increases or accumulates, is maintained in the circuit during rotation of the disc. (*Larden*.)

Barlow's Wheel, when used in this manner, is known as *Thomson's Electric Current Accumulator*.

Accumulator.—A word often applied to a Leyden jar or condenser, which permits the gradual collection from an electric source of a greater charge than it would otherwise be capable of containing.

A condenser. (See *Condenser*.)

The ability of a source to accumulate an increased charge when connected to a condenser is due to the increased capacity which a plate or other conductor acquires when placed near another plate or conductor. (See *Condenser, Jar, Leyden*.)

Accumulator, Capacity of — —The capacity of a condenser, expressed in microfarads. (See *Condenser, Capacity of*.)

Accumulator or Condenser; Laws of Accumulation of Electricity.—Sir W. SNOW HARRIS, by the use of his Unit-Jar and Electric Thermometer, deduced the following laws for the accumulation of electricity, which we quote from Noad's "Student's Text-Book of Electricity," revised by Preece :

(1.) "Equal quantities of electricity are given off at each revolution of the plate of an electrical machine to an *uncharged surface*, or to a surface *charged* to any degree of saturation."

(2.) "A coated surface receives equal quantities of electricity in equal times ; and the number of revolutions of the plate is a fair measure of the relative quantities of electricity, all other things remaining the same."

(3.) "The free action of an electrical accumulation is estimated by the interval it can break through, and is directly proportional to the quantity of electricity."

(4.) "The free action is inversely proportional to the surface."

(5.) "When the electricity and the surface are increased in the same ratio, the discharging interval remains the same ; but if, as the electricity is increased, the surface is diminished, the discharging interval is directly as the square of the quantity of electricity."

(6.) "The resistance of air to discharge is as the square of the density directly."

According to some later investigations, the quantity a plane surface can receive under a given density depends on the linear boundary of the surface as well as on the area of the surface.

"The amount of electrical charge depends on

surface and linear extension conjointly. There exists in every plane surface what may be termed an *electrical boundary*, having an important relation to the grouping or disposition of the electric particles in regard to each other and to surrounding matter. This boundary in circles or globes is represented by their circumferences. In plane rectangular surfaces, it is by their linear extension or perimeter. If this *boundary* be constant, their electrical charge varies with the *square root of the surface*. If the *surface* be constant the charge varies with the *square root of the boundary*. If the surface and boundary both vary, the charge varies with the *square root of the surface multiplied into the square root of the boundary*."

These laws apply especially to continuous surfaces taken as a whole, and not to surfaces divided into separate parts.

By electrical charge HARRIS meant the quantity sustained on a given surface under a given electrometer indication ; by electrical intensity, he meant the indication of the electrometer corresponding to a given quantity on a given surface.

(See *Condenser, Capacity of, Capacity, Electrostatic, Capacity, Specific Inductive*.)

Accumulators of this character are now generally called Condensers. (For more modern principles concerning their construction and capacity see *Condenser, Condenser, Capacity of*.)

Accumulator, Secondary or Storage Cell — —Two inert plates partially surrounded by a fluid incapable of acting chemically on either of them until after the passage of an electric current, when they become capable of furnishing an independent electric current.

This use of the term accumulator is the one most commonly employed. A better term for such a cell is a secondary or storage cell. (See *Cell, Secondary or Storage*.)

Commercially, an accumulator consists of a single jar and its electrolyte, in which a single set of positive and negative plates is properly placed.

Accumulator, Water-Dropping — — An apparatus devised by Sir W. THOMSON for increasing the difference of potential between two electric charges.

The tube X Y, Fig. 3, connects with a reservoir of water which is maintained at the zero potential of the earth. The water escapes from

the openings at C and D, in small drops and falls on funnels provided, as shown, to receive the separate drops and again discharge them.

The vessels A, A', and B, B', which are electrically connected as shown, are maintained at a certain small difference of potential, as indicated by the respective + and - signs.

Under these circumstances, therefore, C and D, will be charged inductively with charges opposite to those of A and B, or with - and + electricities respectively. As the drops of water fall on the funnels, the charges which the funnels thus constantly receive are given up to B' and A', before the water escapes. Since, therefore, B, B', and A, A', are receiving constant charges, the difference of potential between them must continually increase. This apparatus operates on the same principle as the replenisher. The drops of water act as the carriers, and A, A', and B, B', as the hollow vessels. (See *Replenisher*.)

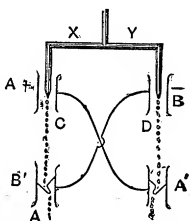

Fig. 3. Water-Dropping Accumulator.

Achromatic.—Free from false coloration.

Images formed by ordinary lenses do not possess the true colors of the object, unless the edges of the lenses are cut off by the use of a diaphragm; *i. e.*, an opaque plate with a central circular opening. The edges of the lenses disperse the light like an ordinary prism, and so produce rainbow colored (prismatic) fringes in the image. The use of an achromatic lens is to obviate this false coloration.

Achromatizable.—Capable of being freed from false coloration.

Achromatize.—To free from false coloration.

Achromatizing.—Freeing from false coloration.

Acid, Spent — —A battery acid, or other acid, that has become too weak for efficient action.

In a voltaic cell the acid of the electrolyte becomes spent by combining with the metal of the positive plate.

Acidometer.—A special form of hydrometer used in determining the specific gravity of the acid liquid in a secondary or storage

cell. (See *Areometer or Hydrometer. Cell, Storage*.)

The scale on the acidometer tube is made to indicate the density according to the distance the floating instrument sinks in the liquid.

Aclinic Line.—(See *Line, Aclinic*.)

Acoustic Absorption.—(See *Absorption, Acoustic*.)

Acoustic Engraving.—(See *Engraving, Acoustic*.)

Acoustic Telegraphy.—(See *Telegraphy, Acoustic*.)

Acoustic Tetanus.—(See *Tetanus, Acoustic*.)

Acoutemeter, Electric — —An apparatus for electrically testing the delicacy of hearing.

The Acoutemeter is one of the many applications of Hughes' sonometer. It consists of three flat coils placed parallel to one another on a graduated rod, passing through their axes. The central coil, which is used as the primary of an induction coil, is fixed. The other two, which are employed as secondary coils, are movable. (See *Sonometer, Hughes'. Coil, Induction. Microphone*.) A microphone, electrical tuning fork, switches, plugs, and other accessories, are suitably placed and connected. The subject whose hearing is to be tested is placed with his back to the apparatus, and with two telephone receivers tightly fixed to his ears. As various sounds are produced, the outer or movable coils are moved gradually away from the central coil, until no sound is heard in the telephone receivers. This distance is in the inverse ratio of the delicacy of hearing of the individual.

Actinic Photometer.—(See *Photometer, Actinic*.)

Actinic Ray.—(See *Ray, Actinic*.)

Actinism.—The chemical effects of light, as manifested by the decomposition of various substances.

Under the influence of the sun's light, the carbonic acid absorbed by the leaves of plants is decomposed in the living leaves into carbon, which is retained by the plant for the formation of its woody fibre or ligneous tissue, and oxygen, which is thrown off.

The bleaching of curtains, carpets, and other fabrics exposed to sunlight is caused by the actinic power of the light. The photographic picture is impressed by the actinic power of light on a plate covered with some sensitive metallic salt.

Actinograph.—An apparatus for measuring and recording the intensity of the chemical effects of light.

Actinography.—The method of measuring and recording the intensity of the chemical effects of light.

Actinometer.—A word sometimes applied to a pyrheliometer. (See *Pyrheliometer*.)

Actinometer, Electric — —An apparatus for electrically measuring the intensity of the chemically active rays present in any luminous radiation.

The rays from the luminous source are permitted to fall on a selenium resistance, and their intensity determined by the change observed in the resistance as indicated by the deflections of a galvanometer placed in circuit with the selenium resistance. Or, a thermo-electric pile is employed, and the amount of heat present determined by the indications of a galvanometer placed in its circuit.

Action, Cataphoric — —The action of electric osmose or cataphoresis. (See *Cataphoresis*.)

Action Currents.—(See *Currents, Action*.)

Action, Inductive, Lines of — — Lines within the space, separating a charge and a neighboring body, along which electrostatic inductive action takes place.

Lines of electrostatic force.

Lines of inductive action pass through the dielectric, separating the two bodies, and terminate on the surfaces of the conductor. According to the now generally received notions, the electrostatic charge exists in the mass of the dielectric, and not in that of the conductor. The lines of inductive action terminate against the surfaces, one at the positive, and the other at the negative surface. A true E. M. F. exists in the space traversed by lines of inductive action. A conductor brought into this space becomes electrified, or is strained in such a manner that a momentary current is produced by the rearrange-

ment of the electrification brought about by electrostatic induction.

Action, Local, of Dynamo-Electric Machine — —The loss of energy in a dynamo-electric machine by the setting up of eddy currents in its pole pieces, cores, or other conducting masses. (See *Currents, Eddy*.)

In a dynamo-electric machine local action is obviated by a *lamination of the pole pieces, armature core, etc.* (See *Core, Lamination of*.)

Action, Local, of Voltaic Cell — — An irregular dissolving or consumption of the zinc or positive element of a voltaic battery, by the fluid or electrolyte, when the circuit is open or broken, as well as when closed, or in regular action.

Local action is due to small particles of such impurities as carbon, iron, arsenic, or other negative elements, in the positive plate. These impurities form with the positive element minute voltaic couples, and thus direct the corrosive action of the liquid to portions of the plate near them. Local action causes a waste of energy. It may be avoided by the amalgamation of the zinc. (See *Zinc, Amalgamation of*.)

Action, Magne-Crystalline — —A term proposed by Faraday to express differences in the action of magnetism on crystalline bodies in different directions.

A needle of tourmaline, if hung with its axis horizontal, is no longer paramagnetic, as usual, but diamagnetic. The same is true of a crystal of bismuth. Faraday concluded from these experiments that a force existed distinct from either the paramagnetic or the diamagnetic force. He called this the *magne-crystalline force*.

Plücker infers from these phenomena that a definite relation exists between the *ultimate form of the particles of matter and their magnetic behavior*. The subject may be regarded as yet somewhat obscure. (See *Polarity, Diamagnetic*.)

Action of a Current on a Magnetic Pole. —(See *Current, Action of, on a Magnetic Pole*.)

Action, Refreshing, of Current — — The restoration, after fatigue, of muscular and nervous excitability obtained by the action of

voltaic alternatives. (See *Alternatives, Voltaic*.)

Activity.—The work done per second by any agent. (This term is but seldom used.)

Work-per-second, or, as generally termed in the United States, Power, or Rate of Doing Work. (See *Power*.)

Activity, Unit of — —A rate of working that will perform one unit of work per second.

In C. G. S. units, the activity of one erg per second.

The C. G. S. unit of activity is very small. One *Watt*, the practical unit of activity or power, is equal to ten million ergs per second. (See *Watt*.)

The unit of activity generally used for mechanical power is the horse-power, or 746 watts. (See *Horse-Power*.)

Actual Caution.—(See *Caution, Actual*.)

Acute Angle.—(See *Angle, Acute*.)

Adapter.—A screw nozzle fitted to an electric lamp, provided with a screw thread to enable it to be readily placed on a gas bracket or chandelier in place of an ordinary gas burner.

Adherence.—The quality or property of adhering. (See *Adhesion*.)

Adherence, Magnetic — —Adhesion between surfaces due to magnetic attraction.

Magnetic adhesion has been applied, among other things, to a brake action on car wheels, either by causing them to adhere directly to the track or to a brake-block.

Adhesion.—The mutual attraction which exists between unlike molecules. (See *Attraction, Molecular*.)

The phenomena of adhesion are due to the mutual attraction of dissimilar molecules.

Adhesion, Electric — —Adhesion between surfaces due to the attraction of unlike electrostatic charges.

Molecular adhesion must be distinguished from the attraction which causes a piece of dry and warmed writing paper, that has been rubbed by a piece of india-rubber, to stick to a papered wall. In this latter case the attraction between the wall

and the paper is due to the mutual attraction of two dissimilar electrostatic charges. Molecular adhesion must also be distinguished from the attraction of opposite magnetic poles.

Adhesion, Galvanoplastic — —The adhesion of a galvanoplastic deposit or coating to surfaces subjected to electroplating. (See *Plating, Electro*.)

Adiathermancy.—Opacity to heat.

A substance is said to be *diathermanous* when it is transparent to heat. Clear, colorless crystals of rock salt are very transparent both to light and to heat. Rock salt, covered with a layer or deposit of lampblack or soot, is quite transparent to heat. An *adiathermanous* body is one which is opaque to heat.

Heat transparency varies not only with different substances, but also with the nature of the source from which the heat is derived. Thus, a substance may be opaque to heat from a non-luminous source, such as a vessel filled with boiling water, while it is comparatively transparent to heat from a luminous source, such as an incandescent solid or a voltaic arc.

A similar difference exists as regards transparency to light. A colorless glass will allow light of any color to pass through it. A blue glass will allow blue light to pass freely through it, but will completely prevent the passage of any red light; and so with other colors.

Adiathermanic.—Possessing the quality of *adiathermancy*. (See *Adiathermancy*.)

Adjustable Condenser.—(See *Condenser, Adjustable*.)

Adjuster, Cord — —A device for adjusting the length of a pendant cord.

Adjustment.—Such a regulation of any apparatus as will enable it to properly perform its functions.

Æpinus' Condenser.—(See *Condenser, Æpinus'*.)

Aerial Cable.—(See *Cable, Aerial*.)

Aerial Cable, Suspending Wire of — — (See *Wire, Suspending, of Aerial Cable*.)

Aerial Line.—(See *Line, Aerial*.)

Aerolites.—A name sometimes given to meteorites.

Meteorites are masses of solids which pass

through the upper portions only of the earth's atmosphere on their approach to the orbit of the earth, or which fall through the air on the earth's surface from the sky. They are luminous at night and are followed by a train of fire. The luminosity is due to heat produced by friction through the air. Meteors frequently burst from the sudden expansion of their outer portions.

Some meteorites are composed of nearly pure iron alloyed with nickel. The majority of them, however, are merely stones or oxidized substances. Their average velocity is about 26 miles a second.

Affinity, Chemical — —Atomic attraction.

The force which causes atoms to unite and form chemical molecules.

Atomic or chemical attraction generally results in a loss of the characteristic qualities or properties which distinguish one kind of matter from another. In this respect chemical affinity differs from *adhesion*, or the force which holds unlike molecules together. (See *Adhesion, Attraction, Molecular*.) If, for example, sulphur is mixed with lampblack, no matter how intimate the mixture, the separate particles, when examined by a magnifying glass, exhibit their peculiar color, lustre, etc. If, however, the sulphur is chemically united with the carbon, a colorless, transparent, mobile liquid, called carbon bisulphide, results, that possesses a disagreeable, penetrating odor.

Chemical affinity, or atomic combination, is influenced by a variety of causes, viz.:

(1.) *Cohesion*. Cohesion, by binding the molecules more firmly together, opposes their mutual atomic attraction.

A solid rod of iron will not readily burn in the flame of an ordinary lamp; but, if the cohesion be overcome by reducing the iron rod to filings, it burns with brilliant scintillations when dropped into the same flame. In this case the increase of surface and the increased temperature of the smaller particles also contribute to the result.

(2.) *Solution*. Solution, by giving the molecules greater freedom of motion, favors their chemical combination.

(3.) *Heat*. Heat sometimes favors atomic combination possibly by decreasing the cohesion, and, possibly, by altering the electrical relations of the atoms. If too great, heat may produce decomposition. There is for most substances a critical

temperature below which chemical combination will not take place. (See *Thermolysis*.)

(4.) *Light*. Decomposition, or the lessening of chemical affinity, through the agency of light, is called *Actinism*. Light also causes the direct combination of substances. A mixture of equal volumes of hydrogen and chlorine unites explosively when exposed to the action of full sunlight. (See *Actinism*.)

(5.) *Electricity*. An electric spark will cause an explosive combination of a mixture of oxygen and hydrogen. Electricity also produces chemical decomposition. (See *Electrolysis*.)

Helmholtz accounts for the electro-chemical attraction of oxygen for zinc by supposing that all substances possess a definite amount of attraction for electricity, and that the attraction of zinc in this respect exceeds that of copper and the other metals. He thus regards the zinc as attracting its electric charge rather than as attracting the oxygen. Since both zinc and copper are dyad metals, this view, as will be seen, is at variance with later views.

Chemical affinity may be caused by the opposite attractions of electrical charges naturally possessed by the atoms of matter. This would appear to be rendered probable by the law of electro-chemical equivalence. (See *Equivalence, Electro-Chemical, Law of, Electricity, Atom of*.)

After Currents.—(See *Currents, After*.)

Aging of Alcohol, Electric — —(See *Alcohol, Electric Aging of*.)

Agonal.—Pertaining to the agone. (See *Agone*.)

Agone.—A line connecting places on the earth's surface where the magnetic needle points to the true geographical north.

The line of no declination or variation of a magnetic needle. (See *Needle, Magnetic, Declination of*.)

As all the places on the earth where the magnetic needle points to the true north may be arranged on a few lines, it will be understood that the pointing of the magnetic needle to the true geographical north is the exception and not the rule. In many places, however, the deviation from the true geographical north is so small that the direction of the needle may be regarded as approximately due north.

Agonic.—Pertaining to the agone.

Air-Blast for Commutators.—An invention of Prof. Elihu Thomson to prevent the injurious action of destructive flashing at the commutator of a dynamo-electric machine.

A thin, forcible blast of air is delivered through suitable tubes at points on the three-part commutator cylinder of the Thomson-Houston dynamo, where the collecting brushes bear on its surface. The effect is to blow out the arc or prevent its formation and thus avoid its destructive action on the commutator segments. The use of the air-blast also permits the free application of oil, thus further avoiding wear.

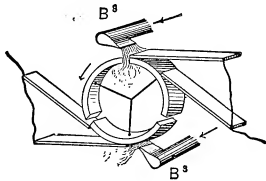

Fig. 4. Air-Blast on Commuta

The blast-nozzles are shown at B³, B³, Fig. 4, near the collecting brushes.

The air-supply is obtained from a blower attached directly to the shaft of the machine. Its construction and operation will be readily understood from an inspection of Fig. 5, in which the

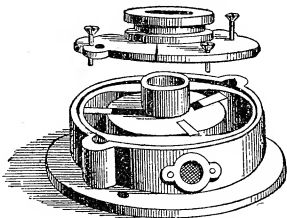

Fig. 5. The Thomson Blower.

top is removed for ready examination of the interior parts.

Air Churning.—(See *Churning, Air.*)

Air Condenser.—(See *Condenser, Air.*)

Air Field.—(See *Field, Air.*)

Air-Gap.—(See *Gap, Air.*)

Air-Line Wire.—(See *Wire, Air-Line.*)

Air Magnetic Circuit.—(See *Circuit, Air Magnetic.*)

Air-Pump.—(See *Pump, Air.*)

Air-Pump, Geissler's Mercurial — — (See *Pump, Air, Geissler's Mercurial.*)

Air-Pump, Mechanical — — (See *Pump, Air, Mechanical.*)

Air-Pump, Mercurial — — (See *Pump, Air, Mercurial.*)

Air-Pump, Sprengel's Mercurial — — (See *Pump, Air, Sprengel's Mercurial.*)

Air-Space Cut-Out.—(See *Cut-Out, Air-Space.*)

Alarm, Burglar — — A device, generally electric, for automatically announcing the opening of a door, window, closet, drawer, or safe, or the passage of a person through a hallway, or on a stairway.

Electric burglar-alarm devices generally consist of mechanism for the operation of an automatic make-and-break bell on the opening or closing of an electric circuit. The bell may either continue ringing only while the contact remains closed, or, may, by the throwing on of a local circuit or battery, continue ringing until stopped by some non-automatic device, such as a hand-switch.

The alarm-bell is stationed either in the house when occupied, or on the outside when the house is temporarily vacated, or may connect directly with the nearest police station.

Burglar-alarm apparatus is of a variety of forms. Generally, devices are provided by means of which, in case of house protection, an *annunciator* shows the exact part where an entrance has been attempted. (See *Annunciator, Burglar-Alarm.*) Switches are provided for disconnecting all or parts of the house from the alarm when so desired, as well as to permit windows to be partly raised for purposes of ventilation without sounding the alarm. A clock is frequently connected with the alarm for the purpose of automatically disconnecting any portion of the house at or for certain intervals of time.

Fig. 6 shows a burglar-alarm with annunciator, switches, switch-key, cut-off, and clock.

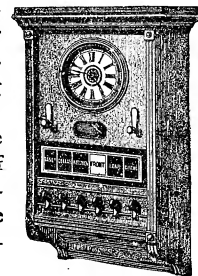

Fig. 6. Burglar-Alarm Annunciator.

Alarm, Burglar, Central-Station — — A burglar-alarm, the contact points of which are placed in the places to be protected, and

connected by suitable circuits with alarms placed in a centrally located station.

In a system of central-station burglar-alarms, a number of houses, factories, banks, etc., are all connected telegraphically with the nearest police station, or other central station, constantly provided with police officers. A series of contacts are placed on doors, windows, safes and money drawers, and connected with alarms and annunciators placed in the central station. An unauthorized entrance, therefore, is automatically telegraphed to the central station and its exact location indicated on the annunciator. Systems of central-station fire-alarms are constructed on a similar plan.

Alarm, Electric — — An automatic device by which attention is called to the occurrence of certain events, such as the opening of a door or window; the stepping of a person on a mat or staircase; the rise or fall of temperature beyond a given predetermined point; or, a device intended to call a person to a telegraphic or telephonic instrument.

Electric-alarms are operated by means of the ringing of an electro-magnetic or mechanical bell,

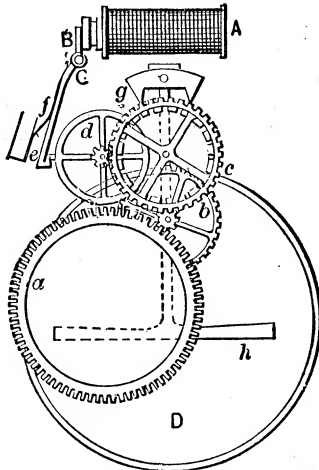

Fig. 7. *Electrically Started Mechanical Alarm.*

which is electrically called into action by either closing or opening an electric circuit, generally the former.

Electric-alarms may be divided into two classes, viz.:

- (1.) Mechanically operated alarms, or those in

which the alarm is given by clock-work, started by means of an electric current.

- (2.) Those in which the alarm is both set in action and operated by an electric current.

In Fig. 7 is shown the general construction of an electrically started mechanical alarm. The attraction of the armature B, by the electro-magnet A, moves the armature lever pivoted at C, and thus releases the catch e, and permits the spring or weight connected with the clock movement to set it in motion and strike the bell.

Electrically actuated alarm-bells are generally of the automatic make-and-break form. The striking lever is operated by the attraction of the armature of an electro-magnet, and is provided with a contact-point, so placed that when the hammer is drawn away from the bell, by the action of a spring, on the electro-magnet losing its magnetism, a contact is made, but when the hammer is drawn towards the bell the contact is opened. When, therefore, the hammer strikes the bell, the circuit is opened, and the electro-magnet releases its armature, permitting a spring to again close the contact by moving the striking lever away from the bell. Once set into action, these movements are repeated while there is battery power sufficient to energize the magnet.

In Fig. 8, in which is shown an electrically actuated alarm-bell, the battery terminals are con-

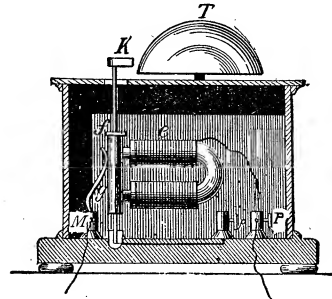

Fig. 8. *Automatic Make-and-Break.*

ected with the right and left hand binding-posts, P and M. The hammer, K, is connected with a striking lever, which forms part of the circuit, and which is attached to the armature of the electro-magnet e. A metallic spring, g, bears against the armature when the latter is away from the magnet, but does not touch the armature when it is moved towards the magnet. A small spring draws the lever away from the magnet when no current is passing. The movements of the arma-

ture thus automatically open and close the circuit of the electro-magnet.

This form of make-and-break is called an *automatic make-and-break*.

Alarm, Electrically Operated — — An alarm that is maintained in operation by the electric current. (See *Alarm, Electric*.)

Alarm, Electro-Mechanical — — A mechanically operated alarm that is started or set in operation by means of an electric current. (See *Alarm, Electric*.)

Alarm, Fire, Automatic — — An instrument for automatically telegraphing an alarm from any locality on its increase in temperature beyond a certain predetermined point.

Fire-alarms are operated by *thermostats*, or by means of *mercurial contacts*; *i. e.*, a contact closed by the expansion of a column of mercury. (See *Thermostat. Contact, Mercurial*.)

In systems of *fire-alarm telegraphs*, the alarm is automatically sounded in a central police station and in the district fire-engine house. (See *Telegraphy, Fire-Alarm*.)

Alarm, Mercurial Temperature — — An instrument for automatically telegraphing an alarm by means of a mercurial contact on a predetermined change of temperature.

The action of mercurial contacts is dependent on the fact that, as the mercury expands more than glass by the action of heat, the mercury level reaches a contact-point placed in a glass tube and thus completes the circuit through its own mass, which forms the other or movable contact. Sometimes both contacts are placed on opposite sides of a tube and are closed when the mercury reaches them.

Mercurial temperature or thermostat alarms are employed in hot-houses, incubators, tanks and buildings for the purpose of maintaining a uniform temperature.

Alarm, Telegraphic — — An alarm-bell for calling the attention of an operator to a telegraphic instrument when the latter is of the non-acoustic or needle type.

In acoustic systems of telegraphy the sounds themselves are generally sufficient.

Alarm, Telephonic — — An alarm-bell for calling a correspondent to the receiving telephone.

These alarms generally consist of magneto-electric bells. (See *Bell, Magneto-Electric*.)

Alarm, Temperature — — An electric alarm automatically operated on a change of temperature. (See *Alarm, Fire, Automatic*.)

Alarm, Thermostat — — An electric alarm that is thrown into action by a thermostat. (See *Thermostat*.)

Alarm, Water or Liquid Level — — A device for electrically sounding an alarm when a water surface varies materially from a given level.

An electric bell is placed in a circuit that is automatically closed or broken by the movement of contact-points operated by the change of liquid level.

A form of electric alarm for a water-level is shown in Fig. 9. The float is provided with contacts for closing an electric circuit, when it either rings a bell, or, by its action on some form of automatic cut-off, stops the water.

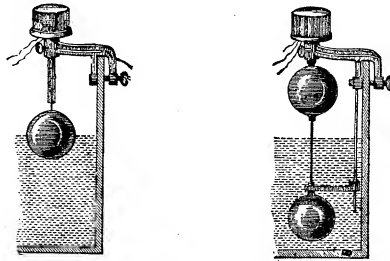

Fig. 9. Water-Level Alarm. Fig. 10.

When arranged with a double float, as shown in Fig. 10, the alarm may be made to signal either a too high or a too low water level.

Alarm, Yale-Lock-Switch Burglar — — An apparatus whereby the opening of a door by an authorized party provided with the regular key will not sound an alarm, but any other opening will sound such alarm.



Fig. 11. Yale-Lock-Switch.

A Yale-lock burglar-alarm switch is shown in Fig. 11.

Alcohol, Electric Aging of — — A process for the rapid aging of alcohol, by ex-

posing it to the action of electrically produced ozone.

Instead of the ordinary process of aging alcohol, by exposing it in partially closed vessels to the action of air, it is exposed to the action of ozone, electrically produced.

The ozone employed is obtained in substantially the usual way by the passage of a rapid succession of electric sparks through air.

Alcohol, Electric Rectification of — — A process whereby the bad taste and odor of alcohol, due to the presence of aldehydes, are removed by the electrical conversion of the aldehydes into true alcohols through the addition of hydrogen atoms.

An electric current sent through the liquid between zinc electrodes liberates oxygen and hydrogen from the decomposition of the water. The nascent or atomic hydrogen converts the aldehydes into alcohol and deprives the products of their fusel oil, while the oxygen forms insoluble zinc oxide.

Algebraic Co-efficient.—(See *Co-efficient, Algebraic.*)

Algebraic Notation.—(See *Notation, Algebraic.*)

All-Night Arc Lamp.—(See *Lamp, All-Night Arc.*)

All-Night Electric Lamp.—(See *Lamp, All-Night Arc.*)

Allotropic.—Pertaining to allotropy. (See *Allotropy.*)

Allotropic State.—(See *State, Allotropic.*)

Allotropy.—A variation of the physical properties of an elementary substance without change of composition of its molecules.—(See *State, Allotropic.*)

Alloy.—A combination, or mixture, of two or more metallic substances.

Alloys in most cases appear to be true chemical compounds: In a few instances, however, they may form simple mixtures.

The composition of a few important alloys is here given:

Solder, plumber's; Tin 66 parts, Lead 34 parts.
Pewter, hard; Tin 92 parts, Lead 8 parts.
Britannia metal; Tin 100 parts, Antimony 8 parts, Copper 4 parts, Bismuth, 1 part.

Type metal; Lead 80, Antimony 20 parts.
Brass, white; Copper 65, Zinc 35 parts.
Brass, red; Copper 90, Zinc 10 parts.
Speculum metal; Copper 67, Tin 33 parts.
Bell metal; Copper 78, Tin 22 parts.
Aluminium bronze; Copper 90, Aluminium 10 parts.

Alloy.—To form a combination or mixture of two or more metallic substances.

Alloy, German Silver — —An alloy employed for the wires of resistance coils, consisting of 50 parts of copper, 25 of zinc, and 25 of nickel.

German silver wire is suitable for resistance coils, because its resistance varies but slightly with changes of temperature. It is cheaper than *platinum-silver alloy*, and is therefore employed extensively. Platinum silver alloy, however, has more resistance for a given size of wire, and its resistance varies somewhat less than German silver with changes of temperature, and is therefore used where greater accuracy is desired.

Alloy, Palladium — —An alloy of palladium with other metals.

Palladium forms a number of useful alloys with various metals. Some of the palladium alloys are as elastic as steel, are unaffected by moisture or ordinary corrosive agencies, and are entirely devoid of paramagnetic properties; that is to say, they cannot be magnetized after the manner of iron.

These properties have been utilized by their discoverer, Paillard, in their employment for the hair-springs, escapements and balance wheels of watches, in order to permit the watches to be carried into strong magnetic fields without any appreciable effects on the rate of the watch. A number of careful tests made by the author, by long continued exposure of watches, thus protected by the Paillard alloys, in extraordinary fields, show that the protection thus given the watches enables them to be carried into the strongest possible magnetic fields without appreciably affecting their rate.

The Paillard palladium alloys have the following composition, viz.:

Alloy No. 1.

Palladium.....	60 to 75 parts.
Copper.....	15 to 25 “
Iron.....	1 to 5 “

Alloy No. 2.

Palladium.....	50 to 75	parts.
Copper.....	20 to 30	"
Iron.....	5 to 20	"

Alloy No. 3.

Palladium.....	65 to 75	"
Copper.....	15 to 25	"
Nickel.....	1 to 5	"
Gold.....	1 to 2½	"
Platinum.....	½ to 2	"
Silver.....	3 to 10	"
Steel.....	1 to 5	"

Alloy No. 4.

Palladium.....	45 to 50	"
Silver.....	20 to 25	"
Copper.....	15 to 25	"
Gold.....	2 to 5	"
Platinum.....	2 to 5	"
Nickel.....	2 to 5	"
Steel.....	2 to 5	"

The great value of the palladium alloys, when employed for the hair-springs of watches, arises not only from their non-magnetizable properties, and their inoxidizability, but particularly from the fact that their elasticity is approximately the same for comparatively wide ranges of temperature.

Alloy, Platinum-Silver — — An alloy consisting of one part of platinum, and two parts of silver.

Platinum-silver alloy is now extensively employed for resistance coils from the fact that changes in temperature of the alloy produce but comparatively small changes in its electrical resistance. (See *Alloy, German Silver.*)

Alphabet, Telegraphic — — An arbitrary code consisting of dots and dashes, sounds, deflections of a magnetic needle, flashes of light, or movements of levers, following one another in a given predetermined order, to represent the letters of the alphabet and the numerals.

Alphabet, Telegraphic: International Code — — The code of signals for letters, etc., employed in England and on the European continent generally.

Similar symbols are employed for the numerals and the punctuation marks.

It will be observed that it is mainly in the

characters of the American Morse, in which spaces are used, that the Continental characters differ from the American. This is due to the use of the needle instrument, with which a space cannot well be represented. A movement or deflection of the

	Single		Single
Printing	Needle	Printing	Needle
a . - -	/	n - - -	/ \
b - - - -	/ \ \	o - - - -	/ / /
c - - - -	/ \ /	p - - - -	/ \ / \
d - - -	/ \	q - - - -	/ \ / \ /
e .	/	r - - - -	/ \ / \
f - - - -	/ \ / \	s - - -	/ \ \
g - - - -	/ \ \	t - - -	/
h - - - -	/ \ \ \	u - - -	/ \
i - -	/ \	v - - - -	/ \ \ /
j - - - -	/ \ / \ /	w - - - -	/ \ / \ /
k - - -	/ \ /	x - - - -	/ \ \ / \
l - - - -	/ \ \ / \	y - - - -	/ \ \ / \ /
m - - -	/ \ /	z - - - -	/ \ \ / \ \

International Telegraphic Code.

needle to the left signifies a dot; a movement to the right, a dash.

Alphabet, Telegraphic: Morse's — — Various groupings of dots and dashes, or deflections of a magnetic needle to the right and left, which represent the letters of the alphabet or other signs.

In the Morse alphabet dots and dashes are employed in recording systems, and sounds of varying intervals, corresponding to the dots and dashes, in the sounder system.

A dash is equal in length of time to three dots. The space between the separate characters of a single letter is equal to one dot, except in the American Morse, in which the following letters contain longer spaces: C, O, R, Y, and Z. The lengthened spaces are equal to two dots. L is one and a half times the length of T.

The sound produced by the down stroke of the sounding lever in the Morse sounder is readily distinguishable from the up stroke. When these differences are taken in connection with the intervals between successive sounds there is no difficulty in reading by sound.

(For methods of receiving the alphabet, see *Sounder, Morse Telegraphic. Recorder, Morse. Recorder, Bain's Chemical. Recorder, Siphon. Relay. Magnet, Receiving.*) In the *needle telegraph*, the code is similar to that used in the Morse Alphabet. (See *Telegraphy, Single-Needle.*)

AMERICAN MORSE CODE.
ALPHABET.

a ---	n ---
b -----	o ----
c ----	p -----
d ----	q -----
e -	r - - -
f ----	s - - -
g -----	t ---
h -----	u ----
i - -	v -----
j -----	w -----
k -----	x -----
l -----	y - - -
m -----	z -----
	& - - -

NUMERALS.

1 -----	6 -----
2 -----	7 -----
3 -----	8 -----
4 -----	9 -----
5 -----	0 -----

PUNCTUATION MARKS.

Period -----	Interrogation -----
Comma -----	Exclamation -----

	Printing	Single Needle
1	-----	\\ / / /
2	-----	\\ / / /
3	-----	\\ / / /
4	-----	\\ / / /
5	-----	\\ / / /
6	-----	\\ / / /
7	-----	\\ / / /
8	-----	\\ / / /
9	-----	\\ / / /
10	-----	\\ / / /
Period	-----	\\ \\ \\
Comma	-----	\\ / / /
Interrogation	-----	\\ / / /
Exclamation	-----	\\ / / /
Colon	-----	\\ / / /
Semicolon	-----	\\ / / /

Alteration Theory of Muscle or Nerve Current.—(See *Theory, Alteration, of Muscle or Nerve Current.*)

Alternating Arc.—(See *Arc, Alternating.*)

Alternating Current Circuit.—(See *Circuit, Alternating Current.*)

Alternating Current Condenser.—(See *Condenser, Alternating Current.*)

Alternating Current Dynamo-Electric Machine.—(See *Machine, Dynamo-Electric, Alternating Current.*)

Alternating Current Electric Motor.—(See *Motor, Electric, Alternating Current.*)

Alternating Currents.—(See *Currents, Alternating.*)

Alternating Currents, Distribution of Electricity by — — (See *Electricity, Distribution of, by Alternating Currents.*)

Alternating Discharge.—(See *Discharge, Alternating.*)

Alternating Dynamo-Electric Machine.—(See *Machine, Dynamo-Electric, Alternating Current.*)

Alternating Electrostatic Field.—(See *Field, Alternating Electrostatic.*)

Alternating Electrostatic Potential.—(See *Potential, Alternating Electrostatic.*)

Alternating Field.—(See *Field, Alternating.*)

Alternating Influence Machine, Wimshurst's — — (See *Machine, Wimshurst's Alternating Influence.*)

Alternating Magnetic Field.—(See *Field, Alternating Magnetic.*)

Alternating Magnetic Potential.—(See *Potential, Alternating Magnetic.*)

Alternating Potential.—(See *Potential, Alternating.*)

Alternating Primary Currents.—(See *Currents, Alternating Primary.*)

Alternating Secondary Currents.—(See *Currents, Alternating Secondary.*)

Alternation.—A change in direction or phase.

Alternations.—Changes in the direction of a current in a circuit.

A current that changes its direction 300 times per second is said to possess 300 alternations per second.

Alternations, Complete — — A change in the direction of a current in a circuit from its

former direction and back again to that direction. A complete to-and-fro change.

Complete alternations are sometimes indicated by the symbol \sim .

Alternations, Frequency of — —A phrase employed to denote the number of alternations per second.

Alternative Path.—(See *Path, Alternative*.)

Alternatives, Voltaic — —A term used in medical electricity to indicate sudden reversals in the polarity of the electrodes of a voltaic battery.

An alternating current from a voltaic battery, obtained by the use of a suitable commutator.

Sudden reversals of polarity produce more energetic effects of muscular contraction than do simple closures or completions of the circuit.

The muscular contraction produced by a voltaic current is much stronger when the direction of the current is rapidly reversed by means of a commutator than when the current is more slowly broken and the poles then reversed.

The effect of voltaic alternatives is to produce quick contractions that are in strong contrast to the prolonged contractions that result from the faradic current. In the faradic machine, the reversals are so rapid that the muscle fails to return to rest before it is again contracted.

Voltaic alternatives are sometimes indicated by the contraction V. A.

Alternator.—A name commonly given to an alternate current dynamo. (See *Machine, Dynamo-Electric, Alternating Current*.)

Alternator, Compensated Excitation of — —An excitation of an alternating current dynamo-electric machine, in which the field is but partially excited by separate excitement, the remainder of its exciting current being derived from the commuted currents of a small transformer placed in the main circuit of the machine.

The object of compensated excitation of an alternator is to render the machine self-governing.

Amalgam.—A combination or mixture of a metal with mercury.

Amalgam, Electric — —A substance

with which the rubbers of the ordinary frictional electric machines are covered.

Electric amalgams are of various compositions. The following formula produces an excellent amalgam :

Melt together five parts of zinc and three of tin, and gradually pour the molten metal into nine parts of mercury. Shake the mixture until cold, and reduce to a powder in a warm mortar. Apply to the cushion by means of a thin layer of stiff grease.

Mosaic gold, or bisulphide of tin, and powdered graphite, both act as good electric amalgams.

An electric amalgam not only acts as a conductor to carry off the negative electricity, but, being highly negative to the glass, produces a far higher electrification than would mere leather or chamois.

Amalgamate.—To form into an amalgam.

Amalgamating.—Forming into an amalgam.

Amalgamation.—The act of forming into an amalgam, or effecting the combination of a metal with mercury.

Amalgamation of Zinc Plates of Voltaic Cell.—(See *Plates, Zinc, of Voltaic Cell, Amalgamation of*.)

Amber.—A resinous substance, generally of a transparent, yellow color.

Amber is interesting electrically as being believed to be the substance in which the properties of electric attractions and repulsions, imparted by friction or rubbing, were first noticed. It was called by the Greeks *ήλεκτρον*, from which the word electricity is derived. This property was mentioned by the Greek, Thales of Miletus, 600 B. C., as well as by Theophrastus.

American System of Telegraphy.—(See *Telegraphy, American System of*.)

American Twist-Joint.—(See *Joint, American Twist*.)

American Wire Gauge.—(See *Gauge, Wire, American*.)

Ammeter.—A form of galvanometer in which the value of the current is measured directly in ampères. (See *Galvanometer*.)

An ampère-meter or ammeter is a commercial form of galvanometer in which the deflections of

a magnetic needle are calibrated or valued in ampères. As a rule the coils of wire in an ammeter are of lower resistance than in a voltmeter. The magnetic needle is deflected from its zero position by the field produced by the current whose strength in ampères is to be measured. This needle is held in the zero position by the action of a magnetic field, either of a permanent or an electro-magnet, by the action of a spring, or by a weight under the influence of gravity. There thus exist a variety of ammeters, viz.: *permanent-magnet* ammeters, *electro-magnetic* ammeters, *spring* ammeters and *gravity* ammeters.

In the form originally devised by Ayrton and Perry, the needle came to rest almost immediately, or was *dead-beat* in action. (See *Damping*.) It moved through the field of a permanent magnet. The instrument was furnished with a number of coils of insulated wire, which could be connected either in *series* or in *multiple-arc* by means of a *commutator*, thus permitting the scale reading to be verified or calibrated by the use of a single voltaic cell. (See *Circuits, Varieties of Commutator. Calibration, Absolute. Calibration, Relative.*) In this case the coils were turned to series, and a plug pulled out, thus introducing a resistance of one ohm.

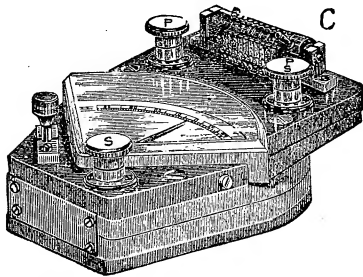

Fig. 12. Ayrton and Perry Ammeter.

Fig. 12 represents an ampère-meter devised by Ayrton and Perry. A device called a *commutator* for connecting the coils either in series or parallel is shown at C. Binding posts are provided at P, PS, and S. The dynamo terminals are connected at the posts P, PS, and the current will pass only when the coils are in multiple, thus avoiding accidental burning of the coils. In this case the entire current to be measured passes through the coils so coupled. The posts S and PS, are for connecting the single battery cell current.

A great variety of ampère-meters, or ammeters, have been devised. They are nearly all, how-

ever, constructed on essentially the same general principles.

Commercial ammeters are made in a great variety of forms. When the currents to be measured are large, as is generally the case in electric light or power stations, they consist of a coil of insulated wire, often of a single turn, or even of but a part of a turn, having a balanced core of iron or steel capable of moving freely within it.

Ammeter, Electro-Magnetic — —A form of ammeter in which a magnetic needle is moved against the field of an electro-magnet by the field of the current it is measuring. (See *Ammeter*.)

Ammeter, Gravity — —A form of ammeter in which a magnetic needle is moved against the force of gravity by the field of the current it is measuring. (See *Ammeter*.)

Ammeter, Magnetic-Vane — —An ammeter in which the strength of a magnetic field produced by the current that is to be measured is determined by the repulsion exerted between a fixed and a movable iron vane, placed in said field and magnetized thereby. (See *Voltmeter, Magnetic-Vane*.)

Ammeter, Permanent-Magnet — —A form of ammeter in which a magnetic needle is moved against the field of a permanent magnet by the field of the current it is measuring. (See *Ammeter*.)

Ammeter, Reducteur for — —(See *Reducteur, or Shunt for Ammeter*.)

Ammeter, Spring — —A form of ammeter in which a magnetic needle is moved against the action of a spring by the field of the current it is measuring. (See *Ammeter*.)

Amorphous.—Having no definite crystalline form.

Mineral substances have certain crystalline forms, that are as characteristic of them as are the forms of animals or plants. Under certain circumstances, however, they occur without definite crystalline form, and are then said to be amorphous solids.

Ampèrege.—The number of ampères passing in a given circuit.

The current strength in any circuit as indicated by an ampère-meter placed in the circuit.

Ampère.—The practical unit of electric current.

Such a rate-of-flow of electricity as transmits one coulomb per second.

Such a current (or rate-of-flow or transmission of electricity) as would pass with an electromotive force of one volt through a circuit whose resistance is equal to one ohm.

A current of such a strength as would deposit .005084 grain of copper per second.

A current of one ampère is a current of such definite strength that it would flow through a circuit of a certain resistance and with a certain electromotive force. (See *Force, Electromotive Volt, Resistance, Ohm.*)

Since the ohm is the practical unit of resistance, and the volt the practical unit of electromotive force, the ampère, or the practical unit of current, is the current that would flow through unit resistance, under unit pressure or electromotive force.

To make this clearer, take the analogy of water flowing through a pipe under the pressure of a column of water. That which causes the flow is the *pressure* or *head*; that which resists the flow is the *friction* of the water against the pipe, which will vary with a number of circumstances. The *rate-of-flow* may be represented by *so many cubic inches of water per second.*

As the pressure or head increases, the flow increases proportionally; as the resistance increases, the flow diminishes.

Electrically, electromotive force corresponds to the pressure or head of the water, and resistance to the friction of the water and the pipe. The ampère, which is the *unit rate-of-flow per second*, may therefore be represented as follows,

viz.: $C = \frac{E}{R}$, as was announced by Ohm in his law. (See *Law of Ohm.*)

This expression signifies that C, the *current* in *ampères*, is equal to E, the *electromotive force* in *volts*, divided by R, the *resistance* in *ohms*.

We measure the rate-of-flow of liquids as so many *cubic inches* or *cubic feet per second*—that is, in units of quantity. We measure the rate-of-flow of electricity as so much electricity per second. The electrical unit of quantity is called the *Coulomb*. (See *Coulomb.*) The coulomb is such a quantity as would pass in one second through a circuit in which the rate-of flow is one ampère.

An *ampère* is therefore equal to *one coulomb per second.*

The electro-magnetic unit of current is such a current that, passed through a conducting wire bent into a circle of the radius of one centimetre, would tend to move perpendicular to its plane a *unit magnetic pole* held at its centre, and sufficiently long to practically remove the other pole from its influence, with unit force, *i. e.*, the force of one *dyne*. (See *Dyne.*) The ampère, or practical electro-magnetic unit, is *one-tenth* of *such a current*; or, in other words, the *absolute unit of current* is ten ampères.

An ampère may also be defined by the chemical decomposition the current can effect as measured by the quantity of hydrogen liberated, or metal deposited.

Defined in this way, an ampère is such a current as will deposit .0011815 gramme, or .017253 grain, of silver per second on one of the plates of a silver *voltmeter*, from a solution of silver nitrate containing from 15 to 30 per cent. of the salt (See *Voltmeter*), or which will decompose .00009326 gramme, or .001439 grain of dilute sulphuric acid per second, or pure sulphuric acid at 59 degrees F. diluted with about 15 per cent. of water, that is, dilute sulphuric acid of Sp. Gr. of about 1.1. The present scientific and commercial practice is to take the ampère to be such a current as will deposit 4.024 grammes of silver in one hour.

Ampère Arc.—(See *Arc, Ampère.*)

Ampère-Foot.—(See *Feet, Ampère.*)

Ampère-Hour.—(See *Hour, Ampère.*)

Ampère-Meter.—An ammeter. (See *Ammeter.*)

Ampère-Meter, Balance or Neutral Wire
— —An ampère-meter placed in the circuit of the neutral wire, in the three-wire system of electric distribution, for the purpose of showing the excess of current passing over one side of the system as compared with the other side, when the central wire is no longer neutral.

Ampère-Minute.—(See *Minute, Ampère.*)

Ampère Ring.—(See *Ring, Ampère.*)

Ampère-Second.—(See *Second, Ampère.*)

Ampère Tap.—(See *Tap, Ampère.*)

Ampère-Turn.—(See *Turn, Ampère.*)

Ampère-Turn, Primary — —(See *Turn, Ampère, Primary.*)

Ampère-Turn, Secondary — —(See *Turn, Ampère, Secondary*.)

Ampère-Volt.—A watt, or the $\frac{1}{746}$ of a horse-power.

This term is generally written *volt-ampère*. (See *Volt-Ampère*.)

Ampère-Winding.—(See *Winding, Ampère*.)

Ampère's Rule for Effect of Current on Needle.—(See *Rule, Ampère's, for Effect of Current on Needle*.)

Ampère's Theory of Magnetism.—(See *Magnetism, Ampère's Theory of*.)

Ampèrian Currents.—(See *Currents, Ampèrian*.)

Amplitude of Vibration or Wave.—(See *Vibration or Wave, Amplitude of*.)

Ammunition-Hoist, Electric — —An electrically operated hoist for raising ammunition to the deck of a ship.

In the electric ammunition-hoist the electric motor which moves the hoist is made to follow the motions of the operator's hand, both, as regards direction and speed. The motion of a crank, or wheel, causes a switch to start an electric motor in a certain direction, which tends to close the switch, thus necessitating a race between the operator and the motor. Should the operator begin to close the switch more slowly, the motor will overtake him, will partially close the switch, and thus lower the speed of the motor.

Analogous Pole.—(See *Pole, Analogous*.)

Analysis.—The determination of the composition of a compound substance by separating it into the simple or elementary substances of which it is composed.

Analysis, Electric — —The determination of the composition of a substance by electrical means.

Various processes have been proposed for electric analysis; they consist essentially in decomposing the substance by means of electric currents, and are either qualitative or quantitative. (See *Electrolysis*.)

Analysis, Electrolytic — —A term sometimes used instead of electric analysis. (See *Analysis, Electric*.)

Analysis, Qualitative — —A chemical

analysis which merely ascertains the kinds of elementary substances present.

Analysis, Quantitative — —A chemical analysis which ascertains the relative proportions in which the different components enter into a compound.

Analyzable.—Separable into component parts.

Analyze.—To separate into component parts.

Analyze, Electrically — —To separate electrically into component parts.

Analyzer, Electric — —A gridiron of metallic wires which is transparent to electromagnetic waves, when its length is perpendicular to them, but opaque to them—*i. e.*, possessing the ability to reflect them—when rotated 90 degrees from its former position.

The electric analyzer, it will be observed, is analogous to an analyzer for polarized light. A reflecting surface, for example, being able to reflect polarized light in a given position, and unable to reflect it when rotated 90 degrees from such position, is capable of acting as an analyzer for polarized light.

Analyzer, Gray's, Harmonic Telegraphic — —An electro-magnet, the armature of which consists of a steel ribbon stretched in a metallic frame and capable through regulation, as to tension, by means of a screw, of being tuned to a certain note.

The steel ribbon is thrown into vibration whenever pulsations from the transmitting instruments are sent over the line corresponding to the rate of motion of the ribbon, but is not set into vibration by any others. If, therefore, a number of different analyzers, tuned to different notes, are placed on the same line, each will be operated only by the pulsations sent into the line corresponding to its rate of motion, and thus multiple transmission in the same direction is possible. In order to strengthen the tones of the analyzers, each is provided with a resonant air column. (See *Resonator, Telegraphy, Multiplex*.)

Analyzing.—Separating into component parts.

Anelectric.—A word formerly applied to bodies (conductors) which it was believed could not be electrified by friction.

This term is now obsolete. Conductors are easily electrified, when insulated.

Anelectrotonic State.—(See *State, Anelectrotonic.*)

Anelectrotonic Zone.—(See *Zone, Anelectrotonic.*)

Anelectrotonus.—In electro-therapeutics, the decreased functional activity which occurs in a nerve in the neighborhood of the anode, or positive electrode, when applied therapeutically. (See *Electrotonus.*)

Anemometer, Electric — —An apparatus to electrically record or indicate the direction and intensity of the wind.

In the electric recording anemometer, the force or velocity of the wind, or both, are recorded on a moving sheet of paper, on which the time is marked, so that the exact time of any given change is known.

Anemoscope.—An instrument which indicates, but does not measure the intensity or record the direction of the wind.

The word is often, though improperly, used interchangeably for anemometer.

Angle.—The deviation in direction between two lines or planes that meet.

Angles are measured by arcs of circles. The angle at B A C, Fig. 13, is the deviation of the straight line A B, from A C. In reading the lettering of an angle the letter placed in the middle indicates the angle referred to. Thus B A C, means the angle between A B and A C; B A D, the angle between B A and A D. Angles are valued in degrees, there being 360 degrees in an entire circumference or circle. Degrees are indicated thus: 90°, or ninety degrees.

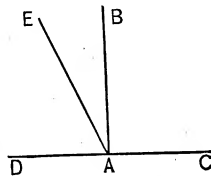

Fig. 13. Angles.

Angle, Acute — —An angle whose value is less than a right angle or 90 degrees.

B A E, or E A D, in Fig. 13, is an acute angle.

Angle, Complement of — —What an angle needs to make its value 90 degrees, or a right angle.

Thus in Fig. 13, B A E, is the complement of the angle E A D, since B A E + E A D = 90 degrees.

Angle, Obtuse — —An angle whose value is greater than a right angle or 90 degrees.

E A C, Fig. 13, is an obtuse angle.

Angle of Declination or Variation.—(See *Declination, Angle of. Variation, Angle of.*)

Angle of Difference of Phase Between Alternating Currents of Same Period.—(See *Phase, Angle of Difference of, Between Alternating Currents of Same Period.*)

Angle of Dip.—(See *Dip. Dip or Inclination, Angle of.*)

Angle of Inclination.—(See *Dip or Inclination, Angle of.*)

Angle of Lag of Dynamo-Electric Machine.—(See *Lag, Angle of, of Dynamo-Electric Machine.*)

Angle of Lead.—(See *Lead, Angle of.*)

Angle of Variation.—(See *Variation, Angle of.*)

Angle, Plane — —An angle contained between two straight lines.

Angle, Solid — —An angle contained between two surfaces.

Angle, Supplement of — —What an angle needs to make its value 180 degrees, or two right angles.

Thus in Fig. 13, E A C, is the supplement of E A D, because E A D + E A C = 180 degrees, or two right angles.

Angle, Unit — —An angle of 57.29578° or 57° 17' 44.8" nearly.—(See *Velocity, Angular.*)

Angular Currents.—(See *Currents, Angular.*)

Angular Velocity.—(See *Velocity, Angular.*)

Animal Electricity.—(See *Electricity, Animal.*)

Animal Magnetism.—(See *Magnetism, Animal.*)

Anion.—The electro-negative radical of a molecule.

Literally, the term *ion* signifies a group of wandering atoms. An *anion* is that group of atoms of an electrically decomposed or *electrolyzed*

molecule which appears at the *anode*. (See *Electrolysis, Anode*.)

As the anode is connected with the electro-positive terminal of a source, the *anion* is the *electro-negative radical or group of atoms, and therefore appears at the electro-positive terminal*.

A *kation*, or electro-positive radical, appears at the *kathode*, which is connected with the electro-negative terminal of the battery. Oxygen and chlorine are anions. Hydrogen and the metals are kations.

Anisotropic Conductor.—(See *Conductor, Anisotropic*.)

Anisotropic Medium.—(See *Medium, Anisotropic*.)

Annealing, Electric — — A process for annealing metals in which electric heating is substituted for ordinary heating.

Annual Inequality of Earth's Magnetism.—(See *Inequality, Annual, of Earth's Magnetism*.)

Annual Variation of Magnetic Needle.—(See *Needle, Magnetic, Annual Variation of*.)

Annunciator, Burglar-Alarm — — An annunciator used in connection with a system of burglar-alarms. (See *Alarm, Burglar*.)

Annunciator Clock, Electric — — (See *Clock, Electric Annunciator*.)

Annunciator Drop.—(See *Drop, Annunciator*.)

Annunciator Drop, Automatic — — (See *Drop, Automatic Annunciator*.)

Annunciator, Electro-Magnetic — — An electric device for automatically indicating the points or places at which one or more electric contacts have been closed.

The character of the annunciator depends, of course, on the character of the places at which these points, places or stations are situated.

Annunciators are employed for a variety of purposes. In hotels they are used for indicating the number of a room the occupant of which desires some service, which he signifies by pushing a button, thus closing an electric circuit. This is indicated or announced on the annunciator by the falling of a *drop*, on which is printed a number corresponding with the room, and by the

ringing of a bell to notify the attendant. The number is released by the movement of the armature of an electro-magnet. The drops are replaced in their former position by some mechanical device operated by the hand. In the place of a drop a

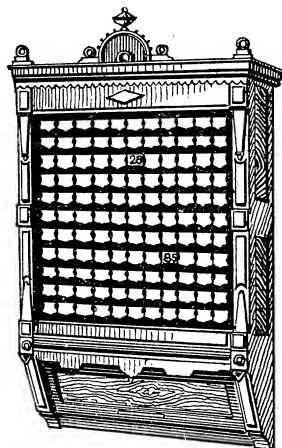

Fig. 14. Electro-Magnetic Annunciator.

needle is sometimes used, which, by the attraction of the armature of an electro-magnet, points to the number signaling.

Annunciators for houses, burglar-alarms, fire-alarms, elevators, etc., are of the same general construction.

Annunciators are generally operated by electro-magnetic attraction or repulsion, and are therefore sometimes called *electro-magnetic annunciators*.

Fig. 14 shows an annunciator suitable for use in hotels.

The numbers 28 and 85 are represented as having been dropped by the closing of the circuit connected with them.

Annunciator, Elevator — — An annunciator connected with an elevator to indicate the floor signaling.



Fig. 15. Elevator Annunciator.

One form of elevator annunciator is shown in Fig. 15.

Annunciator, Fire-Alarm — —An annunciator used in connection with a system of fire-alarms.

Annunciator, Gravity-Drop — —An annunciator whose signals are operated by the fall of a drop.

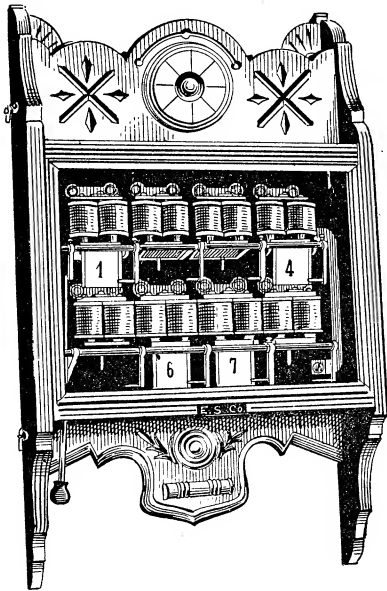

Fig. 16. Gravity-Drop Annunciator.

A form of gravity-drop annunciator is shown in Fig. 16. The armature mechanism for the release of the drop will be understood by an inspection of the drawing.

Annunciator, Hotel — —An annunciator connected with the different rooms of a hotel.

A hotel-annunciator is generally provided with a return bell and guest-call.

Annunciator, House — —An annunciator connected with the rooms of a house.

Annunciator, Needle — —An annunciator, the indications of which are given by the movements of a needle instead of the fall of a drop.

A form of needle-annunciator is shown in Fig. 17.

Annunciator, Oral or Speaking Tube — —An annunciator electrically operated

by means of a puff of breath transmitted through an ordinary speaking tube.

The oral-annunciator is a contrivance whereby a central office is placed in communication with a number of speaking tubes coming from different points in a hotel or other place. A person in any room, who wishes to communicate with the central office, blows through the speaking tube in his room, and thus, by effecting an electric contact, rings a bell and operates a drop at the annunciator, thus indicating the exact tube at which the attendant is to receive the message. The attendant can thus be placed in easy communication with each of the rooms whose speaking tubes connect with the annunciator.

Annunciator, Pendulum or Swinging — —An annunciator, the indicating arm of which consists of a pendulous, or swinging arm,

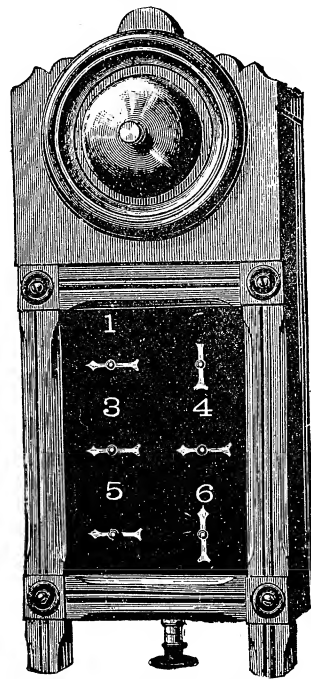

Fig. 17. Needle-Annunciator.

which, when at rest, points vertically downward, and which is moved to the right or left by the action of the current.

Pendulous, or swinging-annunciators are generally so arranged as to need no replacement.

On the cessation of the current the indicator arm drops vertically downward.

A relay is preferably used with pendulum-annunciators, since the rapid makes and breaks of the current by the bell alarm interfere with their satisfactory action.

Anodal.—Pertaining to the anode. (See *Anode.*)

Anodal Diffusion.—(See *Diffusion, Anodal.*)

Anode.—The conductor or plate of a decomposition cell connected with the positive terminal of a battery, or other electric source.

That terminal of an electric source out of which the current flows into the liquid of a decomposition cell or voltameter is called the anode.

That terminal of an electric source into which the current flows from a decomposition cell or voltameter is called the kathode.

The anode is connected with the carbon or positive terminal of a voltaic battery, and the kathode with the zinc, or negative terminal. Therefore the word anode has been used to signify the positive terminal of an electric source, and kathode, the negative terminal, and in this sense is employed generally in electro-therapeutics. It is preferable, however, to restrict the use of the words anode and kathode to those terminals of a source at which electrolysis is taking place.

The terms anode and kathode in reality refer to the electro-receptive devices through which the current flows. Since it is assumed that the current flows out of a source from its positive pole or terminal, and back through the source at its negative pole or terminal, the pole of any device which is connected with the positive pole of a source is the part or place at which the current enters and flows through it, and that connected with the negative pole, the part at which it leaves. Hence, probably, the change in the use of the words already referred to.

Since the *anion*, or the *electro negative radical*, appears at the *anode*, it is the anode of an *electroplating bath*, or the plate connected with the positive terminal of the source, that is dissolved.

When the term *anode* was first proposed by Faraday, voltaic batteries were the only available electric source, and the term referred only to the

positive terminal of a voltaic battery when placed in an electrolyte.

Anodic.—Pertaining to the anode. (See *Anode.*)

Anodic Electro-Diagnostic Reactions.—(See *Reactions, Kathodic and Anodic Electro-Diagnostic.*)

Anodic Opening Contraction.—(See *Contraction, Anodic Opening.*)

Anomalous Magnet.—(See *Magnet, Anomalous.*)

Anomalous Magnetization.—(See *Magnetization, Anomalous.*)

Anti-Induction Cable — — (See *Cable, Anti-Induction.*)

Anti-Induction Conductor.—(See *Conductor, Anti-Induction.*)

Antilogous Pole.—(See *Pole, Antilogous.*)

Anvil.—The front contact of a telegraphic key that limits its motion in one direction. (See *Key, Telegraphic.*)

Aperiodic Galvanometer.—(See *Galvanometer, Aperiodic.*)

Apparatus, Faradic-Induction — — An induction coil apparatus for producing faradic currents.

A voltaic battery is connected with the primary of an induction coil, and its current rapidly broken by an *automatic break*, or by a hand break. The alternating or faradic currents thus produced in the secondary coils are used for electro-therapeutic purposes. (See *Coil, Induction.*)

Faradic induction apparatus is made in a great variety of forms. They all operate, however, on essentially the same principles.

Apparatus, Faradic, Magneto-Electric — — A small magneto-electric machine employed in electro-therapeutics for producing faradic currents.

Magneto-electric faradic machines consist essentially of a coil of wire wrapped on an armature core that is rotated before the poles of permanent magnets. No commutator is employed, since it is desired to obtain rapidly alternating currents.

Apparatus, Interlocking — — Devices for mechanically operating from a distant signal

tower, railroad switches and semaphore signals for indicating the position of such switches, by means of a system of interlocking levers, so constructed that the signals and the switches are so interlocked as to render it impossible, after a route has once been set up and a signal given, to clear a signal for a route that would conflict with the one previously set up. (See *Block System for Railroads.*)

Apparatus, Magneto-Electric Medical — — A term applied to small magneto-electric machines employed in medical electricity for the production of uncommuted or faradic currents. (See *Apparatus, Faradic, Magneto-Electric.*)

Apparatus, Registering, Electric — — Devices for obtaining permanent records by electrical means.

Apparatus, Registering, Telegraphic — — A name sometimes given to a telegraphic recorder. (See *Recorder, Chemical, Bain's Recorder, Morse. Recorder, Siphon.*)

Apparent Co-efficient of Induction. — (See *Induction, Apparent Co-efficient of.*)

Arago's Disc. — (See *Disc, Arago's.*)

Arc. — A voltaic arc. (See *Arc, Voltaic.*)

Arc. — To form a voltaic arc.

A dynamo-electric machine is said to arc at the commutator, when the current passes as visible sparks across the spaces between adjacent segments.

This action at the commutator is more generally called *sparking* or *burning*.

Arc, Alternating — — A voltaic arc formed by means of an alternating current.

In order to avoid the extinction of the arc a certain number of alternations per second is necessary. The alternating arc produces a loud singing noise. At very high frequencies, however, the noise disappears.

The alternating arc, not possessing a fixed positive crater, requires to be covered by a good reflector to throw the light downward.

Arc, Ampère — — A single conductor bent in an arc of a circle, and used in electric balances for measuring the electric current.

Arc Blow-Pipe. — (See *Blow-Pipe, Electric Arc.*)

Arc, Compound — — An arc formed between more than two separate electrodes.

Arc, Counter Electromotive Force of — — An electromotive force generally believed to be set up on the formation of a voltaic arc, opposed in direction to the electromotive force maintaining the arc. (See *Force, Electromotive, Counter.*)

This counter electromotive force is believed to have its origin partly in the energy absorbed at the crater of the positive carbon, where the carbon is volatilized, and given out at the nipple on the negative carbon, where it is deposited or solidified. It is to be noted in this connection that the apparent resistance of the carbon voltaic arc is not directly proportional to the length of the arc.

Arc, Electric — — A term sometimes used for the voltaic arc. (See *Arc, Voltaic.*)

Arc, Frying of — — A frying sound attending the formation of a voltaic arc when the carbons are too near together.

The cause of the frying sound is probably the same as that of hissing. (See *Arc, Hissing of.*)

Arc, Hissing of — — A hissing sound attending the formation of voltaic arcs when the carbons are too near together.

The cause of the hissing is not entirely understood. Prof. Elihu Thomson suggests that it is due to a too rapid volatilization of the carbons.

Arc Lamp. — (See *Lamp, Arc.*)

Arc Lamp, Electric — — (See *Lamp, Electric Arc.*)

Arc Lamp, Triple Carbon Electric — — (See *Lamp, Arc, Triple Carbon Electric.*)

Arc Lighting. — (See *Lighting, Arc.*)

Arc, Metallic — — A voltaic arc formed between metallic electrodes.

When the voltaic arc is formed between metallic electrodes instead of carbon electrodes, a flaming arc is obtained, the color of which is characteristic of the burning metal; thus copper forms a brilliant green arc. The metallic arc, as a rule is much longer than an arc with the same current taken between carbon electrodes.

Arc Micrometer. — (See *Micrometer, Arc.*)

Arc, Noisy — —A voltaic arc, the maintenance of which is attended by frying, hissing, or spluttering sounds.

Arc, Quiet — —A voltaic arc which is maintained without sensible sounds.

Arc, Roaring of — —A roaring sound attending the formation of a voltaic arc when the carbons are too near together and a very powerful current is used.

Arc, Simple — —An arc formed between two electrodes.

Arc, Spluttering of — —A spluttering sound attending the formation of a voltaic arc.

Prof. Elihu Thomson suggests that the cause of spluttering is due to the presence of impurities in the carbons, or from the sudden evolution of gas from insufficiently baked carbons.

Arc, Voltaic — —The brilliant arc or bow of light which appears between the electrodes or terminals, generally of carbon, of a sufficiently powerful source of electricity, when separated a short distance from each other.

The source of light of the electric arc lamp.

It is called the voltaic arc because it was first obtained by the use of the battery invented by Volta. The term arc was given to it from the shape of the luminous *bow* or *arc* formed between the carbons.

To form the voltaic arc the carbon electrodes are first placed in contact and then gradually separated. A brilliant arc of flame is formed between them, which consists mainly of volatilized carbon. The electrodes are consumed, first, by actual combination with the oxygen of the air; and, second, by volatilization under the combined influence of the electric current and the intense heat.

As a result of the formation of the arc, a crater is formed at the end of the positive carbon, and appears to mark the point out of which the greater part of the current flows.

The crater is due to the greater volatilization of the electrode at this point than elsewhere. It marks the position of highest temperature of the electrodes, and is the main source of the light of the arc. When, therefore, the voltaic arc is employed for the purposes of illumination with vertically opposed carbons, the positive carbon should be made the upper carbon, so that the

focus of greatest intensity of the light may be favorably situated for illumination of the space below the lamp. When, however, it is desired to illumine the side of a building *above* an arc lamp, the lower carbon should be made positive.

The positive carbon is consumed about twice as rapidly as the negative, both because the negative oxygen attacks the points of the positive carbon, and because the positive carbon suffers the most rapid volatilization.

The electric current passes through the space occupied by the voltaic arc because—

(1.) The heated arc is a partial conductor of electricity.

(2.) Because small charges of electricity are carried bodily forward from the positive to the negative carbon through the space of the voltaic arc, by means of the minute particles which are volatilized at the positive electrode.

S. P. Thompson has shown that the temperature of the light-emitting surface of the carbon is the temperature of the volatilization of carbon, and is therefore constant.

Dr. Fleming found that “A rise of potential

along the arc takes place very suddenly, just in the neighborhood of the crater.”

The crater in the end of the positive carbon is seen in Fig. 18. On the opposed end of the negative carbon a projection or nipple is formed by the deposit of the electrically volatilized carbon.

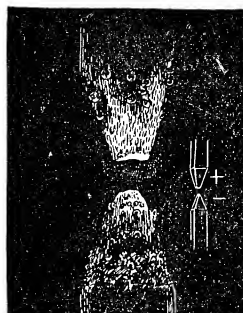

Fig. 18. Voltaic Arc.

The rounded masses or globules that appear on the surface of the electrodes are due to deposits of molten foreign matters in the carbon.

The carbon, both of the crater and its opposed nipple, is converted into pure, soft graphite.

Arc, Voltaic, Resistance of — —The resistance offered by the voltaic arc to the passage of the current.

As in all other conductors, the ohmic resistance of the arc increases with its length, and decreases with its area of cross-section. The apparent resistance, however, is not directly proportional to the length. An increase of temperature decreases the resistance of the voltaic arc.

The total apparent resistance of the voltaic arc is composed of two parts, viz.:

(1.) The true ohmic resistance. (See *Resistance, Ohmic.*)

(2.) The counter electromotive force, or spurious resistance. (See *Resistance, Spurious.*)

Arc, Watt — —A voltaic arc, the electric power of which is equal to a given number of watts.

The ordinary long-arc, as employed in arc lighting, has a difference of potential of about 45 volts and a current strength of about 10 ampères. It is, therefore, a 450-watt arc.

Arc, Auroral — —The archlike form sometimes assumed by the auroral light. (See *Aurora Borealis.*)

Arcing.—Discharging by means of voltaic arcs. (See *Arc, Voltaic.*)

Arcing at the commutator of a dynamo-electric machine not only prevents the proper operation of the machine, but eventually leads to the destruction of the brushes and the commutator.

Areometer, Bead — —A form of areometer suitable for rapidly testing the density of the liquid in a storage cell.

The bead areometer consists of a glass tube, open at both top and bottom, containing a few glass beads, so weighted as to float at liquid densities such as 1.105, 1.170, 1.190 and 1.200. To use the instrument, it is immersed in the liquid of the storage cell, and then withdrawn. The finger being kept in the upper opening, the liquid does not escape through the small opening at the bottom. The density is then ascertained by noting the beads that float.

Areometer or Hydrometer.
—An instrument for determining the specific gravity of a liquid.

A common form of hydrometer consists, as shown in Fig. 19, of a closed glass tube, provided with a bulb, and filled at the lower end with mercury or shot, so as to insure its vertical position when floating in a liquid. When placed in different liquids, it floats with part of the tube out of the liquid. The lighter the liquid, the

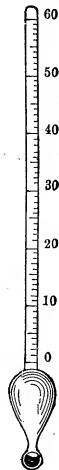

Fig. 19. Hydrometer.

smaller is the portion that remains out of the liquid when the instrument floats. The specific gravity is determined by observing the depth to which the instrument sinks when placed in different liquids, as compared with the depth it sinks when placed in water.

Areometry.—The measurement of specific gravity by means of an areometer.

Argand Burner, Electric Hand-Lighter
— —(See *Burner, Argand, Electric Hand-Lighter.*)

Argand Burner, Electric Plain-Pendant
— —(See *Burner, Plain Pendant, Argand, Electric.*)

Argand Burner, Electric Ratchet-Pendant
— —(See *Burner, Ratchet-Pendant, Argand, Electric.*)

Argyrometry.—The art of determining the weight of electrolytically deposited silver. (See *Balance, Plating.*)

Arm, Balance — —One of the resistances of an electric balance. (See *Arms, Bridge or Balance. Bridge, Electric.*)

Arm, Bridge — —A bridge arm. (See *Arms, Bridge or Balance.*)

Arm, Cross — —A horizontal beam attached to a pole for the support of the insulators for telegraph, electric light or other electric wires.

A telegraphic arm. (See *Arm, Telegraphic.*)

Arm, Rocker — —An arm on which the brushes of a dynamo or motor are mounted for the purpose of shifting their position on the commutator.

Arm, Semaphore — —The movable arm of the signal apparatus employed in block systems for railroads, for the purpose of informing engineers of trains of the condition of the road as regards other trains.

In the absolute block system, as used on some roads, there are two positions for the semaphore arm, viz.:

- (1.) For Danger—when in a horizontal position, or at 90 degrees with the vertical supporting pole.
- (2.) Clear—when dropped below the horizontal position through an angle of 75 degrees.

In the Permissive Block System, a third position

intermediate between the 1st and the 2d, or at an angle of 37 degrees 30 minutes with the horizontal position, is used for caution. (See *Block System for Railroads.*)

Arm, Signal — — A semaphore arm. (See *Arm, Semaphore.*)

Arm, Telegraphic — — A cross-arm placed on a telegraphic pole for the support of the insulators.

These arms are generally called cross-arms.

Armature.—A mass of iron or other magnetizable material placed on or near the pole or poles of a magnet.

In the case of a *permanent magnet*, the armature, when used as a *keeper*, is of soft iron and is placed directly on the magnet poles. In this case it preserves or keeps the magnetism by closing the *lines of magnetic force* of the magnet through the soft iron of the armature, and is then called a *keeper*. (See *Force, Magnetic, Lines of.*)

In the case of an electro-magnet, the armature is placed near the poles, and is moved toward them whenever the magnet is energized by the passage of the current through the magnetizing coils. This movement is made against the action of a spring or weights, so that on the loss of magnetism by the magnet, the armature moves from the magnet poles. (See *Magnet, Permanent, Magnet, Keeper of.*)

When the armature is of soft iron it moves toward the magnet on the completion of the circuit through its coils, no matter in what direction the current flows, and is then called a *non-polarized armature*. (See *Armature, Non-Polarized.*)

When made of *steel*, or of another electro-mag-

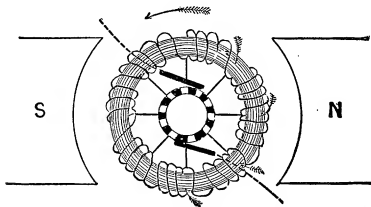

Fig. 20. Bi-polar Armature.

net, it moves from or toward the poles, according to whether the poles of the armature are of the same or of a different polarity from those of the magnet. Such an armature is called a *polarized armature*. (See *Armature, Polarized.*)

Armature, Bi-polar — — An armature of a dynamo-electric machine the polarity of which is reversed twice in every revolution through the field of the machine.

A form of bi-polar armature is shown in Fig. 20. The word bi-polar armature is not generally employed. The term applies rather to the field-magnet poles than to the armature.

Armature Bore.—(See *Bore, Armature.*)

Armature Bore, Elliptical — — (See *Bore, Elliptical Armature.*)

Armature Chamber.—(See *Chamber, Armature.*)

Armature Coils, Dynamo — — (See *Coils, Armature, of Dynamo-Electric Machine.*)

Armature Core, Dynamo — — (See *Core, Armature, of Dynamo-Electric Machine.*)

Armature, Cylindrical — — A term sometimes applied to a drum armature. (See *Armature, Drum. Armature, Dynamo-Electric Machine.*)

Armature, Cylindrical Ring.—A ring armature with a core in the shape of a comparatively long cylinder.

Armature, Disc — — An armature of a dynamo-electric machine, in which the armature coils consist of flat coils, supported on the surface of a disc. (See *Armature, Dynamo-Electric Machine.*)

Armature, Dissymmetrical Induction of — — Any induction produced in the armature of a dynamo-electric machine that is unequal in amount on opposite halves, or in symmetrically disposed portions of the armature.

Dissymmetrical induction in the armature may cause annoying or injurious sparking at the commutator. It may arise—

- (1.) From a lack of symmetry in the amount of the armature windings.
- (2.) From a lack of symmetry in the arrangement of the armature windings on the armature core.
- (3.) From a lack of symmetry of the pole pieces of the machine.
- (4.) From an improper position of the brushes

as regards the neutral point on the commutator, causing a temporary short-circuiting of one or more of the armature coils.

Armature, Drum — — An armature of a dynamo-electric machine, in which the armature coils are wound longitudinally over the surface of a cylinder or drum. (See *Armature, Dynamo-Electric Machine*.)

A form of drum-armature is shown in Fig. 21.

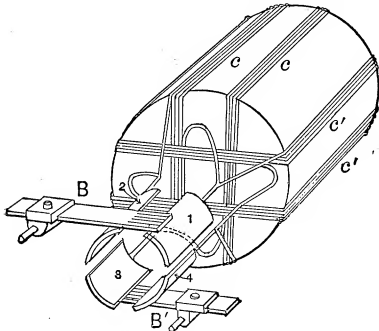

Fig. 21. Drum-Armature.

Armature, Dynamo-Electric Machine — — The coils of insulated wire together with the iron armature core, on or around which the coils are wound.

That part of a dynamo-electric machine in which the differences of potential which cause the useful currents are generated.

Generally, that portion of a dynamo-electric machine which is revolved between the pole pieces of the field magnets.

The armature of a dynamo-electric machine usually consists of a series of coils of insulated wire or conductors, wrapped around or grouped on a central core of iron. The movement of these wires or conductors through the magnetic field of the machine produces an electric current by means of the *electromotive forces* so generated. Sometimes the field is rotated; sometimes both armature and field rotate.

The armatures of dynamo-electric machines are of a great variety of forms. They may for convenience be arranged under the following heads, viz.:

Cylindrical or drum-armatures, disc-armatures, pole-or-radial armatures, ring armatures, and spherical-armatures. For further particulars see above terms. Armatures are also divided

into classes according to the character of the magnetic field through which they move—viz.: unipolar, bipolar, and multipolar armatures.

The English sometimes use the word cylindrical armature as a synonym of ring-armature.

A unipolar-armature is one whose polarity is never reversed. A bipolar-armature is one in which the polarity is reversed twice in every rotation; multipolar armatures have their polarity reversed a number of times in every rotation.

The term armature as applied to a dynamo-electric machine was derived from the fact that the iron core acts to magnetically connect the two poles of the field magnets in the same manner that an ordinary armature connects the poles of a magnet.

Armature, Flat Ring — — A ring-armature with a core in the shape of a short cylindrical ring.

Armature, Girder — — An armature with an H-shaped or girder-like core.

An H-shaped armature.

Armature, Intensity — — An old term for an armature with coils of many turns and of a comparatively high resistance.

Armature, Lamination of Core of — — A division of the iron core of the armature of a dynamo-electric machine or motor, so as to avoid the formation of eddy-currents therein. (See *Core, Lamination of. Currents, Eddy.*)

Armature, Multipolar — — A dynamo-electric machine armature whose polarity is reversed more than twice during each rotation in the field of the machine.

Armature, Neutral — — A non-polarized armature. (See *Armature, Non-Polarized.*)

Armature, Neutral-Relay — — A relay armature, consisting of a piece of soft iron, which closes a local circuit whenever its electro-magnet receives an impulse over the main line. (See *Armature, Polarized.*)

This term is applied in contradistinction to a polarized relay armature.

Armature, Non-Polarized — — An armature of soft iron, which is attracted toward the poles of an electro-magnet on the comple-

tion of the circuit, no matter in what direction the current passes through the coils.

The term non-polarized is used in contradistinction to polarized armature. (See *Armature, Polarized*.)

The non-polarized armature of a relay magnet is generally called the *neutral relay armature*.

Armature of a Cable, or Cable-Armature.—A term sometimes employed for the sheathing or protecting coat of a cable.

The term armor sheathing or coating is preferable.

Armature of a Condenser, or Condenser Armature.—A term sometimes applied to the metallic plates of a condenser or Leyden jar.

The use of this term is unnecessary and ill-advised. The term coating or plate would appear to be preferable.

Armature of Holtz Machine, or Holtz-Machine Armature.—The pieces of paper that are placed on the stationary plate of the Holtz and other similar electrostatic induction machines.

Armature Pockets.—(See *Pockets, Armature*.)

Armature, Polarized — —An armature which possesses a polarity independent of that imparted by the magnet pole near which it is placed.

In permanent magnets the armatures are made of soft iron, and therefore, by *induction*, become of a polarity opposite to that of the magnet poles that lie nearest them. They have, therefore, only a motion of attraction toward such poles. (See *Induction, Magnetic*.)

In electro-magnets the armatures may either be made of soft iron, in which case they are attracted only on the passage of the current; or they may be formed of permanent steel magnets, or may be electro-magnets themselves, in which case the passage of the current through the coils of the electro-magnet, or electro-magnets, may cause either attraction or repulsion, according as the adjacent poles are of opposite polarity or are of the same polarity.

Armature, Pole — —An armature the coils of which are wound on separate poles

that project radially from the periphery of a disc, drum or ring.

A pole-armature showing the arrangement of

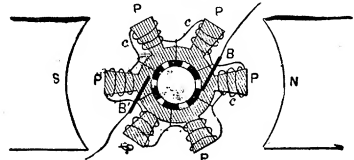

Fig. 22. Pole-Armature.

the coils and their connection to the commutator segments is seen in Fig. 22.

Armature, Quantity — —An old term for an armature wound with but a few coils of comparatively low resistance.

Armature, Radial — —A term sometimes used instead of pole-armature. (See *Armature, Pole*.)

Armature, Ring — —A dynamo-electric machine armature, the coils of which are wound on a ring-shaped core.

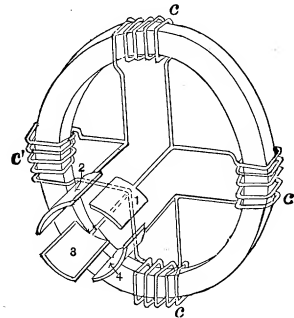

Fig. 23. Ring-Armature.

A ring-armature is shown in Fig. 23, together with the disposition of the coils and their connection to the segments of the commutator.

Armature, Shuttle — —A variety of drum armature in which a single coil of wire is wound in an H-shaped groove formed in a bobbin shaped core.

The old form of Siemens-armature.

Armature, Single-Loop — —A closed conducting circuit consisting of a single loop, capable of revolving in a magnetic field so as to cut its lines of force.

Armature, Spider.—(See *Spider, Armature*.)

Armature, Spherical — —A dynamo-electric machine armature, the coils of which are wound on a spherical iron core.

The Thomson-Houston dynamo, which is the only machine employing an armature of this type, has its armature formed by wrapping three coils of insulated wire on a core of iron so shaped as to insure an approximately spherical armature when wrapped.

Armature, Toothed-Ring — —An armature, the core of which is in the shape of a ring, provided with a number of teeth in the spaces between which the armature coils are placed.

Armature, Unipolar — —A dynamo-electric machine armature whose polarity is not reversed during its rotation in the field of the machine.

Armature, Ventilation of — —A process for insuring the free passage of air through the armature of a dynamo-electric machine in order to prevent overheating.

Armor of Cable.—(See *Cable, Armor of.*)

Armored Cable.—(See *Cable, Armored.*)

Armored Conductor.—(See *Conductor, Armored.*)

Arms, Bridge or Balance — —The electric resistances, in the electric balance or bridge. (See *Bridge, Electric.*)

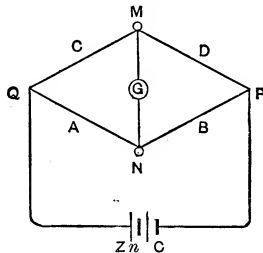

Fig. 24. Arms of Balance.

An unknown resistance, such, for example, as D, Fig. 24, is measured by proportioning the known resistances, A, C and B, so that no current flows through the galvanometer G, across the circuit or bridge M G N.

Arms, Proportionate — —The two resistances or arms of an electric bridge whose relative or proportionate resistances only are required to be known in order to determine,

in connection with a known resistance, the value of an unknown resistance placed in the remaining arm of the bridge.

Thus is Fig. 24, A and B, are the proportionate arms.

Arrangement or Device, Electromotive

— —A term sometimes employed to represent a dynamo-electric machine, voltaic cell or other electric source, by means of which electromotive force can be produced.

Electric sources do not produce electric currents, but differences of potential or electromotive force. Electric sources are therefore very properly termed electromotive devices.

Arrester, Lightning — —A device by means of which the apparatus placed in any electric circuit is protected from the destructive effects of a flash or bolt of lightning.

In the phenomena of *lateral induction* and *alternative path*, we have seen the tendency of a *disruptive* discharge to take a short-cut across an intervening air space, rather than through a longer though better conducting path. Most lightning arresters are dependent for their operation on this tendency to lateral discharge. (See *Induction, Lateral. Path, Alternative.*)

A form of lightning arrester is shown in Fig. 25.

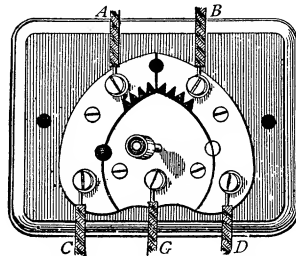

Fig. 25. Comb Lightning-Arrester.

The line wires, A and B, are connected by two metallic plates to C and D, respectively.

These plates are provided with points, as shown, and placed near a third plate, connected to the ground by the wire G. Should a bolt strike the line, it is discharged to the earth through the wire G.

Various forms are given to lightning arresters of this type. The projections are sometimes placed on the ground connected plate as well as on the plates connected to line wires. This form is sometimes called a *comb arrester*, or *protector*.

Arrester, Lightning, Comb — —A term sometimes applied to a lightning arrester in which both the line and ground plates are furnished with a series of teeth, like those on a comb. (See *Arrester, Lightning.*)

Arrester, Lightning, Counter-Electromotive Force — —A lightning arrester, in which the passage of the discharge through the instruments to be protected is opposed by a counter-electromotive force, generated by induction on the passage of the discharge of the bolt to earth.

The counter-electromotive force lightning arrester is an invention of Professor Elihu Thomson. It assumes a variety of forms. In the shape shown in Fig. 26, the line circuit of the dynamo,

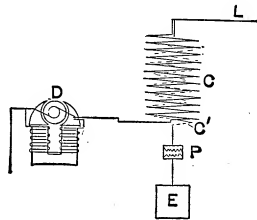

Fig. 26. Counter-Electromotive Force Lightning Arrester.

D, has one end connected to ground, and the other end has two conducting paths to ground. One of these paths is through the ordinary comb-protector at P, by the ground plate E; this circuit includes a few turns of wire C'. The other path is through a corresponding coil C, either interior or exterior to C', so as to be within its inductive field. As will be seen from the figure, C, is connected through the machine to the ground. The induction coils C and C', are thoroughly insulated from each other.

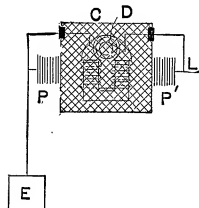

Fig. 27. Counter-Electromotive Force Lightning Arrester.

The induction coils C and C', are thoroughly insulated from each other.

Should a lightning flash or other static discharge pass through the circuit C', which is of comparatively low self-induction, a counter-electromotive force is produced in the other coil C, which protects the line circuit.

In the form of lightning arrester shown in Fig. 27, the coil in the path of the direct lightning discharge is formed into an exterior mesh or net work surrounding the dynamo to be protected. In this case, the coils of the dynamo act as the secondary coils in which the counter electromotive force is set up.

Arrester, Lightning, Transformer — —A form of lightning arrester designed for the protection of transformers.

The Thomson arrester for transformers operates on the same principle as his arc-line protector. In the latter the arc, when formed, is blown out by the action of the field of an electro-magnet. This arc is formed on curved metallic bows, one of which is connected to line and the other to earth. The arc is formed at the smallest interval between the bows, and is extinguished by being driven by action of a magnetic field toward greatest interval.

Arrester Plate of Lightning Protector. — (See *Plate, Arrester, of Lightning Protector.*)

Arrester Plates. — (See *Plates, Arrester.*)

Articulate Speech. — (See *Speech, Articulate.*)

Artificial Carbons. — (See *Carbons, Artificial.*)

Artificial Illumination. — (See *Illumination, Artificial.*)

Artificial Line. — (See *Line, Artificial.*)

Artificial Magnet. — (See *Magnet, Artificial.*)

Asphyxia. — Suspended respiration, resulting eventually in death, from non-aeration of the blood.

In cases of asphyxia by an electric shock a species of asphyxia is sometimes brought about. This is due, probably, to the failure of the nerves and muscles that carry on respiration. The exact manner in which death by electrical shock results is not known. (See *Death, Electric.*)

Assymmetrical Resistance. — (See *Resistance, Assymmetrical.*)

Astatic. — Possessing no directive power.

Usually applied to a magnetic or electro-magnetic device which is free from any tendency to take a definite position on account of the earth's magnetism.

Astatic Circuit.—(See *Circuit, Astatic.*)

Astatic Couple.—See *Couple, Astatic.*)

Astatic Galvanometer.—(See *Galvanometer, Astatic.*)

Astatic Needle.—(See *Needle, Astatic.*)

Astatic Pair.—(See *Pair, Astatic.*)

Astatic System.—(See *System, Astatic.*)

Astronomical Meridian.—(See *Meridian, Astronomical.*)

Asymptote of Curve.—(See *Curve, Asymptote of.*)

Atmosphere, An — —A unit of gas or fluid pressure equal to about 15 pounds to the square inch.

At the level of the sea the atmosphere exerts a pressure of about 15 pounds avoirdupois, or, more accurately, 14.73 pounds, on every square inch of the earth's surface. This value has therefore been taken as a unit of fluid pressure.

For more accurate measurements pounds to the square inch are employed.

In the metric system of weights and measures an atmosphere is considered equal to 1,033 grammes per square centimetre.

Atmospheric pressures are measured by instruments called *Manometers*. (See *Manometer.*)

Atmosphere, Residual — —The traces of air or other gas remaining in a space which has been exhausted of its gaseous contents by a pump or other means.

It is next to impossible to remove all traces of air from a vessel by any known form of pump or other appliance. (See *Vacuum, Absolute.*)

Atmosphere, The — —The ocean of air which surrounds the earth.

The atmosphere is, approximately, composed, by weight, of oxygen 23 parts, and nitrogen 77 parts. Besides these there are from 4 to 6 parts in 10,000 of carbonic acid gas (or about a cubic inch of carbonic acid to a cubic foot of air), and varying proportions of the vapor of water.

The oxygen, nitrogen and carbonic acid form the constant ingredients of the atmosphere, the vapor of water the variable ingredient. There are in most localities a number of other variable ingredients present as impurities.

Atmospheric Electricity.—(See *Electricity, Atmospheric.*)

Atmospheric Electricity, Origin of — —(See *Electricity, Atmospheric, Origin of.*)

Atom.—The smallest quantity of elementary or simple matter that can exist.

An ultimate particle of matter.

Atom means that which cannot be cut. It is generally believed that material atoms are absolutely unalterable in size, shape, weight and density; that they can neither be cut, scratched, flattened, nor distorted; and that they are unaffected in size, density, or shape, by heat or cold, or by any known physical force.

Although almost inconceivably small, atoms nevertheless possess a definite size and mass. According to Sir William Thomson, the smallest visible organic particle, 1-4000 of a millimetre in diameter, will contain about 30,000,000 atoms.

Atom, Closed-Magnetic Circuit of — —(See *Circuit, Closed-Magnetic, of Atom.*)

Atom, Gramme — —Such a number of grammes of any elementary substance as is numerically equal to the atomic weight of the substance.

The gramme-atom of a substance represents the number of *calories* required to raise the temperature of one gramme of that substance through 1 degree C. (See *Heat, Atomic, Calorie.*) Thus, in the case of chlorine, whose atomic weight is 35.5, its gramme-atom is 35.5; consequently 35.5 small calories of heat would be required to raise one gramme-atom of chlorine through 1 degree C.

Atom of Electricity.—(See *Electricity, Atom of.*)

Atom, Vortex — —A number of particles of the universal ether moving in the manner of a vortex ring.

The theory of vortex atoms, so formed from vortex rings, was propounded by Sir William Thomson in order to explain how a readily movable substance, like the universal ether, could be made to possess the properties of a rigid solid. If it be granted that a vortex motion has once been imparted to the universal ether, Thomson shows that such rings would be indestructible. (See *Matter, Thomson's Hypothesis of.*)

Atomic Attraction. — (See *Attraction, Atomic.*)

Atomic Capacity.—(See *Capacity, Atomic.*)

Atomic Currents.—(See *Currents, Atomic.*)

Atomic Energy.—(See *Energy, Atomic.*)

Atomic Heat.—(See *Heat, Atomic.*)

Atomic or Molecular Induced Currents.
—(See *Currents, Induced, Molecular or Atomic.*)

Atomic Weight.—(See *Weight, Atomic.*)

Atomicity.—The combining capacity of the atoms.

The relative equivalence of the atoms or their atomic capacity.

The elementary atoms do not always combine atom for atom. Some single atoms of certain elements will combine with two, three, four, or even more atoms of another element.

The value of the atomic capacity of an atom is also called its *quivalence* or *valency*.

Elements whose atomic capacity is—

One,	are called Monads,	or Univalent.
Two,	“ Dyads,	“ Bivalent.
Three,	“ Triads,	“ Trivalent.
Four,	“ Tetrads,	“ Quadrivalent.
Five,	“ Pentads,	“ Quinquivalent.
Six,	“ Hexads,	“ Sexivalent.
Seven,	“ Heptads,	“ Septivalent.

Atomization.—The act of obtaining liquids in a spray of finely divided particles.

In most cases the term is not literally correct, as each of the smallest particles so obtained usually consist of many thousands of atoms.

Atomize.—To separate into a fine spray by means of an atomizer. (See *Atomizer.*)

Atomizer.—An apparatus for readily obtaining a finely divided jet or spray of liquid.

A jet of steam, or a blast of air, is driven across the open end of a tube that dips below the surface of the liquid to be atomized. The partial vacuum so formed draws up the liquid, which is then blown by the current into a fine spray.

Attract.—To draw together.

Attracted-Disc Electrometer.—(See *Electrometer, Attracted-Disc.*)

Attracting.—Drawing together.

Attraction.—Literally the act of drawing together.

In science the name attraction is given to a series of unknown causes which effect, or are assumed to effect, the drawing together of atoms, molecules or masses.

Attraction and repulsion underlie nearly all natural phenomena. While their effects are well known, it is doubtful if anything is definitely known of their true causes.

Since attraction, pure and simple, necessitates the belief in action at a distance, an action which is now generally discredited, we must, strictly speaking, regard the term attraction as being but a convenient substitution of the effect for the cause.

It would appear much more reasonable to regard the effects of attraction as produced by a true push exerted from the outside of the bodies. According to this notion, two masses of matter undergoing attraction are pushed together rather than drawn or attracted together.

It has been suggested that gravitation may perhaps be an effect of a longitudinal motion or vibratory thrust in the universal ether. If this is the case, and the ether is sensibly incompressible, the velocity of gravitation, it would appear, should be almost infinite.

Attraction, Atomic — —The attraction which causes the atoms to combine. (See *Affinity, Chemical.*)

In the opinion of Lodge, atomic attraction is the result of the attraction of dissimilar charges of electricity possessed by all atoms, which are capable of uniting or entering into chemical combination. (See *Electricity, Atom of.*)

Attraction, Capillary — —The molecular attractions that are concerned in capillary phenomena. (See *Capillarity.*)

Attraction, Electro-Dynamic — —The mutual attraction of electric currents, or of conductors through which electric currents are passing. (See *Dynamics, Electro.*)

Attraction, Electro-Magnetic — —The mutual attraction of the unlike poles of electro-magnets. (See *Magnet, Electro.*)

Attraction, Electrostatic — —The mutual attraction exerted between unlike electric charges, or bodies possessing unlike electric charges.

For example, the pith ball supported on an insulated string is attracted, as shown at A, Fig. 28,

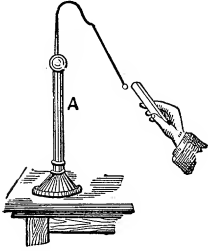

Fig. 28. *Electrostatic Attraction.*

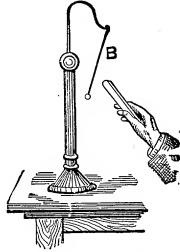

Fig. 29. *Electrostatic Repulsion.*

by a bit of sulphur which has been briskly rubbed by a piece of silk. As soon, however, as the ball touches the sulphur and receives a charge, it is repelled, as shown at B, Fig. 29.

These attractions and repulsions are due to the effects of *electrostatic induction*. (See *Induction, Electrostatic.*)

Attraction, Magnetic — — The mutual attraction exerted between unlike magnet poles.

Magnetic attractions and repulsions are best shown by means of the *magnetic needle* N S, Fig. 30. The N. pole of an approached magnet

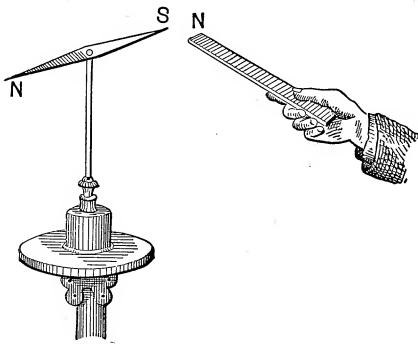

Fig. 30. *Magnetic Attraction.*

attracts the S. pole of the needle but repels the N. pole.

The laws of magnetic attraction and repulsion may be stated as follows, viz.:

(1.) Magnet poles of the same name repel each other; thus, a north pole repels another north pole, a south pole repels another south pole.

(2.) Magnet poles of unlike names attract each other; thus a north pole attracts a south pole, or a south pole attracts a north pole.



Fig. 31. *Floating Magnet.*

A small bar magnet, N S, Fig. 31, laid on the top of a light vessel floating on the surface of a liquid, may be readily employed to illustrate the laws of magnetic attraction and repulsion.

Attraction, Mass — — The mutual attraction exerted between masses of matter. (See *Gravitation.*)

Attraction, Molar — — A term sometimes employed for mass attraction.

Gravitation is an example of mass attraction, where the mass of the earth attracts the mass of some body placed near it. (See *Gravitation.*)

Attraction, Molecular — — The mutual attraction exerted between neighboring molecules.

The attraction of like molecules, or those of the same kind of matter, is called *Cohesion*; that of unlike molecules, *Adhesion*.

The tensile strength of iron or steel is due to the cohesion of its molecules. Paint adheres to wood, or ink to paper, by cohesion or the attraction between the unlike molecules.

Attraction of Gravitation.—A term generally applied to the mutual attraction between masses. (See *Gravitation.*)

Attractions and Repulsions of Currents.—(See *Currents, Attractions and Repulsions of.*)

Audiphone.—A thin plate of hard rubber held in contact with the teeth, and maintained at a certain tension by strings attached to one of its edges, for the purpose of aiding the hearing.

The plate is so held that the sound-waves from a speaker's voice impinge directly against its flat surface. It operates by means of some of the waves being transmitted to the ear directly through the bones of the head.

The audiphone is sometimes called a *denti-phon*.

Aural Electrode.—(See *Electrode, Aural.*)

Aurora Australis.—The Southern Light. A name given to an appearance in the south-

ern heavens similar to that of the Aurora Borealis. (See *Aurora Borealis*.)

Aurora Borealis.—The Northern Light.

Luminous sheets, columns, arches, or pillars of pale, flashing light, generally of a red color, seen in the northern heavens.

The auroral light assumes a great variety of appearances, to which the terms *auroral arch, bands, corona, curtains and streamers* are applied.

The exact cause of the aurora is not as yet known. It would appear, however, beyond any reasonable doubt, that the auroral flashes are due to the passage of electrical discharges through the upper, and therefore rarer, regions of the atmosphere. The intermittent flashes of light are probably due to the discharges being influenced by the earth's magnetism.

Auroras are frequently accompanied by *magnetic storms*. (See *Storm, Magnetic*.)

The occurrence of auroras is nearly always simultaneous with that of an unusual number of *sun spots*. Auroras are therefore probably connected with outbursts of the solar energy. (See *Spots, Sun*.)

The auroral light examined by the spectroscope gives a *spectrum* characteristic of luminous gaseous matter, *i. e.*, contains a few bright lines; but, according to S. P. Thompson, this spectrum is produced by matter that is not referable with certainty to that of any known substance.

Whatever may be the exact cause of auroras, their appearance is almost exactly reproduced by the passage of electric discharges through vacua.

Aurora Polaris.—A general term sometimes applied to aurora in the neighborhood of either pole, or in either the northern or the southern hemisphere.

Auroral Arch.—(See *Arch, Auroral*.)

Auroral Bands.—(See *Bands, Auroral*.)

Auroral Corona.—(See *Corona, Auroral*.)

Auroral Curtain.—(See *Curtain, Auroral*.)

Auroral Flashes.—(See *Flashes, Auroral*.)

Auroral Light.—(See *Light, Auroral*.)

Auroral Storm.—(See *Storm, Auroral*.)

Auroral Streamer.—(See *Streamer, Auroral*.)

Auroras and Magnetic Storms, Peri-

odicity of — — Observed coincidences between the occurrence of auroras, magnetic storms, and sun-spots.

The occurrence of auroras, or magnetic storms, at periods of about eleven years apart, corresponds to the well-known *eleven-year sun-spot period*.

The period also agrees with a variation in the magnetic declination of any place, which, according to Sabine, occurs once in every eleven years.

Austral Magnetic Pole.—(See *Pole, Magnetic, Austral*.)

Autographic Telegraphy.—(See *Telegraphy, Autographic*.)

Automatic Annunciator Drop.—(See *Drop, Annunciator, Automatic*.)

Automatic Bell.—(See *Bell, Automatic Electric*.)

Automatic Contact Breaker.—(See *Contact Breaker, Automatic*.)

Automatic Cut-Out.—(See *Cut-Out, Automatic*.)

Automatic Cut-Out for Multiple-Connected Electro-Receptive Devices.—(See *Cut-Out, Automatic, for Multiple-Connected Electro-Receptive Devices*.)

Automatic Cut-Out for Series-Connected Electro-Receptive Devices.—(See *Cut-Out, Automatic, for Series-Connected Electro-Receptive Devices*.)

Automatic Drop.—(See *Drop, Automatic*.)

Automatic Electric Burner.—(See *Burner, Automatic Electric*.)

Automatic Electric Safety System for Railroads.—(See *Railroads, Automatic Electric Safety System for*.)

Automatic Fire-Alarm.—(See *Alarm, Fire, Automatic*.)

Automatic Gas Cut-Off.—(See *Cut-Off, Automatic Gas*.)

Automatic Indicator.—(See *Indicator, Automatic*.)

Automatic Make-and-Break.—(See *Make-and-Break, Automatic*.)

Automatic Oiler.—(See *Oiler, Automatic*.)

Automatic Paper-Winder.—(See *Winder, Telegraphic Paper.*)

Automatic Regulation.— See *Regulation, Automatic.*)

Automatic Regulator.—(See *Regulator, Automatic.*)

Automatic Search-Light.—(See *Light, Search, Automatic.*)

Automatic Switch for Incandescent Electric Lamp.—(See *Switch, Automatic, for Incandescent Electric Lamp.*)

Automatic Telegraphy.—(See *Telegraphy, Automatic.*)

Automatic Telephone Switch.—(See *Switch, Telephone, Automatic.*)

Automatic Time Cut-Outs.—(See *Cut-Out, Automatic Time.*)

Automatic Variable Resistance.—(See *Resistance, Variable, Automatic.*)

Automatically Regulable.—(See *Regulable, Automatically.*)

Automobile Torpedo.—(See *Torpedo, Automobile.*)

Average or Mean Electromotive Force.—(See *Force, Electromotive, Average, or Mean.*)

Axes of Co-ordinates.—(See *Co-ordinates, Axes of.*)

Axial Magnet.—(See *Magnet, Axial.*)

Axis, Magnetic — — The line around which a magnetic needle, free to move, but which has come to rest in a magnetic field, can be turned without changing the set or direction in which it has come to rest.

Axis, Magnetic, of a Straight Needle — — A straight line drawn through the magnet, joining its poles.

The magnetic axis of a straight needle may be regarded as a straight line passing through the poles of the needle and its point of support.

The magnetic axis may not correspond with the geometric axis of the needle. This leads to an error in reading the true direction in which the needle is pointing, which must be corrected. Thus, the needle N S, Fig. 32, points to 31 degrees on the scale. In reality, if the magnetic axis of the needle lies in the line N' S', the true deflection of the needle is only 28 degrees.

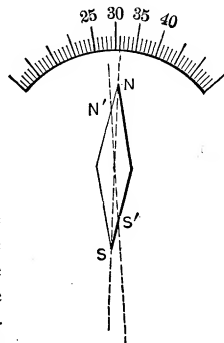

Fig. 32. Magnetic Axis.

Axis of Abscissas.—(See *Abscissas, Axis of.*)

Axis of Ordinates.—(See *Ordinates, Axis of.*)

Azimuth.—In astronomy, the angular distance between an azimuth circle and the meridian.

The azimuth of a heavenly body in the Northern Hemisphere is measured on the arc of the horizon intercepted between the north point of the horizon and the point where the great circle that passes through the heavenly body cuts the horizon.

Azimuth Circle.—(See *Circle, Azimuth.*)

Azimuth Compass.—(See *Compass, Azimuth.*)

Azimuth, Magnetic — — The arc intercepted on the horizon between the magnetic meridian and a great circle passing through the observed body.

B

B.—A contraction used in mathematical writings for the internal magnetization, or the magnetic induction, or the number of lines of force per square centimetre in the magnetized material.

This contraction for internal magnetization is,

in most mathematical treatises, printed in bold-faced type.

B. A. Ohm.—(See *Ohm, B. A.*)

B. A. U.—A contraction sometimes employed for the British Association unit or ohm.

B. W. G.—A contraction for Birmingham wire gauge. (See *Gauge, Birmingham Wire*.)

A contraction sometimes used for the new British wire gauge.

Back Electromotive Force.—(See *Force, Electromotive, Back*.)

Back-Stroke of Lightning.—(See *Lightning, Back-Stroke of*.)

Bain's Chemical Recorder.—(See *Recorder, Chemical, Bain's*.)

Bain's Printing Solution.—(See *Solution, Bain's Printing*.)

Balance Arms.—(See *Arms, Bridge or Balance*.)

Balance, Bi-filar Suspension — —An instrument similar in construction to Coulomb's torsion balance, but in which the needle is hung by two separate fibres instead of by a single one. (See *Balance, Coulomb's Torsion. Suspension, Bi-filar*.)

Balance, Centi-Ampère — —An ammeter in the form of a balance, whose scale is graduated to give direct readings in centi-ampères.

Ampère balances giving readings in various decimals or multiples of ampères have been devised by Sir William Thomson. The strength of current passing is determined by the action on a movable ring or coil, placed between two fixed rings or coils.

The movable ring is in a horizontal plane nearly midway between the two fixed rings. The fixed rings are traversed by the current in opposite directions, so that one attracts and the other repels the movable ring. The movable ring is attached to one end of a horizontal balance arm, and a similar movable ring, also provided with attracting and repelling fixed rings, is attached to the opposite end of the balance arm. In order to avoid disturbance of horizontal components of terrestrial, or of local magnetic force, the current is sent in the same direction through the two movable rings. The balancing is effected by means of a weight, sliding on a nearly horizontal arm attached to the balance. A counterpoise weight is used in connection with the sliding weight.

A standard Thomson centi-ampère balance is shown in Fig. 33. In measuring a current,

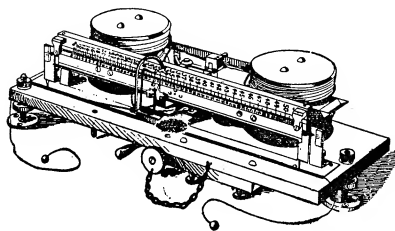

Fig. 33. Centi-Ampère Balance.

the weight is moved along the scale until the balance comes to rest.

Balance, Composite — —A balance form of ammeter devised by Sir William Thomson, which can be used for an ampère-meter, a watt-meter, or a volt-meter, according to the manner in which its sets of fine and coarse wire coils are connected. (See *Balance, Centi-Ampère*.)

Balance, Coulomb's Torsion — —An apparatus to measure the force of electric or magnetic repulsion between two similarly charged bodies, or between two similar magnet poles, by opposing to such force the torsion of a thin wire.

The two forces *balance* each other; hence the origin of the name.

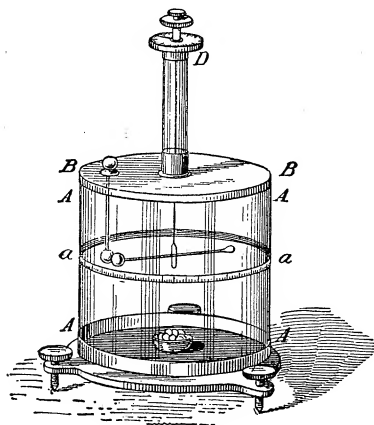

Fig. 34. Coulomb's Torsion Balance.

Fig. 34 represents a Coulomb torsion balance, adapted to the measurement of the force

of electrostatic repulsion. A delicate needle of shellac, having a small gilded pith ball at one of its ends, is suspended by a fine metallic wire. A proof-plane, B, is touched to the electrified surface whose charge is to be measured, and is then placed as shown in the figure. (See *Plane, Proof.*) There is a momentary attraction of the needle, and then a repulsion, which causes the needle to be moved a certain distance from the ball on the proof-plane. This distance is measured in degrees on a graduated circle a, marked on the instrument. The force of the repulsion is calculated by determining the amount of torsion required to move the needle a certain distance toward the ball of the electrified proof-plane.

This torsion is obtained by the movement of the torsion head D, the amount of which motion is measured on a graduated circle at D. The measurement is based on the fact that the force required to twist a wire is proportional to the angle of torsion.

Balance, Deci-Ampère — — An ammeter in the form of a balance, whose scale is graduated to give direct readings in deci-ampères. (See *Balance, Centi-Ampère.*)

Balance, Deka-Ampère — — An ammeter in the form of a balance, whose scale is graduated to give direct readings in deka-ampères. (See *Balance, Centi-Ampère.*)

Balance, Electric — — A term frequently used for Wheatstone's electric bridge. (See *Bridge, Electric.*)

The electric bridge is sometimes called a balance because, when in use in measuring resistances, one resistance or set of resistances balances another resistance or set of resistances.

Balance, Hekto-Ampère — — An ammeter in the form of a balance, whose scale is graduated to give direct readings in hekto-ampères. (See *Balance, Centi-Ampère.*)

Balance Indicator.—(See *Indicator, Balance.*)

Balance, Induction, Hughes' — — An apparatus for the detection of the presence of a metallic or conducting substance by the aid of induced electric currents.

Hughes' induction balance is shown in Fig. 35.

A, B, C and D are bobbins, wound with about 300 feet of No. 32 copper wire. The coils are

connected as shown, A and B, in the circuit of a battery, and C and D, in the circuit of a telephone. The coils, A and B, and C and D, are placed at

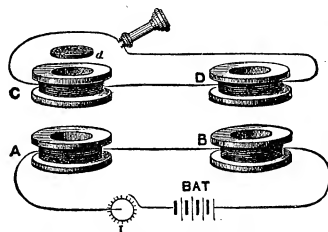

Fig. 35. Hughes' Induction Balance.

such a distance apart as to prevent any mutual induction occurring between them. The coils are so joined that the direction of the induction of A, on C, is opposite to that of B, on D.

The coils, A and B, then act as primaries, and C and D, as secondaries. In the battery circuit is an interrupter I, which is caused to continually make and break the circuit.

The coils are so adjusted that the opposing secondary coils produce but little noise to one listening at the telephone. This can readily be done by the adjusting of a single pair of coils.

If a single coin or mass of metal be introduced between either A and C, or B and D, or even above one of the coils, as at d, the balance will be disturbed, since some of the induction is now expended in producing electric currents in the interposed metal, and a sound will therefore be heard in the telephone. But if precisely similar metals are placed in similar positions, between A and C, and B and D, no sound is heard in the telephone, since the inductive effects due to the two metals are the same.

The slightest difference, however, either in composition, size or position, destroys the balance, and causes a sound to be heard in the telephone.

A spurious coin is thus readily detected when compared with a genuine coin.

A somewhat similar instrument has been employed to detect and locate a bullet or other foreign metallic substance in the human body.

In order to determine the amount of the disturbance, an instrument called a sonometer is used (See *Sonometer, Hughes'*), in which a single secondary coil, placed in the circuit of a telephone, slides on a graduated bar between two fixed primary coils, so wound as to exert equal and opposite inductions on the secondary. When, therefore, the secondary is exactly in the middle of the

graduated bar, and consequently exactly midway between the two fixed primary coils, no sounds are heard in the telephone, but when moved to one side or the other the sounds are heard. Switches are so arranged that the telephone can be readily switched from the induction balance to the telephone, or *vice versa*. When, therefore, a metallic disc is placed in one of the coils of the induction balance, and a noise is heard in the telephone, the coil of the sonometer is shifted so that the noise heard in this telephone is judged by the ear to be equal, and the comparison can then be made by means of simple calculations.

The following table gives, in arbitrary values, the results of various experiments as to the sensitiveness in this respect of discs of different metals, of various sizes and shapes:

Silver, chemically pure.....	125
Gold.....	117
Silver, commercial.....	115
Aluminium.....	112
Copper.....	100
Zinc.....	80
Bronze.....	75
Tin.....	74
Iron, ordinary.....	53
German silver.....	50
Iron, pure.....	40
Copper, alloyed.....	40
Lead.....	58
Antimony.....	35
Bismuth.....	10
Zinc, alloyed.....	6
Carbon.....	2

—(*Fleming*.)

An inspection of this table shows that the values found for different metals do not correspond with their electric conducting power, although, roughly speaking, the best conductors stand at the top of the table, and the worst at the bottom. The effects appear to be dependent for their action on the phenomena of magnetic screening, for—

(1.) If slots are cut in the middle of the plate its disturbing action is either removed or very much decreased.

(2.) If a flat coil of copper wire replaces a disc of metal no effect is produced on the induction balance when its ends are open, but when closed the coil acts just like a disc, or continuous plate of metal.

(3.) The difference between various metals in-

serted as discs in the induction balance is less at high speeds of reversal than at low speeds.

Balance, Kilo-Ampère — — An ammeter in the form of a balance, whose scale is graduated to give direct readings in kilo-amperes. (See *Balance, Centi-Ampère*.)

Balance of Induction in Cable.—(See *Induction, Balance of, in Cable*.)

Balance, Plating — — An automatic device for disconnecting the current from the article to be plated, as soon as a certain increase in weight has been obtained.

The objects to be plated are suspended at one end of a balance, and when a certain increase in weight has been gained, the balance tips and breaks the circuit. Edison's electric meter is based on this principle.

Balance, Thermic, or Bolometer.—An apparatus constructed on the principle of the differential galvanometer, devised by Professor Langley for determining small differences of temperature. (See *Galvanometer, Differential*.)

A coil composed of two separately insulated wires, wound together, is suspended in a magnetic field, and has a current sent through it. Under normal conditions, this current separates into two equal parts, and runs through the wires in opposite directions. It therefore produces no sensible field, and suffers no deflection by the field in which it is suspended.

Any local application of heat producing a difference in temperature in these coils, causing a difference in resistance, prevents this equality. A field is therefore produced in the suspended coil, which, though extremely small, is rendered measurable by means of the powerful field produced in the coil, within which the double coil is suspended.

Differences of temperature as small as one-fourteenth thousandth of a degree Fahrenheit are detected by the instrument.

Balance, Wheatstone's Electric — — A name often given to the electric bridge or balance. (See *Bridge, Electric*.)

Balanced-Metallic Circuit.—(See *Circuit, Balanced-Metallic*.)

Balanced Resistances.—(See *Resistances, Balanced*.)

Balata.—An insulating material.

Balata, when prepared for use as an insulating material, is somewhat like gutta-percha.

Ball, Electric Time — —A ball, supported in a prominent position on a tall pole, and caused to fall at the exact hour of noon, or at any other predetermined time, for the purpose of thus giving correct time to an entire neighborhood.

The release of the ball is effected by the closing of an electric circuit, either automatically, or through the agency of an observer.

Ball, Fire — —A term sometimes applied to globular lightning. (See *Lightning, Globular.*)

Ball Lightning.—(See *Lightning, Ball.*)

Ballistic Curve.—(See *Curve, Ballistic.*)

Ballistic Galvanometer.—(See *Galvanometer, Ballistic.*)

Balloon, Electric — —A balloon, or air ship, provided with electric power so as to be able to be steered or moved against the direction of the wind.

Electric balloons have been moved against the wind and steered with a certain amount of success, by the use of electric motors driven by storage batteries. All that is needed to make aerial navigation a commercial success is the ability to obtain great power with a small weight. The storage battery does this to a limited extent.

Bearing in mind the high efficiency of the electric motor, it would appear that the problem of successful aerial navigation will be solved when the discovery is made of means for directly converting the chemical potential energy of coal into electrical energy.

Balloon Signaling for Military Purposes.—(See *Signaling, Balloon, for Military Purposes.*)

Balls, Pith — —Two balls of pith, suspended by conducting threads of cotton to insulated conductors, employed to show the electrification of the same by their mutual repulsion.

The pith balls connected with the insulated cylinder A B, Fig. 36, not only show the electrification of the cylinder, but serve also to roughly

indicate the peculiarities of distribution of the charge thereon.

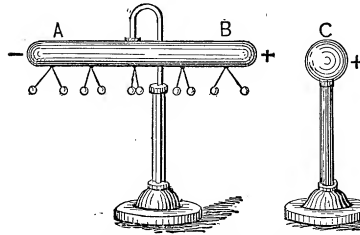

Fig. 36. Pith Ball Cylinder.

Bands, Auroral — —Approximately parallel streaks of light sometimes seen during the prevalence of the aurora. (See *Aurora Borealis.*)

Bank of Lamps.—(See *Lamps, Bank of.*)

Banked Battery.—(See *Battery, Banked.*)

Bar, Detorsion — —A bar placed in a magnetic instrument called a declinometer for the purpose of removing the torsion of the suspending thread of the magnet.

The detorsion bar of the declinometer is generally made of gun metal of the same weight as that of the suspended magnet. A small magnet is placed in a rectangular aperture in the middle of the bar.

Bar Electro-Magnet.—(See *Magnet, Electro, Bar.*)

Barad.—A unit of pressure proposed by the British Association.

One barad equals one dyne per square centimetre.

Barometer.—An apparatus for measuring the pressure or weight of the atmosphere.

Barometric Column.—(See *Column, Barometric.*)

Bars, Bus — —Omnibus bars. (See *Bars, Omnibus.*)

Bars, Krizik's — —Cores of various shapes, provided for solenoids, in which the distribution of the metal in the bar is so proportioned as to insure as nearly as possible a uniform attraction or pull while in different positions in the solenoid.

Krizik's bars of various shapes are shown in Fig. 37. It will be observed that in all cases the

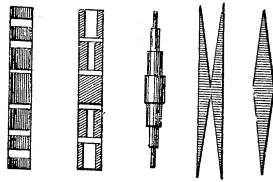

Fig. 37. Krizik's Bars.

mass of metal is greater toward the middle of the core than near the ends.

When a core of uniform diameter is drawn into a solenoid, the attraction or pull is not uniform in strength for different positions of the bar. When the bar is just entering the solenoid, the pull is strongest; as soon as the end passes the middle of the core the attraction decreases, until, when the centres of the bar and core coincide, the motion ceases, since both ends of the solenoid attract equally in opposite directions. By proportioning the bars, as shown in the figure, a fairly uniform pull for a considerable length may be obtained.

Bars, Negative-Omnibus — —The bus-bars that are connected with the negative terminal of the dynamos. (See *Bars, Omnibus.*)

Bars, Neutral-Omnibus — —The bus-bars that are connected with the neutral dynamo terminal in a three-wire system of distribution.

Bars, Omnibus — —Heavy bars of conducting material connected directly to the poles of dynamo-electric machines, in electric incandescent light or electric railway installations, and therefore receiving the entire current produced by the machine.

Main conductors common to two or more dynamos in an electrical generating plant.

The terms bus and omnibus bars refer to the fact that the entire or whole current is carried by them.

Bars, Positive-Omnibus — —The bus-bars that are connected with the positive terminal of the dynamos.

Bath, Bi-polar — —An electro-therapeutic bath, the current applied to which enters at one part of the tub, and leaves at another part.

The electrodes for the bi-polar bath consist of suitably shaped copper plates, generally called *shovel electrodes*.

Bath, Copper — —An electrolytic bath containing a readily electrolyzable solution of a copper salt, and a copper plate acting as the anode, and placed in the liquid near the object to be electro-plated, which forms the kathode. (See *Plating, Electro.*)

The sulphate, the cyanide and the acetate of copper are used for copper baths. The use of the sulphate is objectionable. The cyanide is expensive. The acetate is therefore very generally employed. Wahl gives the following formula for a copper bath, viz.:

Water.....	1,000 parts.
Acetate of copper, crystallized.....	20 "
Carbonate of soda.....	20 "
Bisulphite of soda.....	20 "
Cyanide of potassium (pure)	20 "

Bath, Electro-Plating — —Tanks containing metallic solutions in which articles are placed so as to be electro-plated. (See *Plating, Electro.*)

Strictly speaking a plating bath includes not only the vessel and its metallic solution, but also the metallic plate acting as the anode and the article to be plated forming the kathode.

Bath, Electro-Therapeutic — —A bath furnished with suitable electrodes and used in the application of electricity to curative purposes.

Such baths should be used only under the advice of a regular physician.

Bath, Gold — —An electrolytic bath containing a readily electrolyzable solution of a gold salt and a gold plate acting as the anode, and placed in the liquid opposite the object to be plated, which forms the kathode. (See *Plating, Electro.*)

Electro gilding may be accomplished either with or without the aid of heat. Hot gilding appears to give a smoother and cleaner deposit.

The following is a fairly good solution for a gold bath:

Water.....	1,000 parts.
Cyanide of potassium, pure..	20 "
Gold.....	10 "

—(Wahl.)

The gold is first converted into neutral chloride by dissolving it in 25 parts of pure hydrochloric acid to which 12.5 parts of pure nitric acid has been added. When the gold is completely dissolved, the liquid is heated until of a dark red color, in order to expel any excess of acid.

Bath, Head, Electric — —A variety of electric breeze, applied therapeutically to the head of the patient.

The patient is placed on an insulating stool and connected with one pole of an electrostatic induction machine, the other pole of which is connected to a circle of insulated points suspended over the head.

Bath, Hydro-Electric — —A bath in which electro-therapeutic treatment is given by applying one electrode to the metallic lining of the tub, and the other electrode to the body of the bather.

Bath, Multipolar-Electric — —An electro-therapeutic bath, in which more than two electrodes are employed.

It is not clear that the multipolar-electric bath possesses any decided advantages over the bi-polar bath.

Bath, Nickel — —An electrolytic bath containing a readily electrolyzable salt of nickel, a plate of nickel acting as the anode of a battery and placed in the liquid near the object to be coated, which forms the kathode. (See *Plating, Electro.*)

The double sulphate of nickel and ammonium (from 5 to 8 parts dissolved in 100 parts of water) is used for the bath. Some prefer to add sulphate of ammonium and citric acid to the above solution.

Bath, Shower, Electric — —A shower bath in which the falling drops carry electric charges to the patient subjected thereto.

The water is rendered slightly alkaline. One pole is immersed in the alkaline water and the other connected to a metallic stool on which the patient is placed.

Bath, Silver — —An electrolytic bath containing a readily electrolyzable salt of silver and a plate of silver acting as the anode of an electric source and placed in the liquid near the object to be coated, which forms the kathode. (See *Plating, Electro.*)

The double cyanide of silver and potassium is the salt usually employed in the silver bath.

The following bath is recommended by Roseleur:

Water	1,000 parts.
Cyanide of potassium (pure)	50 “
Pure silver	25 “

The silver (granulated) is treated with pure nitric acid (43 degrees Beaumé) and converted into nitrate of silver. The solution is then heated to dryness and subsequently fused. The fused nitrate so obtained is dissolved in fifteen times its weight of distilled water and treated with a solution of cyanide of potassium (10 per cent. of the cyanide), by means of which silver cyanide is thrown down as a precipitate. This precipitate is then separated and washed. It is added to the 1,000 parts of water, dissolved, and the cyanide of potassium afterward added, thus forming the double cyanide required for the bath.

Bath, Stripping — —A bath for removing an electro-plating of gold, silver, or other metal, either by simple dipping or by electric action.

Bath, Ungilding — —A stripping bath suitable for the removal of a coating of gold. (See *Bath, Stripping.*)

Bath, Unipolar-Electric — —An electro-therapeutic bath, the water of which forms one of the electrodes of the source, and the other electrode is attached to a metallic rod fixed at a convenient height above the tub.

The bath tub is formed of non-conducting substances. The terminals of the electrode connected with the water terminate in metal plates located at suitable points in the tub. The current is applied by the patient making and breaking contact at the vertical metal rod with his hands.

The unipolar-electric bath is employed instead of local galvanization where it is desired to limit the application to especial organs or particular parts of the body. In general galvanization the patient is placed on an electrode of large surface, formed of a large sponge-covered metallic plate, on which he sits or rests. This electrode is connected with the kathode of the battery. The anode is connected with a large sponge electrode, which is moved regularly over the body of the patient; sometimes the moistened hand of the operator is used in place of the sponge electrode.

Bath, Unsilvering — —A stripping bath suitable for the removal of a coating of silver. (See *Bath, Stripping*.)

Bathometer.—An instrument invented by Siemens for obtaining deep-sea soundings without the use of a sounding line.

The bathometer depends for its operation on the varied attraction of the earth for a suspended weight in parts of the ocean differing in depth. As the vessel passes over deep portions of the ocean, the solid land of the bottom, being further from the ship, exerts a smaller attraction than it would in shallow parts, where it is nearer; for, although in the deep parts of the ocean the water lies between the ship and the bottom, the smaller density of the water as compared with the land causes it to exert a smaller attraction than in the shallower parts, where the bottom is nearer the ship. The varying attraction of the earth is caused to act on a mercury column, the reading of which is effected by means of an electric contact.

Battery, Banked — —A term sometimes applied to a battery from which a number of separate circuits are supplied with currents.

The term banked-battery is sometimes applied to a multiple-arc connected battery.

Battery, Cautery — —A term sometimes employed in electro-therapeutics, for a multiple connected voltaic battery adapted for producing electric incandescence for cautery effects.

Battery, Closed-Circuit — —A voltaic battery which may be kept constantly on closed-circuit without serious polarization.

The gravity battery is a closed-circuit battery. As employed for use on most telegraph lines, it is maintained on a closed circuit. When an operator wishes to use the line he opens his switch, thus breaking the circuit and calling his correspondent. Such batteries should not polarize. (See *Cell, Voltaic, Polarization of*.)

Battery, Connection of, for Quantity — —A term, now generally in disuse, formerly employed to indicate the grouping of voltaic cells, now known as parallel or multiple.

The arrangement or coupling of a number of voltaic cells in multiple reduces the internal resist-

ance of the battery, and thus permits a greater current, or quantity, of electricity to pass; hence the origin of the term.

Battery, Dynamo — —The combination or coupling together of several separate dynamo-electric machines so as to act as a single electric source.

The dynamos may be connected to the leads either in series, in multiple, in multiple-series or in series-multiple.

Battery, Dynamo, Electric Machine — —A dynamo battery. (See *Battery, Dynamo*.)

Battery, Electric — —A general term applied to the combination, as a single source, of a number of separate electric sources.

The separate sources may be coupled either in series, in multiple, in multiple-series, or in series-multiple. (See *Circuits, Varieties of*.)

The term battery is sometimes incorrectly applied to a single voltaic couple or cell.

Battery, Floating, De la Rive's — —A floating voltaic cell, the terminals of which are connected with a coil of insulated wire, employed to show the attractions and repulsions between magnets and movable electric circuits.

The cell, shown in Fig. 38, consists of a vol-

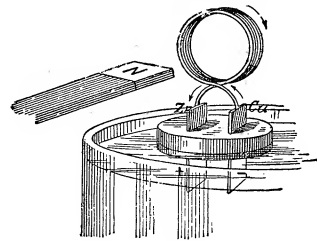

Fig. 38. Floating Cell.

taic couple of zinc and copper, the terminals of which are connected to the circular coil of insulated wire, as shown, and the whole floated by means of a cork, in a vessel containing dilute sulphuric acid.

When the current flows through the coil in the direction shown by the arrows, the approach of the N-seeking pole of a magnet will cause the cell to be attracted or to move towards the magnet pole, since the south face or end of the coil is nearer the north pole of the magnet. If the other

end were nearer, repulsion would occur, the cell turning round until the south face is nearer the magnet, when attraction occurs.

This is, strictly speaking, a floating cell, and not a battery. (See *Battery, Voltaic*.)

Battery, Galvanic — — Two or more separate voltaic cells so arranged as to form a single source.

This is more correctly called a *Voltaic Battery*. (See *Battery, Voltaic*.)

Battery, Gas — — A battery in which the voltaic elements are gases as distinguished from solids.

The electrodes of a gas battery generally consist of plates of platinum, or other solid substance which possesses the power of occluding oxygen and hydrogen. The lower parts of these plates dip into dilute sulphuric acid, and the upper parts are respectively surrounded by oxygen and hydrogen gas derived from the electrolytic decomposition of the dilute acid.

A gas battery consisting of plates of platinum dipping below into acid liquid, and surrounded in the space above the liquid by hydrogen and oxygen H, H' and O, O', etc., respectively is shown in Fig. 39.

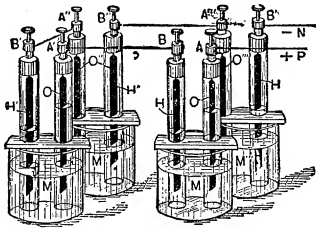

Fig. 39. Gas Battery.

In charging this battery an electric current is sent through it until a certain quantity of the gases has been produced. If, then, the charging current be discontinued, a current in the opposite direction is produced by the battery. The gas battery is in reality a variety of *storage battery*. (See *Electricity, Storage of. Cell, Secondary. Cell, Storage*.)

Gas batteries can also be made by feeding continually into the cell a gas capable of acting on the positive elements.

Battery Gauge.—(See *Gauge, Battery*.)

Battery, Leyden Jar — — The combination of a number of separate Leyden jars so as to act as one single jar.

A Leyden jar battery is shown in Fig. 40,

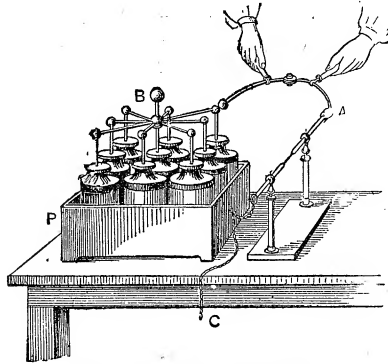

Fig. 40. Leyden Jar Battery.

where nine separate Leyden jars are connected as a single jar by joining their outer coatings by placing them in the box P, the bottom of which is lined with tin foil. The inner coatings are connected together by the metal rods B, as shown.

A *discharging rod* A, may be employed for connecting the opposite coatings. The handles are made of glass or any other good insulating material.

A number of Leyden jars can be coupled in series by connecting the inner coating of the first jar to the outer coating of the second, the inner coating of the second to the outer coating of the third, and so on. The battery so obtained is then discharged by connecting the outer coating of the first jar with the inner coating of the last.

Battery, Local — — A voltaic battery used at a station on a telegraph line to operate the Morse sounder, or the registering or recording apparatus, at that point only. (See *Telegraphy, American or Morse System of*.)

The local battery is thrown into or out of action by the telegraphic *relay*. (See *Relay*.)

Battery, Magnetic — — The combination, as a single magnet, of a number of separate magnets.

A magnetic battery, or compound magnet, is

shown in Fig. 41. It consists of straight bars of steel, p, p, p, with their similar poles placed near together and inserted in masses of soft iron, N and S, as shown.

Battery, Main —

The battery, in a system of telegraphic communication, that is employed for sending the signals over the main line, as distinguished from any battery employed for any other particular work, such, for example, as that of the local battery. (See *Battery, Local*.)

Battery, Multiple-Connected — A battery the single cells of which are connected to one another and to the mains or conductors in multiple. (See *Circuit, Multiple*.)

Battery, Open-Circuit — A voltaic battery which is normally on open-circuit, and which is used continuously only for comparatively small durations of time on closed-circuit.

Leclanché-cells form an excellent open-circuited battery. They have a comparatively high electromotive force, but rapidly polarize. They cannot therefore be economically used for furnishing currents continuously for long durations of time. When left on open-circuit, however, they readily depolarize. They therefore form an excellent battery for such work as annunciator bells, burglar alarms, etc., where the current is only required for short periods of time, separated by comparatively long intervals of rest. (See *Cell, Voltaic, Leclanché*.)

Battery Plates of Secondary or Storage Cell, Forming of — (See *Plates of Secondary or Storage Cell, Forming of*.)

Battery, Plunge — A number of separate voltaic cells connected so as to form a single cell or electric source, the plates of which are so supported on a horizontal bar as to be capable of being simultaneously placed in, or removed from, the exciting liquid.

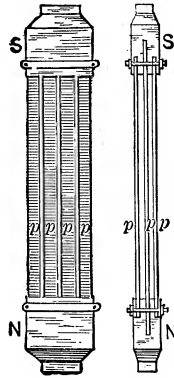

Fig. 41. Magnetic Battery, or Compound Magnet.

The plunge battery shown in Fig. 42, consists

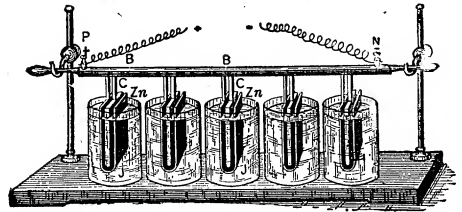

Fig. 42. Plunge Battery.

of a number of zinc-carbon elements immersed in an electrolyte of dilute sulphuric acid, or in *electropoison liquid*, contained in separate jars, J, J. (See *Liquid, Electropoison*.)

The mode of support to the horizontal bar will be understood from an inspection of the drawing.

Battery, Primary — The combination of a number of separate primary cells so as to form a single source.

The term *primary battery* is used in order to distinguish it from secondary or storage battery. (See *Cell, Secondary, Cell, Storage*.)

Battery, Secondary — The combination of a number of separate secondary or storage cells, so as to form a single electric source. (See *Electricity, Storage of*.)

Battery, Selenium — The combination of a number of separate selenium cells so as to form an electric source. (See *Cell, Selenium*.)

Battery, Series-Connected — A battery, the separate cells of which are connected to one another and to the line or conductor in series. (See *Circuit, Series*.)

Battery Solution.—(See *Solution, Battery*.)

Battery, Split — A voltaic battery connected in series, but having one of its middle plates connected with the ground.

By the employment of the device of a split-battery, the poles of the battery are maintained at potentials differing in opposite directions from the potential of the earth.

Battery, Storage — A number of separate storage cells connected so as to form a single electric source.

A cell of a storage battery is shown in Fig. 43.

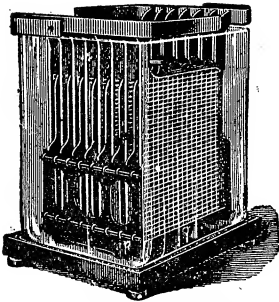

Fig. 43. Storage Battery.

Battery, Storage, Element of — — A single set of positive and negative plates of a storage cell connected so as to be ready for placing in the acid liquid of the jar or cell.

A term sometimes applied to one of the storage cells in a storage battery.

This latter use of the term element is unfortunate, since from the analogous case of a primary cell, an element would consist of a single plate, either positive or negative, and not of both. That is, every voltaic couple consists of two elements, the positive and the negative.

Battery, Thermo — — A term often applied to a thermo-electric battery. (See *Battery, Thermo-Electric*.)

Battery, Thermo-Electric — — The combination, as a single thermo-electric cell, of a number of separate thermo-electric cells or couples. (See *Couple, Thermo-Electric*.)

Battery, Voltaic — — The combination, as a single source, of a number of separate voltaic cells.

Battery, Water — — A battery formed of zinc and copper couples immersed in an electrolyte of ordinary water.

Any voltaic couple can be used, the positive element of which is slightly acted on by water. When numerous couples are employed considerable difference of potential can be obtained.

Water batteries are employed for charging electrometers. They are not capable of giving any considerable current, owing to their great internal resistance.

Bead Areometer or Hydrometer.—(See *Areometer, Bead*.)

Bec-Carcel.—The Carcel, or French unit of light. (See *Carcel*.)

Bell, Automatic-Electric — — An electric bell furnished with an automatic contact-breaker. (See *Contact-Breaker, Automatic*.)

A form of automatic-electric bell is shown in Fig. 44. The relation of the electro-magnet, its armature and the bell lever, will be readily understood from an inspection of the drawing.

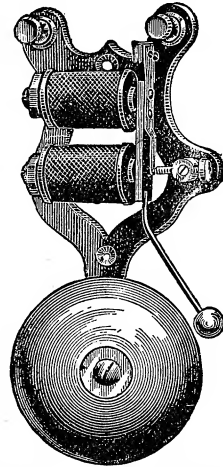

Fig. 44. Automatic Electric Bell.

Bell, Call — — An electric bell used to call the attention of an operator to the fact that his correspondent wishes to communicate with him.

Bell, Circular — — A bell so constructed that all its moving parts are contained in

Bell, Continuous-Sounding Electric — — An electric bell, which, on the completion of the circuit, continues striking until stopped either by hand or automatically.

On the completion of the circuit, the attraction of an armature throws a catch off from a lever, and thus permits the lever to fall and complete a contact and allows the current to ring the bell; or the bell is rung by clockwork, which is thrown into action by the passage of a current through an electro-magnet. (See *Bell, Electro-Mechanical*.)

Bell, Differential Electric — — An electric bell, the magnetizing coils of which are differentially wound.

Differential winding is of advantage where a very strong current is required, as this winding decreases the sparking at the contacts, on the opening of the circuit.

Bell, Electro-Magnetic, Siemens-Armature Form — — A form of electro-mag-

netic bell in which the movements of the bell armature are obtained by the reversal of polarity that takes place when alternating currents are passed through the coils of a simple, single coil, Siemens-armature.

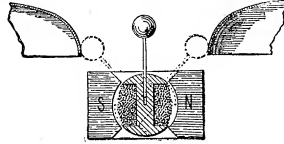

Fig. 45. Siemens-Armature Form of Electro-Magnetic Bell.

The details will be readily understood from an examination of Fig. 45.

Bell, Electro-Mechanical — —A bell, the striking apparatus of which is driven by a weight or spring, called into action by the movement of the armature of an electro-magnet. (See *Alarm, Electric*.)

Bell, Extension-Call — —A device for prolonging the sound of a magneto call.

An alarm bell is automatically connected with

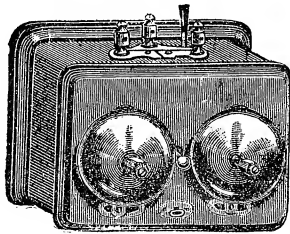

Fig. 46. Extension-Call Bell.

the circuit of a local battery by means of the current generated by the magneto-call, and continues sounding after the current of the magneto call has ceased.

A form of extension-call bell is shown in Fig. 46.

Bell, Indicating — —An electric bell in which, in order to distinguish between different bells in the same office, a number is displayed by each bell when it rings.

Bell, Magneto-Electric — —An electric bell, the current employed to operate or strike which is obtained by the motion of a magneto-electric machine.

Bell, Night — —In a telephone exchange, a bell, switched into connection with the shunted circuit of an annunciator case, and intended, by its constant ringing, to call the attention of the night operator to the falling of a drop.

Bell, Relay, Electric — —An electric bell in which a relay magnet is employed to switch a local battery into the circuit of the sounding apparatus of the bell.

The relay bell is suitable for use when the bell to be sounded is situated at a great distance. As the current from the line, when this is long, is too weak to ring the bell, it throws into action a local battery by the action of a relay.

Relay bells were used in the early forms of acoustic telegraphs as employed in England with relay sounders.

The dots and dashes of the Morse alphabet were indicated by the sounds of two bells, a tap on one bell indicating a dot, and a tap on the other a dash. This system is now practically abandoned.

Bell-Shaped Magnet.—(See *Magnet, Bell-Shaped*.)

Bell, Shunt, Electric — —An electric bell, the magnetizing coils of which are placed on the line in shunt.

In the case of shunt-connected electric bells, one of the bells must make and break the circuit for all the rest. The series-connected electric bell is used where the distance between the separate bells is great, in order to save the expense of multiple connections.

In most cases, where a number of electric bells are to be simultaneously sounded, connection in multiple is adopted.

Bell, Single-Stroke Electric — —An electric bell that gives a single stroke only for each make of the circuit.

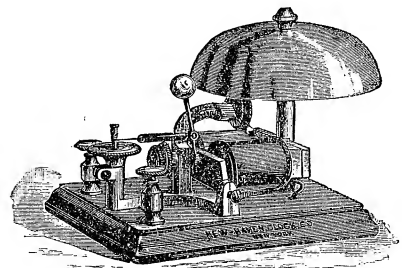

Fig. 47. Single-Stroke Bell.

Since the bell gives a single stroke for each completion of the circuit, its use permits of ready communication between any two places by any

system of prearranged signals. A buzzer may be used for the same purpose. A form of single-stroke bell is shown in Fig. 47. On completing the circuit, the current, through its coils, attracts the armature and causes a single stroke of the bell.

Bell, Telephone-Call — —A call bell used to call a correspondent to the telephone.

The telephone-call bell is generally a magneto-electric bell.

Bell, Trembling — —A name sometimes given to a vibrating or an automatic make-and-break bell. (See *Make-and-Break, Automatic.*)

Bell, Vibrating — —A trembling bell. (See *Bell, Trembling.*)

Bias of Relay Tongue.—(See *Tongue, Relay, Bias of.*)

Bichromate Voltaic Cell.—(See *Cell, Voltaic, Bichromate.*)

Bi-filar Suspension.—(See *Suspension, Bi-filar.*)

Bi-filar Suspension Balance.—(See *Balance, Bi-filar Suspension.*)

Bi-filar Winding.—(See *Winding, Bi-filar.*)

Binary Compound.—(See *Compound, Binary.*)

Binding Coils.—(See *Coils, Binding.*)

Binding-Post.—(See *Post, Binding.*)

Binding-Screw.—(See *Screw, Binding.*)

Binding Wire for Telegraph Lines.—(See *Wire, Binding, for Telegraph Lines.*)

Biology, Electro — —That branch of electric science which treats of the electric conditions of living animals and plants, and the effects of electricity upon them.

Electro-Biology includes :

- (1.) Electro-Physiology.
- (2.) Electro-Therapy, or Electro-Therapeutics.

Bioplasm.—Any form of living matter possessing the power of reproduction.

Bioscopy, Electric — —The determination of the presence of life or death by the passage of electricity through the nerves and muscles.

Bi-polar.—Having two poles.

Bi-polar Armature.—(See *Armature, Bi-polar.*)

Bi-polar Bath.—(See *Bath, Bi-polar.*)

Birmingham Wire Gauge.—(See *Gauge, Wire, Birmingham.*)

Bi-Telephone.—(See *Telephone, Bi.*)

Bitite.—A variety of insulating material.

Black Electro-Metallurgical Deposit.—(See *Deposit, Black Electro-Metallurgical.*)

Black Lead.—A variety of carbon employed in various electrical processes.

Black lead is also termed *plumbago* or *graphite*. (See *Plumbago, Graphite.*)

The term black lead is a misnomer, since the substance is carbon and not lead. The term is an old one, and is still very generally used.

Blasting, Electric — —The electric ignition of powder or other explosive material in a blast. (See *Fuse, Electric.*)

The current required for the ignition of the fuse is generally obtained by means of a magneto-electric machine. In the form of magneto-blasting machine, shown in Fig. 48, the movement

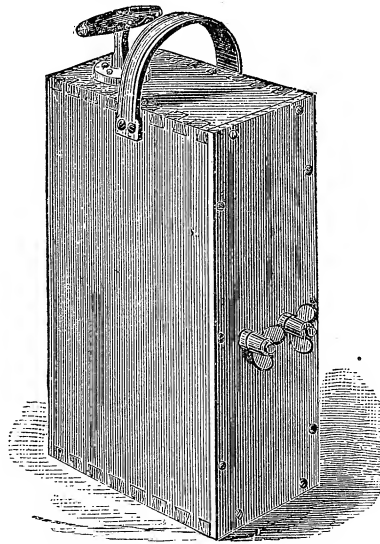

Fig. 48. Magneto-Blasting Machine.

of the handle shown at the top of the figure causes the rapid rotation of a cylindrical armature constructed on the Wheatstone and Siemens principle. The magnets are of iron, and are furnished

with coils of insulated wire. On the rotation of the armature the current developed therein increases the field of the field magnet, and, when of the proper degree of intensity, is thrown into the outer circuit, and ignites the fuse.

Bleaching, Electric — — Bleaching processes in which the bleaching agents are liberated, as required, by the agency of electrolytic decomposition.

In the process of Naudin and Bidet, the current from a dynamo-electric machine is passed through a solution of common salt between two closely approached electrodes. The chlorine and sodium thus liberated react on each other and form sodium hypochloride, which is drawn off by means of a pump and used for bleaching. (See *Electrolysis*.)

Block, Branch — — A device employed in electric wiring for taking off a branch from a main circuit. (See *Wiring*.)

A form of branch-block, with its fuses attached, is shown in Fig. 49.

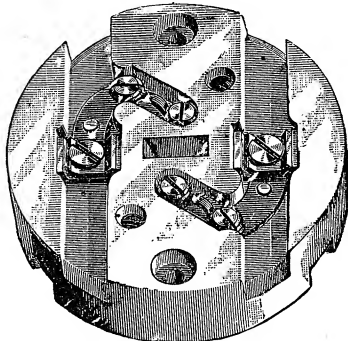

Fig. 49. Branch-Block.

Block, Cross-Over — — A device to permit the safe crossing of one wire over another in molding or cleat wiring.

Block, Fuse — — A block containing a safety fuse or fuses for incandescent light circuits. (See *Fuse, Safety*.)

Block System for Railroads.—(See *Railroads, Block System for*.)

Block Wire.—(See *Wire, Block*.)

Blow-Pipe, Electric — — A blow-pipe in which the air-blast is obtained by a stream of air particles produced at the point of a

charged conductor by a convection discharge.

The candle flame, Fig. 50, is blown in the di-

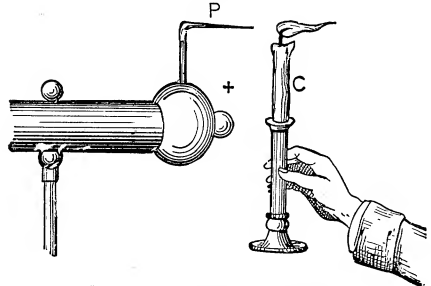

Fig. 50. Convection Blow-Pipe.

rection of the stream of air particles passing off from the point P. (See *Convection, Electric*.)

Blow-Pipe, Electric-Arc — — A device of Werdermann for cutting rocks, or other refractory substances, in which the heat of the voltaic arc is directed, by means of a magnet, or a blast of air, against the substance to be cut.

The carbons are placed parallel, so as to readily enter the cavity thus cut or fused. This invention has never been introduced into extensive practice.

In the welding process of Benardos and Olzewski, the welding temperature is obtained by means of an electric arc taken between two suitably shaped electrodes.

In the electric-arc blow-pipe, shown in Fig. 51, the voltaic arc, taken between two vertical carbon electrodes, is deflected into a horizontal position under the influence of the inclined poles of a powerful electro-magnet.

The highly heated carbon vapor which constitutes the voltaic arc is deflected by the magnet in the same direction as would be any other movable circuit or current.

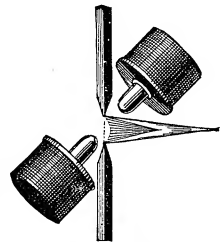

Fig. 51. Electric-Arc Blow-Pipe.

Board, Cross-Connecting — — In a system of telegraphic or telephonic communication, a board to which the line terminals are run before entering the switchboard, so as to

readily place any subscriber in connection with any desired section of the switchboard.

Board, Fuse — —A board of slate or other incombustible material on which all the safety fuses in an installation are assembled.

The fuse board is used for avoiding accidents from the firing of the fuses.

Board, Hanger — —A form of board provided for the ready placing or removal of an arc lamp from a circuit.

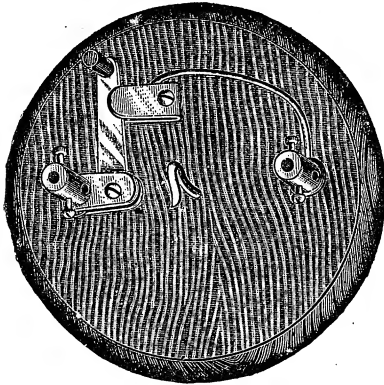

Fig. 52. Hanger-Board.

A hanger-board contains a switch or cut-out for the ready opening or closing of the circuit. A form of hanger-board is shown in Fig. 52.

Board, Key — —Any board to which are connected electric keys or switches.

Board, Legging-Key — —A key board employed for the purpose of legging an operator into a circuit connecting two or more subscribers. (See *Leg.*)

Board, Multiple Switch — —A board to which the numerous circuits employed in systems of telegraphy, telephony, annunciator or electric light and power circuits are connected.

Various devices are employed for closing these circuits, or for connecting or cross-connecting them with one another, or with neighboring circuits.

A multiple switchboard, for example, for a telephone exchange, will enable the operator to connect any subscriber on the line with any other subscriber on that line, or on another neighbor-

ing line provided with a multiple switchboard. To this end the following parts are necessary:

(1.) Devices whereby each line entering the exchange can readily have inserted in its circuit a loop connecting it with another line. This is accomplished by placing on the switchboard a separate *spring-jack* connection for each separate line. This connection consists essentially of one or two springs made of any conducting metal, which are maintained in metallic contact when the plug key is not inserted, but which are readily separated from one another by the introduction of the *plug-key*, Fig. 53, the terminals, a and b, of which are insulated from each other, and are connected to the ends of a loop coming from another line. As the key is inserted, the metallic spring or springs of the spring-jack are separated and the metallic pieces, a and b, are brought into good sliding contact therewith, thus introducing the loop into the circuit. (See *Spring-Jack.*)

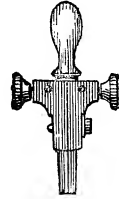

Fig. 53. Plug-Key.

(2.) As many separate annunciator-drops as there are separate subscribers. These are provided so as to notify the Central Office of the particular subscriber who desires a connection. Alarm-bells to call the operator's attention to the calling subscriber, or to the falling of a drop, are generally added. (See *Bell, Call.*)

(3.) Connecting cords and keys for connecting the operator's telephone, and means for ringing subscribers' bells, and clearing out drops.

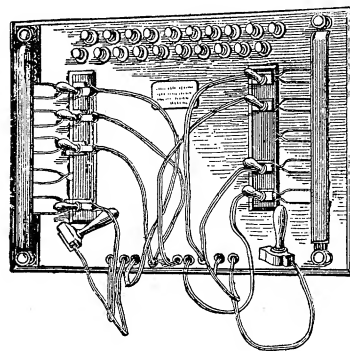

Fig. 54. Multiple Switchboard for Electric Light.

In *Multiple Switchboards* for the *Electric Light* or *Distributing Switches*, spring-jack contacts are connected with the terminals of different circuits,

and plug switches with the dynamo terminals. By these means, any dynamo can be connected with any circuit, or a number of circuits can be connected with the same dynamo, or a number of separate dynamos can be placed in the same circuit without interference with the lights.

Board, Switch — —A board provided with a switch or switches, by means of which electric circuits connected therewith may be opened, closed, or interchanged.

Board, Switch, Telegraphic — —A device employed at a telegraph station by means of which any one of a number of telegraph instruments, in use at that station, may be placed in or removed from any line connected with the station, or by means of which one wire may be connected to another.

The ability to readily connect one wire with another is of use in case of interruption to telegraph lines, in which case a through circuit may be made up of sections of

In the switchboard shown in Fig. 55, the upper left-hand binding-post is connected to earth; the four remaining binding-posts are connected to two separate instruments—the second and third from the top to one instrument, and the fourth and fifth to another instrument. The four posts at the top of the figure are connected to two lines running east and west.

Various connections are made by the insertion of plug keys in the various openings.

Board, Switch, Trunking — —A switchboard in which a few subscribers only are connected with the operator, thus enabling him to obtain any other subscriber by means of trunk wires extending to the other sections. (See *Wire, Trunk*.)

Boat, Electric — —A boat provided with electric motive power.

Electric power has been applied both to ordinary vessels and to submarine torpedo boats.

Boat, Submarine Electric — —A boat capable of being propelled and steered while entirely under water.

The motive power of such boats is generally

electricity. The requisite buoyancy is obtained by means of an air chamber. Artificial ventilation is maintained, the fresh air requisite for breathing being derived from a compressed air cylinder.

Boat, Torpedo — —A boat used for carrying and discharging torpedoes. (See *Torpedo*.)

Bobbin, Electric — —An insulated coil of wire for an electro-magnet.

Body, Charged — —A body containing an electric charge.

Charges are bound or free. (See *Charge, Bound, Charge, Free*.)

Body, Electrified — —A body containing an electric charge.

Body, Human, Resistance of — —The resistance which the human body offers to the passage of an electric current.

The resistance of the human body to the passage of a current varies with the time. The resistance rapidly decreases after a short time.

“The resistance diminishes because of the conduction of water in the epidermis under the action of the constant current and the congestion of the cutaneous blood vessels in consequence of the stimulation.” (*Landois and Stirling*.)

The resistance also varies markedly with the condition of the surface, the condition of the skin, and with the shape, area, position and material of the electrodes by which the current is led into and carried out of the parts. It very seldom is less than 1,000 ohms under the most favorable conditions, and with ordinary contacts is many times that amount.

The muscles offer nearly nine times the resistance in a direction transverse to the fibres than longitudinally to them. (*Hermann*.)

The resistance of the epidermis is greater than that of any other tissue of the body.

The human body probably possesses a true asymmetrical resistance; that is to say, when taken after the current has been passing for some time, its resistance is different in different directions. This variation in the apparent resistance is believed by some to be due to polarization effects.

Body, Insulated — —A body supported on an insulator, or non-conductor of electricity.

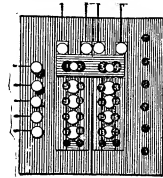

Fig. 55. Telegraphic Switchboard.

Body-Protector, Electric — —A device for protecting the human body against the accidental passage of an electric discharge.

To protect the human body from the accidental passage through it of dangerous electric currents, Delany places a light, flexible, conducting wire, A A B L L, in the position shown in Fig. 56, for the purpose of leading the greater part of the current around instead of through the body. The body-protector thus provides a by-path, or shunt of low resistance, around the body, and protects it from the effects of an accidental discharge. The resistance of the contacts of the protecting conductor with the skin may interfere somewhat with the efficacy of the device. Inside insulating shoe-soles for lessening the danger from accidental contacts through grounded circuits have also been proposed.

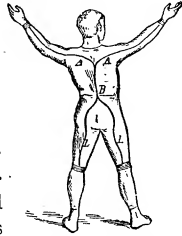

Fig. 56. *Electric Body-Protector.*

Boiler-Feed, Electric — —A device for automatically opening a boiler-feed apparatus electrically when the water in the boiler falls to a certain predetermined point.

Boiling of Secondary or Storage Cell.— (See *Cell, Secondary, or Storage, Boiling of.*)

Bole.—A unit, seldom or never used, proposed by the British Association.

One bole is equal to one gramme-kine. (See *Kine.*)

Bolometer.—An apparatus devised by Langley for measuring small differences of temperature.

A thermal balance. (See *Balance, Thermic.*)

Bombardment, Molecular — —The forcible rectilinear projection from the negative electrode, of the gaseous molecules of the residual atmospheres of exhausted vessels on the passage of electric discharges. (See *Matter, Radiant, or Ultra-Gaseous.*)

Bonsalite.—An insulating substance.

Bore, Armature — —The space provided between the pole pieces of a dynamo or motor for the rotation of the armature.

Boreal Magnetic Pole.—(See *Pole, Magnetic, Boreal.*)

Bot.—A term sometimes used as a contraction for Board of Trade unit of electric supply, or the energy contained in a current of 1,000 ampères flowing in one hour under a pressure of one volt.

The term appears inadmissible. If used at all, it should be B. O. T. The usage of giving the names of distinguished dead electricians to new units is a good one, and should be followed here.

Boucherize.—To subject to the boucherizing process. (See *Boucherizing.*)

Boucherizing.—A process for the preservation of wooden telegraph poles, by injecting a solution of copper sulphate into the pores of the wood. (See *Pole, Telegraphic.*)

Bound Charge.—(See *Charge, Bound.*)

Box Bridge.—(See *Bridge, Box.*)

Box, Cable — —A box placed on a large terminal pole and provided to receive the separate conductors where the air-line wires join a cable.

The wires are distributed in the cable box so as to be readily attached to the air-line wires.

Box, Cooling, of Hydro-Electric Machine.—A box provided in Armstrong's hydro-electric machine for the steam to pass through before leaving the nozzle.

In passing through the cooling-box some of the steam suffers condensation. The cooling-box, therefore, always contains some water, the presence of which seems to be necessary to the operation of the machine.

Box, Distributing, of Conduit.—A name generally applied to a handhole of a conduit. (See *Handhole of Conduit.*)

Box, Distribution, for Arc Light Circuits.—A device by means of which arc and incandescent lights may be simultaneously employed on the same line from a constant-current dynamo-electric machine or other source of constant currents.

A portion of the line circuit, whose difference of potential is sufficient to operate the electro-receptive device, as, for example, an incandescent lamp, is divided into such a number of multiple

circuits as will provide a current of the requisite strength for each of the devices. For example, if the normal current on the line is seven amperes, then each of the seven multiple-connected electro-

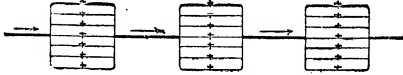

Fig. 57. Series-Multiple Circuit.

receptive devices shown in Fig. 57 will have a current of one ampere passing through it, provided the resistance of each branch is the same.

In order to protect the remaining devices from variations in the current on the extinguishment of any of the devices, automatic cut-outs are provided, which divert the current thus cut off through a resistance equivalent to that of the device.

A variety of distribution boxes are in use. (See *Circuits, Varieties of.*)

Box, District-Call — —A box by means of which an electric signal is automatically sent over a telegraphic line and received by an electro-magnetic device at the other end of the line.

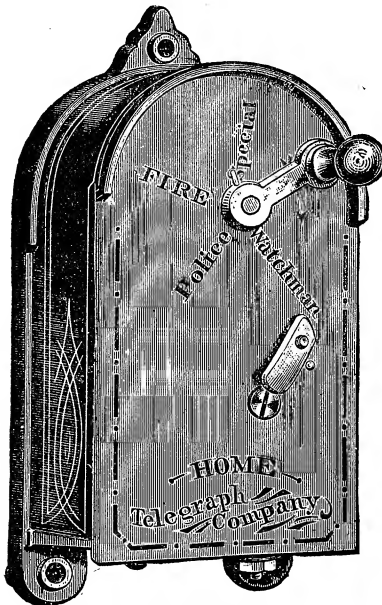

Fig. 58. District Call Box.

A system of district calls includes a number of call boxes connected by telegraphic lines with a central station. A wheel, or its equivalent, set in

motion by the pulling of a lever, makes and breaks an electric circuit and sends over the line a succession of electric impulses of varying length, separated from one another by varying intervals of time. These impulses may be received at the central station as a series of dots and dashes, or may, by means of a Morse sounder, produce successive sounds. By pulling the lever or handle through different distances, different signals may be sent to the central station and serve as calls for various services, such as messenger boys, fire alarm, police, special, etc.

The general appearance of a four-call district box is shown in Fig. 58. In order to transmit a call for any particular one of these four services the handle is pulled until it comes opposite to the letters indicating the required service, and is then released. The service required is then indicated at the receiving, or central station, through the varying signals sent over the line by the movement of the break-wheel, on the release of the handle.

Box, Fire-Alarm Signal — —A signal box provided for the purpose of automatically sending an alarm of fire.

The fire-alarm box shown in Fig. 59, operates

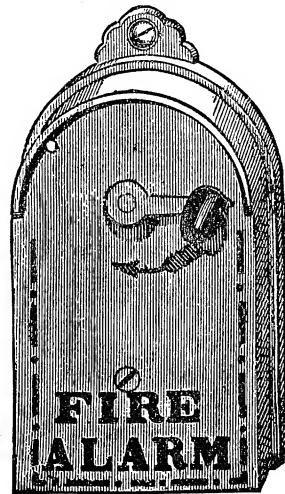

Fig. 59. Fire-Alarm Signal-Box.

on the same principle as the district call box. The movement of the handle in the direction of the arrow drives a wheel that makes and breaks a circuit at certain intervals.

The fire-alarm signal boxes are connected

either with a central station, or with the engine houses of the district in which the alarm is sounded, or with both.

Box, Fire-Alarm Telegraph — — An automatic-call signal-box employed for sending an alarm of fire to a central station.

A form of fire-alarm telegraph box is shown in Fig. 60. It consists essentially of a circuit-breaker

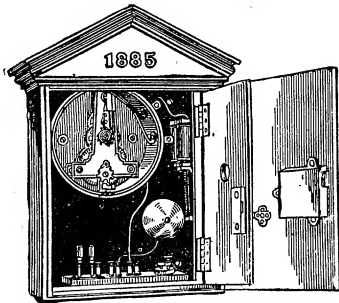

Fig. 60. Fire-Alarm Telegraph Box.

that is moved by pulling down a lever. The release of the lever repeats the signal to the fire department at the central station a certain number of times. The box also contains a relay bell, lightning arrester and signal-bell key.

Box, Fishing — — A term sometimes used instead of junction box. (See *Box, Function*.)

Box, Flush — — A box or space, flush with the surface of a road-bed, provided in a system of underground wires or conduits, to facilitate the introduction of the conductors into the conduit, or for the examination of the conductors.

Box, Fuse — — The box in which the fuse-wire of a safety-fuse is placed.

The fuse-box should be formed of moisture-proof, incombustible, insulating materials.

Box, Junction — — A moisture-proof box provided in a system of underground con-

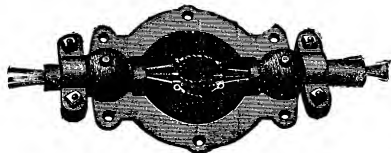

Fig. 61. Junction Box.

ductors to receive the terminals of the feeders, in which connection is made between

the feeders and the mains, and from which the current is distributed to the individual consumer. (See *Feeder, Main, Electric*.)

A form of junction box for coupling lengths of conductors is shown in Fig. 61.

Box, Patrol Alarm — — An automatic-signal call-box provided for use on the outside of buildings.

The call-box is placed inside a box, the outer door of which is furnished with a Yale lock.

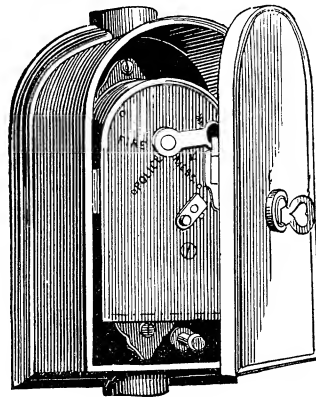

Fig. 62. Patrol Box.

A form of patrol box is shown in Fig. 62.

Box, Resistance — — A box containing a number of separate coils of known resistances employed for determining the value of an unknown resistance, and for other purposes. (See *Bridge, Electric, Box Form of*.)

Box-Sounding Relay. — (See *Relay, Box-Sounding*.)

Box-Sounding Telegraphic Relay. — (See *Relay, Box-Sounding Telegraphic*.)

Box, Splice — — A box provided for holding splice joints and loops, and so arranged as to be readily accessible for examination, re-arranging, cross-connecting, etc.

Splice-boxes vary in shape and construction according to the purposes for which they are designed.

Box, Splice, Four-way — — A splice-box provided with four ways or tubular conduits.

Box, Splice, Two-Way — — A splice-

box provided with but two tubular conduits or ways.

Box, Tumbling — —A rotating box in which metallic articles that are to be electroplated are placed so as to be polished by attrition against one another.

Boxing the Compass.—(See *Compass, Boxing the.*)

Bracket, Lamp, Electric — —A device similar to a bracket for a gas burner for holding or supporting an electric lamp.

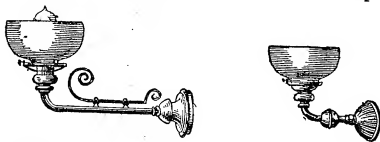

Fig. 63. Lamp Bracket. Fig. 64. Lamp Bracket.

Lamp brackets are either fixed or movable.

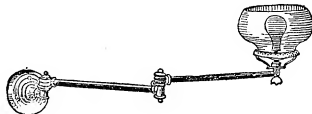

Fig. 65. Lamp Bracket, Movable Arms.

Those shown in Figs. 63 and 64 are fixed. That shown in Fig. 65 is movable.

Bracket, Telegraphic — —A support or cross piece placed on a telegraph pole for the support of the insulators of telegraphic lines.

Telegraphic insulators are supported either on wooden *arms*, or on iron or metal *brackets*.

Fig. 66 shows a form of iron bracket. Fig. 67 shows a form of wooden arm.

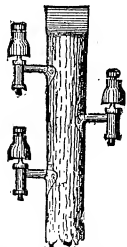

Fig. 66. Telegraphic Bracket.

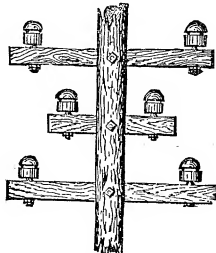

Fig. 67. Telegraphic Cross-Arm.

Various well known modifications of these shapes are in common use. (For details, see *Fole, Telegraphic.*)

Braid, Tubular — —A braid of fibrous insulating material, woven in the form of a tube, and provided for drawing over a splice after two wires have been connected.

Braided Wire.—(See *Wire, Braided.*)

Brake, Electro-Magnetic — —A brake for car wheels, the braking power for which is either derived entirely from electro-magnetism, or is thrown into action by electro-magnetic devices.

Electro-magnetic car brakes are of a great variety of forms. They may, however, be arranged in two classes, viz.:

(1.) Those in which magnetic adhesion, or the magnetic attraction of the brake to the wheels, is employed.

(2.) Ordinary brake mechanism in which the force operating the brake is thrown into action by an electro-magnet.

Brake, Friction — —A name sometimes given to a Prony brake. (See *Brake, Prony.*)

Brake, Magneto-Electric — —A device for checking the swing of a galvanometer, in which a slight inverse current is sent through the coils of the galvanometer.

The Frey magneto-electric brake, as shown in Fig. 68, consists of a small coil, connected by a

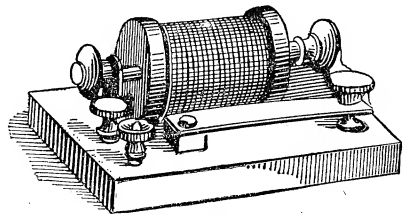

Fig. 68. Electric Brake.

contact-key with the galvanometer terminals. A small adjustable magnet coil is provided for regulating the action of the inverse current. To avoid disturbance, the brake is placed at least 4 or 5 feet from the galvanometer. Manipulation of the ordinary galvanometer key attains the same end in a much simpler manner.

Brake, Prony — —A mechanical device for measuring the power of a driving shaft.

An inflexible beam, Fig. 69, is provided at one end with a clamping device for clamping the driving shaft or pulley, and at the other end A, with a pan for holding weights.

If the brake be arranged as shown in Fig. 69, and the shaft rotate in the direction of the arrow, the tendency will be to carry the beam around with the shaft, placing it at some given moment

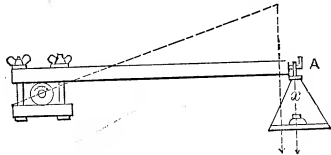

Fig. 69. Prony Brake.

in the position shown by the dotted line. If a sufficiently heavy weight be placed at x, in a pan hung at A, the beam will assume a position vertically downwards. If, however, the torque, or

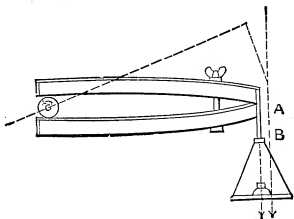

Fig. 70. Prony Brake.

twisting force of the driving shaft, be balanced by the weight, the bar will remain horizontal. The power can then be calculated by multiplying the weight in pounds by the circumference in feet of the circle of which the bar is a radius, and this product by the number of turns of the driving shaft per minute. The product will be the num-

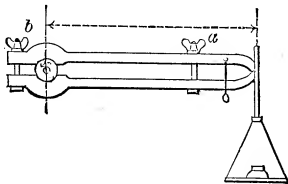

Fig. 71. Prony Brake.

ber of foot-pounds per minute, and, when divided by 33,000, will give the *horse-power*.

Some modified forms of the Prony brake are shown in Figs. 70 and 71.

A simple form of brake consists of a cord passed over the pulley of the machine to be tested. A weight is hung at one end of the cord. The other

end of the cord is attached to the top of a spring balance, the other end of which is fastened to the floor. A reading of the spring balance is taken while the pulley is at rest and when it is in motion, and the result calculated.

Branch.—A term applied to any principal distributing conductor from which outlets are taken or taps made.

Branch-Block.—(See *Block, Branch*.)

Branch Conductors.—(See *Conductor, Branch*.)

Branch Fuse.—(See *Fuse, Branch*.)

Branch, Sub — —A distributing conductor taken from a branch.

Branding, Electric — —A process whereby the branding tool is heated by electrical incandescence instead of by ordinary heat.

The branding tool consists essentially of a small transformer with devices for regulating the current strength by switches and choking coils.

Brassing, Electro — —Coating a surface with a layer of brass by electro-plating. (See *Plating, Electro*.)

The plating bath contains a solution of copper and zinc; a brass plate is used as an anode.

Break.—A want of continuity in a circuit.

Break, Circuit Loop — —A device for introducing a loop in any part of a line circuit.

A form of circuit loop-break is shown in Fig. 72.

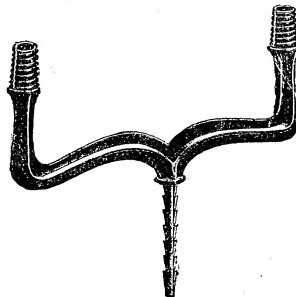

Fig. 72. Circuit Loop Break.

It consists essentially of a rigid frame with two porcelain or other suitable insulators for the support of the loop wires.

Break-Down Switch.—(See *Switch, Break-Down*.)

Break-Induced Current.—(See *Current, Break-Induced*.)

Break, Mercury — —A form of circuit breaker operated by the removal of a conductor from a mercury surface.

Mercury breaks assume a variety of forms. One end of the circuit is connected with the mercury, and the other with the conductor.

Break Shock.—(See *Shock, Break*.)

Breaker, Circuit — —Any device for breaking a circuit.

Breaking the Primary.—(See *Primary, Breaking the*.)

Breaking Weight of Telegraph Wires.—(See *Wires, Telegraph, Breaking Weight of*.)

Breath Figures.—(See *Figures, Breath*.)

Breeze, Electric — —A term sometimes employed in electro-therapeutics for a brush discharge.

One of the electrodes, consisting of a single point or a number of points, is held near the parts to be treated so that the convective discharge is received thereon. The other electrode is connected to the body of the patient.

Breeze, Electro-Therapeutic — —An electric breeze. (See *Breeze, Electric*.)

Breeze, Head, Electro-Therapeutic — —A form of electric convective discharge, or electric breeze, applied to the head. (See *Breeze, Electric*.)

Breeze, Static — —An electric breeze obtained by the convective discharge of an electrostatic charge.

Bridge-Arms.—(See *Arms, Bridge or Balance*.)

Bridge, Box — —A box of resistance coils so arranged as to be capable of being used directly as a Wheatstone electric balance. (See *Bridge, Electric, Box Form of*.)

The commercial form of Wheatstone's balance.

Bridge, Electric — —A device for measuring the value of electric resistances.

The electric bridge is also called the Electric Balance.

This is called a bridge because the wire M, G, N, bridges or joins points of equal potential.

A, B, C and D, Fig. 73, are four electric resistances, any one of which can be determined in *ohms*, provided the absolute value of one of the others, and the relative values of any two of the remaining three are known in *ohms*.

A voltaic battery, Zn C, is connected at Q and P, so as to branch at P, and again unite at

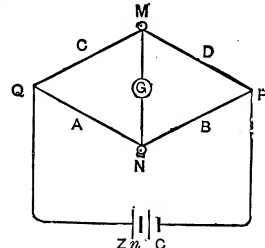

Fig. 73. *Electric Balance.*

Q, after passing through the conductor D C, and B A.

A sensitive galvanometer, G, is connected at M N, as shown.

The passage of a current through any resistance is attended by a fall of potential proportional to the resistance. (See *Potential, Electric*.) If, then, the resistances A, C and B, are so proportioned to the value of the unknown resistance D, that no current passes through the galvanometer G, the two points, M and N, in the two circuits, Q M P and Q N P, are at the same potential. That is to say, the fall of potential along Q M P and Q N P, at the points M and N, is equal. Since the fall of potential is proportional to the resistance, it follows that

$$\begin{aligned} A : B &:: C : D, \\ \text{or } A \times D &= B \times C, \\ \text{or } D &= \left(\frac{B}{A}\right) C. \end{aligned}$$

If then we know the values of A, B and C, the value of D, can be readily calculated.

By making the value $\frac{B}{A}$, some simple ratio, the value of D, is easily obtained in terms of C.

The resistances A, B and C, may consist of coils of wire whose resistance is known. To avoid their magnetism affecting the galvanometer needle during the passage of the current through them, they should be made of wire bent into two

parallel wires and wrapped in coils called *resistance coils*; or a *resistance box* may be used. (See *Coil, Resistance. Box, Resistance.*)

There are two general forms of Wheatstone's Bridge, the box form, and the sliding form.

Bridge, Electric, Arms of — — The resistances of an electric bridge or balance. (See *Bridge, Electric.*)

Bridge, Electric, Box Form of — — A commercial form of bridge or balance in which all the known arms or branches of the bridge, except the unknown arm, consist of standardized resistance coils, whose values are given in ohms. (See *Coil, Resistance.*)

The box form of bridge or balance is shown in

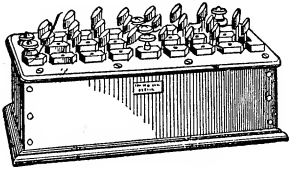

Fig. 74. Box Balance.

perspective in Fig. 74, and in plan in Fig. 75. The bridge arms, corresponding to the resistances

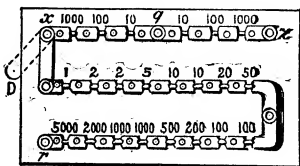

Fig. 75. Box Balance.

A and B, of Fig. 73, consist of resistance coils of 10, 100 and 1,000 ohms each, inserted in the arms qz , and qx , of Fig. 75. These are called the *proportional coils*. The arm corresponding to resistance C, of Fig. 73, is composed of separate resistances of 1, 2, 2, 5, 10, 10, 20, 50, 100, 100, 200, 500, 1,000, 1,000, 2,000 and 5,000 ohms. In some forms of box bridges additional decimal resistances are added.

The resistance coils are wound, as shown in Fig. 76, after the wire has been bent on itself in the middle. This is done in order to avoid the effects of induction, among which are a disturbing action on a galvanometer used near them, and the introduction of a spurious resistance in the coils themselves. (See *Resistance, Spurious.*)

To avoid the effects of changes of resistance occasioned by changes of temperature, the coils are made of German silver, or, preferably, of alloys called *Platinoid* or *Platinum silver*. Even when these alloys are used, care should be taken not to allow the currents to pass continuously through the resistance coils longer than a few moments.

The coils, C, C', are connected with one another in series by soldering their ends to the short

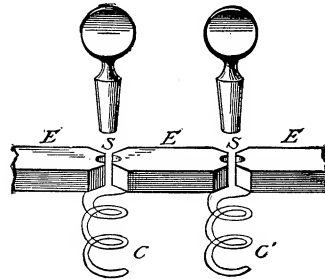

Fig. 76. Resistance Coils.

thick pieces of brass, E, E, E, Fig. 76. On the insertion of the plug-keys, at S, S, the coils are cut out by short-circuiting. Care should be taken to see that the plug-keys are firmly inserted and free from grease or dirt, as otherwise the coil will not be completely cut out. As each plug-key is inserted it should be turned slightly in the opening, so as to insure good contact.

The following are the connections, viz.: The galvanometer is inserted between q and r , Fig. 77,

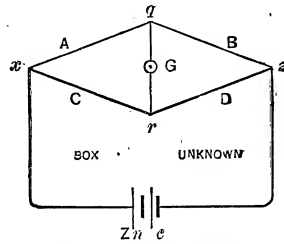

Fig. 77. Electric Balance.

the unknown resistance between z and r ; the battery is connected to x and z . A convenient proportion being taken for the value of the proportional coils, resistances are inserted in the arm C, until no deflection is shown by the galvanometer G. The similarity between these connections and those shown in Fig. 75 will be seen from an inspection of Fig. 77. The arms, A and B, correspond to qx and qz , of Fig. 75; C, to the arm

$\times r$, Fig. 75; and D, to the unknown resistance. We then have as before:

$$A:B::C:D, \text{ or } A \times D = B \times C. \therefore D = \left(\frac{B}{A}\right) C.$$

The advantage of the simplicity of the ratios, A and B, or 10, 100 and 1,000 of the bridge box, will therefore be manifest. The battery terminals may also be connected to q and r , and the galvanometer terminals to x and z , without disturbing the proportions.

Bridge, Electric, Commercial Form of — — A name sometimes given to the box form of Wheatstone's electric balance. (See *Bridge, Electric, Box Form of*.)

Bridge, Electric Duplex — — An arrangement of telegraphic circuits in the form of a Wheatstone electric bridge for the purposes of duplex telegraphy. (See *Telegraphy, Duplex, Bridge Method of*.)

Bridge, Electric, Proportionate Arms of — — (See *Arms, Proportionate*.)

Bridge, Electric, Slide-Form of — — A balance in which the proportionate arms of the bridge are formed of a single thin wire, of uniform diameter, generally of German silver, of comparatively high resistance. The length of this wire is usually one metre; hence this apparatus is often called the metre bridge.

A *Sliding Contact Key* slides over the wire; one terminal of the key is connected with the galvanometer and the other with the wire when the key is depressed. As the wire is of uniform diameter the resistances of the arms, A and B, Fig. 78, will

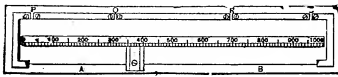

Fig. 78. Slide Bridge.

be directly proportional to the lengths. A scale placed near the wire serves to measure these lengths. A thick metal strip connected with the slide wire has four gaps at P, Q, R and S.

When in ordinary use, the gaps at P and S, are either connected by stout strips of conducting material or by known resistances, in which latter case they act simply as ungraduated extensions of the slide wire, and, like lengthening the slide wire, increase the sensibility of the instrument.

The unknown resistance is then inserted in the gap at Q, and a known resistance, generally the *resistance box*, in that at R. The galvanometer has one of its terminals connected to the metal strip between Q and R, and its other terminal to the sliding key. The battery terminals are connected to the metal strips between P and Q, and R and S, respectively.

These connections are more clearly seen in the form of bridge shown in Fig. 79. The slide wire, w w, consists of three separate wires each a metre

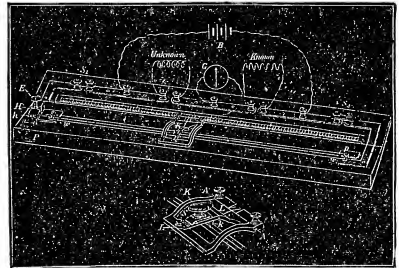

Fig. 79. Slide Form of Bridge.

in length, so arranged that only one wire, or two in series, or all three in series, can be used. Matters being now arranged as shown, the sliding key is moved until no current passes through the galvanometer when the key is depressed.

The slide form of bridge is not entirely satisfactory, since the uncertainty of the spring-contact causes a lack of correspondence between the point of contact and the point of the scale on which the index rests.

The loss of uniformity in the diameter of the wire, due to constant use, causes a lack of correspondence between the resistance of the wire and its length. With care, however, very accurate results can be obtained by the slide form.

Bridge, Inductance — — An apparatus for measuring the inductance of a circuit similar to a Wheatstone bridge. (See *Inductance*.)

Professor Hughes employed an inductance bridge of the following description:

Four resistances, Q, S, R and P, arranged as shown in Fig. 80, form the bridge. The resistances, Q, S and R, consist of sections of German silver wire, one metre in length, each of the resistance of 4 ohms. P, is a coil of wire possessing sensible inductance. The object of the

bridge is to measure the value of this inductance. I, is an interrupter placed in the circuit of the battery B.

Suppose the interrupter, I, be placed in the telephone circuit between T and c. By shifting the sliding contact so as to alter the value of R, a bal-

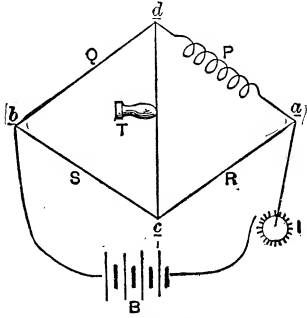

Fig. 80. Inductance Bridge.

ance can be effected and silence obtained in the telephone.

Now remove the interrupter and place it in the battery circuit between b and a, as shown in Fig. 80. If now, the interrupter, I, be made to rapidly interrupt the battery current, this balance is destroyed, and cannot be again obtained by any variation in the value of the resistance, R.

The reason of this is evident. On the closing or opening of the battery current, the inductance of P, produces a counter electromotive force in P, which produces differences of potential between a and c. If an attempt be made to prevent this,

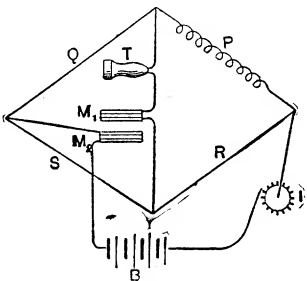

Fig. 81. Hughes' Inductance Bridge.

by altering the value of R, the steady balance is destroyed, and the telephone will be traversed by a current during the time the currents have become steady. In order to obtain a balance during rapid alternations of the battery current, Professor Hughes placed a pair of mutually in-

ductive coils in the battery and the telephone circuits, as shown in Fig. 81.

The resistances, Q, S, R and P, are the same as already described. The mutually inductive coils, M_1 and M_2 , are placed respectively in the telephone and battery circuits in the manner shown. The coil M_2 , in the battery circuit is fixed, while that in the telephone circuit is so arranged that it can be maintained, with its centre coincident with that of M_2 , while its axis can be placed at any desired angle with M_2 . When the axes of the coils are at right angles, the inductance is zero. When they are co-linear, the inductance is at its maximum.

When the coils M_1 , and M_2 , are in any intermediate position, the inductive electromotive force produced in the telephone circuit can, if the value of R, be changed, be made to balance the impulsive electromotive force due to the inductance of P, and the value of this latter can, therefore, be inferred.

Bridge, Magnetic — — An apparatus invented by Edison for measuring magnetic resistance, similar in principle to Wheatstone's electric bridge.

The magnetic bridge is based on the fact that two points at the same magnetic potential, when connected, fail to produce any action on a magnetic needle. The magnetic bridge consists, as shown in Fig. 82, of four arms or sides made of

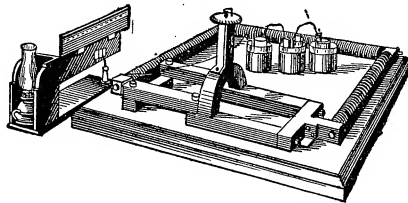

Fig. 82. Magnetic Bridge.

pure, soft iron. The poles of an electro-magnet are connected to projections at the middle of the short side of the rectangle. By this means a difference of magnetic potential is maintained at these points. The two long sides are formed of two halves each, which form the four arms of the balance. Two of these only are movable.

Two curved bars of soft iron, of the same area of cross-section as the arms of the bridge, rest on the middle of the long arms, in the arched shape shown. Their ends approach near the top of the

arch within about a half inch. A space is hollowed out between these ends, for the reception of a short needle of well-magnetized hardened steel, suspended by a wire from a torsion head.

The movements of the needle are measured on a scale by a spot of light reflected from a mirror.

The electro-magnet maintains a constant difference of magnetic potential at the two shorter ends of the rectangle. If, therefore, the four bars, or arms of the bridge, are magnetically identical, there will be no deflection, since no difference of potential will exist at the ends of the bars between which the needle is suspended. If, however, one of the bars or arms be moved even a trifle, the needle is at once deflected, the motion becoming a maximum when the bar is entirely removed. If replaced by another bar, differing in cross-section, constitution, or molecular structure, the balance is likewise disturbed.

The magnetic bridge is very sensitive. It was designed by its inventor for testing the magnetic qualities of the iron used in the construction of dynamo-electric machines.

Bridge Method of Duplex Telegraphy.—(See *Telegraphy, Duplex, Bridge Method of.*)

Bridge Method of Quadruplex Telegraphy.—(See *Telegraphy, Quadruplex, Bridge Method of.*)

Bridge, Metre — —A slide form of Wheatstone's electric bridge, in which the slide wire is one metre in length. (See *Bridge, Electric, Slide Form of.*)

Bridge, Resistance — —A term sometimes applied to an electric bridge or balance. (See *Bridge, Electric.*)

Bridge, Reversible — —A bridge or balance so arranged that the proportionate coils can be readily interchanged, thus permitting the bridge coils to be readily tested by reversing.

Bridge, Wheatstone's Electric — —A name given to the electric bridge or balance. (See *Bridge, Electric.*)

Bridges.—Heavy copper wires suitably shaped for connecting the dynamo-electric machines in an incandescent light station to the bus-rods or wires.

Bright Dipping.—(See *Dipping, Bright.*)

Bright Dipping Liquid.—(See *Liquid, Bright Dipping.*)

Britannia Joint.—(See *Joint, Britannia.*)

Broken Circuit.—(See *Circuit, Broken.*)

Bronzing, Electro — —Coating a surface with a layer of bronze by electro-plating. (See *Plating, Electro.*)

The plating bath contains a solution of tin and copper.

Brush-and-Spray Discharge.—(See *Discharge, Brush-and-Spray.*)

Brush Discharge.—(See *Discharge, Brush.*)

Brush Electrode.—(See *Electrode, Brush.*)

Brush, Faradic — —An electrode in the form of a brush employed in the medical application of electricity.

The bristles are generally made of nickellized copper wire.

Brush-Holders for Dynamo-Electric Machines.—Devices for supporting the collecting brushes of dynamo-electric machines.

As the brushes require to be set or placed on the commutator in a position which often varies with the speed of the machine, and with changes in the resistance of the external circuit, all brush-holders are provided with some device for moving them concentrically with the commutator cylinder.

Brush Rocker.—(See *Rocker, Brush.*)

Brush, Scratch — —A brush made of wire or stiff bristles, etc., suitable for cleaning the surfaces of metallic objects before placing them in the plating bath.

Scratch brushes are made of various shapes and are provided with wires or bristles of varying coarseness.

Some forms of scratch and finishing brushes are shown in Fig. 83. They are circular in outline

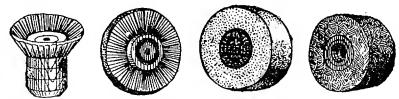

Fig. 83. Scratch Brushes.

and are adapted for use in connection with a lathe.

Brush, Scratch, Circular — —A scratch brush of a circular shape, so fitted as to be capable of being placed in a lathe and set in rapid rotation.

Brush, Scratch, Hand — —A scratch brush operated by hand, as distinguished from a circular scratch brush operated by a lathe.

Brushes, Adjustment of Dynamo-Electric Machines — —Shifting the brushes into the required position on the commutator cylinder, either non-automatically by hand, or automatically by the current itself. (See *Regulation, Automatic, of Dynamo-Electric Machines.*)

Brushes, Carbon, for Electric Motors — —Plates of carbon for leading current to electric motors. (See *Brushes of Dynamo-Electric Machine.*)

These are generally known simply as brushes.

Brushes, Collecting, of Dynamo-Electric Machine — —Conducting brushes which bear on the commutator cylinder, and take off the current generated by the difference of potential in the armature coils. (See *Brushes, of Dynamo-Electric Machine.*)

Brushes, Lead of — —The angle through which the brushes of a dynamo-electric machine must be moved forward, or in the direction of rotation, in order to diminish sparking and to get the best output from the dynamo.

The necessity for the lead arises from the counter magnetism or magnetic reaction of the armature, and the magnetic lag of its iron core. (See *Lead, Angle of.*)

The position of the brushes on the commutator to insure the best output is practically the same in a series dynamo for any current strength. In shunt and compound dynamos it varies with the lead.

Brushes of Dynamo-Electric Machine. — Strips of metal, bundles of wire, slit plates of metal, or plates of carbon, that bear on the commutator cylinder of a dynamo-electric machine, and carry off the current generated.

Rotary brushes consisting of metal discs are sometimes employed. Copper is almost univer-

sally used for the brushes of dynamo-electric machines. Carbon brushes are often used for dynamo-electric motors.

The brush shown at B, Fig. 84, is formed of copper wires, soldered together at the non-bearing end. A copper plate, slit at the bearing end, is shown at C, and bundles of copper plates, soldered together at the non-bearing end, are shown at D.

The brushes should bear against the commutator cylinder with sufficient force to prevent jumping, and consequent burning, and yet not so hard as to cause excessive wear.

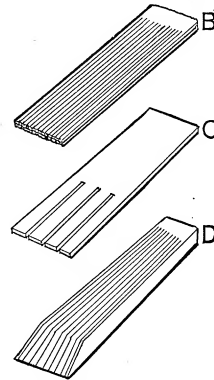

Fig. 84. Brushes.

Brushes, Rotating, of Dynamo-Electric Machines — —Discs of metal, employed in place of the ordinary brushes for carrying off the current from the armatures of dynamo-electric machines.

Brushing, Scratch — —Cleansing the surface of an article to be electroplated, by friction with a scratch brush.

Scratch brushing is generally done with the brushes wet by various solutions.

Buckling.—Irregularities in the shape of the surfaces of the plates of storage cells, following a too rapid discharge.

Bug.—A term originally employed in quadruplex telegraphy to designate any fault in the operation of the apparatus.

This term is now employed, to a limited extent, for faults in the operation of any electric apparatus.

Bug-Trap.—A device employed to overcome the "bug" in quadruplex telegraphy.

Bulb, Lamp — —The chamber or globe in which the filament of an incandescent electric lamp is placed.

The chamber or globe of a lamp must be of such construction as to enable the high vacuum necessary to the operation of the lamp to be maintained.

Bunched Cable.—(See *Cable, Bunched*.)

Bunched Cable, Straightaway — —
(See *Cable, Bunched, Straightaway*.)

Bunched Cable, Twisted — — (See
Cable, Bunched, Twisted.)

Bunsen Voltaic Cell.—(See *Cell, Voltaic, Bunsen's*.)

Buoy, Electric — — A buoy on which luminous electric signals are displayed.

Burglar Alarm.—(See *Alarm, Burglar*.)

Burglar Alarm Annunciator.—(See *Annunciator, Burglar Alarm*.)

Burglar Alarm Contacts.—(See *Contacts, Burglar Alarm*.)

Burglar Alarm, Yale Lock Switch for —
(See *Alarm, Yale-Lock-Switch Burglar*.)

Burner, Argand Electric — — An argand gas-burner that is lighted by means of an electric spark.

The argand electric burner assumes a variety of forms, such as the *plain pendant*, the *ratchet-pendant* and the *automatic*. They are also used in systems of multiple gas lighting.

Burner, Argand Electric, Automatic — — An argand burner arranged for automatic electric lighting. (See *Burner, Automatic-Electric*.)

Burner, Argand Electric, Hand-Lighter — — A plain-pendant electric burner adapted for lighting an argand gas-burner. (See *Burner, Plain-Pendant Electric*.)

Burner, Argand-Electric, Plain-Pendant — — A plain-pendant electric burner adapted for lighting an argand gas burner. (See *Burner, Plain-Pendant Electric*.)

Burner, Argand-Electric, Ratchet-Pendant — — A ratchet-pendant electric burner adapted for lighting an argand gas-burner. (See *Burner, Ratchet-Pendant Electric*.)

Burner, Automatic-Electric — — An electric device for both turning on the gas and lighting it, and turning it off, by alternately touching different buttons.

The gas-cock is opened or closed by the motion of an armature, the movements of which are controlled by two separate electro-magnets. One push-button, usually a white one, turns the gas on

by energizing one of the electro-magnets and, at the same time, lights it by means of a succession of sparks from a spark coil. Another push-button, usually a black one, turns the gas off by energizing the other electro-magnet. The turning on or off of the gas is accomplished by positive motions. Automatic burners are also made with a single button.

An Argand Electric Burner is shown in Fig. 85.

Burner, Electric Candle — — A device for electrically lighting a gas jet in a burner surrounded by a porcelain tube in imitation of a candle.

Electric candle burners are either simple or ratchet candle burners.

Burner, Hand-Lighting Electric

— — A name sometimes applied to a plain-pendant electric burner. (See *Burner, Plain-Pendant Electric*.)

Burner, Jump-Spark — — A term sometimes applied to a gas burner in which the issuing gas is ignited by a spark that jumps between the metallic points placed on it.

Jump-spark burners are used in systems of multiple gas lighting. (See *Lighting, Electric Gas*.)

Burner, Plain-Pendant Electric — — A gas-burner provided with a pendant for the purpose of lighting the gas by means of a spark, after the gas has been turned on by hand.

The gas is first turned on by hand at the ordi-

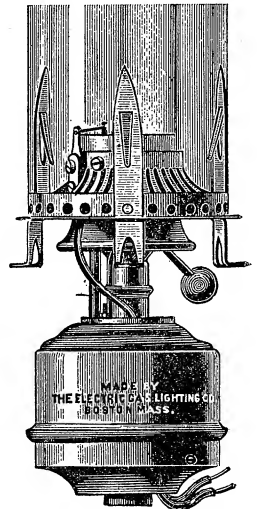

Fig. 85. Argand Electric Burner.

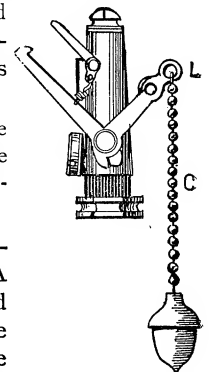

Fig. 86. Plain-Pendant Burner.

nary key, and is then lighted by pulling the pendant C, Fig. 86. A spark from a spark coil ignites the gas.

This is sometimes called an *electric hand-lighting burner*.

Burner, Ratchet-Pendant Candle Electric — — A burner for both lighting and extinguishing a candle gas jet.

Burner, Ratchet-Pendant Electric — — A gas-burner in which one pulling of a pendant turns on the gas and ignites it by means of an electric spark from a spark coil, and the next pulling of the pendant turns off the gas.

A ratchet-wheel and pawl are operated by the motion of the pendant. The first pull of the pendant chain moves the ratchet so as to open a four-way gas cock, and at the same time light the gas at the burner tip by a *wipe-spark* from a spark coil. On the next pull of the pendant, the four-way cock is turned so as to turn off the gas. Alternate pulls, therefore, light and extinguish the gas.

Burner, Simple Candle Electric — — A plain-pendant electric burner. (See *Burner, Plain Pendant Electric*.)

Burner, Thumb-Cock Electric — — An electric gas-burner, in which the turning of an ordinary thumb-cock turns on the gas, and ignites it by a spark produced by a wiping contact actuated by the motions of the thumb-cock.

A form of thumb-cock burner is shown in Fig. 87.

Burner, Vibrating - Electric — — An

electric gas-burner in which the gas is lighted after it is turned on by hand, by means of the spark from a spark coil produced on the rapid

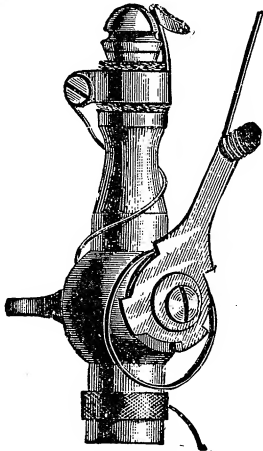

Fig. 87. Thumb-Cock Burner.

making and breaking of the circuit by a vibrating contact.

The vibrating-electric burner has a single electro-magnet. It is operated by means of a button or switch, and may be used on single lights or on groups of lights. It bears the same relation to the automatic burner that the plain-pendant burner does to the ratchet burner.

Burnetize.—To subject to the Burnetizing process. (See *Burnetizing*.)

Burnetizing.—A method adopted for the preservation of wooden telegraph poles by injecting a solution of zinc chloride into the pores of the wood. (See *Pole, Telegraphic*.)

Burning at Commutator of Dynamo.—An arcing at the brushes of a dynamo-electric machine, due to their imperfect contact, or improper position, which results in loss of energy and destruction of the commutator segments.

Bus.—A word generally used instead of omnibus. (See *Omnibus*.)

Bus-Bars.—(See *Bars, Bus*.)

Bus-Rod Wires.—(See *Wires Bus-Rod*.)

Bus-Wire.—(See *Wire, Bus*.)

Butt Joint.—(See *Joint, Butt*.)

Button, Carbon — — A resistance of carbon in the form of a button.

A button of carbon is used as an electric resistance in a variety of apparatus; its principal use, however, is in the transmitting instrument of the electric telephone. In the telephone transmitter, the button is so placed between contact-plates that when the plates are pressed together by the sound-waves, the electrical resistance is decreased by a decrease in the thickness of the carbon button, an increase in its density, and an increase in the number of points where the carbon touches the plates. Rheostats, or resistances, have been made by the use of a number of carbon buttons or discs piled one on another and placed in a glass tube. Discs of carbonized cloth form excellent resistances for such purposes.

Button, Press — — A push button. (See *Button, Push*.)

Button, Push — — A device for closing

an electric circuit by the movement of a button.

A button, when pushed by the hand, closes the

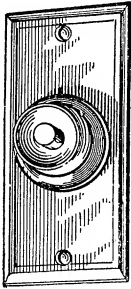

Fig. 88. Push Button.

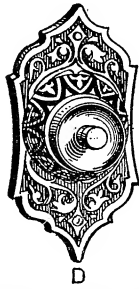

Fig. 89. Push Button.

contact, and thus completes a circuit in which some electro-receptive device is placed. This circuit is opened by a spring, on the removal of the pressure. Some forms of push-buttons are shown in Figs. 88, 89 and 90.

A floor-push for dining-rooms and offices is shown in Fig. 90.

Fig. 88 shows the general appearance of an ordinary bell-push. The arrangement of the interior spring contacts will be understood by an inspection of Fig. 91.

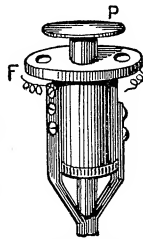

Fig. 90. Floor Push.

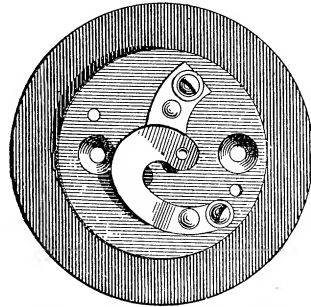

Fig. 91. Spring Contact of Bell Push.

automatic make-and-break. (See *Make-and-Break, Automatic.*)

The buzzer is generally placed inside a resonant

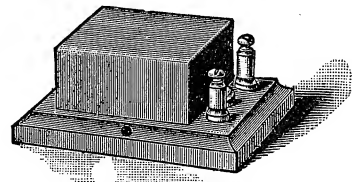

Fig. 92. Buzzer.

case of wood in order to strengthen the sound by resonance. A form of buzzer is shown in Fig. 92.

C

C.—An abbreviation for centigrade.

Thus, 20 degrees C. means 20 degrees of the centigrade thermometric scale. (See *Scale, Centigrade Thermometer.*)

C.—A contraction for current.

Generally a contraction for the current in ampères, as $C = \frac{E}{R}$.

C. C.—A contraction for cubic centimetre. (See *Weights and Measures, Metric System of.*)

C. G. S. Units.—A contraction for centimetre-gramme-second units. (See *Units, Centimetre-Gramme-Second.*)

C. P.—A contraction for candle power. (See *Candle, Standard.*)

Cable.—An electric cable. (See *Cable, Electric.*)

Cable.—To send a telegraphic dispatch, by means of a cable.

Cable, Aerial — —A cable suspended in the air from suitable poles.

Cable, Anti-Induction, Waring — — A form of anti-induction cable.

In the Waring anti-induction cable the separate conductors are covered with a fibrous insulator, from which all air and moisture is expelled, and the fibre then saturated with an insulating ma-

terial called ozite. The conductors are then protected from the inductive effects of neighboring conductors by a continuous sheath of lead alloyed with tin.

Where the cables are bunched, the bunches are sometimes again surrounded by insulating material, and the whole then covered by a continuous lead sheathing; generally, however, the separately insulated conductors are bunched, and then covered by a single sheathing of lead alloyed with tin.

Cable, Armature of — — The armor of a cable. (See *Armature of a Cable*.)

Cable, Armor of — — The protecting sheathing or metallic covering on the outside of a submarine or other electric cable.

Cable, Armored — — An electric cable provided, in addition to its insulating coating, with a protective coating or sheathing, generally of metal tubing or wire.

Cable-Box.—(See *Box, Cable*.)

Cable, Bunched — — A cable containing more than a single wire or conductor.

Some forms of bunched, lead-covered cables, are shown in Fig. 93.

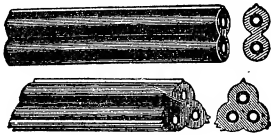

Fig. 93. Bunched Cables.

Cable, Bunched, Straightaway — —

A bunched cable the separate conductors of which extend in the direction of the length of the cable without any twisting, being placed in successive layers.

In arranging the separate conductors in successive layers an advantage is gained in testing for a given wire in order to make a loop, splice, or branch with the next adjoining section. This is rendered still easier by giving the conductors of the successive layers some distinctive form of braiding in the fibrous insulating material, or some distinctive color.

Cable, Bunched, Twisted — — A bunched cable, the separate conductors of which are twisted-pairs placed in successive layers.

Each twisted-pair of a bunched cable acts as a metallic circuit, and, moreover, possesses the advantage of avoiding the ill effects of induction, so disadvantageous in telephone circuits.

In laying up the twisted-pairs in successive layers in a bunched cable, the direction of twisting is reversed in each successive layer. This form is especially desirable on all long cable lines.

In the case of twisted cables for telephone lines, the twists are sometimes made as frequent as one in every three or four inches. In such cases the cross-talk of induction is inappreciable.

Cable, Capacity of — — The quantity of electricity required to raise a given length of a cable to a given potential, divided by the potential.

The amount of charge for a given potential that any single conductor will take up with the rest of the conductors grounded. (See *Capacity, Electrostatic*.)

The ability of a wire or cable to permit a certain quantity of electricity to be passed into it before acquiring a given difference of potential.

Before a telegraph line or cable can transmit a signal to its further end, its difference of potential must be raised to a definite amount dependent on the character of the instruments and the nature of the system.

The first effect of electricity being passed into a line is to produce an accumulation of electricity on the line, similar to the charge in a condenser. Cables especially act as condensers, and from the high specific inductive capacity of the insulating materials employed, permit considerable induction to take place between the core and the metallic armor or sheathing, or the ground.

The capacity of a cable depends on the capacity of the wire; *i. e.*, on its length and surface, on the specific inductive capacity of its insulation, and its neighborhood to the earth, or to other conducting wires, casings, armors, or metallic coatings. Submarine or underground cables therefore have a greater capacity than air lines.

This accumulation of electricity produces a retardation in the speed of signaling, because the wire must be charged before the signal is received at the distant end, and discharged or neutralized before a current can be sent in the reverse direction. This latter may be done by connecting each end to earth, or by the action of the reverse current itself.

The smaller the electrostatic capacity of a cable, therefore, the greater the speed of signaling. (See *Retardation*.)

The capacity of a cable is measured in *microfarads*. (See *Farad, Micro*.)

Cable Clip.—(See *Clip, Cable*.)

Cable-Core.—(See *Core of Cable*.)

Cable, Core-Ratio of — —The ratio between the diameter of the insulation of a cable and the mean diameter of the strand.

The core-ratio is represented by $\frac{D}{d}$; where D, is the diameter of the insulation, and d, the mean diameter of the strand. Should the extreme diameter of the strand of a cable be used in calculations for insulation resistance, inductive capacity, etc., erroneous values would be obtained. The measured diameter of the copper conductor is consequently decreased some five per cent., and, in this way, correct values are approximately obtained.—(*Clark & Sabine*.)

Cable, Duplex — —A conductor consisting of two separate cables placed parallel to each other.

The duplex cable is used especially in the alternating current system.

Cable, Electric — —The combination of an extended length of a single insulated conductor, or two or more separately insulated electric conductors, covered externally with a metallic sheathing or armor.

Strictly speaking, the word cable should be limited to the case of more than a single conductor. Usage, however, sanctions the employment of the word to indicate a single insulated conductor.

The conducting wire may consist of a single wire, of a number of separate wires electrically connected, or of a number of separate wires insulated from one another.

An electric cable consists of the following parts, viz.:

- (1.) The conducting wire or *core*.
- (2.) The insulating material for separating the several wires; and
- (3.) The *armor* or protecting covering, consisting of strands of iron wire, or of a metallic coating or covering of lead.

As to their position, cables are *aerial*, *submarine*, or *underground*. As to their purpose,

they are *telegraphic*, *telephonic*, or *electric light and power cables*. As to the number of their conductors they are *single-wire* or *bunched cables*. Bunched cables are *straightaway* or *twisted*.

Fig. 94 shows a form of submarine cable the

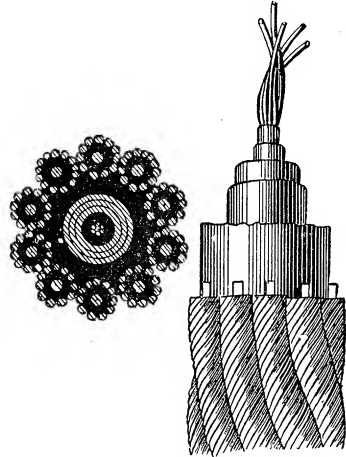

Fig. 94. Electric Cable.

armor of which is formed of strands of iron wire.

Cable, Electric Light or Power — —

A cable designed to distribute the electric current employed in electric light or power systems.

Electric light cables are generally *underground*. They may be *submarine*. (See *Cable, Electric*.)

Cable, Flat — —A cable, the separate conductors of which are laid-up side by side so as to form a flat conductor.

A flat cable is suitable for house work as being less objectionable in appearance when placed on the outside of ceilings or walls.

Cable, Flat Duplex — —A flat, laid-up cable containing two wires.

Cable-Grip.—(See *Grip, Cable*.)

Cable-Hanger.—(See *Hanger, Cable*.)

Cable-Hanger Tongs.—(See *Tongs, Cable-Hanger*.)

Cable Laid-Up in Layers.—A term applied to a cable, all the conducting wires of which are in layers.

Cable Laid-Up in Reversed Layers.—A term applied to a cable in which the conductors, in alternate layers, are twisted in opposite directions. (See *Cable, Bunched, Straight-away.*)

Cable Laid-Up in Twisted Pairs.—A term applied to a cable in which every pair of wires is twisted together. (See *Cable, Bunched, Twisted.*)

Cable Lead.—(See *Lead, Cable.*)

Cable, Multiple-Core — —A cable containing more than a single core.

Cable-Protector.—(See *Protector, Cable.*)

Cable-Serving.—(See *Serving, Cable.*)

Cable, Single-Wire — —A cable containing a single wire or conductor.

Cable, Sub-Aqueous — —An electric cable designed for use under water.

The term submarine is more frequently employed.

Cable, Submarine — —A cable designed for use under water.

Submarine cables are either *shallow-water*, or *deep-sea cables*. Gutta-percha answers admirably for the insulating material of the core. Various other insulators are also used.

Strands of tarred hemp or jute, known as the *cable-serving*, are wrapped around the insulated core in order to protect it from the pressure of the galvanized iron wire armor afterwards put on. To prevent corrosion the iron wire is covered with tarred hemp, galvanized, or otherwise coated.

Submarine cables are generally employed for telegraphic or telephonic communication. (See *Cable, Electric.*)

Cable, Submarine, Deep-Sea — —A submarine cable designed for use in deep water.

This form of cable is not so heavily armored as the shallow-water submarine cable.

Cable, Submarine, Shallow-Water — —A submarine cable designed for use in shallow water.

This cable is provided with a heavier armor or sheathing than a deep-sea cable to protect it from chafing due to the action of the waves and tides in shallow water. (See *Cable, Submarine.*)

Cable Support, Underground — —(See *Support, Underground Cable.*)

Cable Tank.—(See *Tank, Cable.*)

Cable, Telegraphic — —A cable designed to establish telegraphic communication between different points.

Telegraphic cables may be *aerial, submarine, or underground.* (See *Cable, Electric.*)

Cable, Telephonic — —A cable designed to establish telephonic communication between different points.

Telephonic cables may be *aerial, submarine, or underground.* (See *Cable, Electric.*)

Cable-Terminal.—(See *Terminal, Cable.*)

Cable, Torpedo — —A cable, in the circuit of which a torpedo is placed. (See *Torpedo, Electric.*)

Cable, Twisted-Pair — —A cable containing a single twisted pair, suitable for use as a lead and return, thus affording a metallic circuit.

Cable, Two, Three, Four, etc., Conductor — —A cable containing two, three, four, or more separate conducting wires.

Cable, Underground — —An electric cable placed underground.

The conducting wires of an underground cable are surrounded by a good insulating, water-proof substance, and protected by a sheathing or armor. A coating of lead is very generally employed for the sheathing or armor. Underground cables, in order to be readily accessible, should be placed in an underground conduit or subway. (See *Cable, Electric. Conduit, Underground Electric. Subway, Electric.*)

Cable-Worming.—(See *Worming, Cable.*)

Cablegram.—A message received by means of a submarine telegraphic cable.

Cables, Laying-Up — —The placing or disposing of the separate cables or conductors in a bunched cable.

The separate conductors in cables may be laid-up "*straightaway*" or "*twisted.*" (See *Cable, Bunched, Twisted. Cable, Bunched, Straight-away.*)

Cabling.—Sending a telegraphic dispatch by means of a cable.

Calahan's Stock Printer.—(See *Printer, Stock, Calahan's*.)

Calamine, Electric — —A crystalline variety of silicate of zinc that possesses pyroelectric properties. (See *Electricity, Pyro*.)

Cal-Electricity.—(See *Electricity, Cal*.)

Calibrate.—To determine the absolute or relative value of the scale divisions, or of the indications of any electrical instrument, such as a galvanometer, electrometer, voltmeter, wattmeter, etc.

Calibrating.—The act of determining the absolute or relative value of the deflections, or indications of an electric instrument.

Calibration, Absolute — —The determination of the absolute values of the reading of an electrometer, galvanometer, voltmeter, ampèremeter, or other similar instrument.

The calibration of a galvanometer, for example, consists in the determination of the law which governs its different deflections, and by which is obtained in ampères, either the absolute or the relative currents required to produce such deflections.

For various methods of calibration, see standard works on electrical testing, or on electricity.

Calibration, Invariable, of Galvanometer — —In galvanometers with absolute calibration, a method for preventing the occurrence of variations in the intensity of the field of the galvanometer, due to the neighborhood of masses of iron, etc.

Calibration, Relative — —The determination of the relative values of the reading of an electrometer, voltmeter, ampèremeter, or other similar instrument.

Caliper, Micrometer —

—A name sometimes given to a vernier wire gauge. (See *Gauge, Vernier Wire*.)

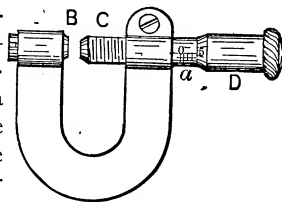

Fig. 95. *Micrometer Caliper.*

A form of micrometer caliper is shown in Fig. 95.

Call-Bell, Extension — —(See *Bell, Extension Call*.)

Call-Bell, Magneto-Electric — —An electric call-bell operated by currents produced by the motion of a coil of wire before the poles of a permanent magnet.

A well known form of magneto call-bell is shown

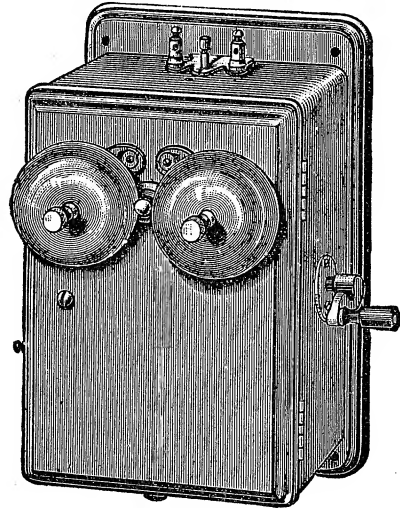

Fig. 96. *Magneto Call Bell.*

in Fig. 96. The armature is driven by the rotation of the handle.

Call-Bell, Telephone — —An electric bell, the ringing of which is used to call a person to a telephone.

Call, Electric Bell — —An electric bell sometimes used to call the attention of an operator to the fact that his correspondent wishes to communicate with him, or to notify an attendant that some service is desired.

Call, Messenger — —A district call-box. (See *Box, District Call*.)

Call, Thermo-Electric — —An instrument for sounding an alarm when the temperature rises above, or falls below, a fixed point.

In one form of thermo-electric call a needle is moved over a dial by a simple thermic device and rings a bell when the temperature for which it has been set is attained. The thermo-call is applicable to the regulation of the temperature of

dwellings, incubators, hot houses, breweries, drying rooms, etc.

Callaud Voltaic Cell.—(See *Cell, Voltaic, Callaud's*.)

Calling-Drop.—(See *Drop, Calling*.)

Calorescence.—The transformation of invisible heat-rays into luminous rays, when received by certain solid substances.

The term was proposed by Tyndall. The light from a voltaic arc is passed through a hollow glass lens filled with a solution of iodine in bisulphide of carbon.

This solution is opaque to light but quite transparent to heat.

If a piece of charred paper, or thin platinum foil, is placed in the *focus* of these invisible rays, it will be heated to brilliant incandescence. (See *Focus*.)

Caloric.—A term formerly applied to the fluid which was believed to be the cause or essence of heat.

The use of the word caloric at the present time is very unscientific, since heat is now known to be an effect of a wave motion and not a material thing. (See *Heat*.)

Calorie.—A heat unit.

There are two calories, the small and the large calorie.

The amount of heat required to raise the temperature of one gramme of water from 0 degree C. to 1 degree C. is called the *small calorie*.

The amount of heat required to raise 1,000 grammes, or a kilogramme, of water from 0 degree C. to 1 degree C. is called the *great calorie*. The first usage of the word is the commoner.

This word is sometimes spelled *calory*.

Calorie, Great — —The amount of heat required to raise the temperature of one kilogramme of water from 0 degree C. to 1 degree C.

Calorie, Small — —The amount of heat required to raise the temperature of one gramme of water from 0 degree C. to 1 degree C.

Calorimeter.—An instrument for measuring the amount of heat or thermal energy contained or developed in a given body.

Thermometers measure temperature only. A

thermometer plunged in a cup full of boiling water shows the same temperature that it would in a tub full of boiling water. The quantity of heat energy present in the two cases is of course greatly different, and can be measured by a calorimeter only.

Various forms of calorimeters are employed.

In order to determine the quantity of heat in a given weight of any body, this weight may be heated to a definite temperature, such as the boiling point of water, and placed in a vessel containing ice. The quantity of ice melted by the body in cooling to the temperature of the ice, is determined by measuring the amount of water derived from the melting of the ice. Care must be observed to avoid the melting of the ice by external heat.

In this way the amount of heat required to raise the temperature of a given weight of a body a certain number of degrees, or the capacity of the body for heat, may be compared with the capacity of an equal weight of water. This ratio is called the specific heat. (See *Heat, Specific*.)

The heat energy, present in a given weight of any substance at a given temperature, can be determined by means of a calorimeter; for, since a pound of water heated 1° F. absorbs an amount of energy equal to 772 foot-pounds, the energy can be readily calculated if the number of pounds of water and the number of degrees of temperature are known. (See *Heat, Mechanical Equivalent of*.)

Calorimeter, Electric — —An instrument for measuring the heat developed in a conductor or any piece of electrical apparatus, in a given time, by an electric current.

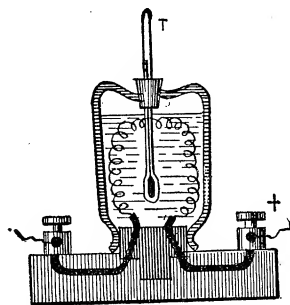

Fig. 97. *Electric Calorimeter.*

A vessel containing water is provided with a thermometer T, Fig. 97. The electric current

passes for a measured time through a wire immersed in the liquid.

The quantity of heat is determined from the increase of temperature, and the weight of the water heated.

According to Joule, the number of *heat units* developed in a conductor by an electric current is proportional:

- (1.) To the resistance of the conductor.
- (2.) To the square of the current passing.
- (3.) To the time the current is passing.

(See *Heat Unit, English.*)

The heating power of a current is as the square of the current only when the resistance remains the same. (See *Heat, Electric.*)

Calorimetric.—Pertaining to or by means of the calorimeter.

Calorimetric measurement is the measurement of heat energy made by means of the calorimeter. (See *Calorimeter.*)

Calorimetrically.—In a calorimetric manner.

Calorimetric Photometer.—(See *Photometer, Calorimetric.*)

Calorimotor.—A name applied to a deflagrator. (See *Deflagrator.*)

Calory.—A term used for *calorie*.

Calorie is the preferable orthography. (See *Calorie.*)

Cam, Electro-Magnetic — —A form of magnetic equalizer, which depends for its operation on the lateral approach of a suitably shaped polar surface. (See *Equalizer, Magnetic.*)

Cam, Listening — —In a telephone exchange system, a metallic cam by means of which an operator is placed in circuit with a subscriber.

Candle.—The unit of photometric intensity.

Such a light as would be produced by the consumption of two grains of a standard candle per minute.

An electric lamp of 16 candle-power, or one of 2,000 candle-power, is a light that gives respectively 16 or 2,000 times as much light as one standard candle.

Candle Burner, Electric — —(See *Burner, Electric Candle.*)

Candle, Electric — —A term applied to the Jablochhoff candle, and other similar devices. (See *Candle, Jablochhoff.*)

Candle, Foot — —A unit of illumination equal to the illumination produced by a standard candle at the distance of 1 foot.

According to this unit, the illumination produced by a standard candle at the distance of 2 feet would be but the one-fourth of a foot-candle; at 3 feet, the one-ninth of a foot-candle, etc.

The advantage of the proposed standard lies in the fact that knowing the illumination in foot-candles required for the particular work to be done, it is easy to calculate the position and intensity of the lights required to produce the illumination.

Candle, Jablochhoff — —An electric arc light in which the two carbon electrodes are placed parallel to each other and maintained a constant distance apart by means of a sheet of insulating material placed between them.

The Jablochhoff electric candle consists of two parallel carbons, separated by a layer of kaolin or other heat-resisting insulating material, as shown in Fig. 98. The current is passed into and out of the carbons at one end of the candle, and forms a voltaic arc at the other end. In order to start the arc, a thin strip called the *igniter*, consisting of a mixture of some readily ignitable substance, connects the upper ends of the carbons.

An alternating current is employed with these candles, thus avoiding the difficulty which would otherwise occur from the more rapid consumption of the positive than the negative carbon. (See *Current, Alternating.*)

Candle, Metre — —The illumination produced by a standard candle at the distance of one metre. (See *Candle, Foot.*)

Candle-Power.—(See *Power, Candle.*)

Candle-Power, Rated — —(See *Power, Candle, Rated.*)

Candle-Power, Spherical — —(See *Power, Candle, Spherical.*)

Candle, Standard — —A candle of



Fig. 98. Jablochhoff Candle.

definite composition which, with a given consumption in a given time, will produce a light of a fixed and definite brightness.

A candle which burns 120 grains of spermaceti wax per hour, or 2 grains per minute, will give an illumination equal to *one standard candle*.

Unless considerable care is taken, erroneous results will be obtained from the use of the standard candle. According to Slingo and Brooker the following are among the most important causes of these errors:

(1.) Defective forms of candle which cause a varying consumption of the material per second, and consequently a varying light for the standard candle.

(2.) Variations in the composition of the spermaceti of which the candle is composed. Spermaceti is not a definite chemical compound, but consists of a mixture of various substances; therefore, even if the consumption is maintained constant, the light-giving power is not necessarily constant.

(3.) Variations in the composition and character of the wick, such as the number and size of the threads of which it is formed and the closeness of the strands, all of which circumstances influence the amount of light given off by the candle.

(4.) The light emitted in certain directions varies in a marked degree with the shape of the wick. The mere bending of a wick may, therefore, cause the amount of light to vary considerably.

(5.) The light varies with the thickness of the wick. Thick wicks give less light than thin wicks.

(6.) The light given by the standard candle varies with the temperature of the testing-room. As the temperature rises the light given by the standard candle increases.

(7.) Currents of air, by producing variations in the amount of melting wax in the cup of the candle, vary the amount of light emitted.

These difficulties in obtaining a fixed amount of light from a standard candle, together with the difficulty of comparing the feeble light of a single candle with the light of a much more powerful source, such as an arc lamp, coupled with the additional difficulty arising from the difference in the colors of the lights, have led to the use of other standards of light than those furnished by the standard candle.

Caoutchouc. or India-Rubber.—A resin-

ous substance obtained from the milky juices of certain tropical trees.

Caoutchouc possesses high powers of electric insulation, and is used either pure or combined with sulphur.

Cap, Insulator — —A covering or cap placed some distance above an insulator, but separated from it by an air space.

Insulator caps are intended for protection of the insulators from injury by the throwing of stones or other malicious acts. Insulator caps are generally made of iron. They are highly objectionable, owing to the facility they offer for the accumulation of dust and dirt.

Capacity, Atomic — —The quantivalence or valency of an atom. (See *Atomizability*.)

Capacity, Dielectric — —A term employed in the same sense as specific inductive capacity. (See *Capacity, Specific Inductive*.)

Capacity, Electro-Dynamic — —A term formerly employed by Sir William Thomson for self-induction. (See *Induction, Self*.)

Capacity, Electrostatic — —The quantity of electricity which must be imparted to a given body or conductor as a charge, in order to raise its potential a certain amount. (See *Potential, Electric*.)

The electrostatic capacity of a conductor is not unlike the capacity of a vessel filled with a liquid or gas. A certain quantity of liquid will fill a given vessel to a level dependent on the size or capacity of the vessel. In the same manner a given quantity of electricity will produce, in a conductor or condenser, a certain difference of electric level, or difference of potential, dependent on the electrical capacity of the conductor or condenser.

Or, taking the analogous case of a gas-tight vessel, the quantity of gas that can be forced into such a vessel depends on the size of the vessel and the pressure with which it is forced in. A tension or pressure is thus produced by the gas on the walls of the vessel, which is greater the smaller the size of the vessel and the greater the quantity of gas forced in.

In the same manner, the smaller the capacity of a conductor, the smaller is the charge required

to raise it to a given potential, or the higher the potential a given charge will raise it.

The capacity K, of a conductor or condenser, is therefore directly proportional to the charge Q, and inversely proportional to the potential V; or,

$$K = \frac{Q}{V}.$$

From which we obtain $Q = KV$; or,

The quantity of electricity required to charge a conductor or condenser to a given potential is equal to the capacity of the conductor or condenser multiplied by the potential through which it is raised.

Capacity, Electrostatic, Unit of — —

Such a capacity of a conductor or condenser that an electromotive force of one volt will charge it with a quantity of electricity equal to one coulomb.

The farad. (See *Farad*.)

Capacity of Cable.—(See *Cable, Capacity of*.)

Capacity of Condenser.—(See *Condenser, Capacity of*.)

Capacity of Leyden Jar.—(See *Jar, Leyden, Capacity of*.)

Capacity of Line.—(See *Line, Capacity of*.)

Capacity of Polarization of a Voltaic Cell.—(See *Cell, Voltaic, Capacity of Polarization of*.)

Capacity, Safe Carrying, of a Conductor — —
— —The maximum electric current the conductor will carry without becoming unduly heated.

Capacity, Specific Inductive — —
The ability of a dielectric to permit induction to take place through its mass, as compared with the ability possessed by a mass of air of the same dimensions and thickness, under precisely similar conditions.

The relative power of bodies for transmitting electrostatic stresses and strains analogous to permeability in metals.

The ratio of the capacity of a condenser whose coatings are separated by a dielectric of a given substance to the capacity of a similar condenser whose plates are separated by a plate or layer of air.

The inductive capacity of a dielectric is compared with that of air.

According to Gordon and others, the specific inductive capacities of a few substances, compared with air, are as follows:

Air.....	1.00
Glass.....	3.013 to 3.258
Shellac.....	2.740
Sulphur.....	2.580
Gutta-percha.....	2.462
Ebonite.....	2.284
India-rubber.....	2.220 to 2.497
Turpentine.....	2.160
Petroleum.....	2.030 to 2.070
Paraffin (solid).....	1.994
Carbon bisulphide.....	1.810
Carbonic acid.....	1.00036
Hydrogen.....	0.99967
Vacuum.....	0.99941

Faraday, who proposed the term *specific inductive capacity*, employed in his experiments a condenser consisting of a metallic sphere A, Fig. 99, placed inside a large hollow sphere B.

The concentric space between A and B was filled with the substance whose specific inductive capacity was to be determined.

Capacity, Specific Magnetic — — A term sometimes employed in the sense of magnetic permeability.

Conductibility for lines of magnetic force in the same sense that specific inductive capacity is conductibility for lines of electrostatic force.

This term has received the name of specific magnetic capacity in order to distinguish it from specific inductive capacity. The velocity of propagation of waves in any elastic medium is proportional to the quotient obtained by extracting the square root of the elasticity of the medium divided by the square root of its density; or,

$$V = \sqrt{\frac{E}{D}}$$

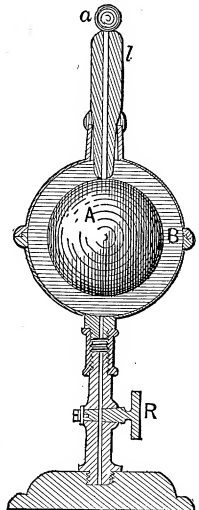

Fig 99. Condenser.

Similarly, the speed with which inductive waves travel depends on the relation between the elasticity and the density of the medium. Calling $\frac{1}{K}$, the electric elasticity, then its reciprocal, K , corresponds with the dielectric capacity. The electrical density, μ , corresponds with the magnetic permeability. The velocity of wave transmission is therefore,

$$V = \sqrt{\frac{\frac{1}{K}}{\mu}} = \frac{1}{\sqrt{K \times \mu}}$$

Capacity, Storage, of Secondary Cell —
—(See *Cell, Secondary or Storage, Capacity of.*)

Capillarity.—The elevation or depression of liquids in tubes of small internal diameter.

The liquid is elevated when it wets the walls, and depressed when it does not wet the walls of the tube.

The phenomena of capillarity are due to the mutual attractions existing between the molecules of the liquid for one another, and the mutual attraction between the molecules of the liquid and those of the walls of the tube.

In capillarity, therefore, the approximately level surface caused by the equal attraction of all the molecules towards the earth's centre is disturbed by the unequal attraction exerted on each molecule by the walls of the tube and by the remaining molecules.

Capillarity, Effects of, on Voltaic Cell —
—Effects caused by capillary action which disturb the proper action of a voltaic cell.

These effects are as follows:

(1.) Creeping, or efflorescence of salts. (See *Creeping, Electric. Efflorescence.*)

(2.) Oxidation of contacts and consequent introduction of increased resistance into the battery circuit. The liquid enters the capillary spaces between the contact surfaces and oxidizes them.

Capillary.—Of a small or hair-like diameter or size.

A capillary tube is a tube of small hair-like diameter. (See *Capillarity.*)

Capillary Attraction.—(See *Attraction, Capillary.*)

Capillary Contact-Key.—(See *Key, Capillary Contact.*)

Capillary Electrometer.—(See *Electrometer, Capillary.*)

Carbon.—An elementary substance which occurs naturally in three distinct allotropic forms, viz.: charcoal, graphite and the diamond. (See *Allotropy.*)

Carbon-Brushes for Electric Motors.—
(See *Brushes, Carbon, for Electric Motors.*)

Carbon Button.—(See *Button, Carbon.*)

Carbon-Clutch or Clamp of Arc Lamp.
—(See *Clutch, Carbon, of Arc Lamp.*)

Carbon-Electrodes for Arc Lamps.—(See *Electrodes, Carbon, for Arc Lamps.*)

Carbon-Holders for Arc Lamps.—(See *HOLDERS, Carbon, for Arc Lamps.*)

Carbon Points.—(See *Points, Carbon.*)

Carbon Transmitter for Telephones.—
(See *Transmitter, Carbon, for Telephones.*)

Carbonic Acid Gas.—(See *Gas, Carbonic Acid.*)

Carboning Lamps.—(See *Lamps, Carboning.*)

Carbonizable.—Capable of being carbonized. (See *Carbonization, Processes of.*)

Carbonization.—The act of carbonizing. (See *Carbonization, Processes of.*)

Carbonization, Processes of — —
Means for carbonizing material.

The carbonizable material is placed in suitably shaped boxes, covered with powdered plumbago or lamp-black, and subjected to the prolonged action of intense heat while out of contact with air.

The electrical conducting power of the carbon which results from this process is increased by the action of the heat, and, probably, also, by the deposit in the mass, of carbon resulting from the subsequent decomposition of the hydro-carbon gases produced during carbonization.

When the carbonization is for the purpose of producing conductors for incandescent lamps, in order to obtain the uniformity of conducting power, electrical homogeneity, purity and high refractory power requisite, selected fibrous material, cut or shaped in at least one dimension

prior to carbonization, must be taken, and subjected to as nearly uniform carbonization as possible.

Carbonize.—To reduce a carbonizable material to carbon. (See *Carbonization, Processes of.*)

Carbonized Cloth Discs for High Resistances.—(See *Cloth Discs Carbonized, for High Resistances.*)

Carbonizer.—Any apparatus suitable for reducing carbonizable material to carbon.

Carbonizing.—Subjecting a carbonizable substance to the process of carbonization. (See *Carbonization, Processes of.*)

Carbons, Artificial — —Carbons obtained by the carbonization of a mixture of pulverized carbon with different carbonizable liquids.

Powdered coke, or gas-retort carbon, sometimes mixed with lamp-black or charcoal, is made into a stiff dough with molasses, tar, or any other hydro-carbon liquid. The mixture is molded into rods, pencils, plates, bars or other desired shapes by the pressure of a powerful hydraulic press. After drying, the carbons are placed in crucibles and covered with lamp-black or powdered plumbago, and raised to an intense heat at which they are maintained for several hours. By the carbonization of the hydro-carbon liquids, the carbon paste becomes strongly coherent, and by the action of the heat its conducting power increases.

To give increased density after baking, the carbons are sometimes soaked in a hydro-carbon liquid, and subjected to a re-baking. This may be repeated a number of times.

Carbons, Concentric-Cylindrical — — A cylindrical rod of carbon placed inside a hollow cylinder of carbon but separated from it by an air space, or by some other insulating, refractory material.

Jablochkoff candles sometimes are made with a solid cylindrical electrode, concentrically placed in a hollow cylindrical carbon.

Carbons, Cored — —A cylindrical carbon electrode for an arc lamp that is molded around a central core of charcoal, or other softer carbon.

Much of the unsteadiness of the arc light is due to changes in the position of the arc. Cored carbons, it is claimed, render the arc light steadier, by maintaining the arc always at the softer carbon and hence at the central point of the electrode.

A core of harder carbon, or other refractory material, is sometimes provided for the negative carbon.

Carbons, Flashed — —Carbons which have been subjected to the flashing process. (See *Carbons, Flashing Process for.*)

Carbons, Flashing Process for — —A process for improving the electrical uniformity of the carbon conductors employed in incandescent lighting, by the deposition of carbon in their pores, and over their surfaces at those places where the electric resistance is relatively great.

The carbon conductor or filament is placed in a vessel filled with the vapor of a hydrocarbon liquid called rhigolene, or any other readily decomposable hydrocarbon liquid, and gradually raised to electric incandescence by the passage through it of an electric current. A decomposition of the hydrocarbon vapor occurs, the carbon resulting therefrom being deposited in and on the conductor.

As the current is gradually increased, the parts of the conductor first rendered incandescent are the places where the electric resistance is the highest, these parts, therefore, and practically these parts only, receive the deposit of carbon. As the current increases, other portions become successively incandescent and receive a deposit of carbon, until at last the filament glows with a uniform brilliancy, indicative of its electric homogeneity.

A carbon whose resistance varies considerably at different parts could not be successfully employed in an incandescent lamp, since if heated by a current sufficiently great to render the points of comparatively small resistance satisfactorily incandescent, the temperature of the points of high resistance would be such as to lower the life of the lamp, while if only those portions were safely heated, the lamp would not be economical. The flashing process is therefore of very great value in the manufacture of an incandescent lamp.

The name "flashing" was applied to the process by reason of the flashing light emitted by the

carbons when they have been sufficiently treated. The process requires so little time that the dull red which first appears soon flashes to the full luminosity required.

The term "flashing" is sometimes applied to the electrical heating to incandescence, while the carbons are in the lamp chambers, and on the pumps. This flashing is for the purpose of driving off all the gases occluded by the carbon, so that these gases may be carried off by the operation of pumping. This process is more properly called the process for driving off the occluded gases.

The carbons are sometimes flashed in the liquid itself instead of in its vapor.

Carbons, Paper — —Carbons, of textile or fibrous origin, obtained from the carbonization of paper.

The carbonization of paper is readily effected by submitting the paper to the prolonged action of a high temperature while out of contact with air.

For this purpose the paper is packed in retorts or crucibles, and covered with lamp-black, or powdered plumbago, in order to exclude the air.

Since paper consists of a plane of material uniformly thin in one direction, formed almost entirely of fibres of pure cellulose, the greatest length of which extends in a direction nearly parallel to that in which the paper is uniformly thin, it is clear that sheets of this substance, when carbonized, should yield flexible carbons of unusual purity and electrical homogeneity, since such carbons are structural in character, and are uniformly affected by the heat of carbonization to an extent that would be impossible by the carbonization of any material in a mass.

Carcass of Dynamo-Electric Machine. — (See *Machine, Dynamo-Electric, Carcass of.*)

Carcel. — The French unit of light. The light emitted by a lamp burning 42 grammes of pure colza oil per hour, with a flame 40 millimetres in height.

The bec-carcel. One carcel = 9.5 to 9.6 standard candles.

Carcel Lamp. — (See *Lamp, Carcel.*)

Carcel Standard Gas Jet. — (See *Jet, Gas, Carcel Standard.*)

Card, Compass — —A card used in the mariner's compass, on which are marked the

four cardinal points of the compass N, S, E and W, and these again divided into thirty-two points called Rhumbs. (See *Compass, Azimuth.*)

Cardew Voltmeter. — (See *Voltmeter, Cardew.*)

Carriage, Pen — —The carriage in an electric chronograph which holds the pen and moves over the sheet of paper on which the record is made. (See *Chronograph, Electric.*)

Carriers of Replenisher. — (See *Replenisher, Carriers of.*)

Cascade, Charging Leyden Jars by — —A method of charging jars or condensers by means of the free electricity liberated by induction from one coating, when a charge is passed into the other coating.

The jars are placed as shown in Fig. 100, with the inside coating of the first jar connected with the outside coating of the one next it. There is in

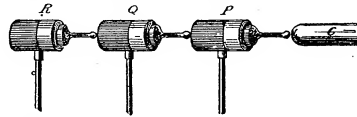

Fig. 100. Cascade Charging of Leyden Jars.

reality no increase in the entire charge obtained in charging by cascade, since the sum of the charges given to the separate jars is equal to the same charge given to a single jar separately charged.

The energy of the discharge in cascade can be shown to be less than that of the same charge when confined to a single jar. This is of course to be expected, since it is energy that is charged in the jar and not electricity, and, of course, the energy charged in the jar can never exceed the energy employed in charging the jar. There is a small loss for each jar, and this increases necessarily with each jar added.

Cascade, Connection of Electric Sources in — —A term sometimes used for series-connection of electric sources.

The term series-connection is the preferable one. (See *Connection, Series.*)

Case-Hardening, Electric — —Superficially converting a piece of wire into steel by electrically produced heat.

In electric case-hardening, the superficial layers of a piece of iron are converted into steel by electrically heating the same, while surrounded by a layer of case-hardening flux and carbonaceous substances such as animal charcoal, shavings of horn, leather cuttings or other similar substances.

In the case of a readily oxidizable metal like iron, oxidation is prevented by surrounding the metal by a hydrocarbon gas, which, when sufficiently heated, deposits on the surfaces a protective coating of carbon. This layer of carbon gradually carbonizes the iron.

Case Wiring.—(See *Wiring, Case*.)

Cataphoresis.—A term sometimes employed in place of electric osmose. (See *Osmose, Electric*.)

The word cataphoresis applies to the cases where medicinal substances, such as iodine, cocaine, quinine, etc., are caused to pass through organic tissues in the direction of flow of an electric current, or from the anode to the kathode. This action is probably due to an electrolytic action.

Cataphoric Action.—(See *Action, Cataphoric*.)

Catch, Safety — —A wire, plate, strip, or box of readily fusible metal, capable of conducting, without fusing, the current ordinarily employed on the circuit, but which fuses and thus breaks the circuit on the passage of an abnormally large current.

Safety-catches are generally placed on multiple-arc and multiple-series circuits. (See *Fuse, Safety*.)

Catelectrotonus.—An orthography sometimes applied to Kathelectrotonus. (See *Kathelectrotonus*.)

Cathetometer.—An instrument for the accurate measurement of vertical height.

The cathetometer consists essentially of an accurately divided vertical rod which carries a sliding support for a telescope. The telescope is provided with two spider lines at right angles to one another, so placed as to be seen in front of the object whose height is to be measured. From observations taken in different positions, the measurement of the true vertical height is readily obtained.

Cathion.—A term sometimes used instead of Kathion.

More correctly written Kathion. (See *Kathion*.)

Cathode.—A term sometimes used instead of Kathode.

Catoptrics.—That branch of optics which treats of the reflection of light.

Causty, Galvano — —A term sometimes used for galvano-cautery. (See *Cautery, Galvano*.)

Cauterization.—The act of cauterizing, or burning with a heated solid or caustic substance.

Cauterization, Electric — —Subjecting to cauterization by means of a wire electrically heated. (See *Cautery, Electric*.)

Cauterize.—To subject to cauterization, or burning with a heated solid or caustic substance.

Cauterizer, Electric — —A term sometimes applied to an electric cautery. (See *Cautery, Electric*.)

Cautery, Actual — —A burning or searing with a white-hot metal.

Cautery Battery.—(See *Battery, Cautery*.)

Cautery, Electric — —An instrument used for electric cauterization.

In electro-therapeutics, the application of variously shaped platinum wires heated to incandescence by the electric current in place of a knife, for removing diseased growths, or for stopping hemorrhages.

The operation, though painful during application, is afterward less painful than that with a knife, since secondary hemorrhage seldom occurs, and the wound rapidly heals.

Electric cautery is applicable in cases where the knife would be inadmissible owing to the situation of the parts or their surroundings.

Cautery, Galvano — —A term frequently employed in place of electric cautery. (See *Cautery, Electric*.)

Cautery, Galvano Electric — —An electric cautery. (See *Cautery, Electric*.)

Cautery, Galvano Thermal — —A term sometimes used for an electric cautery. (See *Cautery, Electric*.)

Cautery-Knife Electrode.—(See *Electrode Cautery-Knife*.)

Cautery, Thermal — —A cautery heated by heat other than that of electric origin, as distinguished from an electric cautery. (See *Cautery, Electric*.)

Ceiling Rose.—(See *Rose, Ceiling*.)

Cell, Depositing — —An electrolytic cell in which an electro-metallurgical deposit is made. (See *Metallurgy, Electro*.)

Cell, Electrolytic — —A cell or vessel containing an electrolyte, in which electrolysis is carried on.

An electrolytic cell is called a *voltmeter* when the value of the current passing is deduced from the weight of the metal deposited.

Cell, Impulsion — —A photo-electric cell whose sensitiveness to light may be restored or destroyed by slight impulses given to the plates, such as by blows or taps, or electro-magnetic impulses.

An impulsion cell may be prepared by pasting pieces of tin-foil, the opposite faces of which are respectively polished and dull, on the opposite faces of a plate of glass, so as to expose dissimilar sides to the light, when the cells are dipped in alcohol.

Cell, Photo-Electric — —A cell capable of producing differences of potential when its opposite faces are unequally exposed to radiant energy.

Photo-voltaic cells are made in a variety of forms, both with selenium and with different metallic substances. (See *Cell, Selenium*.)

Cell, Porous — —A jar of unglazed earthenware, employed in double-fluid voltaic cells, to keep the two liquids separated.

The use of a porous cell necessarily increases the internal resistance of the cell, from the decrease it produces in the area of cross section of liquid between the two elements. When the battery is dismantled, the porous cells should be kept under water, otherwise the crystallization of the zinc sulphate or other salt is apt to produce serious exfoliation, or scaling off, or even to crumble the porous cell.

A porous cell is sometimes called a *diaphragm*, but only properly so when the cell is reduced to a single separating plate. (See *Cell, Voltaic*.)

Cell, Secondary — —A term sometimes used instead of storage cell.

The term secondary cell is used in contradistinction to primary or voltaic cell.

Cell, Secondary or Storage, Boiling of — —A term, sometimes applied to the gassing of a storage cell. (See *Cell, Storage, Gassing of*.)

Cell, Secondary or Storage, Capacity of — —The product of the current in amperes, by the number of hours the battery is capable of furnishing said current, when fully charged, until exhausted.

The capacity of storage cells is given in ampère-hours. A storage battery with a capacity of 1,000 ampère-hours can furnish, say a current of fifty ampères for twenty hours, or a current of one hundred ampères for ten hours; or a current of twenty-five ampères for forty hours.

Cell, Secondary or Storage, Gassing of — —An escape of gas due to the decomposition of water on passage of too strong a charging current.

Cell, Secondary or Storage, Renovation of — —The revivifying or recharging of a run-down, or discharged storage cell.

Cell, Secondary or Storage, Time-Fall of Electromotive Force of — —(See *Force, Electromotive of Secondary or Storage Cell, Time-Fall, of*.)

Cell, Secondary or Storage, Time-Rise of Electromotive Force of — —(See *Force, Electromotive of, Secondary or Storage Cell, Time-Rise, of*.)

Cell, Selenium — —A cell consisting of a mass of selenium fused in between two conducting wires or electrodes of platinumized silver or other suitable metal.

A convenient manner of forming a selenium cell is to wind two separate spirals of platinumized silver wire around a cylinder of hard wood, taking care to maintain them a constant distance apart, so as to avoid contact between them. The space between these wires is filled with fused selenium, which is allowed to cool gradually.

Exposure to sunlight reduces the resistance of a selenium cell to about one-half its resistance in

the dark, but neither the resistance nor the reduction ratio long remains constant.

A selenium cell produces a difference of potential, or electromotive force, when one of its electrode faces is exposed to light, while the other is kept in darkness.

According to Von Uljanin, who experimented with selenium melted in between two parallel platinized plates, cooled under pressure, and then reduced from the amorphous to the sensitive crystalline variety by gradual cooling after two or three heatings in a paraffine bath up to 195 degrees, the following peculiarities were observed:

(1.) Exposure of one of the electrodes to sunlight produced an electromotive force which causes a current to flow from the dark to the illumined electrode.

(2.) The maximum electromotive force was 0.12 volt.

(3.) The electromotive force disappeared instantaneously and completely on the darkening of the electrodes.

(4.) A slight difference in the electromotive force was observed when the positive and negative electrodes were alternately exposed to the light, the maximum electromotive force being attained by the exposure of the negative electrode.

(5.) If both electrodes are similarly illumined the resulting current strength is decreased and may reach zero.

(6.) The action of light is instantaneous.

(7.) Most of the selenium cells experimented with exhibited an electromotive force of polarization.

(8.) The electromotive force of polarization is diminished by exposure to light.

(9.) The electrical resistance and sensitiveness to light as regards the production of an electromotive force decrease with time. This is probably due to a gradual change in the allotropic state of the selenium. (See *State, Allotropic.*)

(10.) The electromotive force produced is proportional to the intensity of the illumination only when the obscure rays or heat rays are absent.

(11.) Of different wave lengths the orange-yellow rays in the diffraction spectrum, and the greenish-yellow in the prismatic spectrum produced the greatest effect.

Among some of the more recent applications of selenium cells are the following:

(1.) A selenium cell is so placed in a circuit containing an electro-magnet and switch, that on

one of its electrodes being exposed to the decreased illumination of coming night it automatically turns on an electric lamp, and, conversely, on the approach of daylight, and the consequent illumination of the electrode, turns it off.

(2.) A device whereby the presence of light, as for example that carried by a burglar, automatically rings an alarm and thus calls the attention of the watchman of the building.

Cell, Standard — —(See *Cell, Voltaic, Standard.*)

Cell, Storage — —Two relatively inert plates of metal, or of metallic compounds, immersed in an electrolyte incapable of acting considerably on them until after an electric current has been passed through the liquid from one plate to the other and has changed their chemical relations.

A single one of the cells required to form a secondary battery.

Sometimes, the jar containing a single cell is called a storage cell.

This latter use of the word is objectionable.

A storage cell is also called an accumulator.

On the passage of an electric current through the electrolyte, its decomposition is effected and the electro-positive and electro-negative radicals are deposited on the plates, or unite with them, so that on the cessation of the charging current, there remains a voltaic cell capable of generating an electric current.

A storage cell is *charged* by the passage through the liquid from one plate to the other of an electric current, derived from any external source. The *charging current* produces an electrolytic decomposition of the inert liquid between the plates, depositing the *electro-positive radicals, or kathions*, on the plate connected with the negative terminal of the source, and the *electro-negative radicals, or anions*, on the plate connected with the positive terminal.

On the cessation of the charging current, and the connection of the charged plates by a conductor outside the liquid, a current is produced, which flows through the liquid from the plate covered with the electro-positive radicals, to that covered with the electro-negative radicals, or in the *opposite direction to that of the charging current.*

The simplest storage cell is Planté's cell, which, as originally constructed, consists of two plates of

lead immersed in dilute sulphuric acid, H_2SO_4 . On the passage of the charging current, the plates A and B, Fig. 101, dipped in H_2SO_4 , are covered respectively with lead peroxide, PbO_2 , and finely divided, spongy lead. The peroxide is formed on the positive plate, and the metallic lead on the negative plate. The acid and water should have a specific gravity of about 1.170. When the cell is fully charged the acid solution loses its clearness and becomes milky in appearance, and the

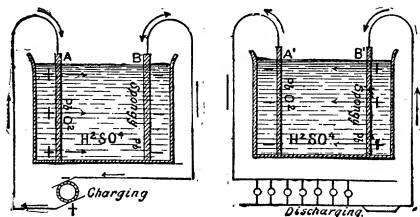

Figs. 101 and 102. Storage Cell.

specific gravity increases to 1.195. This increase is a good sign of a full charge.

When the charging current ceases to pass, the cell discharges in the opposite direction, viz., from B' to A', that is, from the spongy lead plate to the peroxide plate through the electrolyte, as shown in Fig. 102.

As a result of this discharging current the peroxide, PbO_2 , on A', gives up one of its atoms of oxygen to the spongy lead on B', thus leaving both plates coated with a layer of PbO , lead monoxide, or litharge. When this change is thoroughly effected, the cell becomes inert, and will furnish no further current until again charged by the passage of a current from some external source.

In order to increase the capacity of the storage cells, and thus prolong the time of their discharge, the coating of lead monoxide thus left on each of the plates, when neutral, is made as great as possible. To effect this, a process called "*forming the plates*" is employed, which consists in first charging the plates as already described, and then reversing the direction of the charging current, the currents being sent through the cell in alternately opposite directions, until a considerable depth of the lead plates has been acted on.

It will be noticed that during the action of the *charging* current, the oxygen is transferred from the PbO , on one plate, to the PbO , on the other plate, thus leaving one Pb , and the other PbO_2 ; and that on *discharging*, one atom of oxygen is

transferred from the PbO_2 , to the Pb , thus leaving both plates covered with PbO . In reality this is but the final result of the action, hydrated sulphate of lead, PbO, H_2SO_4 , being formed, and subsequently decomposed. Other compounds are formed that are but imperfectly understood.

In order to decrease the time required for forming, accumulators, or secondary cells, have been constructed, in which metallic plates covered with *red lead* Pb_3O_4 replace the lead plates in the original Planté cell. On charging, the Pb_3O_4 is peroxidized at the *anode*, i. e., converted into PbO_2 , and deoxidized, and subsequently converted into metallic lead at the *cathode*. Or, in place of the above Pb_3O_4 , red lead is placed on the anode and PbO , or *litharge*, on the cathode.

Plates of compressed litharge have also been recently used for this purpose. Storage cells so formed have a greater storage capacity per unit weight than those in which a grid is employed, but a higher resistance.

In all cases where a metal plate is employed various irregularities of surface are given to the plates, in order to increase their extent of surface and to afford a means for preventing the separation of the coatings. The metallic form thus provided is known technically as a *grid*.

Unless care is exercised, the plates will *buckle* from the difference in the expansion of the lead and its filling of oxide. This buckling is attended with an increase in the resistance of the cell and the gradual separation of the oxides that cover or fill it.

Cell, Thermo-Electric — —A name applied to a thermo-electric couple. (See *Couple, Thermo-Electric*.)

Cell, Voltaic — —The combination of two metals, or of a metal and a metalloid, which, when dipped into a liquid or liquids called electrolytes, and connected outside the liquid or liquids by a conductor, will produce a current of electricity.

Different liquids or gases may take the place of the two metals, or of the metal and metalloid. (See *Battery, Gas*.)

Plates of zinc and copper dipped into a solution of sulphuric acid and water, and connected outside the liquid by a conductor, form a simple voltaic cell.

If the zinc be of ordinary commercial purity,

and is not connected outside the liquid by a conductor, the following phenomena occur:

(1.) The sulphuric acid or hydrogen sulphate, H_2SO_4 , is decomposed, zinc sulphate, $ZnSO_4$, being formed, and hydrogen, H_2 , liberated.

(2.) The hydrogen is liberated mainly at the surface of the zinc plate.

(3.) The entire mass of the liquid becomes heated.

If, however, the plates are connected outside the liquid by a conductor of electricity, then the phenomena change and are as follows, viz.:

(1.) The sulphuric acid is decomposed as before; but,

(2.) The hydrogen is liberated at the surface of the copper plate only.

(3.) The heat no longer appears in the liquid only, but in all parts of the circuit.

(4.) An electric current now flows through the entire circuit, and will continue so to flow as long as there is any sulphuric acid to be decomposed, and zinc with which to form zinc sulphate.

The energy which previously appeared as heat only, now appears in part as electric energy.

Therefore, although the mere contact of the two metals with the liquid will produce a difference of potential, it is the *chemical potential energy* which became *kinetic* during chemical combination that supplies the energy required to maintain the electric current. (See *Energy, Kinetic, Energy, Potential.*)

A voltaic cell consists of two plates of different metals, or of a metal and a metalloid (or of two gases, or two liquids, or of a liquid and a gas), each of which is called a *voltaic element*, and which, taken together, form what is called a *voltaic couple*.

The *voltaic couple* dips into a liquid called an *electrolyte*, which, as it transmits the electric current, is decomposed by it. The elements are connected outside the electrolyte by any conducting material.

Direction of the Current.—In any voltaic cell the current is assumed to flow *through the liquid*, from the metal most acted on to the metal least acted on, and *outside the liquid*, through the outside circuit, from the metal least acted on to the metal most acted on.

In Fig. 103 a *zinc-copper* voltaic couple is shown, immersed in dilute sulphuric acid. Here, since the zinc is dissolved by the sulphuric acid, the zinc is positive, and the copper negative in the liquid. The zinc and copper are of opposite polarities out of the liquid.

There is still a considerable difference of opinion as to the exact cause of the potential difference of the voltaic cell. There can be no doubt that a true contact force exists, but the chemical potential energy of the positive plate is the source of energy which maintains the potential difference.

The difference in the polarity of the zinc and copper in and out of the liquid is generally denied by most of the later writers on electricity, since tests by a sufficiently delicate electrometer show that the entire zinc plate is negative and the entire copper plate positive. Remembering, however, the convention as to the direction of the flow of the current, since the current flows from the zinc to the copper through the liquid, we may still fairly regard the zinc as positive and the copper as negative in the liquid. It will be remembered, that in every source the polarity within the source is necessarily opposite to the polarity outside it. The copper plate is therefore called the *negative plate*, and the wire connected to its end out of the liquid, the *positive electrode*. Similarly, the zinc plate is called the *positive plate*, and the wire connected to it the *negative electrode*.

It will of course be understood that in the above sketch the current flows only on the completion of the circuit outside the cell; that is, when the conductors attached to the zinc and copper plates are electrically connected.

Amalgamation of the Zinc Plate.—When zinc is used for the positive element, it will, unless chemically pure, be dissolved by the electrolyte when the circuit is open, or will be irregularly dissolved when the circuit is closed, producing currents in little closed circuits from minute voltaic couples formed by the zinc and such impurities as *carbon, lead, or iron*, etc., always found in commercial zinc. (See *Action, Local, of Voltaic Cell.*) As it is practically impossible to obtain chemically pure zinc, it is necessary to *amalgamate* the zinc plate; that is, to cover it with a thin layer of zinc amalgam.

Polarization of the Negative Plate.—Since the evolved hydrogen appears at the surface of the negative plate, the surface of this plate, unless

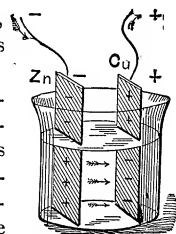

Fig. 103. Voltaic Couple.

means are adopted to avoid it, will, after a while, become coated with a film of hydrogen gas, or as it is technically called, will become polarized. (See *Cell, Voltaic, Polarization of.*)

The effect of this polarization is to cause a falling off or weakening of the current produced by the battery, due to the formation of a *counter-electromotive force* produced by the hydrogen-covered plate; that is to say, the negative plate, now being covered with hydrogen, a very highly electro-positive element, tends to produce a current in a direction opposed to that of the cell proper. (See *Force, Electromotive, Counter.*)

This decrease in current strength is rendered still greater by the increased resistance in the cell, due to the bubbles of hydrogen, and to the decreased electromotive force, due to the increase in the density of the zinc sulphate, in the case of zinc in hydrogen sulphate.

In the case of *storage cells*, the counter-electromotive force of polarization is employed as the source of *secondary currents*. (See *Electricity, Storage of. Cell, Secondary. Cell, Storage.*)

In order to avoid the effects of polarization in voltaic cells, and thus insure constancy of current, the bubbles of gas at the negative plate are mechanically carried off either by roughening its surface, by forcing the electrolyte against the plate as by shaking, or by a stream of air; or else the negative plate is surrounded by some liquid or solid substance which will remove the hydrogen, by entering into combination with it. (See *Cell, Voltaic, Polarization of.*)

Voltaic cells are therefore divided into cells with one or with two fluids, or electrolytes, or into:

- (1.) Single-fluid cells; and
- (2.) Double-fluid cells.

Very many forms of voltaic cells have been devised. The following are among the more important, viz.: Of the Single-Fluid Cells, the *Grenet*, *Poggendorff*, or *Bichromate*, the *Zinc-Copper*, the *Zinc-Carbon* and the *Smee*. Of the Double-Fluid Cells, *Grove's*, *Bunsen's*, *Callaud* or *Gravity*, *Daniell's*, *Leclanché*, *Siemens-Halske* and the *Meidinger*.

Of all the voltaic cells that have been devised two only, viz., the *Gravity*, a modified *Daniell*, and the *Leclanché*, have continued until now in very general use, the gravity cell being used on *closed-circuited lines*, and the *Leclanché* on *open-circuited lines*; the former being the best suited

of all cells to furnish the *continuous constant currents* employed in most systems of telegraphy, and the latter for furnishing the *intermittent currents* required for ringing bells, operating annunciators, or for similar work.

Cell, Voltaic, Absorption and Generation of Heat in — (See *Heat, Absorption and Generation of, in Voltaic Cell.*)

Cell, Voltaic, Bichromate — — A zinc-carbon couple used with an electrolyte known as *electropoion*, a solution of bichromate of potash and sulphuric acid in water. (See *Liquid, Electropoion.*)

Bichromate of sodium or chromic acid are sometimes used instead of the bichromate of potassium.

The zinc, Fig. 104, is amalgamated and placed between two carbon plates. The terminals connected with the zinc and carbon are respectively *negative* and *positive*. In the form shown in the figure, the zinc plate can be lifted out of the liquid when the cell is not in action.

The bichromate cell is excellent for purposes requiring strong currents where long action is not necessary. As this cell readily polarizes it cannot be advantageously employed continuously for any considerable period of time. It becomes depolarized, however, when left for some time on open circuit.

The following chemical reaction probably takes place when the cell is furnishing current, viz.:

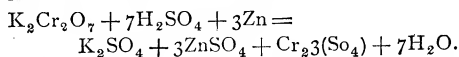

This cell gives an electromotive force of about 1.9 volts.

Cell, Voltaic, Bunsen's — — A zinc-carbon couple, the elements of which are immersed respectively in electrolytes of dilute sulphuric and strong nitric acids.

Bunsen's cell is the same as *Grove's*, except that the platinum is replaced by carbon. The zinc surrounds the porous cell containing the car-

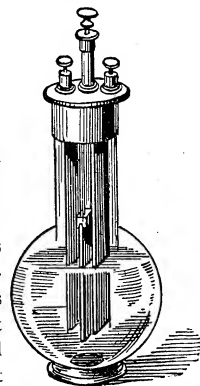

Fig. 104. Bichromate Cell.

bon. The polarity is as indicated in Fig. 105. (See *Cell, Voltaic, Grove.*)

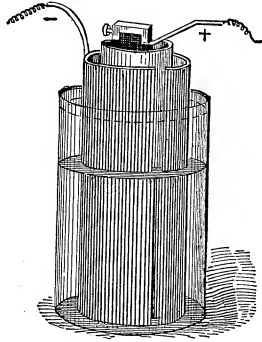

Fig. 105. Bunsen Cell.

The Bunsen cell gives an electromotive force of about 1.96 volts.

Cell, Voltaic, Callaud's — — A name sometimes given to the gravity cell. (See *Cell, Voltaic, Gravity.*)

Cell, Voltaic, Capacity of Polarization of — — The quantity of electricity required to be discharged by a voltaic cell in order to produce a given polarization. (See *Cell, Voltaic, Polarization of.*)

During the discharge of a voltaic cell an electromotive force is gradually set up that is opposed to that of the cell. The quantity of electricity required to produce a given polarization depends, of course, on the condition and size of the plates. Such a quantity is called the capacity of polarization.

Cell, Voltaic, Closed-Circuit — — A voltaic cell that can be left for a considerable time on a closed circuit of comparatively small resistance without serious polarization.

The term closed-circuit voltaic cell is used in contradistinction to open-circuit cell, and applies to a cell that can only be kept on closed circuit for a comparatively short time.

Daniell's cell and the gravity cell are closed-circuit cells. Leclanché's is an open-circuit cell.

Cell, Voltaic, Contact Theory of — — A theory which accounts for the production of difference of potential or electromotive force in the voltaic cell by the contact of the elements of the voltaic couple with one another by means of the electrolyte.

The mere contact of two dissimilar substances through the electrolyte will produce a difference of potential, but the cause of the current which a voltaic cell is able to maintain is the chemical potential energy which becomes kinetic during combination. (See *Cell, Voltaic, Series, Contact.*)

Most authorities explain the difference of potential produced by the contact of different metals by the fact that the metals are surrounded by air. They point out the fact that the order of the metals in the contact-series is almost identical with the order of their electrochemical power as deduced from their chemical equivalents, and their heat of combination with oxygen. It would appear, therefore, that the difference of potential between a metal and the air which surrounds it, is a measure of the tendency of the metal to become oxidized.

The origin of the electromotive force of a zinc-copper couple, in an electrolyte of hydrogen sulphate, is the superior affinity of the zinc for the oxygen, over that of the copper for the oxygen.

Cell, Voltaic, Creeping in — — The formation, by efflorescence, of salts on the sides of the porous cup of a voltaic cell, or on the walls of the vessel containing the electrolyte.

Paraffining the portions of the walls out of the liquid, or covering the surface of the liquid with a neutral oil, obviates much of this difficulty. (See *Efflorescence.*)

Cell, Voltaic, Daniell's — — A zinc-copper couple, the elements of which are immersed respectively in electrolytes of dilute sulphuric acid, and a saturated solution of copper sulphate.

In the form of Daniell's cell, shown in Fig. 106, the copper element is made in the form of a cylinder c, and is placed in a porous cell. The copper cylinder is provided with a wire basket near the top, filled with crystals of blue vitriol, or copper sulphate, so as to maintain the strength of the solution while the cell is in use. The zinc is in the shape of a cylinder and is placed so as to surround the porous cell. This cell gives a nearly constant electromotive force.

The constancy of action of Daniell's cell depends on the fact that for every molecule of sulphuric acid decomposed in the outer cell, an additional molecule of sulphuric acid is supplied by the decomposition of a molecule of copper sulphate in the inner cell. This will be better un-

derstood from the following reactions which take place, viz.:

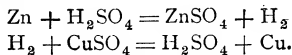

The H_2SO_4 , thus formed in the inner cell, passes through the porous cell, and the copper is deposited on the surface of the copper plate.

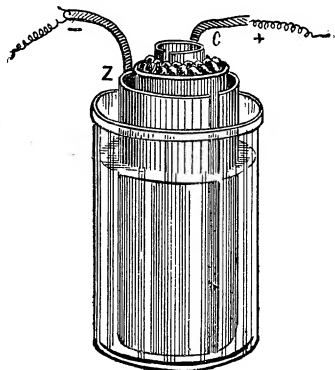

Fig 106. Daniell's Cell.

The Daniell cell gives an electromotive force of about 1.072 volts.

A serious objection to this form of cell arises from the fact that the copper is gradually deposited over the surface and in the pores of the porous cell, thus greatly increasing its resistance. This difficulty is avoided in the gravity cell. (See *Cell, Voltaic, Gravity.*)

Cell, Voltaic, Double-Fluid — — A voltaic cell in which two separate fluids or electrolytes are employed.

One of the elements of the voltaic couple is dipped into one of the fluids and the other element into the other fluid. In order to keep the fluids separate and distinct, they are either separated by means of porous cells, or by the action of gravity. (See *Cell, Porous, Cell, Voltaic, Gravity.*)

In the double-fluid cell the negative element is surrounded by a liquid which is capable of preventing polarization by combining chemically with the substance that tends to collect on its surface. In the Daniell cell this substance is the same as that of the negative plate. (See *Cell, Voltaic, Polarization of.*)

Cell, Voltaic, Dry — — A voltaic cell in which a moist material is used in place of the ordinary fluid electrolyte.

The term *dry cell* is in reality a misnomer, since all such cells are moistened with liquid electrolytes.

The dry cell, like other cells, is made in a variety of forms. The absence of free liquid permits the cell to be closed. A well known form of dry cell is shown in Fig. 107.

Cell, Voltaic, Effects of Capillarity in — — (See *Capillarity, Effects of, in Voltaic Cell.*)

Cell, Voltaic, Exciting Liquid of — — The electrolyte of a voltaic cell.

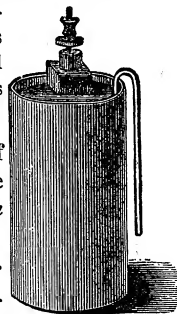

Fig. 107. Dry Cell.

A voltaic cell may have a single electrolyte, in which case it is called a single-fluid cell, or it may have two electrolytes, in which case it is called a double-fluid cell.

Cell, Voltaic, Fuller's Mercury Bichromate — — A zinc-carbon couple immersed in an electrolyte of electropositive liquid.

The zinc is attached to a copper rod by being cast thereto, and is placed at the bottom of a porous cell, where it is covered by a layer of mercury. The carbon plate is placed in electro-

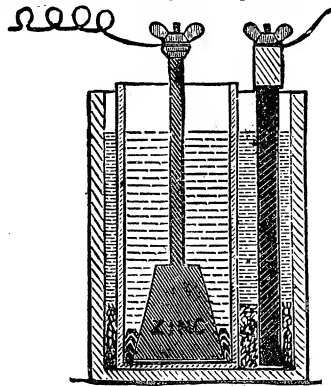

Fig. 108. Fuller's Mercury Bichromate Cell.

poison liquid. diluted with water in the proportion of three of the former to two of the latter. The zinc is generally placed in pure water, which rapidly becomes acid.

The mercury effects the continuous amalgamation of the zinc.

A Fuller mercury bichromate cell is shown in Fig. 108.

Cell, Voltaic, Gravity — —A zinc-copper couple, the elements of which are employed with electrolytes of dilute sulphuric acid or dilute zinc sulphate, and a concentrated solution of copper sulphate respectively.

The use of a porous cell is open to the objection of increased internal resistance. Moreover, the porous cell is apt to receive a coating of copper which often deposits on the cell instead of on the copper plate. The gravity cell was devised in order to avoid the use of a porous cell. As its name indicates, the two fluids are separated from each other by gravity.

The copper plate is the lower plate, and is surrounded by crystals of copper sulphate. The zinc, generally in the form of an open wheel, or crow-foot, is suspended near the top of the liquid, as shown in Fig. 109.

When the cell is set up with sulphuric acid, the reactions are the same as in the Daniell cell. When copper sulphate and zinc sulphate alone are used, zinc replaces the copper in the copper sulphate.

The action is then merely a substitution process. (See *Cell, Voltaic, Daniell's*.)

A dilute solution of zinc sulphate is generally used to replace the dilute sulphuric acid. It gives a somewhat lower electromotive force, but ensures a greater constancy for the cell.

Cell, Voltaic, Grenet — —A name sometimes given to the bichromate cell. (See *Cell, Voltaic, Bichromate*.)

Cell, Voltaic, Grove — —A zinc-platinum couple, the elements of which are used with electrolytes of sulphuric and nitric acids respectively.

The zinc, Z, Fig. 110, is amalgamated and placed in dilute sulphuric acid, and the platinum, P, in strong nitric acid (HNO₃) in a porous cell to separate it from the sulphuric acid. (See *Cell, Porous*.) In the Grove cell the current is moderately constant, since the polarization of the plati-

num plate is prevented by the nitric acid, which oxidizes and thus removes the hydrogen that tends to be liberated at its surface. The constancy of the current is not maintained for any considerable time, since the two liquids are rapidly decomposed, or consumed, zinc sulphate forming in the sulphuric acid, and water in the nitric acid.

The chemical reactions are as follows, viz.:

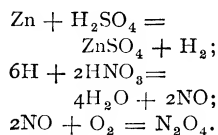

Nitrate of ammonium is sometimes formed when the nitric acid becomes dilute by decomposition. The reaction is as follows:

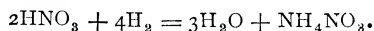

The cell gives an electromotive force of 1.93 volts.

When the porous cell is good, the resistance of the Grove cell may be calculated according to the following formula of Ayrton:

$$R = \frac{3.6 \times d}{A} \text{ ohms,}$$

where d, is the distance in inches between the platinum and zinc plates, and A, the square inches of the immersed portion of the platinum plate.

Cell, Voltaic, Leclanché — —A zinc-carbon couple, the elements of which are used in a solution of sal-ammoniac and a finely divided layer of black oxide of manganese respectively.

The zinc is in the form of a slender rod and dips into a saturated solution of *sal-ammoniac*, NH₄Cl.

The negative element consists of a plate of carbon, C, Fig. 111, placed in a porous cell, in which is a mixture of black oxide of manganese and broken gas-retort carbon, tightly packed around the carbon plate. By this means a greatly extended surface of carbon surrounded by black

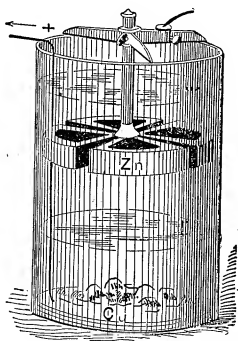

Fig. 109. The Gravity Cell.

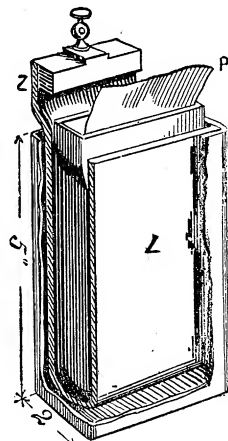

Fig. 110. Grove's Cell.

oxide of manganese, MnO_2 , is secured. The entire outer jar, and the spaces inside the porous cell are filled with the solution of sal-ammoniac.

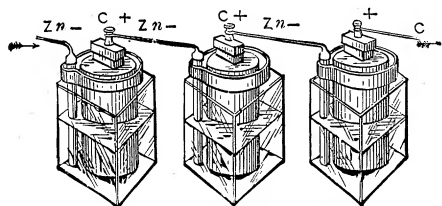
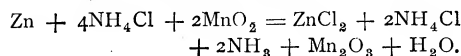

Fig. 111. The Leclanché Cell.

This cell, though containing but a single fluid, belongs, in reality, to the class or type of *double-fluid cells*, being one in which the negative element is surrounded by an oxidizing substance, the black oxide of manganese, which replaces the nitric acid or copper sulphate in the other double-fluid cells.

This reaction is generally given :



This reaction is denied by some, who believe the following to take place :

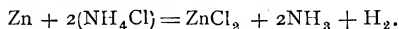

The $ZnCl_2$ and NH_3 react as follows :

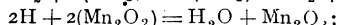
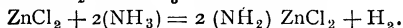

or, possibly, $4H + 3MnO_2 = Mn_2O + 2H_2O.$

The Leclanché cell gives an electromotive force of about 1.47 volts. It rapidly polarizes, and cannot, therefore, give a steady current for any prolonged time. When left on open circuit, however, it quickly depolarizes.

Cell, Voltaic, Local Action of — — (See *Action, Local, of Voltaic Cell.*)

Cell, Voltaic, Meidinger — — A zinc-copper couple, the elements of which are employed with dilute sulphuric acid, or solution of sulphate of magnesia, and strong nitric acid, respectively.

The Meidinger cell is a modification of the Daniell cell. The *zinc-copper* couple is thus arranged : Z Z, Fig. 112, is an amalgamated zinc ring placed near the walls of the vessel, A A, constricted at b b. The copper element, c, is similarly placed with respect to the walls of the vessel d d. The glass cylinder h, filled with

crystals of copper sulphate, has a small hole in its bottom, and keeps the vessel, d d, supplied with saturated solution of copper sulphate. The cell is charged with dilute sulphuric acid, or a dilute solution of Epsom salts, or magnesium sulphate.

Cell, Voltaic, Open-Circuit

— — A voltaic cell that cannot be kept on closed circuit, with a comparatively small resistance, for any considerable time without serious polarization.

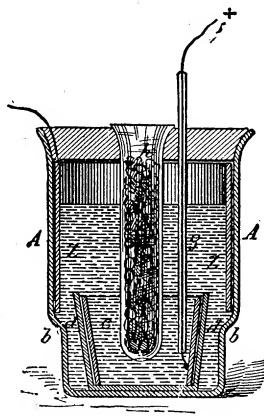

Fig. 112. The Meidinger Cell.

A Leclanché cell is an open-circuit cell. The term open-circuit cell is used in contradistinction to closed-circuit cell, such as the Daniell. (See *Cell, Voltaic, Closed-Circuit.*)

Cell, Voltaic, Poggendorff — — A name sometimes given to the Grenet cell. (See *Cell, Voltaic, Grenet.*)

Cell, Voltaic, Polarization of — — The collection of a gas, generally hydrogen, on the surface of the negative element of a voltaic cell.

The collection of a positive substance like hydrogen on the negative element or plate of a voltaic cell sets up a *counter-electromotive force*, which tends to produce a current in the opposite direction to that produced by the cell. (See *Force, Electromotive, Counter.*)

Polarization causes a decrease in the normal current of a voltaic cell:

(1.) On account of the *increased resistance* of the cell from the bubbles of gas which form part of its circuit.

(2.) On account of the *counter-electromotive force*, produced by polarization.

There are three ways in which the ill effects of the polarization of a voltaic cell can be avoided. These are :

(1.) *Mechanical.*—The negative plate is furnished with a roughened surface which enables the

bubbles of gas to escape from the points on such surface; or, a stream of gas, or air, is blown through the liquid against the plate and thus mechanically brushes the bubbles off.

(2.) *Chemical*.—The surface of the negative plate is surrounded by some powerful oxidizing substance, such as chromic or nitric acid, which is capable of oxidizing the hydrogen, and thus thoroughly removing it from the plate.

The oxidizing substance may form the entire electrolyte, as is the case of the bichromate solution employed in the zinc-carbon couple. Generally, however, it has been found preferable to employ a separate liquid, like nitric acid, to completely surround the negative plate, and another liquid for the positive plate, the two liquids being generally kept from mixing by a porous cell, or diaphragm. Such cells are called *double-fluid cells*. (See *Cell, Voltaic, Double-Fluid*.)

(3.) *Electro-Chemical*.—This also necessitates a double-fluid cell. The negative element is immersed in a solution of a salt of the same metal as that forming the negative plate. Thus, a copper plate, immersed in a solution of copper sulphate, cannot be polarized, since metallic copper is deposited on its surface by the action of the hydrogen which tends to be liberated there.

The constancy of action of a Daniell cell depends on a deposition of metallic copper on its copper plate as well as on the formation of hydrogen sulphate, and the solution of additional copper sulphate from the crystallized salt placed in the cell. (See *Cell, Voltaic, Daniell's*.)

Cell, Voltaic, Primary, Exhaustion of — — The inability of a primary voltaic cell to furnish any further current, unless fresh electrolyte, or fresh positive element, or both, are supplied to it.

In the case of exhaustion of a primary voltaic cell the stock of fresh energy is supplied to the cell from the chemical potential energy of the positive element, or of the electrolyte or electrolytes. (See *Energy, Chemical Potential*.)

In most voltaic cells a marked decrease in the current strength is observed soon after the circuit is closed, and, therefore, long before the cell is exhausted. This decrease is due—

(1.) To the increased internal resistance due to the bubbles of hydrogen on the negative plate.

(2.) To the counter-electromotive force of polarization, where zinc is employed with an electrolyte of sulphuric acid.

(3.) To the decrease in the electromotive force due to an increase in the density of the zinc sulphate.

Cell, Voltaic, Secondary, Exhaustion of — — The inability of a secondary cell to furnish any further current, unless fresh electro-positive and electro-negative materials are formed in it by the passage of the charging current.

In the case of the exhaustion of a secondary voltaic cell, the stock of fresh energy supplied to the cell is derived from the electric energy of the charging current. (See *Energy, Electric*.)

Cell, Voltaic, Siemens-Halske — — A zinc-copper couple, the elements of which are employed with dilute sulphuric acid and saturated solution of copper sulphate respectively.

The Siemens-Halske cell is a modification of Daniell's. A ring of zinc, Z Z, Fig. 113, sur-

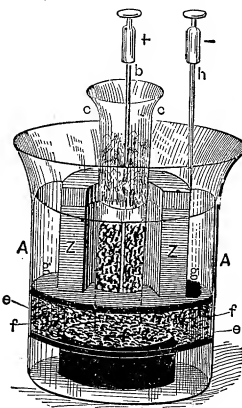

Fig. 113. Siemens-Halske Cell.

rounds the glass cylinder, c c. The porous cell is replaced by a diaphragm, ff, of porous paper, formed by the action of sulphuric acid on a mass of paper pulp. Crystals of copper sulphate are placed in the glass jar, c c, and rest on the copper plate, k, formed of a close copper spiral. Terminals are attached at b and h. The entire cell is charged with dilute sulphuric acid. The resistance of the cell is high.

Cell, Voltaic, Silver Chloride — — A zinc and silver couple immersed in electrolytes of sal-ammoniac or common salt and silver chloride.

The zinc acts as the positive element, and a silver wire, around which a cylinder of fused silver chloride is cast, as the negative element. The zinc, and the silver wire and silver chloride, are placed in a small glass test-tube and covered with the sal-ammoniac or common salt, and the tube closed by a cork of paraffin, to prevent the evaporation of the electrolyte. When sal-ammoniac is used, the strength of the solution is that obtained by dissolving 23 grammes of pure sal-ammoniac in 1 litre of water. The silver chloride acts as a depolarizer.

This cell is used as a standard cell, known as De la Rue's standard cell, from its inventor, Warren De la Rue. Its electromotive force is 1.068 volts.

Cell, Voltaic, Simple — —Any voltaic cell formed of a single couple immersed in a single exciting liquid.

Cell, Voltaic, Single-Fluid — —A voltaic cell in which but a single fluid or electrolyte is used.

Single-fluid voltaic cells possess the disadvantage of polarizing during action. This polarization is due to the electro-positive element of the electrolyte collecting on the surface of the negative plate, or within its mass. For example, where dilute sulphuric acid is the electrolyte, hydrogen gas collects on the negative plate and lowers the *electromotive force* produced by the cell, by a *counter-electromotive force* thereby generated. (See *Force, Electromotive. Force, Electromotive, Counter.*)

Cell, Voltaic, Smee — —A zinc-silver couple used with an electrolyte of dilute sulphuric acid, H_2SO_4 .

A form of Smee cell is shown in Fig. 114. Here the plate of silver is placed between two zinc plates.

The silver plate is roughened and covered with a coating of metallic platinum, in the condition known as *platinum black*. (See *Platinum Black.*) This cell was formerly extensively employed in *electro-metallurgy* but is now replaced by *dynamo-electric-machines*. (See *Metallurgy, Electro. Machine, Dynamo-Electric.*)

A *zinc-carbon* couple is sometimes used to replace the *zinc-silver* couple. A couple of *zinc-lead* is also used, though not very advantageously.

The Smee cell was one of the earliest forms of voltaic cells.

In the zinc-silver couple the chemical reaction that takes place when the cell is furnishing current is as follows, viz.:

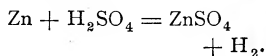

The Smee cell gives an electromotive force of about .65 volt.

Cell, Voltaic, Standard — —A voltaic cell the electromotive force of which is constant, and

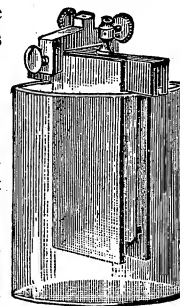

Fig. 114. Smee Cell.

which, therefore, may be used in the measurement of an unknown electromotive force.

Absolute constancy of electromotive force is impossible to attain, but if the current of the standard cell is closed but for a short time the electromotive force may be regarded as practically invariable.

Cell, Voltaic, Standard, Clark's — — The form of standard cell shown in Fig. 115.

Latimer Clark's standard cell assumes a variety of forms. The H-form is arranged as shown in Fig. 115. The vessel to the left contains, at A, an amalgam of pure zinc. The other vessel contains, at M, mercury covered with pure mercurous sulphate, $Hg_2 SO_4$. Both vessels are then filled, above the level of the cross tube, with a saturated solution of zinc sulphate Z, Z, to which a few crystals of the same are added. Tightly fitting corks C, C, prevent loss by evaporation.

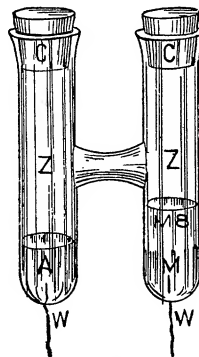

Fig. 115. Clark's Standard Cell.

The voltage of this cell in legal volts is 1.438 [1 - 0.00077 (t - 15 degrees C.)]—(Ayrton.)

The value t, is the temperature in degrees of the centigrade scale.

Cell, Voltaic, Standard, Rayleigh's Form of Clark's — —A modified form of Clark's cell.

Lord Rayleigh's form of Clark's standard cell is shown in Fig. 116. The electrodes pass respectively through the bottom and top of the test tube of glass. On the lower electrode a layer of mercury, Hg, is placed. On this rests a layer of mercurous sulphate paste made sufficiently semi-fluid with a solution of zinc sulphate to form an approximately level surface. The zinc, Zn, is attached to the upper electrode and is immersed in this semi-fluid paste.

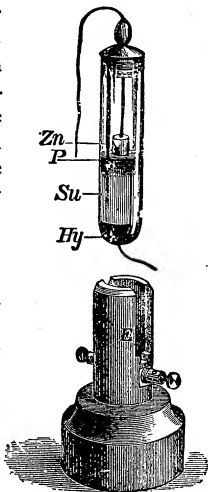

Fig. 116. Rayleigh's Form of Clark's Standard Cell.

The mercurous sulphate appears to act to keep the mercury free from impurities.

The electromotive force of this cell has been carefully determined by Rayleigh. Its value in true volts is :

$$E = 1.435 [1 - .00077 (t - 15)]$$

when t, is the temperature in degrees Centigrade.

This cell is often called Clark's normal element.

Cell, Voltaic, Standard, De la Rue's — —
—A form of silver-chloride cell. (See *Cell, Voltaic, Silver-Chloride.*)

Cell, Voltaic, Standard, Fleming's — —

The form of standard cell shown in Fig. 117.

The U-tube, Fig. 117, is connected, as shown, by means of taps, with two vessels filled with chemically pure solutions of copper sulphate of sp. gr. 1.1 at 15 degrees C., and zinc sulphate of sp. gr. 1.4 at 15 degrees C. respectively. To use the cell the zinc rod Zn, connected with a wire passing through a rubber stopper, is placed in the left-hand branch. The tap A, is opened and the entire U-tube is filled with the denser zinc sulphate solution. The tap at C, is then

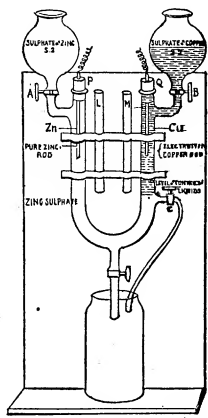

Fig. 117. Fleming's Standard Cell.

opened, and the liquid in the right-hand branch above the tap is discharged into the lower vessel, but, from this part only. The tap C, is then closed, and the tap B, opened, and the lighter copper sulphate allowed to fill the right-hand branch above the tap C. The copper rod Cu, fitted to a rubber stopper and connected with a conducting wire, is then placed in the copper solution.

Tubes are provided at L and M, for the reception of the zinc and copper rods when not in use. The copper rod is prepared for use by freshly electro-plating it with copper. The electromotive force of this cell is 1.074 volts. If the line of demarkation between the two liquids is not sharp, the arms of the vessels are emptied, and fresh liquid is run in.

Cell, Voltaic, Standard, Lodge's — —
—A form of standard Daniell cell.

Lodge's standard cell is shown in Fig. 118. Through the tube T, in a wide mouthed bottle, is passed the glass tube, in the mouth of which is placed a zinc rod. To the bottom of the tube T, a small test-tube t, containing crystals of copper sulphate, is fastened by means of a string or rubber band. The uncovered end of a gutta-percha insulated copper wire projects at the bottom of t, through a tube in a tightly fitting cork, and forms the copper electrode. The bottle is partly filled as shown with a solution of zinc sulphate.

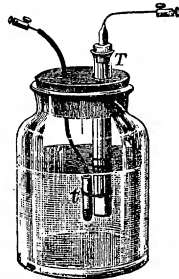

Fig. 118. Lodge's Form of Daniell's Cell.

The internal resistance of this cell is so high that it is only employed in the use of zero methods with a condenser.

Cell, Voltaic, Standard, Sir William Thomson's — —
—A form of standard Daniell cell.

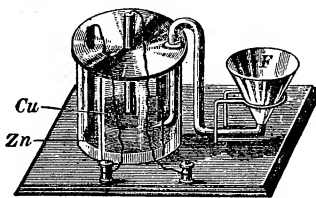

Fig. 119. Thomson's Form of Daniell's Cell.

Sir Wm. Thomson's standard cell is shown in Fig. 119. A zinc disc is placed at the bottom of the

cylindrical vessel and a solution of zinc sulphate of sp. gr. 1.2 poured over it. By means of the funnel F, a half-saturated solution of copper sulphate is carefully poured over this and floats on it owing to its smaller density. The electromotive force of this cell is 1.072 true volts at 15 degrees C.

Cell, Voltaic, Standardizing a — — Determining the exact value of the electromotive force of a voltaic cell, in order to enable it to be used as a standard in determining the electromotive force of any other electric source.

Cell, Voltaic, Two-Fluid — — A term sometimes employed in place of double-fluid cell. (See *Cell, Voltaic, Double-Fluid*.)

Cell, Voltaic, Water — — A voltaic cell in which the exciting liquid is merely water.

Any voltaic couple can be used, the positive element of which is acted on by water. (See *Battery, Voltaic*.)

Cell, Voltaic, Zinc-Carbon — — A cell in which zinc and carbon form the positive and negative elements respectively.

A name sometimes given to the bichromate cell.

Cell, Voltaic, Zinc-Copper — — A cell in which zinc and copper form the positive and negative elements respectively.

Cell, Voltaic, Zinc-Lead — — A zinc-lead couple sometimes used, though not very advantageously, to replace the zinc-silver couple in a Smee cell. (See *Cell, Voltaic, Smee*.)

Cells, Coupled — — A number of separate cells connected in any way so as to form a single source.

Cells, Voltaic, Series-Connected — — A number of separate voltaic cells connected in series so as to form a single source. (See *Circuit, Series*.)

Cement-Lined Conduit. — (See *Conduit, Cement-Lined*.)

Cements, Insulating — — Various mixtures of gums, resins and other substances, possessing the ability to bind two or more

substances together and yet to electrically insulate one from the other.

Centi. — (As a prefix) — The one-hundredth part of.

Centi-Ampère. — One-hundredth of an ampère.

Centi-Ampère Balance. — (See *Balance, Centi-Ampère*.)

Centigrade Thermometer Scale. — (See *Scale, Centigrade Thermometer*.)

Centigramme. — The hundredth of a gramme

One centigramme equals 0.1544 grains avoirdupoise. (See *Weights and Measures, Metric System of*.)

Centilitre. — The hundredth of a litre.

One centilitre equals 0.6102 of a cubic inch. (See *Weights and Measures, Metric System of*.)

Centimetre. — The hundredth of a metre.

One centimetre equals 0.3937 inch. (See *Weights and Measures, Metric System of*.)

Centimetre-Gramme-Second Units. — (See *Units, Centimetre-Gramme-Second*.)

Central Galvanization. — (See *Galvanization, Central*.)

Central Station. — (See *Station, Central*.)

Central Station Burglar Alarm. — (See *Alarm, Burglar, Central Station*.)

Central Station Lighting. — (See *Lighting, Electric Central Station*.)

Centre of Gravity. — (See *Gravity, Centre of*.)

Centre of Oscillation. — (See *Oscillation, Centre of*.)

Centre of Percussion. — (See *Percussion, Centre of*.)

Centrifugal Force. — (See *Force, Centrifugal*.)

Centrifugal Governor. — (See *Governor, Centrifugal*.)

Chain Lightning. — (See *Lightning, Chain*.)

Chain, Linked Magnetic and Electric — — A chain of three links, the separate links of which consist of the primary circuit,

the magnetic circuit, and the secondary circuit respectively, of an induction coil.

The conception of a linked magnetic and electric chain, in studying the action of an induction coil, was first developed by Kapp. A linked magnetic and electric chain is shown in Fig. 120.

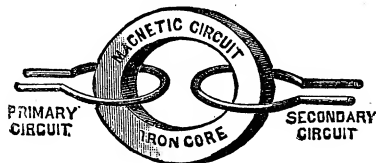

Fig. 120. Linked Magnetic and Electric Chain.

If, in such a case, the magnetic core or circuit is of varying magnetization, when one of the electric circuits has a periodic current passed through it, the various phenomena of the induction coil are produced. (See *Coil, Induction*.)

Chain, Molecular — — A polarized chain of molecules that is supposed to exist in an electrolyte during its electrolytic decomposition, or in a voltaic cell on closing its circuit. (See *Hypothesis, Grotthus*.)

Chain Pull.—(See *Pull, Chain*.)

Chamber, Armature — — The armature bore. (See *Bore, Armature*.)

Chamber of Lamp.—(See *Lamp, Chamber of*.)

Change, Chemical — — Any change in matter resulting from atomic combination and the consequent formation of new molecules.

Some chemical changes are caused by atomic combinations and the formation of new molecules. They are necessarily attended by a loss of the specific identity of the substances involved in the change. Thus carbon, a black solid, combined with sulphur, a yellow solid, produces carbon disulphide, a colorless, odorous liquid. (See *Atom*.)

Change, Physical — — Any change in matter resulting from a change in the relative position of its molecules, without the formation of new molecules.

Ice, when heated, is turned into water; steel, when stroked by a magnet, is rendered permanently magnetic; a piece of vulcanite or hard

rubber stroked by a piece of cat skin becomes electrified. In all these cases, which are instances of physical changes, the substances retain their specific identity. This is true in all cases of physical changes. (See *Molecule*.)

Changing-over Switch.—(See *Switch, Changing-over*.)

Changing Switch.—(See *Switch, Changing*.)

Characteristic Curve.—(See *Curve, Characteristic*.)

Characteristic Curve of Parallel Transformer.—(See *Curve, Characteristic, of Parallel Transformer*.)

Characteristic Curve of Series Transformer.—(See *Curve, Characteristic, of Series Transformer*.)

Characteristics of Sound.—(See *Sound, Characteristic of*.)

Charge, Bound — — The condition of an electric charge on a conductor placed near another conductor, but separated from it by a medium through which electrostatic induction can take place. (See *Induction, Electrostatic*.)

When a charged conductor is placed near another conductor, but separated from it by a dielectric or medium through which induction can take place, a charge of the opposite name is induced in the neighboring conductor. This charge is so held or bound on the conductor by the mutual attraction of the opposite charge that it is not discharged on connection with the earth unless both conductors are simultaneously touched by any good conductor. The bound charge was formerly called *dissimulated* or *latent electricity*. (See *Electricity, Dissimulated or Latent*.)

Charge, Density of — — The quantity of electricity per unit of area at any point on a charged surface.

Coulomb used the phrase *surface density* to mean the quantity of electricity per unit of area at any point on a surface.

Charge, Dissipation of — — The gradual but final loss of any charge by leakage, which occurs even in a well insulated conductor.

This loss is more rapid with negatively charged conductors, than with those positively charged.

Crookes, of England, has retained a charge on conductors for years, without appreciable leakage, by placing the conductors in vessels in which a *high vacuum* was maintained. (See *Vacuum, High.*)

Charge, Distribution of — —The variations that exist in the density of an electrical charge at different portions of the surface of all insulated conductors except spheres.

The density of charge varies at different points of the surface of conductors of various shapes. It is uniform at all points on the surface of a sphere.

It is greater at the extremities of the longer axis of an egg-shaped body, and greatest at the sharper end.

It is greater at the corners of a cube than at the middle of a side.

It is greatest around the edge of a circular disc.

It is greatest at the apex of a cone

Charge, Electric — —The quantity of electricity that exists on the surface of an insulated electrified conductor.

When such a conductor is touched by a good conductor connected with the earth, it is *discharged*. (See *Condenser.*)

Charge, Free — —The condition of an electric charge on a conductor isolated from any other conductor.

It is impossible to obtain a perfectly free charge, since it is impossible to completely isolate an insulated conductor. The charge, however, can be comparatively free.

The charge, on a completely isolated conductor, readily leaves it when it is put in contact with a good conductor connected with the ground. (See *Charge, Bound.*)

Charge, Induced Electrostatic — —The charge produced by bringing a body into an electrostatic field.

In order to obtain a permanent charge, *i. e.*, a charge which will be maintained when the body is withdrawn from an electrostatic field, it is necessary to connect the body with the earth so that it may lose, or part with, a charge of the same name as the inducing charge. Then, on the withdrawal of this charge, it will possess a charge opposite in name to the inducing charge. (See *Condenser.*)

Charge, Influence — —A charge pro-

duced by electrostatic induction. (See *Induction, Electrostatic.*)

Charge, Negative — —According to the double-fluid hypothesis, a charge of negative electricity.

According to the single-fluid hypothesis, any deficit of an assumed electrical fluid.

Charge, Positive — —According to the double-fluid hypothesis, a charge of positive electricity.

According to the single-fluid hypothesis, any excess of an assumed electrical fluid.

Charge, Residual — —The charge possessed by a charged Leyden jar for a few moments after it has been disruptively discharged by the connection of its opposite coatings.

The residual charge is probably due to a species of *dielectric strain*, or a strained position of the molecules of the glass caused by the charge. Such residual charge is not present in air condensers. In other words, a Leyden jar does not give up all the electric energy charged in it, on a single disruptive discharge.

Charge, Return — —A charge induced in neighboring conductors by a discharge of lightning.

Under the influence of induction a lightning stroke produces during its discharge an electric shock in the human body, or a charge in neighboring bodies, which is called the back or return stroke of lightning. (See *Stroke, Lightning, Back or Return.*)

Charged Body.—(See *Body, Charged.*)

Charging Accumulators.—Sending an electric current into a storage battery for the purpose of rendering it an electric source.

There is, strictly speaking, no accumulation of electricity in a storage battery, such, for example, as takes place in a condenser, but a mere storage of chemical energy, which may afterward become electric. (See *Cell, Storage.*)

Charging Leyden Jars by Cascade.—(See *Cascade, Charging Leyden Jars by.*)

Chart, Inclination — —A map or chart on which the isoclinic lines are marked. (See *Map or Chart, Inclination. Lines. Isoclinic.*)

Chart, Isodynamic — —A map or chart on which the isodynamic lines are marked. (See *Map or Chart, Isodynamic. Lines, Isodynamic.*)

Chart, Isogonal — —An isogonic chart. (See *Map or Chart, Isogonal.*)

Chart, Isogonic — —A map or chart on which the isogonic lines are marked. (See *Map or Chart, Isogonic. Lines, Isogonic.*)

Chatterton's Compound. — (See *Compound, Chatterton's.*)

Chemical Change.—(See *Change, Chemical.*)

Chemical Effect.—(See *Effect, Chemical.*)

Chemical Equivalent.—(See *Equivalent, Chemical.*)

Chemical Galvano-Cautery.—(See *Cautery, Galvano-Chemical.*)

Chemical Phosphorescence.—(See *Phosphorescence, Chemical.*)

Chemical Photometer.—(See *Photometer, Chemical.*)

Chemical Potential Energy.—(See *Energy, Chemical Potential.*)

Chemical Recorder, Bain's — —(See *Recorder, Chemical, Bain's.*)

Chemistry, Electro — —That branch of electric science which treats of chemical compositions and decompositions effected by the electric current. (See *Electrolysis. Decomposition, Electrolytic.*)

That branch of chemistry which treats of combinations and decompositions by means of electricity.

Electro-chemistry treats of the formation of new molecules, by the combination of atoms under the electric force, as well as the decomposition of molecules by electricity.

The action of a series of sparks passed through air, in forming nitric acid, is an instance of the former, and electrolytic decompositions in general afford instances of the latter.

Chimes, Electric — —Bells rung by the attractions and repulsions of electrostatic charges.

The bells B and B, Fig. 121, are conductively connected to the *prime* or *positive* conductor +,

of a frictional machine. The bell C, is insulated from this conductor by means of a silk thread, but is connected with the ground by the metallic chain. Under these circumstances the clappers, l, l, insulated by silk threads, t, t, are attracted to B, B, by an induced charge and repelled to C, where they lose their charge only to be again attracted to B, B. In this way the bells will continue ringing as long as the electric machine is in operation.

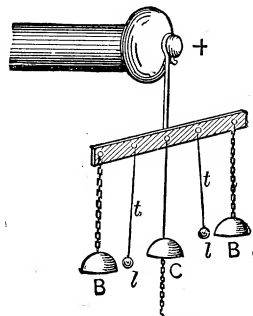

Fig. 121. Electric Chimes.

Choking Coil.—(See *Coil, Choking.*)

Chronograph, Electric — —An electric apparatus for automatically measuring and registering small intervals of time.

Chronographs, though of a variety of forms, generally register small intervals of time by causing a tuning fork or vibrating bar of steel, whose rate of motion is accurately known, to trace a sinuous line on a smoke-blackened sheet of paper, placed on a cylinder driven at a uniform rate of motion by clockwork. If the fork is known to produce, say, 256 vibrations per second be used, each sinuous line will represent $\frac{1}{256}$ part of a second.

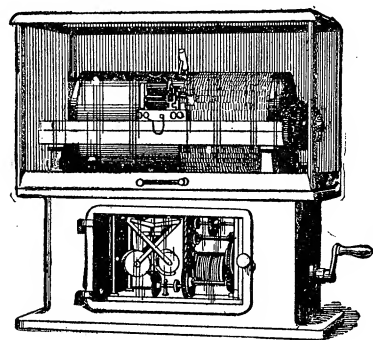

Fig. 122. Electric Chronograph.

An electro-magnet is used to make marks on the line at the beginning and the end of the observation, and thus permit its duration to be measured.

In the form of electric chronograph shown

in Fig. 122, an electro-magnet, the armature of which carries a pen, is supported on a carriage moved by clockwork over a sheet of paper wrapped on a rotating cylinder. A clock is so connected with the circuit of the electro-magnet that it makes or breaks the circuit at the end of every second second, and so moves, or displaces, the armature, as to cause an elevation or depression in the otherwise continuous sinuous line, that would be drawn on the paper by the double motion of its rotation and the movement of the pen-carriage.

When it is desired to know with great precision the exact time of occurrence of any event, such, for example, as the transit of a star over the meridian, the observer, who carries in his hand a push button, or other form of electric key, closes or opens the circuit at the exact moment and so superposes an additional mark on the sinuous line. Since the exact time of starting the clock is known, and the intervals between the regular successive marks are two seconds each, it is easy to estimate from its position between any two such marks the exact value of the additional mark interposed. Fig. 122, taken from Young, shows a form of chronograph by Warner & Swasey. The details of this apparatus will be understood from an inspection of the drawing.

Chronograph Record.—(See *Record, Chronograph.*)

Chronoscope, Electric — —An apparatus for electrically indicating, but not necessarily recording, small intervals of time.

This term is often used for chronograph.

The interval of time required for a rifle ball to pass between two points may be determined by causing the ball to pierce two wire screens placed a known distance apart. As the screens are successively pierced, an electric circuit is thus made or broken, and marks are registered electrically on any apparatus moving with a known velocity.

Cigar-Lighter, Electric — —(See *Lighter, Cigar, Electric.*)

Cipher Code.—(See *Code, Cipher.*)

Circle, Azimuth — —The arc of a great circle passing through the point of the heavens directly overhead, called the Zenith, and the point directly beneath, called the Nadir.

Circle, Dipping — —A term sometimes applied to an inclination compass. (See *Compass, Inclination.*)

Circle, Galvanic — —A term sometimes used for galvanic circuit. (See *Circuit, Galvanic.*)

Circle of Reference.—The circle, by reference to which simple harmonic motion may be studied, by comparison with uniform motion around such circuit. (See *Motion, Simple Harmonic.*)

Circle, Voltaic — —A name formerly employed for voltaic cell or circuit. (See *Cell, Voltaic. Circuit, Voltaic.*)

Circuit, Air-Magnetic — —That part of the path of a line of magnetic induction which takes place wholly through air.

Circuit, Alternating Current — —A circuit in which an alternating current of electricity is flowing. (See *Current, Alternating.*)

Circuit, Astatic — —A circuit consisting of two closed curves enclosing equal surfaces.

Such a circuit is not deflected by the action of the earth's field. The circuit disposed, as shown in Fig. 123, is astatic and produces two equal and opposite fields at S and S'. (See *Mag. Fig. 123. Astatic Circuit. netism, Ampère's Theory of.*)

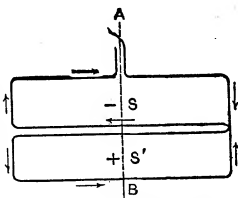

Circuit, Balanced-Metallic — —A metallic circuit, the two sides of which have similar electrical properties.

Circuit Breaker.—(See *Breaker, Circuit.*)

Circuit, Broken — —An open circuit. A circuit, the electrical continuity of which has been disturbed, and through which the current has therefore ceased to pass.

Circuit, Closed — —A circuit is closed, completed, or made when its conducting continuity is such that the current can pass.

Circuit, Closed Iron-Magnetic — —The name applied to the path of any line

of magnetic force, which takes place entirely through iron, steel, or other paramagnetic substance.

Circuit, Closed-Loop Parallel — — A variety of parallel circuit in which the lead and the return circuit are arranged in the form of concentric circuits, with the receptive devices placed radially between them.

Circuit, Closed-Magnetic — — A magnetic circuit which lies wholly in iron or other substance of high magnetic permeability.

All lines of magnetic force form closed circuits. The term closed-magnetic circuit is used in contradistinction to a divided circuit, or one in which an air gap exists in the substance of high mag-

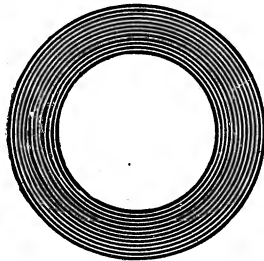

Fig. 124. Closed-Magnetic Circuit.

netic permeability forming the remainder of the circuit. This introduces so high a resistance that such a circuit is sometimes called an open-magnetic circuit. An iron ring, such as shown in Fig. 124, forms a closed-magnetic circuit.

Circuit, Closed-Magnetic, of Atom — — A closed-magnetic circuit, or closed lines of magnetic force supposed to lie entirely in the atom itself.

The assumption of closed lines of magnetic force in atoms or molecules was made in order to explain the original polarity of the same, and to account for some of the other phenomena of magnetism.

When the atom is subjected to a magnetizing force, such, for example, as the field of an electric current, these closed lines of force are assumed to open out and produce lines of polarized atoms. According to Lodge, for every single line of force produced by the current passing through a coil of wire surrounding an iron core, some 3,000 lines of magnetic force are added to it from the iron. Therefore an iron core greatly increases the magnetic strength of a hollow coil of wire.

Circuit, Closed-Magnetic, of Molecule — — A closed-magnetic circuit assumed to lie wholly within the molecule.

As it is not known whether the assumed magnetic circuit lies within the atom or the molecule, it is called indifferently the closed-atomic or closed-molecular circuit. (See *Circuit, Closed-Magnetic, of Atom.*)

Circuit, Completed — — A closed circuit.

A circuit, the conducting continuity of which is unbroken.

A completed circuit is also called a made or closed circuit.

Circuit, Compound — — A circuit containing more than a single source, or more than a single electro-receptive device, or both, connected by conducting wires.

The term compound circuit is sometimes applied to a *series circuit*. (See *Circuit, Series.*) The term, however, is a bad one, and is not generally adopted.

Circuit, Constant-Current — — A circuit in which the current or number of amperes is maintained constant notwithstanding changes occurring in its resistance.

The series-circuit, as maintained for arc-lamps, is a constant-current circuit. (See *Regulation, Automatic.*)

Circuit, Constant-Potential — — A circuit, the potential or number of volts of which is maintained approximately constant.

The multiple-arc or parallel circuit is an approximately constant-potential circuit.

Circuit, Derivative — — A derived or shunt circuit. (See *Circuit, Shunt.*)

Circuit, Derived — — A term applied to a shunt circuit.

If, in addition to the galvanometer G, the conductor S, Fig. 125, be connected with the circuit of the battery B, a derived circuit will thus be established, and a current will flow through S, diminishing the current in the galvanometer. (See *Circuit, Shunt.*)

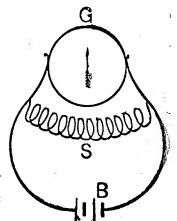

Fig. 125. Derived Circuit.

Circuit, Divided-Magnetic — —A magnetic circuit which lies partly in iron, or other substance of high magnetic permeability, and partly in air.

A divided-magnetic circuit is shown in Fig. 126.

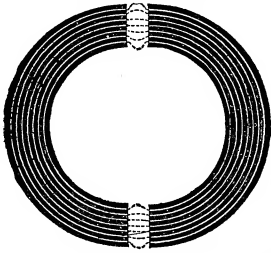

Fig. 126. Divided Magnetic Circuit.

Where the iron ring is separated by the air gap, a high magnetic resistance is introduced, owing to the fact that the iron is at these points replaced by air, whose magnetic reluctance is great.

Circuit, Double-Wire — —A term sometimes used for a simple multiple circuit with two conductors or wires. (See *Circuit, Multiple*.)

The term double-wire circuit is used in contradistinction to *single-wire* circuit. (See *Circuit, Single-Wire*.)

Circuit, Earth — —A circuit in which the ground or earth forms part of the conducting path.

Circuit, Earth, Telegraphic — — That portion of a telegraphic circuit which is completed through the earth or ground.

Circuit, Electric — —The path in which electricity circulates or passes from a given point, around or through a conducting path, back again to its starting point.

All simple circuits consist of the following parts, viz.:

- (1.) Of an electric source which may be a *voltaic battery*, a *thermopile*, a *dynamo-electric machine*, or any other means for producing electricity.
- (2.) Of *leads* or *conductors* for carrying the electricity out from the source, through whatever apparatus is placed in the line, and back again to the source.
- (3.) Various *electro-receptive devices*, such as electro-magnets, electrolytic baths, electric motors, electric heaters, etc., through which

passes the current by which they are actuated or operated.

Circuit, Electrostatic — —The circuit formed by lines of electrostatic force.

Lines of electrostatic force, like lines of magnetic force, form closed circuits. Hence the origin of the phrase *electrostatic circuit*. (See *Force, Electrostatic, Lines of*.)

Circuit, External — —That part of a circuit which is external to, or outside the electric source.

The circuit external to the source consists of two distinct parts, viz.:

- (1.) The conductors or leads.
- (2.) The electro-receptive or translating devices.

It is in the external circuit only that useful work is done by the current.

Circuit, Forked — —A term sometimes used in telegraphy for a number of circuits that radiate from a given central point.

Circuit, Galvanic — —A term sometimes employed instead of voltaic circuit.

The term galvanic in place of voltaic is unwarranted by the facts of electric science. (See *Circuit, Voltaic*.)

Galvani thought he had discovered the vital fluid or source of animal life. Volta first pointed out the true explanation of the phenomena observed in Galvani's frog, and devised means for producing electricity in this manner. The terms *voltaic battery*, *cell*, *circuit*, etc., are therefore preferable.

Circuit, Ground — —A circuit in which the ground forms part of the path through which the current passes.

As the ground is not always a good conductor, the terminals should be connected with the gas or water pipes, or with metallic plates, called *ground plates*. Such connection, or any similar ground connection, is usually termed the ground or earth.

Circuit, Ground, Telegraphic — — An earth circuit used in any system of telegraphy. (See *Circuit, Earth, Telegraphic*.)

Circuit, Grounded — —A ground circuit.

Circuit, Incomplete — —An open or broken circuit.

A circuit whose conducting continuity is incomplete.

Circuit, Inductive — — Any circuit in which induction takes place.

Circuit, Internal — — That part of a circuit which is included within the electric source.

The electric current passing through the internal circuit does no useful work.

Circuit, Leg of — — One part of a twisted or metallic circuit.

Circuit, Line — — The wire or other conductors in the main line of any telegraphic or other electric circuit.

Circuit, Line, Telegraphic — — The conductor or line connecting different telegraphic stations.

Circuit, Local-Battery — — The circuit, in a telegraphic system, in which is placed a local battery as distinguished from a main battery. (See *Telegraphy, American or Morse System of.*)

Circuit, Loop — — A term sometimes applied to a circuit in parallel or multiple-arc. (See *Circuit, Multiple.*)

Circuit Loop Break. — (See *Break, Circuit Loop.*)

Circuit, Made — — A completed circuit.

A circuit, whose conducting continuity is unbroken.

A made circuit is often called a completed or closed circuit. (See *Circuit, Closed.*)

Circuit, Magnetic — — The path through which the lines of magnetic force pass.

All lines of magnetic force form closed circuits.

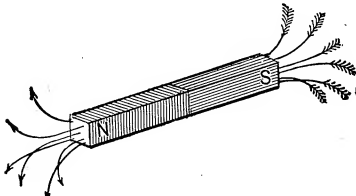

Fig. 127. Magnetic Circuit.

In the bar magnet, shown in Fig. 127, part of this path is through the air. In order to reduce or lower the *resistance* of a magnetic circuit, iron

is often placed around the magnet. The magnet is then said to be *iron-clad*.

The armature of a magnet lowers the magnetic resistance by affording a better path for the lines of magnetic force than the air between the poles.

The magnetic circuit always tries to shorten its path, or to render itself as compact as possible. This is seen in the action of an armature drawn towards a magnet pole.

Circuit, Main-Battery — — A term sometimes used for line circuit. (See *Circuit, Line.*)

Circuit, Metallic — — A circuit in which the ground is not employed as any part of the path of the current, metallic conductors being employed throughout the entire circuit.

Circuit, Multiple — — A compound circuit, in which a number of separate sources or separate electro-receptive devices, or both, have all their positive poles connected to a single positive lead or conductor, and all their negative poles to a single negative lead or conductor.

The connection of three Bunsen cells, in multiple, is shown in Fig. 128, where the three car-

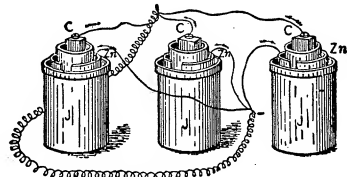

Fig. 128. Batteries connected in a Multiple Circuit.

bons, C, C, C, are connected together so as to form the positive, or + terminal of the battery, and the three zincs, Zn, Zn, Zn, are similarly connected together so as to form the negative, or — terminal.

The electromotive force is the same as that of a single cell, or source. The internal resistance of the source is as much less than the resistance of any single source as the area of the combined negative or positive plates is greater than that of any single negative or positive plate; or, in other words, is less in proportion to the number of cells, or other separate sources so coupled.

The connection of six cells in multiple or parallel circuit, is shown in Fig. 129.

In the case of the six cells, the current would be,

$$C = \frac{E}{\frac{r}{6} + r'}$$

where E, is the electromotive force, r, the internal, and r', the external resistance.

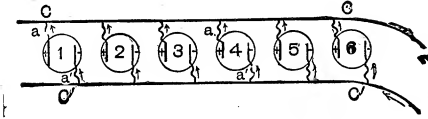

Fig. 129. Six Cells Connected in Multiple.

In the case of voltaic cells the effect of multiple connection on the internal resistance of the source is to increase the area of cross-section of the liquid in the direct proportion of the number of cells added, and consequently to decrease the resistance in the same proportion.

When strong or large currents of low electromotive force are required, connections in multiple-arc are generally employed.

The multiple-arc connection was formerly called *connection-for-quantity*. This term is now abandoned.

The total resistance for the parallel circuit is obtained as follows: calling the separate resistances of the separate electro-receptive devices, R', R'', R''', etc., etc., total resistance,

$$R = \frac{R' \times R'' \times R'''}{R' R'' + R'' R''' + R' R'''}$$

or, what is the same thing, the conductivity is the sum of the reciprocal of the separate resistances, *i. e.:*

$$\text{Conductivity} = \frac{1}{R'} + \frac{1}{R''} + \frac{1}{R'''}$$

The joint resistance of only two separate resistances joined in a multiple-circuit is equal to the product of the separate resistances divided by their sum.

When the separate resistances joined in multiple arc are all of the same value, the joint resistance is equal to the resistance of one of them divided by their number.

Circuit, Multiple-Arc — — A term often used for multiple circuit. (See *Circuit, Multiple*.)

Circuit, Multiple-Series — — A compound circuit in which a number of separate

sources, or separate electro-receptive devices, or both, are connected in a number of separate groups in series, and these separate groups subsequently connected in multiple.

In Fig. 130, a multiple-series circuit of six

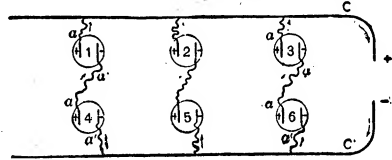

Fig. 130. Multiple-Series-Connected Cells.

sources is shown, in which three separate groups of two series-connected cells are coupled in multiple. The current takes the paths indicated by the arrows. The electromotive force of the source will be increased in proportion to the number of cells in series, and the internal resistance decreased in proportion to the number in parallel.

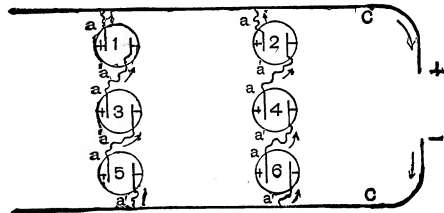

Fig. 131. Cells Connected in Multiple-Series.

$$C = \frac{3E}{\frac{3r}{2} + r'}$$

In Fig. 131, six cells are arranged in two groups of three series-connected cells, and these three groups connected in parallel.

Calling r, the resistance of each separate cell, the total resistance for the multiple-series circuit for a circuit containing three cells in parallel and two in series is,

$$R = \frac{2r}{3}$$

for three in series and two in parallel,

$$R = \frac{3r}{2}$$

If, therefore, the circuit of this battery be closed by a resistance equal to r, the current would be in the case of Fig. 130,

$$C = \frac{2E}{\frac{2r}{3} + r'}$$

Circuit, Negative Side of — —The side of a circuit opposite to the positive side. (See *Circuit, Positive Side of*.)

That side or half of a circuit connected to or leading from the positive terminal of the source of current.

Circuit, Open — —A broken circuit.

A circuit, the conducting continuity of which is broken.

Circuit, Open-Iron Magnetic — —

The path of a line of magnetic induction, which passes partly through iron, and partly through an air space.

The magnetic circuit is always closed, that is the lines of magnetic force always form closed paths. The term "open" is used in contradistinction only to "closed" iron magnetic circuit, in which the entire path of a line of force passes through iron. (See *Circuit, Magnetic*.)

Circuit, Parallel — —A name sometimes applied to circuits connected in multiple. (See *Circuit, Multiple*.)

Circuit, Parallel-Tree — —A form of parallel circuit in which the receptive devices are placed in parallel between the leads and returns, and the branches and sub-branches arranged in a tree-like form.

Circuit, Positive Side of — —That side of a circuit, bent in the form of a circle, in which, if an observer stood with his head in the positive region, he would see the current pass round him from his right hand towards his left.—(*Daniell*.)

Circuit, Recoil — —A term sometimes applied to the circuit that lies in the alternative path of a discharge. (See *Path, Alternative*.)

Circuit, Return — —That part of a circuit by which the electric current returns to the source.

In a multiple-circuit the lead that is connected to the negative terminals of the separate sources.

Circuit, Series — —A compound circuit in which the separate sources, or the separate electro-receptive devices, or both, are so placed that the current produced in each, or passed through each, passes successively

through the entire circuit from the first to the last.

The six cells, shown in Fig. 132, are connected in series by joining the positive pole of each cell with the negative pole of the succeeding cell, the negative and positive poles at the extreme ends

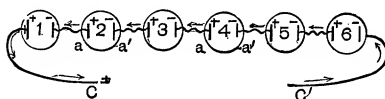

Fig. 132. Series Circuit.

being connected by conductors with the external circuit.

The connection of three Leclanché cells in series is clearly shown in Fig. 133. The carbons,

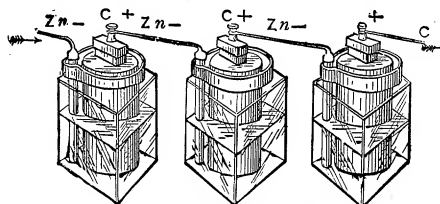

Fig. 133. Voltaic Cells Connected in Series.

C, C, of the first and second cells are connected to the zincs, Zn, Zn, of the second and third cells, thus leaving the zinc, Zn, of the first cell, and the carbon, C, of the third cell, as the terminals of the battery. The direction of the current is shown by the arrows.

The resistance of such a connection is equal to the sum of the resistances of all of the separate sources.

The electromotive force is equal to the sum of the separate electromotive forces.

If the electromotive force of a single cell is equal to E , its internal resistance to r , and the resistance of the leads and electro-receptive devices to r' , then the current in the circuit,

$$C = \frac{E}{r + r'}$$

If six of such cells are coupled in series, the current becomes

$$C = \frac{6E}{6r + r'}$$

If, however, the internal resistance of each cell be so small as to be neglected, the formula becomes

$$C = \frac{6E}{r'}$$

or the current is six times as great as with one cell.

The total resistance of the separate sources or electro-receptive devices of the series circuit is as follows, calling R' , R'' , R''' , etc., the separate resistance and R , the total resistance,

$$R = R' + R'' + R''', \text{ etc.}$$

The series connection of battery cells is used on telegraph lines, where a high electromotive force is required in order to overcome a considerable resistance in the circuit, or in similar cases where the resistance in the external circuit is great, on account of a number of electro-receptive devices being connected to the line in series.

The series connection was formerly called *connection for intensity*. The term is now abandoned.

Circuit, Series-Multiple — — A compound circuit, in which a number of separate sources, or separate electro-receptive devices, or both, are connected in a number of separate groups in multiple-arc, and these separate groups subsequently connected in series.

In the series-multiple circuit the resistance of each multiple group is equal to the resistance of a single branch divided by the number of branches.

If, for example, r , is the resistance of each separate branch of say seven parallel circuits in each of the separate groups of multiple circuits, then the resistance, R , of each separate multiple group is—

$$R = \frac{r}{7}$$

The total resistance of the series-multiple circuit is equal to the sum of the resistances of the separate multiple groups. The total resistance of the three groups is—

$$R' = \frac{r}{7} + \frac{r}{7} + \frac{r}{7} = \frac{3r}{7}$$

An example of the series-multiple circuit is shown in Fig. 134, which is the method adopted

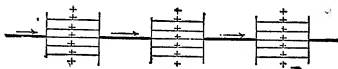

Fig. 134. Series-Multiple Circuit.

in the use of distribution boxes. Here a number of multiple groups or circuits are connected with each other in series, as shown. (See *Box, Distribution, for Arc Light Circuits*.)

Circuit, Short — — A shunt, or by-path.

of comparatively small resistance, around the poles of an electric source, or around any portion of a circuit, by which so much of the current passes through the new path, as virtually to cut out the part of the circuit around which it is placed, and so prevent it from receiving an appreciable current.

Circuit, Shunt — — A branch or additional circuit provided at any part of a circuit, through which the current branches or divides, part flowing through the original circuit, and part through the new branch.

A shunt circuit is in multiple circuit with the circuit it shunts.

In the case of branch circuits each of the circuits acts as a shunt to the others. Any number of additional or shunt circuits may be thus provided. (See *Laws, Kirchoff's*.)

Circuit, Simple — — A circuit containing a single electric source, and a single electro-receptive device, connected by a conductor.

The term *simple circuit* is sometimes applied to a multiple circuit. The term is not, however, a good one, and is not in general use.

Circuit, Single-Wire — — A term sometimes used for a grounded circuit. (See *Circuit, Grounded*.)

The single-wire circuit is sometimes used in the distribution of incandescent lamps in multiple-arc. One pole of the dynamo is put to ground, and the other pole to a single wire or lead. The electro-receptive devices have one of their poles connected to this lead and the other pole to earth. The single-wire circuit is a very objectionable circuit so far as safety is concerned.

It is frequently used, however, in the wiring of ships.

Circuit, Through — — A telephonic or telegraphic circuit that has been completed through to a given station by cutting out interruptions or breaks in the line by the connection together of sections of different wires.

Circuit, Time-Constant of — — The time in which a current due to a constant electromotive force will rise in a conductor to a definite fraction of its maximum value.

The ratio of the inductance of a circuit to its resistance.

The time required from the moment of closing the circuit, for a current to rise to a value equal to $\frac{e-I}{e}$ of the full value, or

.632 of the maximum value.

In the above, e , equals 2.71828, or the base of the Napierian system of logarithms.

The time-constant is proportional to the conductivity of the circuit and its formal resistance.

Approximately the time constant of a circuit is the time from closing the circuit, in which the current rises to two-thirds of its maximum value, this maximum value being determined by the formula, $C = \frac{E}{R}$.

The time constant of a circuit may be reduced—

(1.) By decreasing the self-induction of the circuit.

(2.) By increasing the resistance.

In the case of a magnetic conductor the time-constant is proportional to a quantity (the permeability) which is determined by the capacity of the conductor to utilize part of the energy in producing magnetization of its substance.—(*Fleming*.)

Circuit, Voltaic — —The path through which the current flows out from a voltaic cell or battery, through the translating devices and back again to the cell or battery.

Circuits, Forked — —A term employed in telegraphy to indicate circuits that radiate from any single point.

Forked circuits are employed in simultaneously transmitting messages to several stations.

Circuits, Varieties of — —Conducting paths provided for the passage of an electric current.

Electric circuits may be divided, according to their complexity, into—

(1.) Simple.

(2.) Compound.

According to the peculiarities of their connections, into—

(1.) Shunt or derived.

(2.) Series.

(3.) Multiple, multiple-arc or parallel.

(4.) Multiple-series.

(5.) Series-multiple.

Either the circuits, the sources, or the electro-

receptive devices may be connected in series, in multiple, in multiple-series or in series-multiple.

According to their resistance, circuits are divided into—

(1.) High-resistance.

(2.) Low-resistance.

According to their relation to the electric source, into—

(1.) Internal circuits.

(2.) External circuits.

According to their position, or the work done, circuits are divided into very numerous classes; thus, in telegraphy, we have the following, viz.:

(1.) The line-circuit.

(2.) The earth or ground circuit.

(3.) The local-battery circuit.

(4.) The main-battery circuit, etc.

Circular Bell.—(See *Bell, Circular*.)

Circular Units.—(See *Units, Circular*.)

Circular Units (Cross-Sections), Table of — —(See *Units, Circular (Cross-Sections), Table of*.)

Clamp, Carbon — —A carbon clutch. (See *Clutch, Carbon, of Arc Lamp*.)

Clamp for Arc Lamps.—A clamp for gripping the lamp-rod, *i. e.*, the rod that supports the carbon electrodes of arc lamps. (See *Lamp, Electric, Arc*.)

Clamp, Rod — —A carbon clutch. (See *Clamp for Arc Lamps*.)

Clark's Compound.—(See *Compound, Clark's*.)

Clark's Standard Voltaic Cell.—(See *Cell, Voltaic, Standard, Clark's*.)

Clark's Standard Voltaic Cell, Rayleigh's Form of — —(See *Cell, Voltaic, Standard, Rayleigh's Form of Clark's*.)

Clay Electrode.—(See *Electrode, Clay*.)

Cleansing, Fire — —The removal of grease from metallic articles, that are to be electro-plated, by subjecting them to the action of heat.

This cleansing is for the purpose of obtaining a uniform, adherent coating.

Clearance-Space.—(See *Space, Clearance*.)

Clearing-Out Drops.—(See *Drops, Clearing-Out.*)

Cleat, Crossing — —A cleat so arranged as to permit the crossing of one pair of wires under or over another pair without contact with each other.

Cleat-Wiring.—(See *Wiring, Cleat.*)

Cleats, Electric — —Suitably shaped pieces of wood, porcelain, hard rubber or other non-conducting material used for fastening and supporting electric conductors to ceilings, walls, etc.

A simple form of wooden cleat is shown in Fig. 135.



Fig. 135. Wooden Cleat.

Clepsydra, Electric — —An instrument for measuring time by the escape of water or other liquid under electrical control.

Climbers, Pole — —
—Devices employed by linemen for climbing wooden telegraph poles.

A climber with straps for attachment to the leg and foot is shown in Fig. 136.

Clip, Cable — —A term sometimes used for cable hanger. (See *Hanger, Cable.*)

Clock, Electric — —A clock, the works of which are moved, controlled, regulated or wound, either entirely or partially, by the electric current.

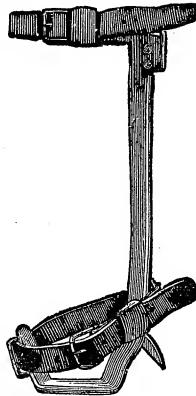

Fig. 136. Climber and Straps.

Electric clocks may be divided into three classes, viz.:

- (1.) Those in which the works are moved entirely or partially by the electric current.
- (2.) Those which are controlled or regulated by the electric current.

(3.) Those which are merely wound by the current.

A clock moving independently of electric power is prevented from gaining or losing time, by means of a slight retardation or acceleration electrically imparted. The entire motion of the balance wheel is sometimes imparted by electricity.

An example of one of many forms of controlling electric clocks is shown in Fig. 137, where the split battery (See *Battery, Split*), P N, is connected, as shown, to the spring contacts S and S'. In this way currents are sent into the circuit in alternately opposite directions.

The pendulum bob, Fig. 138, of the controlled clock is formed of a hollow coil of insulated wire, which encircles one or both of two permanent magnets, A and A', placed with their opposite poles facing each other.

When the pendulum of the controlling clock is in the position shown in Fig. 137, the current passes in the direction E P S n W, etc., and through the coil C, Fig. 138. When the pendulum of the controlling clock is in contact with S', the current flows through W n S' N E, etc., and through the coil C in the opposite direction. In this manner a slight motion forwards or backwards is imparted to the pendulum, which is thus kept in time with the controlling clock.

Mercury contacts are sometimes employed in place of the springs S and S'. Induction currents may also be employed.

Clocks of non-electric action may be electrically controlled, or correctly set at certain intervals, either automatically by a central clock, or by the depression of a key operated by hand from an astronomical observatory.

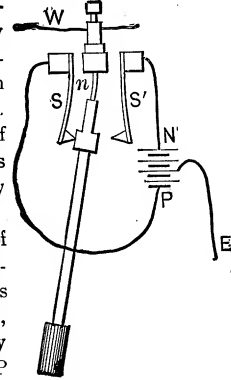

Fig. 137. Controlling Clock.

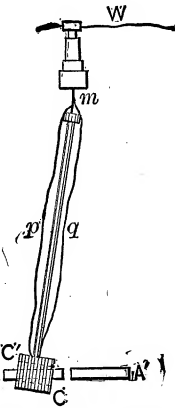

Fig. 138. Controlled Clock.

In a system of *time-telegraphy*, the controlling clock is called the *master clock*, and the controlled clocks, the *secondary clocks*.

Secondary clocks are generally mere dials, con-

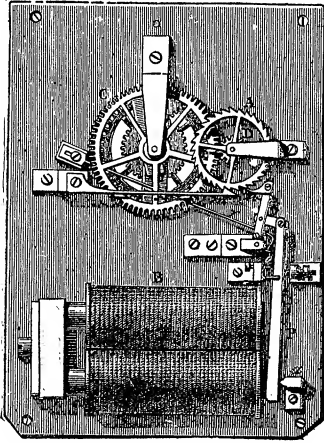

Fig. 139. Mechanism of Secondary Clock.

taining *step-by-step movements*, for moving the hour, minute and second hands, as shown in Fig. 139.

In Spellier's clock, a series of armatures H, Fig. 140, mounted on the circumference of a

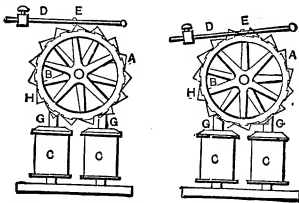

Fig. 140. Spellier's Electric Clock.

wheel, connected with the escapement wheel, pass successively, with a step-by-step movement, over the poles of electro-magnets. On the completion of the circuit, they are attracted towards the magnet, and on the breaking of the circuit they are drawn away by the fall of the weight F, placed on the lever D, pivoted at E. A pulley at E, runs over the surface of a peculiarly shaped cog on the escapement wheel.

Clock, Electric Annunciator — —A clock, the hands or works of which, at certain predetermined times, make electric contacts and thus ring bells, release drops, trace records, etc.

Clock, Electrical-Controlling — —In a system of time telegraphy, the master clock, whose impulses move or regulate the secondary clocks. (See *Clock, Electric*.)

Clock, Electrically-Controlled — —In a system of time telegraphy, a secondary clock, that is either driven or controlled by the master clock. (See *Clock, Electric*.)

Clock, Electrolytic, Tesla's — —A time piece in which the rotation of the wheel work is obtained by the difference in weight of the two halves of a delicately pivoted and well-balanced wheel placed in an electrolytic bath.

In the electrolytic clock of Nikola Tesla, a delicately formed and balanced disc of copper is supported on a horizontal axis at right angles to the shortest distance between the two electrodes, and placed in a bath of copper sulphate. Its two halves become respectively electro-positive and electro-negative when a current is passed through the bath, and consequently metal is deposited on one half and dissolved from the other half. The rotation of the disc under the influence of gravity is caused to mark time.

An electrolytic clock could therefore be made to answer roughly as an electric meter.

Clock, Master — —The central or controlling clock in a system of electric time-distribution, from which the time is transmitted to the secondary clocks in the circuit. (See *Clock, Electric*.)

Clock, Secondary — —Any clock in a system of time telegraphy that is controlled by the master clock. (See *Clock, Electric*.)

Clock, Self-Winding — —A clock that at regular intervals is automatically wound by the action of a small electro-magnetic motor contained within it.

This motor is usually run by one or more voltaic cells, concealed in the case of the clock.

Closed-Circuit.—(See *Circuit, Closed*.)

Closed-Circuit Battery.—(See *Battery, Closed-Circuit*.)

Closed-Circuit, Single-Current, Signaling — —(See *Signaling, Single-Current, Closed-Circuit*.)

Closed-Circuit Thermostat.—(See *Thermostat, Closed-Circuit.*)

Closed-Circuit Voltaic Cell.—(See *Cell, Voltaic, Closed-Circuit.*)

Closed-Circuit Voltmeter.—(See *Voltmeter, Closed-Circuit.*)

Closed-Circuited.—Placed in a closed or completed circuit.

A voltaic battery, or other source, is closed-circuited when its poles or terminals are electrically connected with each other.

Closed-Circuited Conductor.—(See *Conductor, Closed-Circuited.*)

Closed-Circular Current.—(See *Current, Closed-Circular.*)

Closed-Coil Disc Dynamo-Electric Machine.—(See *Machine, Dynamo-Electric, Closed-Coil Disc.*)

Closed-Coil Drum Dynamo-Electric Machine.—(See *Machine, Dynamo-Electric, Closed-Coil Drum.*)

Closed-Coil Dynamo-Electric Machine.—(See *Machine, Dynamo-Electric, Closed-Coil.*)

Closed-Coil Ring Dynamo-Electric Machine.—(See *Machine, Dynamo-Electric, Closed-Coil Ring.*)

Closed-Iron-Circuit Transformer.—(See *Transformer, Closed-Iron-Circuit.*)

Closed-Loop Parallel-Circuit.—(See *Circuit, Closed-Loop Parallel.*)

Closed-Magnetic Circuit.—(See *Circuit, Closed-Magnetic.*)

Closed-Magnetic Core.—(See *Core, Closed-Magnetic.*)

Closure.—The completion of an electric circuit.

Cloth Discs, Carbonized, for High Resistances — — Discs of cloth carbonized by heating to an exceedingly high temperature in a vacuum, or out of contact with air.

After carbonization the discs retain their flexibility and elasticity and serve admirably for high resistances. When piled together and placed in glass tubes, they form excellent variable resistances when subjected to varying pressure.

Club-Footed Magnet.—(See *Magnet, Club-Footed.*)

Clutch, Carbon, of Arc Lamp — — A clutch or clamp attached to the rod or other support of the carbon of an arc lamp, provided for gripping or holding the carbon. (See *Lamp, Electric Arc.*)

Clutch Rod.—(See *Rod, Clutch.*)

Coating, Metallic — — A covering or coating of metal, usually deposited from solutions of metallic salts by the action of an electric current. (See *Plating, Electro.*)

Coating of Condenser.—A sheet of tin foil on one side of a Leyden jar or condenser, directly opposite a similar sheet on the other side for the purpose of receiving and collecting the opposite charges. (See *Jar, Leyden, Condenser.*)

Coatings of Leyden Jar.—The sheets of tin foil or other conductor on the opposite sides of a Leyden jar or condenser. (See *Jar, Leyden, Condenser.*)

Code, Cipher — — A code in which a number of words or phrases are represented by single words, or by arbitrary words or syllables.

The message thus received requires the possession of the key to render it intelligible.

Code, Telegraphic — — The pre-arranged signals of any system of telegraphy. (See *Alphabet, Telegraphic, Alphabet, Telegraphic, Morse's, Alphabet, Telegraphic, International Code.*)

Co-efficient, Algebraic — — A number prefixed to any quantity to indicate how many times that quantity is to be taken.

The number 3, in the expression 3a, is a co-efficient and indicates that the a, is to be taken three times, as $a + a + a = 3a$.

Co-efficient, Economic, of a Dynamo-Electric Machine — — The ratio between the electrical energy, or the electrical horse-power of the current produced by a dynamo, and the mechanical horse-power expended in driving the dynamo.

The economic co-efficient is usually called the efficiency.

The *efficiency* may be the *commercial efficiency*, which is the useful or available energy in the external circuit divided by the total mechanical energy; or it may be the *electrical efficiency*, which is the available electrical energy divided by the total electrical energy.

The *efficiency of conversion* is the total electrical energy developed, divided by the total mechanical energy applied.

If M , equals the mechanical energy,

W , the useful or available electrical energy, and

w , the electrical energy absorbed by the machine, and

m , the *stray power*, or the power lost in friction, eddy currents, air friction, etc.

Then, since

$$M = W + w + m,$$

The Commercial Efficiency

$$= \frac{W}{M} = \frac{W}{W + w + m}.$$

The Electrical Efficiency

$$= \frac{W}{W + w}.$$

The Efficiency of Conversion

$$= \frac{W + w}{M} = \frac{W + w}{W + w + m}.$$

Co-efficient of Electro-Magnetic Inertia.

—(See *Inertia, Electro-Magnetic, Co-efficient of*.)

Co-efficient of Expansion.—(See *Expansion, Co-efficient of*.)

Co-efficient of Expansion, Linear — —
(See *Expansion, Linear, Co-efficient of*.)

Co-efficient of Magnetic Induction.—(See *Induction, Magnetic, Co-efficient of*.)

Co-efficient of Magnetization.—(See *Magnetization, Co-efficient of*.)

Co-efficient of Mutual Inductance.—(See *Inductance, Mutual, Co-efficient of*.)

Co-efficient of Mutual Induction.—(See *Induction, Mutual, Co-efficient of*.)

Co-efficient of Self Induction.—(See *Induction, Self, Co-efficient of*.)

Coercitive Force.—(See *Force, Coercitive*.)

Coercive Force.—(See *Force, Coercive*.)

Coil, Choking — —A coil of wire so

wound on a core of iron as to possess high self-induction.

Choking-coils are used to obstruct or cut off an alternating current with a loss of power less than with the use of a mere ohmic resistance.

Fig. 141 shows a choking-coil. It consists of a circular solenoid of insulated wire, wound on a core of soft iron wire. A thorough division of the core is obtained by forming it of coils of insulated iron wire. In this way, no eddy currents are produced in the coil. When a simple periodic electromotive force is applied to the terminals of such a coil, if

the magnetic permeability of the coil is constant, a simple periodic current is produced, which lags behind the phase of the impressed electromotive force by a constant angle. If

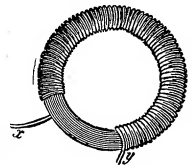

Fig. 141. Choking-Coil.

the impressed electromotive force is sufficiently great to more than saturate the core, the choking coil ceases to choke the current. The higher the periodicity the greater is the choking effect of a given coil, or the smaller the coil may be made to produce a given effect.

Since an open-magnetic circuit requires a greater current to saturate it than a closed-magnetic circuit, the complete throttling or choking power of such a coil is increased by forming its core of a closed-magnetic circuit, *i. e.*, of a circuit in which there is no air space or gap. (See *Circuit, Divided-Magnetic, Circuit, Closed-Magnetic*.)

Coil, Electric — —A convolution of insulated wire through which an electric current may be passed. (See *Magnet, Electro*.)

The term coil is usually applied to a number of turns or to a spool of wire.

Coil, Impedance — —A term sometimes applied to a choking-coil. (See *Coil, Choking*.)

Such a coil has a high self-induction. Its impedance is therefore high. (See *Induction, Self, Impedance*.)

Coil, Induction — —An apparatus consisting of two parallel coils of insulated wire employed for the production of currents by mutual induction. (See *Induction, Mutual, Induction, Electro-Dynamic*.)

A rapidly interrupted battery current, sent through a coil of wire called the *primary coil*, induces alternating currents in a coil of wire called the *secondary coil*.

As heretofore made, the primary coil consists of a few turns of a thick wire, and the secondary coil of many turns, often thousands, of fine wire. Such coils are generally called *Ruhmkorff coils*, from the name of a celebrated manufacturer of them.

In the form of Ruhmkorff coil, shown in Fig. 142, the primary wire, wound on a core formed

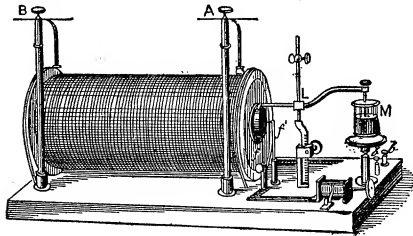

Fig. 142. Ruhmkorff Coil.

of a bundle of soft iron wires, has its ends brought out as shown at *f, f'*. The fine wire, forming the secondary coil, is wrapped around an insulated cylinder of vulcanite, or glass, surrounding the primary coil. This wire is very thin, and in some coils is over one hundred miles in length.

If the core of an induction coil were made solid it would heat considerably and therefore cause a loss of energy. The core is therefore laminated, usually by forming it of a bundle of soft iron wire.

Too great a division of the core, however, is inadvisable, since, although the eddy currents therein are thereby avoided, yet, too great a division of the core acts practically so to decrease the magnetic permeability that the greatest efficiency cannot be obtained.

The ends of the secondary coil are connected to the insulated pillars *A* and *B*.

The primary current is rapidly broken by means of a mercury break, shown at *L* and *M*.

The *commutator*, shown to the right and front of the base, is provided for the purpose of cutting off the current through the primary, or for changing its direction. When a battery which produces a comparatively large current of but a few volts electromotive force is connected with the primary, and its current rapidly interrupted, a torrent of sparks will pass between *A* and *B*, having an electromotive force of many thousands of times the number of volts of the primary cur-

rent, but of a correspondingly smaller current strength.

In such cases, excepting losses during conversion, the energy in the primary current, or *C E*, is equal to the energy in the secondary current, or *C' E'*. As much therefore as *E'*, the electromotive force of the secondary current, exceeds *E*, the electromotive force of the primary current, the current strength *C'*, of the secondary, will be less than the current strength *C*, of the primary. This is approximately true only, and only in induction coils possessing a closed magnetic circuit. (See *Transformer*.)

Fig. 143 shows diagrammatically the arrange-

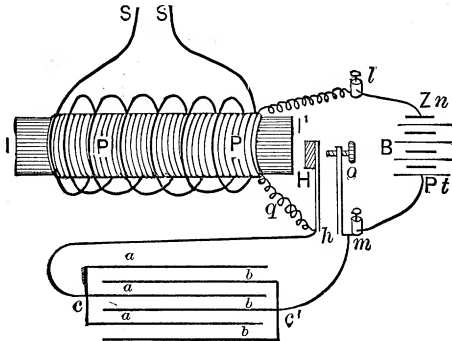

Fig. 143. Circuit Connections of Induction Coil.

ment and connection of the different parts of an induction coil.

The core *II'*, consists of a bundle of soft iron wires, each of which is covered with a thin insulating layer of varnish or oxide. A primary wire *P P*, consisting of a few turns of comparatively thick wire, is wound around the core, and a greater length of thin wire *SS*, is wound upon the primary. This is called the secondary. So as not to confuse the details of the figure it is represented as a few turns.

The terminals of the battery *B*, are connected to the primary wire, through the automatic interrupter, in the manner shown. It will be seen that the attraction of the core *II'*, for the vibrating armature *H*, will break contact at the point *o*, and cause a continued interruption of the battery current.

The condenser *c c'*, is connected as shown. It acts to diminish the sparking at the contact points on breaking contact, and thus, by making the battery current more sudden, to make its inductive action greater.

The reactions which take place when a simple

periodic electromotive force is impressed on the primary of an induction coil are substantially thus stated by J. A. Fleming :

(1.) The application of a simple periodic impressed electromotive force produces a simple periodic current, moving under an effective electromotive force of self-induction, and brings into existence a counter-electromotive force of self-induction, which causes the primary current to lag behind, by an angle called the angle of lag.

(2.) The field around the primary, and, therefore, the induction through the secondary, is *in consonance* with the primary current, and the impressed electromotive force in the secondary is *in quadrature* with the primary current. (See *Consonance. Quadrature, In.*)

(3.) The secondary-impressed electromotive force gives rise to a secondary current moving under an effective electromotive force and creating a counter electromotive force of self-induction.

(4.) This secondary current reacts in its turn on the primary, and creates what is called the back-electromotive force, or the reacting-inductive-electromotive force of the primary circuit.

(5.) There is then a phase-difference between the primary and secondary currents, and also between the primary-impressed electromotive force and the primary current.

If, as in Fig. 144, two electric circuits are

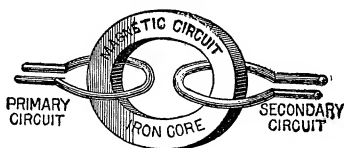

Fig. 144. Electric and Magnetic Link.

linked with a magnetic circuit, and a small periodic electromotive force be impressed on the primary, the following phenomena occur:

(1.) A periodic primary current is set up in the primary circuit, which, though of the same periodic time as the impressed electromotive force, differs from it in phase.

(2.) A wave of counter electromotive force is produced in the primary circuit by the inductive action, which does not coincide either with the impressed electromotive force, nor with the primary current.

(3.) A wave of magnetization is produced in the iron core, which lags behind the primary

current by somewhat less than 90 degrees of phase.

(4.) A wave of impressed electromotive force is produced in the secondary circuit, due to and measured by the rate of change of magnetic induction in the core, and lagging 90 degrees, or more, behind the magnetization wave.

(5.) A wave of secondary current, lagging behind the secondary electromotive force in phase, except where the circuit consists of a few turns of conductor, or is connected with an external circuit of practically no inductance.—(Fleming.)

Coil, Induction, Inverted — —An induction coil in which the primary coil is made of a long, thin wire, and the secondary coil of a short, thick wire.

By the use of an inverted coil, a current of high electromotive force and comparatively small current strength, *i. e.*, but of few *ampères*, is converted or transformed into a current of comparatively small electromotive force and large current strength. For advantages of this conversion see *Electricity, Distribution of, by Alternating Currents*.

Inverted induction coils are called *converters* or *transformers*. (See *Transformer*.)

Coil, Induction, Medical — —An induction coil used for medical purposes.

A form of induction coil used for medical purposes is shown in Fig. 145.

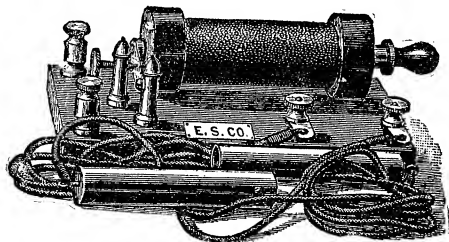

Fig. 145. Medical Induction Coil.

Coil, Induction, Microphone — —An induction coil, in which the variations in the circuit of the primary are obtained by means of microphone contacts. (See *Microphone*.)

The carbon-button telephone transmitter is a microphone in its action, its electric resistance varying with the varying pressure caused by the sound waves. The carbon-button is in the primary circuit of an induction coil, variations in

primary of which, under the influence of the sound waves, produce corresponding variations in the currents induced in the secondary.

Coil, Kicking — —A term sometimes applied to a Choking-Coil. (See *Coil, Choking.*)

The term kicking-coil has arisen from the fact that the impedance due to self-induction opposes the starting or stopping of the current somewhat in the manner of an opposing kick.

Coil, Magnet — —A coil of insulated wire surrounding the core of an electro-magnet, and through which the magnetizing current is passed. (See *Magnet, Electro.*)

Coil, Primary — —That coil or conductor of an induction coil or transformer, through which the rapidly interrupted or alternate inducing currents are sent.

In the Ruhmkorff induction coil the primary coil consists of a comparatively short length of thick wire, the secondary coil being formed of a comparatively great length of fine wire. In the transformer or converter, the primary coil consists of wire that is longer and thinner than that in the secondary coil. In other words, the transformer or converter consists of an *inverted induction coil*. (See *Coil, Induction. Transformer.*)

Coil, Reaction — —A magnetizing coil, surrounded by a conducting covering or sheathing, which opposes the passage of rapidly alternating currents less when directly over the magnetizing coil than when a short distance from it.

A term often used for choking-coil. (See *Coil, Choking.*)

Coil, Reaction, Balanced — —A coil employed in a system of distribution by means of transformers for maintaining a constant current in the secondary circuit, despite changes in the load placed therein.

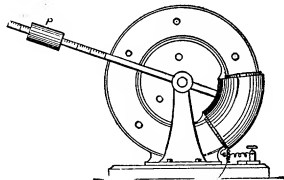

Fig. 146. *Balanced-Reaction Coil.*

A balanced-reaction coil is shown in Fig. 146.

A reaction coil is placed in the circuit of lamps in series in a constant potential system. The sheathing of this coil is maintained in a balanced position by the counter weight P, and the spring S. If now a lamp is extinguished in the circuit, the increase of current, due to decreased resistance, causes the sheath to be deflected, and, thus increasing the self-induction of the coil, reduces the lamp current to its normal value.

Coil, Resistance — —A coil of wire of known electrical resistance employed for measuring resistance.

In order to avoid self-induction and the magnetizing effects of the coils on the needles of the galvanometer used in electric measurements, as well as the disturbing effects of self-induction, the wire of the resistance coil is doubled on itself before being wound, and its ends connected with the brass bars, E, E, Fig. 147. The inser-

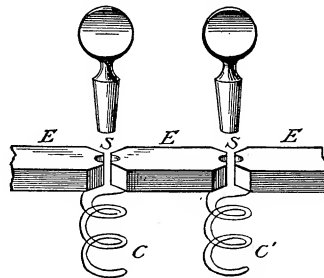

Fig. 147. *Connections of Resistance Coils.*

tion of the plug-key cuts the coil out of the circuit by short-circuiting. (See *Box, Resistance. Bridge, Electric. Coil, Resistance, Standard.*)

The coils are made of German silver, or platinum, the resistance of which is not much affected by heat.

Coil, Resistance, Standard — —A coil the resistance of which is that of the standard ohm or some multiple or sub-multiple thereof.

The standard ohm, as issued by the Electric Standards Committee of England, has the form shown in Fig. 148. The coil of wire is formed of an alloy of platinum and silver, insulated by silk covering and melted paraffine. Its ends are soldered to thick copper rods, r, r', for ready connection with mercury cups. The coil is at B. The space above it, at A, is filled with paraffine. A hole, at t, runs through the coil for the ready

insertion of a thermometer. The lower part of the coil, B, is immersed in water up to the shoulder of A, and the water stirred from time to

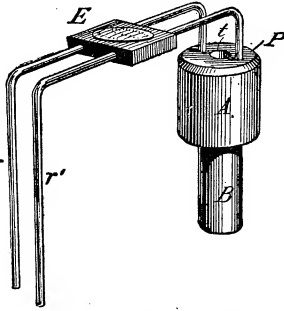

Fig. 148. Standard Ohm.

time. Since the coil is heated by the current, successive observations should be at least ten minutes apart. Only mild currents should be passed through the coils.

Coil, Resistance, Standardized — —

Resistance coils whose resistances have been carefully determined by comparison with a standard ohm or other standard coils.

Coil, Ruhmkorff — —

A term sometimes applied to any induction coil, the secondary of which gives currents of higher electromotive force than the primary. (See *Coil, Induction.*)

Coil, Secondary — —

That coil or conductor of an induction coil or transformer, in which alternating currents are induced by the rapidly interrupted or alternating currents in the primary coil. (See *Coil, Induction. Transformer.*)

Coil, Shunt — —

A coil placed in a derived or shunt circuit. (See *Circuit, Shunt.*)

Coil, Spark — —

A coil of insulated wire connected with the main circuit in a system of electric gas-lighting, the extra spark pro-



Fig. 149. Spark Coil.

duced on breaking the circuit of which is employed for electrically igniting gas jets.

Spark coils are employed where the number of

gas jets to be simultaneously lighted is not too great. When this number exceeds certain limits, the spark from an induction coil is more advantageously used.

A spark coil is shown in Fig. 149.

Coils, Armature, of Dynamo-Electric Machine — —

The coils, strips or bars that are wound or placed on the armature core. To avoid needless resistance the wire, or other conductor, of the armature coils, should be as short and thick as will enable the desired electromotive force to be obtained without excessive speed of rotation.

The armature coils should enclose as many lines of force as possible (*i. e.*, they should have as nearly a circular outline as possible). In drum-armatures, the breadth of the armature is frequently made nearly equal to its length, unless other considerations prevent.

When the armature wire consists of rods or bars, it should be laminated or slit in planes parallel to the lines of force so as to avoid eddy currents. Other things being equal, the

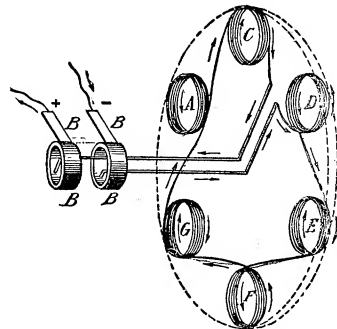

Fig. 150. Series Connection of Armature Coils.

greater the number of coils, the more uniform the current generated. The separate coils should be symmetrically disposed; otherwise irregular induction, and consequent *sparking* at the commutator results.

The coils of pole-armatures should be wound near the poles rather than on the middle of the cores. In order to avoid undue heating, spaces for air ventilation are not inadvisable. Various connections of the armature coils are used.

In some machines all the coils are connected in a closed circuit. In some, the coils are independent of one another, and, either for the entire revolution, or for part of a revolution, are on an open-circuit.

In alternating current dynamos in order to obtain the rapid reversals or alternations of current, which in some machines are as high as 12,000 per minute, a number of poles of alternate polarity are employed. The separate coils that are used on the armature may be coupled either in series or in multiple-arc.

Where a comparatively low electromotive force is sufficient, such as for incandescent lamps in multiple-arc, the separate coils are united in parallel; but for purposes where a considerable electromotive force is necessary, as for example, in systems of alternate current distribution, with converters at considerable distances from the generating dynamo, they are often connected in series, as shown in Fig. 150.

Coils, Binding — —Coils of wire wound on the outside of the armature coils, and at right angles thereto, to prevent the loosening of the armature wires by the action of centrifugal force.

The binding coils are generally made of hard brass wire.

Coils, Compensating — —A term sometimes applied to the series coils placed on a shunt-wound dynamo.

Coils, Conjugate — —Two coils so placed, as regards each other, that an interruption of the current in one produces no induced current in the other.

When two coils are conjugate to each other, the lines of force of one do not pass through the other. Consequently such coils can produce no induction in one another.

Coils, Henry's — —A number of separate induction coils so connected that the currents induced in the secondary wire of the first coil, are caused to induce currents in the secondary wire of the second coil, with whose primary it is connected in series, and so on throughout all the coils.

A series of three of Henry's coils is shown in Fig. 151. An intermittent battery current is sent

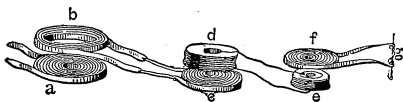

Fig. 151. Henry's Coils.

into a, the secondary, b, of which is connected with the primary, c, of the second coil. The

secondary, d, of the second coil, is connected with the primary, e, of the third coil, and the currents finally induced in f, are employed for any useful purpose, such as the magnetization of a bar of iron at g.

The current in b, is sometimes called a *Secondary Current*, or a Current of the Second Order; that induced by this secondary current in d, is called a *Tertiary Current*, or a *Current of the Third Order*; that in f, a *Current of the Fourth Order*. Henry carried these successive inductions up to currents of the *Seventh Order*.

Henry's coils in reality consist of separate induction coils, connected, as above explained, in series.

In Fig. 152, the tertiary current induced in

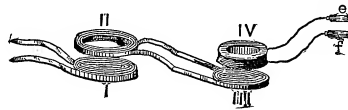

Fig. 152. Tertiary Currents of Coils.

IV, may be employed to give shocks to a person grasping the handles, e and f.

Coils, Proportional — —Pairs of resistance coils, generally of 10, 100 and 1,000 ohms each, forming the proportional arms of the balance or bridge, and employed in the box, or commercial form of Wheatstone's bridge. (See *Bridge, Electric, Commercial Form of*.)

Cold, Production of, by Electricity — —An absorption of energy and consequent reduction of temperature at a thermo-electric junction by the passage of an electric current across such junction in a certain direction.

When an electric current passes across a thermo-electric junction, the junction is either heated or cooled. In the case of an antimony-bismuth couple, if the current passes from the antimony

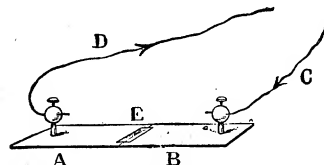

Fig. 153. Freezing of Water by Electricity.

to the bismuth the junction is heated; if it passes from the bismuth to the antimony it is cooled. In the apparatus shown in Fig. 153, the antimony-bismuth couple is arranged as shown for the

freezing of water by means of the electric current. A and B, represent plates of antimony and bismuth respectively. A small cavity, at E, serves to hold a drop of water. When a current has passed in the direction shown by the arrows, a drop of water, previously cooled to the temperature of melting ice, is solidified by the lowering of the temperature at the junction.

Collecting Brushes of Dynamo-Electric Machine.—(See *Brushes, Collecting, of Dynamo-Electric Machine.*)

Collectors, Electric — —Devices employed for collecting or taking off electricity from a moving electric source.

Collectors of Electric Frictional Machines.—The metallic points that collect the charge from the glass plate or cylinder of a frictional electric machine.

Collectors of Dynamo Electric Machines.—The brushes that rest on the commutator cylinder, and carry off the current generated on the rotation of the armature.

Collectors are properly called commutators when they are employed to cause an alternate current to become continuous, or to flow in one and the same direction.

Colloids.—One of the two classes into which substances are separated by dialysis.

By dialysis bodies are separated into crystalloids, or bodies capable of crystallizing, and colloids or jelly-like bodies, incapable of crystallizing. Colloids possess great cohesion and but slight diffusibility. (See *Dialysis.*)

Colombin.—An insulating substance, consisting of a mixture of sulphate of barium and sulphate of calcium, placed between the parallel carbons of the Jablochhoff candle.

Column, Barometric — —A column, usually of mercury, approximately 30 inches in vertical height, sustained in a barometer, or other tube, by the pressure of the atmosphere.

The space above the barometric column contains a vacuum known as the *Torricellian vacuum*. (See *Vacuum, Torricellian.*)

Column, Electric — —A term formerly applied to a voltaic pile. (See *Pile, Voltaic.*)

Colza Oil.—(See *Oil, Colza.*)

Combination Gas Fixtures.—(See *Fixtures, Gas, Combination.*)

Combined Tangent and Sine Galvanometer.—(See *Galvanometer, Combined Tangent and Sine.*)

Comb Lightning Arrester.—(See *Arrester, Lightning, Comb.*)

Comb Protector.—(See *Protector, Comb.*)

Commercial Efficiency.—(See *Efficiency, Commercial.*)

Commercial Efficiency of Dynamo.—(See *Efficiency, Commercial, of Dynamo.*)

Commercial Form of Electric Bridge.—(See *Bridge, Electric, Commercial Form of.*)

Communicator, Electric — —A term formerly employed for a telegraphic key. (See *Key, Telegraphic.*)

Commutating Transformers, Distribution of Electricity by — —(See *Electricity, Distribution of, by Commutating Transformers.*)

Commutation.—The act of commuting, as of currents.

Commutation, Diameter of — —In a dynamo-electric machine a diameter on the commutator cylinder on one side of which the differences of potential, produced by the movement of the coils through the magnetic field, tend to produce a current in a direction opposite to those on the other side.

That diameter on the commutator cylinder of an open-circuited armature that joins the points of contact of the collecting brushes.

Thus in Fig. 154, the directions of the induced electromotive forces are indicated by the arrows. The *diameter of commutation* is therefore the line $n n'$. The term *neutral line* is also sometimes given to this line. It lies at right angles to the line of maximum magnetization $m m$.

In a *closed-circuited* armature, that is, in an armature the coils of which are connected in a closed circuit, the collecting brushes rest on the commutator cylinder at the *neutral line*, or on the *diameter of commutation*.

In an open-circuited armature, however, where the coils are independent of each other, the collecting brushes must be set at $m m$, at right angles to the neutral line $n n$. The term *diameter*

ter of commutation is, therefore, often applied to this second position. According to this use of the

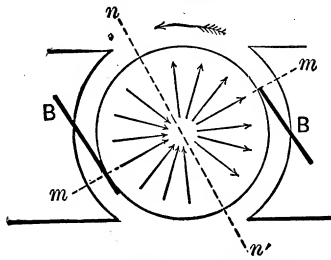

Fig. 154. Diameter of Commutation.

term, the *diameter of commutation* is that diameter on the commutator which joins the points of contact of the collecting brushes.

The neutral line n' , Fig. 154, it will be noticed does not occupy a vertical position, but is displaced somewhat in the direction of rotation, thus necessitating the shifting of the brushes forward in the direction of rotation. This necessary shifting of the brushes is known technically as the *lead of the brushes*. (See *Lead, Angle of*.)

It will thus be seen that the term diameter of commutation is used in two different senses.

In reality, the term refers to the position of certain points on the commutator as distinguished from points on the armature coils. On the commutator, the diameter of commutation is the line drawn through the two commutator bars at which the currents from the two sides are opposed to each other.

It is evident that the commutator may be intentionally twisted with respect to the armature, so as to bring its diameter of commutation into any desired convenient position.

Commutation, Dissymmetry of — —

A commutation in which the neutral line does not coincide with a diameter of the commutator. (See *Commutation, Diameter of*.)

Commutator.—In general, a device for changing the direction of an electric current.

Commutator, Burning at — — Arcing and consequent destructive action on the commutator segments of a dynamo-electric machine.

When the arcing is pronounced, the intense heat soon destroys the commutator.

Commutator Cylinder, Neutral-Line of

— — (See *Line, Neutral, of Commutator Cylinder*.)

Commutator, Dynamo-Electric Machine

— — That part of a dynamo-electric machine which is designed to cause the alternating currents produced in the armature to flow in one and the same direction in the external circuit.

One end of an armature coil is connected with A' , Fig. 155, and the other with A . The brushes are so set that A , and A' , are in contact with B' , and B , respectively, as long as the current flows in the same direction in the armature coil connected therewith, but enter into contact with B , and B' , Fig. 155. *Commutator of Dynamo - Electric Machine.* By the use of a commutator the current will therefore flow through any circuit connected with the brushes in one and the same constant direction.

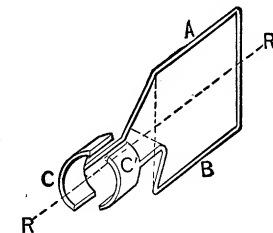
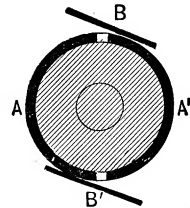

Fig. 156. Two-part Commutator

In action, the commutator is subject to wear from the friction of the brushes, and the *burning* action of destructive sparks. The commutator

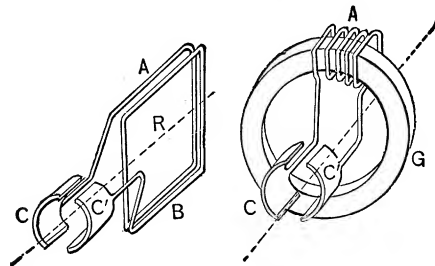

Fig. 157. Two-part Commutator.

Fig. 158. Two-part Commutator.

segments are, therefore, made of comparatively thick pieces of metal, insulated from one another,

and supported on a commutator cylinder usually placed on the shaft of the armature.

The ends of the armature coils are connected to commutator strips or segments.

The number of metallic pieces or segments, A and A', on the commutator cylinder depends on the number, arrangement and connection of the armature coils, and on the disposition of the magnetic field of the machine.

Figs. 156, 157 and 158 show the connections of an armature coil to the plates of a two-part commutator.

A four-part commutator for a ring-armature, and the connections of the coils thereto, are shown in Fig. 159.

The commutator strips may either connect the separate coils in a closed-circuited armature, in which the coils are all connected with one another, or, in an open-circuited armature, in which the separate coils are independent of one another.

Commutator, Ruhmkorff's — — A name given by Ruhmkorff to a device placed on his induction coil for the purpose of changing or reversing the direction of the battery current through the primary.

This reverser is shown in Fig. 160. (See *Coil, Ruhmkorff's*.)

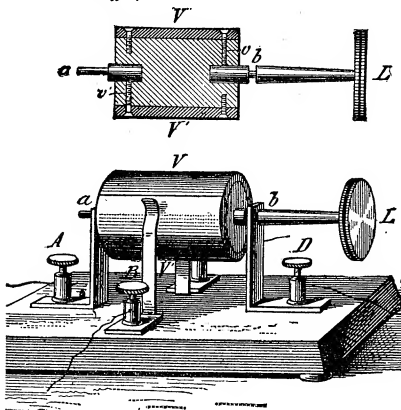

Fig. 160. Ruhmkorff's Commutator.

Two metallic strips, V, V, supported on a cylinder of insulating material, are in contact with the battery terminals A, and D, through two vertical springs that bear on them. On a half rotation of the cylinder by the thumb screw L,

the strips V, V, change places as regards the vertical springs, and thus reverse the direction of the battery current.

Commutated Currents. — (See *Currents, Commuted*.)

Commuter, Current — — Any apparatus by means of which electrical currents, flowing alternately in different directions, may be caused to flow in one and the same direction.

A Commutator.

Commuting. — Causing to flow in one and the same direction.

Commuting Currents. — (See *Currents, Commuting*.)

Compartment Manhole of Conduit. — (See *Manhole, Compartment, of Conduit*.)

Compass, Azimuth — — A compass used by mariners for measuring the horizontal distance of the sun or stars from the magnetic meridian. (See *Azimuth, Magnetic*.)

A mariner's Compass.

A single magnetic needle, or several magnetic needles, are placed parallel to one another on the lower surface of a card, called the *compass card*. This card is divided into the four *cardinal points*, N, S, E and W, and these again subdivided into thirty-two points called *Rhumbs*.

In the azimuth compass these divisions are supplemented by a further division into degrees.

A form of azimuth compass is shown in Fig. 161. In order to maintain the compass box in a

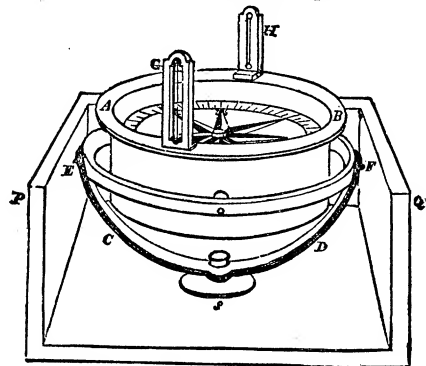

Fig. 161. Azimuth Compass.

horizontal position, despite the rolling of the ship, the box, A B, is suspended in the larger box, P Q, on two concentric metallic circles, C D, and

EF, pivoted on two horizontal axes at right angles to each other. This kind of support is technically termed *Gimbals*. Sights G, H, are provided for measuring the magnetic azimuth of any object.

Compass, Boxing the — — Naming, consecutively, all the different points or rhumbs of the compass from any one of them. (See *Compass, Points of*.)

Compass-Card.—(See *Card, Compass*.)

Compass, Inclination — — A magnetic needle moving freely in a single vertical plane, and employed for determining the angle of dip at any place.

An *Inclinometer*. (See *Inclinometer*.)

A dipping circle. (See *Circle, Dipping*.)

The needle M, Fig. 162, is supported on knife

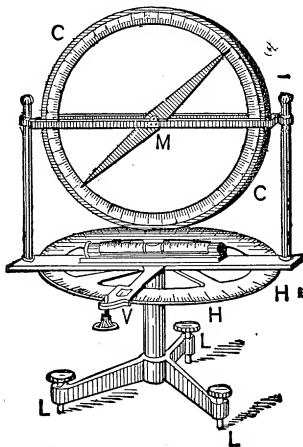

Fig. 162 *Inclination Compass.*

edges so as to be free to move only in the vertical plane of the graduated vertical circle C C. This circle is movable over the horizontal graduated circle H H. In order to determine the true angle of dip, the vertical plane in which the needle is free to move must be placed exactly in the plane of the magnetic meridian.

To ascertain this plane the vertical circle is moved until the needle points vertically downwards. It is then in a plane 90 degrees from the magnetic meridian. The vertical circle is then moved over the horizontal circle 90 degrees, in which position it is in the plane of the magnetic meridian, when the true angle of the dip is read off.

For an explanation of the reason of this see

Component, Horizontal and Vertical, of the Earth's Magnetism.

Compass, Mariner's — — A name often applied to an azimuth compass. (See *Compass, Azimuth*.)

Compass, Points of — — The thirty-two points into which a compass card is divided.

Sixteen of these points are shown in Fig. 163.

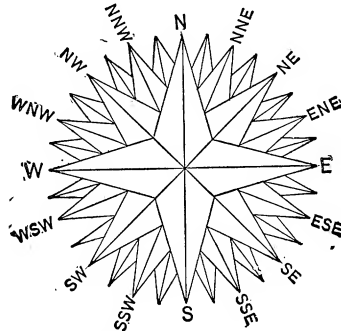

Fig. 163. *Points of Compass.*

The position of the remaining points will be readily seen by an inspection of the figures.

These points are as follows:

- | | |
|-----------------|-----------------|
| 1. North. | 17. South. |
| 2. N. by E. | 18. S. by W. |
| 3. N. N. E. | 19. S. S. W. |
| 4. N. E. by N. | 20. S. W. by S. |
| 5. N. E. | 21. S. W. |
| 6. N. E. by E. | 22. S. W. by W. |
| 7. E. N. E. | 23. W. S. W. |
| 8. E. by N. | 24. W. by S. |
| 9. East. | 25. West. |
| 10. E. by S. | 26. W. by N. |
| 11. E. S. E. | 27. W. N. W. |
| 12. S. E. by E. | 28. N. W. by W. |
| 13. S. E. | 29. N. W. |
| 14. S. E. by S. | 30. N. W. by N. |
| 15. S. S. E. | 31. N. N. W. |
| 16. S. by E. | 32. N. by W. |

Boxing the Compass consists in naming all these points consecutively from any one of them.

The direction in which the ship is sailing is determined by means of a point fixed on the inside of the compass box, directly in the line of the vessel's bow.

Compass, Rhumbs of — — The points of a mariner's compass. (See *Compass, Points of*.)

Compensated Alternator.—(See *Alternator, Compensated.*)

Compensated Excitation of Alternator.—(See *Alternator, Compensated Excitation of.*)

Compensating Coils.—(See *Coils, Compensating.*)

Compensating Magnet.—(See *Magnet, Compensating.*)

Complement of Angle.—(See *Angle, Complement of.*)

Completed-Circuit.—(See *Circuit, Completed.*)

Component.—One of the two or more separate forces into which any single force may be resolved; or, conversely, the separate forces which together produce any single resulting force.

When two or more forces act simultaneously to produce motion in a body, the body will move

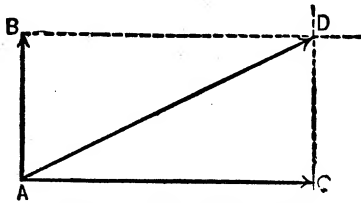

Fig. 164. Composition of Forces.

with a given force in a single direction called the *resultant*. The separate forces, or directions of motion, are called the *components*.

Two forces acting simultaneously on a body at A, Fig. 164, tending to move it in the direction

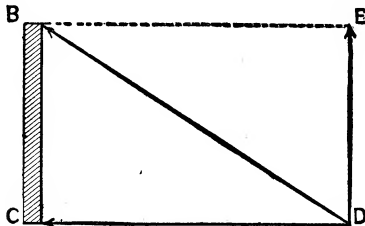

Fig. 165. Resolution of Forces.

of the arrows, along A B, and A C, with intensities proportioned to the lengths of the lines A B, and A C, respectively, will move it in the direction A D, obtained by drawing B D, and D C,

parallel to A C, and A B, respectively, and then drawing A D, through the point of intersection, D. This is called the *Composition of Forces*. A D, is the resultant force, and A B and A C, are its components.

Conversely, a single force, acting in the direction of D B, Fig. 165, against a surface, B C, may be regarded as the resultant of the two separate forces, D E, and D C, one parallel to C B, and one perpendicular to it. D E, being parallel to C B, produces no pressure, and the absolute effect of the force will, therefore, be represented by C D.

This separation of a single force into two or more separate forces is called the *resolution of forces*, the force, D B, being resolved into the components, D E and D C.

Component Currents.—(See *Currents, Component.*)

Component, Horizontal, of Earth's Magnetism — — That portion of the earth's directive force which acts in a horizontal direction.

That portion of the earth's magnetic force which acts to produce motion in a compass needle free to move in a horizontal plane only.

Let A B, Fig. 166, represent the *direction and magnitude* of the earth's magnetic field on a magnetic needle. The magnetic force will lie in the plane of the magnetic meridian, which will be assumed to be the plane of the paper C A D. The earth's field, A B, can be resolved into two components, A D, the *horizontal component*, and A C, the *vertical component*.

In the case of a magnetic needle, like the ordinary compass needle, which is free to move in a horizontal plane only, the horizontal component alone directs the needle. A weight is applied to balance the vertical component.

When the needle is free to move in a vertical plane, and this plane corresponds with that of the magnetic meridian, the entire magnetic force, A B, acts to place the needle, supposed to be properly balanced, in the direction of the lines of force of the earth's magnetic field at that point.

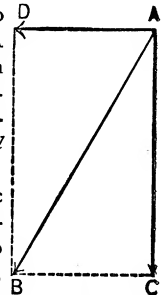

Fig. 166. Components of Earth's Magnetism.

Component, Vertical, of Earth's Magnetism — — That portion of the earth's directive force which acts in a vertical direction.

In the vertical plane at right angles to the plane of the magnetic meridian, the vertical component alone acts, and the needle points vertically downwards, in no matter what part of the earth it may be. In Fig. 166, A C, is the vertical component of the earth's directive force.

Composite Balance.—(See *Balance, Composite*.)

Composite-Field Dynamo.—(See *Dynamo, Composite-Field*.)

Composition of Forces.—(See *Forces, Composition of*.)

Compound Arc.—(See *Arc, Compound*.)

Compound, Binary — — In chemistry, a compound formed by the union of two different elements.

Water is a binary compound, being formed by the union of two atoms of hydrogen with one atom of oxygen. Its composition is expressed in *chemical symbols*, H_2O , which indicates that two atoms of hydrogen are combined, or chemically united, with one atom of oxygen. Water is therefore a binary compound, because it is formed of two different elementary substances.

Compound, Chatterton's — — A compound for cementing together the alternate coatings of gutta-percha employed on a cable conductor, or for filling up the space between the strand conductors.

The composition of Chatterton's compound is as follows:

Stockholm tar.....	1	part	by	weight.
Resin	1	"	"	"
Gutta-percha.....	3	"	"	"

—(Clark & Sabine.)

Compound Circuit.—(See *Circuit, Compound*.)

Compound, Clark's — — A compound for the outer casing of the sheathing of submarine cables.

The composition of Clark's compound is as follows:

Mineral pitch.....	65	parts	by	weight.
Silica.....	30	"	"	"
Tar.....	5	"	"	"

—(Clark & Sabine.)

Compound Horseshoe Magnet.—(See *Magnet, Compound-Horseshoe*.)

Compound Magnet.—(See *Magnet, Compound*.)

Compound Radical.—(See *Radical, Compound*.)

Compound-Winding of Dynamo-Electric Machines.—(See *Winding, Compound, of Dynamo-Electric Machine*.)

Compound-Wound Dynamo-Electric Machine.—(See *Machine, Dynamo-Electric, Compound-Wound*.)

Compound-Wound Motor.—(See *Motor, Compound-Wound*.)

Concentration of Lines of Force.—(See *Force, Lines of, Concentration of*.)

Concentric Carbon Electrodes.—(See *Electrodes, Concentric Carbon*.)

Concentric Cylindrical Carbons.—(See *Carbons, Concentric Cylindrical*.)

Condenser.—A device for increasing the capacity of an insulated conductor by bringing it near another insulated earth-connected conductor, but separated therefrom by any medium that will readily permit induction to take place through its mass.

A variety of electrostatic accumulator.

If the conductor A, Fig. 167, standing alone

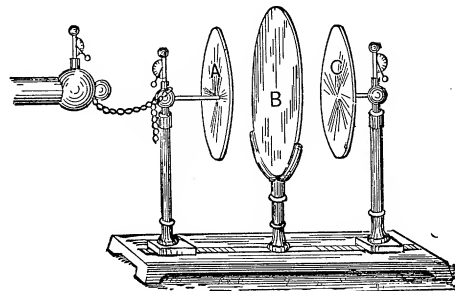

Fig. 167. Aepinus Air Condenser.

and separated from other conductors, be connected with an electric machine, it will receive only a very small charge.

If, however, it be placed near C, but separated from it by a *dielectric*, such as a plate of glass B, and C, be connected with the ground, A, will receive a much greater charge. (See *Dielectric*.)

Suppose, for example, that A, be connected with the positive conductor of a frictional electric machine, it will by *induction* establish a negative charge on the surface C, nearest it, and repel a positive charge to the earth. The presence of these two opposite charges on the opposed surfaces of A and C, permits A, to receive a fresh charge from the machine. (See *Induction, Electrostatic*.)

The charge in a condenser in reality resides on the opposite surfaces of the glass, or other dielectric separating the metallic coatings, as can be shown by removing the coatings after charging.

The condenser resulted from the discovery of the Leyden jar. (See *Jar, Leyden*.)

The capacity of a condenser is measured in *microfarads*. (See *Farad*.)

In practice condensers are made of sheets of tin foil, connected to A and B, respectively, and separated from one another by sheets of oiled silk, paraffined paper, or thin plates of mica, as shown in Fig. 168.

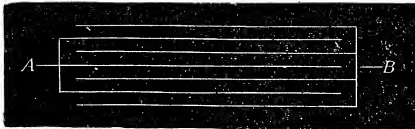

Fig. 168. Condenser.

A Leyden jar or condenser does not store electricity any more than a storage battery does. The same quantity of electricity passes out of the opposite coating of the jar that is passed into the other coating. The jar, therefore, possesses no store of electricity. What it really possesses is a store of electrical energy.

According to Ayrton, if the capacity of a condenser, in farads, be F, and the difference of potential, with which it is charged, be V, volts, the store of electric energy it possesses, or the work it can do when discharged, is,

$$\text{Work} = \frac{F \times V^2}{2.712} \text{ foot-pounds.}$$

Condenser, Adjustable — —A condenser, the plates of which can be readily adjusted so as to obtain the same capacity as that of the conductor to be measured.

In order to obtain a comparatively wide range of adjustability, a condenser is composed of say four separate sections: consisting of one of 2 microfarads, one of 1 microfarad and two of $\frac{1}{2}$ microfarad, thus making in all 4 microfarads.

Condenser, *Epinus* — —A name given to an early form of condenser. (See *Condenser*.)

Condenser, Air — —A condenser in which layers of air act as the dielectric.

A form of air condenser is shown in Fig. 169.

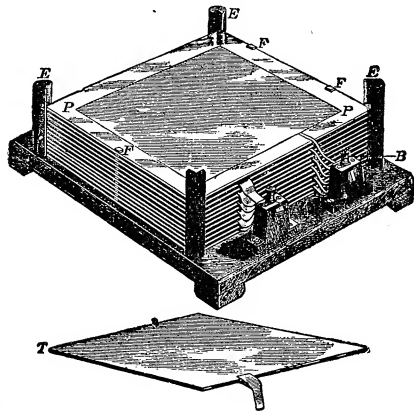

Fig. 169. Air Condenser.

It consists essentially of one set of thin plates of glass partially coated on both sides with sheets of tin foil, so as to leave uncoated a space of about one inch around the edge of the glass. The glass plates do not act as dielectrics, but merely as supports for the tin foil, hence the foil on both sides of the plates is connected electrically.

Another set of plates alternating with the above have the tin foil placed over the whole surface of the glass.

These plates are placed, alternately, over one another on a stand between guide rods of vulcanite E, E, E, E, in the manner shown, and are separated from one another by fragments of glass of the same thickness. The plates with the foil over their entire surface are all connected together and to the terminal B, to form the outer coating, and the plates with the foil over nearly all their surfaces are all connected together and to the terminal A, to form the inner coating of the condenser.

There is thus formed a condenser in which practically two extended conducting surfaces are

separated from each other by a thin layer of air, which acts as the dielectric.

Condenser, Alternating-Current — —

A condenser suitable for use in connection with a system for the distribution of electric energy by means of alternating currents.

Alternating-current condensers must have a very thin dielectric in order to avoid too great bulk. This, of course, introduces a difficulty as regards liability of failure of insulation, which must be carefully avoided.

Condenser, Armature of — — (See *Armature of a Condenser*.)

Condenser, Capacity of — — — The quantity of electricity in coulombs a condenser is capable of holding before its potential in volts is raised a given amount.

The ratio between the quantity of electricity in coulombs on one coating and the potential difference in volts between the two coatings.—(*Ayrton*.)

The capacity is directly proportional to the charge Q , and inversely proportional to the potential V , or,

$$K = \frac{Q}{V},$$

or, since $Q = K V$, the quantity of electricity required to charge a condenser to a given potential is equal to the capacity of the condenser multiplied by the potential through which it is carried.

The capacity of a condenser increases in direct proportion to the increase in the area of its coatings.

When the coatings are plane and parallel to each other, the capacity of the condenser is in the inverse ratio to the distance between the coatings.

Condenser, Coating of — — (See *Coating of Condenser*.)

Condenser, Plate — — — A condenser, the metallic coatings of which are placed on suitably supported plates.

Condenser, Poles of — — (See *Poles of Condenser*.)

Condenser, Time-Constant of — — — The time in which the charge of a condenser falls to the 1-2.71828 part of its original value.

Condensers, Distribution of Electricity by Means of — — (See *Electricity, Distribution of*.)

by Alternating Currents, by means of Condensers. Electricity, Distribution of, by Continuous Currents, by means of Condensers.)

Conduct.—To pass electricity through conducting substances.

To determine the general direction in which electricity shall pass through the ether or dielectric surrounding the so-called conducting substance. (See *Conduction, Electric*.)

Conductance.—A word sometimes used in place of conducting power.

Conductivity.

Conductance, Magnetic — — — A word sometimes used instead of magnetic permeability. (See *Permeability Magnetic*.)

The magnetic conductance is equal to the total induction through the circuit divided by the magnetizing force.

Conducting Cord.—(See *Cord, Conducting*.)

Conducting, Electrical — — — Possessing the power of passing electricity through any conducting substance.

Possessing the power of determining the direction in which electricity shall pass through the ether surrounding a substance. (See *Conductor*.)

Conducting Power.—(See *Power, Conducting*.)

Conducting Power for Electricity.—(See *Power, Conducting, for Electricity*.)

Conducting Power for Lines of Magnetic Force.—(See *Force, Magnetic, Lines of, Conducting Power of*.)

Conducting Power, Tables of — — — (See *Power, Conducting, Tables of*.)

Conduction Current.—(See *Current, Conduction*.)

Conduction, Disruptive — — — A species of conduction in which the resistance of the conductor is suddenly overcome.

Disruptive conduction is seen in the disruptive discharge of a condenser, or Leyden jar.

Conduction, Electric — — — The so-

called flow or passage of electricity through a metallic or other similarly acting substance.

The ability of a substance to determine the direction in which electric energy shall be transmitted through the ether surrounding it.

The ability of a substance to determine the direction in which a current of electricity passes from one point to another.

When a conducting wire has its ends connected with an electric source, a current of electricity is, in common language, said to flow through the wire, and this was formerly believed to be a correct statement. According to modern views, however, the electric energy is believed to pass through the ether or other dielectric surrounding the conductor, the so-called conductor forming merely a sink, where the electrical energy dissipates itself. The conductor simply acts to direct the current.

Since, however, the energy practically passes by means of, and in the general direction of the conductor, there is no objection in speaking of the electricity as flowing through the conductor.

Conduction, Electric, Disruptive — —

A conduction of electric energy which accompanies a disruptive discharge. (See *Discharge, Disruptive*.)

Conduction, Electric, Metallic — — A conducting of electric energy of the same character as that which occurs in metallic substances.

Conduction, Electrolytic — — A term sometimes employed to indicate the passage of electricity through an electrolyte.

There is no passage of electricity through an electrolyte in the same sense as through an ordinary conductor.

When, through electrolysis, an electromotive force is brought to bear on a molecule of say HCl, it is assumed by some that the liberated hydrogen atoms travel on the whole in one direction, and the liberated chlorine atoms in the opposite direction. The atoms thus moving through the liquid may by their electric charges be assumed to convey electricity, and this fact has given rise to the term electrolytic conduction.

In electrolytic conduction the charges are necessarily equal, but the speeds of their motion are unequal. In a given liquid, each atom has

its own rate of motion, no matter with what it has been combined. Hydrogen travels faster than any other kind of atom. The conductivity of a liquid depends on the sum of the speeds with which the two opposed atoms travel.

This assumed double stream of oppositely moving atoms is denied by most physicists. (See *Hypothesis, Grotthus*.)

Conductive-Discharge.—(See *Discharge, Conductive*.)

Conductivity, Electric — — The reciprocal of electric resistance.

Since the conductivity is greater the less the resistance, the conductivity will be equal to the reciprocal of the resistance, and may be so defined. The conductivity is therefore equal to $\frac{1}{R}$.

Conductivity, Equivalent — — A conductivity equal to the sum of several conductivities.

Conductivity per Unit of Mass.—The reciprocal of the resistance of a substance per unit of mass.

Conductivity per Unit of Volume.—The reciprocal of the resistance of a substance per cubic centimetre or per cubic inch.

The resistance is measured from one face of the cube to the opposite face.

Conductivity Resistance.—(See *Resistance, Conductivity*.)

Conductivity, Specific — — The particular conductivity of a substance for electricity.

The specific or particular resistance of a given length and unit of cross-section of a substance as compared with the same length and area of cross-section of some standard substance.

Conductivity, Specific Magnetic — — The specific or particular permeability of a substance to lines of magnetic force.

The specific magnetic conductivity is measured by the ratio of the magnetization produced to the magnetizing force which produces it.

The specific magnetic conductivity is the analogue of specific inductive capacity, or conductivity for lines of electrostatic force. It is also the analogue for specific conducting power for heat.

Conductor.—A substance which will permit the so-called passage of an electric current.

A substance which possesses the ability of determining the direction in which electricity shall pass through the ether or other dielectric surrounding it.

Some electrolytes, such, for example, as various mixtures of sulphuric acid and water, possess a true power of conducting electricity, and therefore have a specific resistance. Generally, however, the passage of the electrolyzing current is regarded as different from that of a current which merely heats the conductor.

The space or region around a conductor through which an electric current is passing has a magnetic field produced in it.

The term conductor is opposed to *non-conductor*, or a substance which will not permit the passage of an electric current through it after the manner of a conductor.

The terms conductors and non-conductors are only relative. There are no such things as either perfect conductors or perfect non-conductors.

Conductors in general, are distinguished from electrolytes, in that the latter do not allow the electricity to pass save by undergoing a chemical decomposition.

Conductor, Anisotropic — —A conductor which, though homogeneous in structure like crystalline bodies, has different physical properties in different directions, just as crystals have different properties in the direction of their different crystalline axes.

Anisotropic conductors possess different powers of electric conduction in different directions. But in opposite directions along the same axis their conductivity is equal. They differ in this respect from *isotropic conductors*. (See *Conductor, Isotropic*.)

Conductor, Anti-Induction — —A conductor so constructed as to avoid injurious inductive effects from neighboring telegraphic or electric light and power circuits.

Such anti-induction conductors sometimes consist of a conductor for constant currents and a metallic shield surrounding the conductor, and designed to prevent induction from taking place in the wire itself.

The anti-induction conductor generally con-

sists of twin conductors surrounded by ordinary insulation and sometimes enclosed by some form of metallic shield, in order to prevent the action of electrostatic induction.

When a periodic current is to be transmitted through a conductor, the most effective way of annulling its inductive effects on neighboring circuits is to place the lead of the conductor in the axis of another conductor, used as a return. In other words, to employ concentric cylinders, insulated from one another and from the earth. Under these conditions, calling the current in one direction positive, and in the other direction negative, the shielding action will be perfect when the algebraic sum of the currents in the core and sheath are zero.

The same effect is obtained in metallic circuits, by placing the leads parallel to the return, and crossing and recrossing the wires repeatedly. (See *Connection, Telephonic Cross*.)

Elihu Thomson renders ordinary telephone conductors, arranged as single lines with earth returns, free from induction by means of the counter-electromotive force produced in a coil of wire by the disturbing cause.

In applying this system to the case of an electric arc or power line passing alongside a telephone line, a wire coil, whose turns are proportioned in number to the induction to be balanced, is introduced into the electric light line and placed near another coil of finer wire inserted as a loop in the telephone circuit. The second coil is placed parallel to or inclined at an angle to the first coil. In practice, the second coil is inclined until the counter-induction set up in the telephone wire is equal to that produced in the main line, and silence is thus produced, so far as induction is concerned, in the telephone.

Conductor, Armored — —A conductor provided with a covering or sheathing of metal placed over the insulating covering for protection from abrasion or external wear.

Armored conductors are used in situations where the conductor is exposed to abrasion or other external wear.

Conductor, Branch — —A conductor placed in a shunt circuit. (See *Circuit, Shunt*.)

Conductor, Closed-Circuited — —A conductor connected as a closed or completed circuit.

Conductor, Conjugate — —In a system of linear conductors, any pair of conductors that are so placed as regards each other that a variation of the resistance or the electromotive force in the one causes no variation in the current of the other.

Conductor, Earth-Circuited — —A conductor connected to the ground, or to an earth-connected circuit.

Conductor, House-Service — —A term employed in a system of multiple incandescent lamp distribution for that portion of the circuit which is included between the service cut-out and the centre or centres of distribution, or between this cut-out and one or more points on house mains.

Conductor, Isotropic — —A conductor which possesses the same powers of electric conduction in all directions.

An electrically homogeneous conducting medium.

Conductor, Leakage — —A conductor placed on a telegraph circuit for the purpose of preventing the disturbing effects of leakage into a neighboring line by providing a direct path for such leakage to the earth.

The leakage conductor, as devised by Varley consists of a thick wire attached to the telegraph pole. The lower end of the conductor is grounded, and its upper end projects above the top of the pole.

There exists some doubt in the minds of experienced telegraph engineers whether it is well to apply leakage conductors to telegraphic or telephonic lines of over 12 or 15 miles in length, since such conductors greatly increase the electrostatic capacity of the line, and thus cause serious retardation.

Conductor, Lightning — —A term sometimes used for a lightning rod. (See *Rod, Lightning*.)

Conductor, Open-Circuited — —A conductor arranged as an open or broken circuit.

Conductor, Potential of — —The relation existing between the quantity of electricity in a conductor and its capacity.

A given quantity of electricity will raise the

potential of a conductor higher in proportion as the capacity of the conductor becomes less.

Conductor, Potential of, Methods of Varying — —The potential of a conductor may be varied in the following ways:

(1.) By varying its electric charge.

(2.) By varying its size or shape without altering its charge.

(3.) By varying its position as regards neighboring bodies.

This resembles the case of a gas whose tension or pressure may be varied as follows, viz.:

(1.) By varying the quantity of gas.

(2.) By varying the size of the gas holder in which it is kept, and

(3.) By varying the temperature.

Difference of potential, therefore, corresponds—

(1.) With difference of level in liquids.

(2.) With difference of pressure in gases.

(3.) With difference of temperature in heat.

—(*Ayrton*.)

Conductor, Prime — —The positive conductor of a frictional electric or electrostatic machine. (See *Machine, Frictional Electric*.)

Conductor, To Short-Circuit a — —To shunt a conductor with a circuit of comparatively small resistance.

Conductor, Underground — —An electric conductor placed underground by actual burial or by passing it through underground conduits or subways.

Underground conductors, though less unsightly than the ordinary aerial conductors, require to be laid with unusual care to render them equally safe, since, when contacts do occur, all the wires in the same conduit are apt to be simultaneously affected, thus spreading the danger in many different directions. They are, however, less liable to dangers arising from occasional accidental crosses or contacts.

Conductors, Service — —Conductors employed in systems of incandescent lighting connected to the street mains and to the electric apparatus placed in the separate buildings or areas to be lighted.

Conduit, Cement-Lined — —A cable conduit, the separate ducts of which are surrounded by any suitable cement.

Conduit, Handhole of — —(See *Handhole of Conduit*.)

Conduit, Manhole of — —(See *Manhole of Conduit*.)

Conduit, Multiple — —A conduit formed of concrete or other insulating material, and furnished with a number of separate ducts.

Conduit, Open-Box — —A conduit consisting of an open box of wood placed in a trench and closed with a wooden cover after the introduction of the cable.

Cables or wires may be drawn through such conduits in the usual manner.

Conduit, Rodding a — —Introducing a wire or rope into the duct of a closed conduit preparatory to drawing the cable through.

Various methods are in use for rodding a conduit. One much followed consists in using sections of gas pipe, the ends of which are furnished with screw threads.

The sections are about four feet in length. One section is pushed into the duct at one manhole and the successive sections are introduced into the duct and screwed onto the section in the duct and pushed through until a sufficient length is obtained to reach the next manhole, a rope or cable is then pulled through from one manhole to the next.

Conduit, Underground Electric — —An underground passageway or space for the reception of electric wires or cables. (See *Subway, Electric*.)

Congelation.—The act of freezing, or the change of a liquid into a solid on loss of heat, or change of pressure.

Conjugate Coils.—(See *Coils, Conjugate*.)

Connect.—To place or bring into electric contact.

Connecting.—Placing or bringing into electric contact.

Connection for Intensity.—Connection in series. (See *Connection, Series*.)

This term is now nearly obsolete.

Connection for Quantity.—Connection in multiple. (See *Connection, Multiple*.)

This term is now nearly obsolete.

Connection, Mercurial — —A form of readily adjustable connection obtained by providing the poles of one piece of electric apparatus with cups or cavities filled with mercury, into which the terminals of another piece of apparatus are dipped in order to place the two in circuit with each other.

This form of connection is used particularly when a very perfect contact or one free from friction is desired.

Connection, Multiple — —Such a connection of a number of separate electric sources, or electro-receptive devices, or circuits, that all the positive terminals are connected to one main or positive conductor, and all the negative terminals are connected to one main or negative conductor.

In the multiple connection of a number of electro-receptive devices, when the devices are connected as above described to positive and negative leads that are maintained at a constant difference of potential, the current passes through the devices from one lead to the other by branching and flowing through as many separate circuits as there are separate receptive devices, and the opening or closing of one of these circuits does not affect the others. (See *Circuits, Varieties of*.)

Connection, Multiple-Series — —Such a connection of a number of separate electric sources, or separate electro-receptive devices, or circuits, that the sources or devices are connected in a number of separate groups in series, and each of these groups connected to main positive and negative conductors or leads in multiple arc. (See *Circuits, Varieties of*.)

Connection of Battery for Quantity.—(See *Battery, Connection of, for Quantity*.)

Connection of Electric Sources in Cascade.—(See *Cascade, Connection of Electric Sources in*.)

Connection of Voltaic Cells for Intensity.—(See *Intensity, Connection of Voltaic Cells for*.)

Connection, Series — —The connection of a number of separate electric sources, or electro-receptive devices, or cir-

cuits, so that the current passes successively from the first to the last in the circuit. (See *Circuits, Varieties of.*)

Connection, Series-Multiple — — Such a connection of a number of separate electro-receptive devices, that the devices are placed in multiple groups or circuits, and these separate groups connected with one another in series.

Connection, Telephonic Cross — — A device employed in systems of telephonic communication for the purpose of lessening the bad effects of induction, in which equal lengths of adjacent parallel wires are alternately crossed so as to alternately occupy the opposite sides of the circuit.

Connector.—A device for readily connecting or joining the ends of two or more wires. (See *Post, Binding.*)

Connector, Double — — A form of binding screw suitable for readily connecting two wires together.

A form of double connector is shown in Fig. 170.

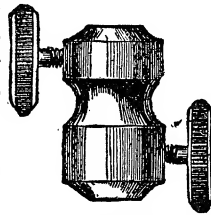

Fig. 170. Double Connector.

Conning Tower. — (See *Tower, Conning.*)

Consequent Points.—(See *Points, Consequent.*)

Consequent Poles.—(See *Poles, Consequent.*)

Conservation of Energy.—(See *Energy, Conservation of.*)

Consonance, "In Consonance."—A term employed to express the fact that one simple periodic quantity, *i. e.*, a wave or vibration, agrees in phase with another.

Constant.—That which remains invariable.

Constant-Current.—(See *Current, Constant.*)

Constant-Current Circuit.—(See *Circuit, Constant Current.*)

Constant-Current, Distribution of Electricity by — — (See *Electricity, Distribution of, by Constant Currents.*)

Constant, Dielectric — — A term sometimes employed in place of specific inductive capacity. (See *Capacity, Specific Inductive.*)

Constant, Galvanometer — — The numerical factor connecting the current passing through a galvanometer with the deflection produced by such current.

Sometimes a distinction is made between the galvanometer constant and the reduction factor, the former being used to indicate the relation between the current and the geometrical constant of the galvanometer, while the latter is used in the sense just defined of galvanometer constant.

Constant Inductance.—(See *Inductance, Constant.*)

Constant Potential.—(See *Potential, Constant.*)

Constant-Potential Circuit.—(See *Circuit, Constant-Potential.*)

Constant, Time, of Electro-Magnet — — The time required for the magnetizing current to rise to the $\frac{e-I}{e}$ of its final value.

Contact-Breaker, Automatic — — A device for causing an electric current to rapidly make and break its own circuit.

The spring *c*, Fig. 171, carries an armature of soft iron, *B*, and is placed in a circuit in such a manner that the circuit is closed when platinum contacts placed on the ends of *D* and *B*, touch each other. In this case the armature, *B*, is attracted to the core *A*, of the electro-magnet, thus breaking the circuit

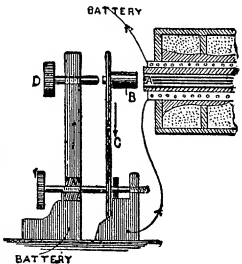

Fig. 171. Automatic Contact Breaker.

and causing the magnet to lose its magnetism. The elasticity of the spring *C*, causes it to fly back and again close the contacts, thus again energizing the electro-magnet and again attracting *B*, and breaking the circuit. The makes and breaks usually follow each other so rapidly as to produce a musical note. (See *Alarm, Electric.*)

Contact, Dotting — — An electric con-

tact obtained by the approach of one contact point towards another.

The term dotting contact is used in contradistinction to a rubbing contact. The rubbing contact is generally to be preferred, since it tends automatically to remove dust and keep the contact surfaces polished and free from oxides.

Contact Dynamo.—(See *Dynamo, Contact*.)

Contact Electricity.—(See *Electricity, Contact*.)

Contact, Fire-Alarm — —A contact so arranged that an alarm is given when any predetermined temperature is reached.

Fire-alarm contacts are generally operated by the expansion of a metal or of a conducting fluid, such as mercury. (See *Thermostat*.)

Contact Force.—(See *Force, Contact*.)

Contact, Full-Metallic — —A contact, which from its small resistance establishes a good or complete connection. (See *Contact, Metallic*.)

Contact, Intermittent — —The occasional contact of a telegraphic or other line with other wires or conductors by swinging, or by alternate contraction or expansion under changes of temperature.

Contact, Metallic — —A contact of a metallic conductor produced by its coming into firm connection with another metallic conductor.

Contact, Partial — —A contact of a telegraphic, or other line, arising from defective insulation, bad earths, or connection with an imperfect conductor.

Contact, Rolling — —A contact connected with one part of an electric circuit, that completes the circuit by being rolled over a conductor connected with and forming another part of the circuit.

Rolling contacts are employed on electric railroads. (See *Railroad, Electric*.)

Contact, Rubbing — —A contact effected by means of a rubbing motion.

Contact Series.—(See *Series, Contact*.)

Contact, Sliding — —A contact connected with one part of a circuit that closes

or completes an electric circuit by being slid over a conductor connected with another part of the circuit.

Sliding contacts are employed in electric railroads, in rheostats, switches, and a variety of other apparatus. (See *Railroad, Electric, Rheostat, Key, Discharge*.)

Contact, Spring — —A spring-supported contact connected with one part of a circuit that completes said circuit by being moved so as to touch another contact connected with the other part of the circuit.

The movement required to bring the two contacts together may be non-automatic, as in the case of a push-button, or automatic, as in the case of a thermostat. (See *Button, Push, Thermostat*.)

Contact Theory of Voltaic Cell.—(See *Cell, Voltaic, Contact Theory of*.)

Contact, Vibrating — —A spring contact, connected with one part of a circuit and so supported as to be able to vibrate towards and from another contact connected with another part of the circuit, thus automatically closing and opening said circuit.

A vibrating contact is used in the automatic contact-breaker in which the movement of an armature towards an electro-magnet is caused to break the circuit of the coils of the electro-magnet, and, on its movement away from the magnet, to close another contact which again completes the circuit of the electro-magnet. (See *Contact Breaker, Automatic*.)

Contact, Wiping — —A contact obtained by a wiping movement of one conductor against another.

The spark for electrically igniting a gas jet is obtained by means of a wiping contact of a spring moved by the motion of the pendant. (See *Burner, Plain-Pendant Electric*.)

Contacts.—A variety of faults occasioned by the accidental contact of a circuit with any conducting body.

The word contacts as employed above is in the sense of accidental contacts as distinguished from predetermined contacts.

Contacts of an accidental character are of the following varieties, viz.:

(1.) *Full, or metallic*, as when the circuit is

accidentally placed in firm connection with another metallic circuit.

(2.) *Partial*, as by imperfect conductors being placed across wires, or bad earths, or defective insulation.

(3.) *Intermittent*, as by occasional contacts of swinging wires, etc.

Contacts, Burglar Alarm — —Contacts fitted to windows, doors, tills, steps, floors, etc., so that a movement of the parts from their natural position gives an alarm by sounding a conveniently located bell.

Contacts, Lamp — —Metallic plates or rings connected with the terminals of an incandescent lamp for ready connection with the line.

Contacts, Mercurial — —Electric contacts that are opened or closed by the expansion or contraction of a mercury column.

In the commonest forms of mercurial contacts, on the expansion of the mercury by heat it reaches a contact point placed in the tube, and thus completes the circuit through its own mass.

Or, on contraction it breaks a contact, and thus disturbing an electric balance, sounds an alarm.

Continental Code Telegraphic Alphabet. —(See *Alphabet, Telegraphic, International Code.*)

Continuity of Current.—(See *Current, Continuous.*)

Continuous Current.—(See *Current, Continuous.*)

Continuous Current, Distribution of Electricity by — —(See *Electricity, Distribution of, by Constant Currents.*)

Continuous Current, Dynamo-Electric Machine — —(See *Machine, Dynamo-Electric, Continuous Current.*)

Continuous-Sounding Electric Bell.—(See *Bell, Continuous-Sounding Electric.*)

Continuous Wires or Conductors.—(See *Wires or Conductors, Continuous.*)

Contraction, Anodic Closure — —The muscular contraction observed on the closing of a voltaic circuit, the anode of which is placed over a nerve, and the kathode at some other part of the body.

This term is generally written A. C. C.

Contraction, Anodic Duration — —The length of time the muscle continues in contraction on the opening or closing of a circuit, the anode of which is placed over the part contracted.

This term is generally written A. D. C.

Contraction, Anodic Opening — —The muscular contraction observed on the opening of a voltaic circuit, the anode of which is placed over a nerve, and the kathode at some other part of the body.

This term is generally written A. O. C.

When the anode is placed over a nerve and a weak current is employed, if the circuit be kept closed for a few minutes, it will be noticed that, on opening the circuit the contraction will be much greater than if it had been opened after being closed for only a few seconds. The effect of the A. O. C. therefore depends not only on the current strength, but also on the time during which the current has passed through the nerve.

Contraction of Lines of Magnetic Force. —(See *Force, Magnetic, Contraction of Lines of.*)

Contractures.—In electro-therapeutics, prolonged muscular spasms, or tetanus, caused by the passage of electric currents.

Contraplex Telegraphy.—(See *Telegraphy, Contraplex.*)

Controlled Clock.—(See *Clock, Electric.*)

Controller.—A magnet, in the Thomson-Houston system of automatic regulation, whose coils are traversed by the main current, and by means of which the regulator magnet is automatically thrown into or out of the main circuit on changes in the strength of the current passing. (See *Regulation, Automatic.*)

Controlling Clock.—(See *Clock, Electric.*)

Controlling Magnet.—(See *Magnet, Controlling.*)

Convection Currents.—(See *Currents, Convection.*)

Convection, Electric — —The air particles, or air streams, which are thrown off from the pointed ends of a charged, insulated conductor.

Convection streams, like currents flowing through conductors, act magnetically, and are themselves acted on by magnets. The same thing is true of the brush discharge, of the voltaic arc, and of convective discharges in vacuum tubes.

Convection, Electrolytic — —A term proposed by Helmholtz to explain the apparent conduction of electricity by an electrolyte, without consequent decomposition.

Helmholtz assumes that the atoms of oxygen or hydrogen, adhering to the electrodes during electrolysis, are mechanically dislodged and diffused through the liquid, thus carrying off the electricity by the charges received while in contact with the electrodes.

Convection of Heat, Electric — —(See *Heat, Electric Convection of.*)

Convection Streams.—(See *Streams, Convection.*)

Convective Discharge.—(See *Discharge, Convective.*)

Conversion, Efficiency of, of Dynamo — —The total electric energy developed by a dynamo, divided by the total mechanical energy required to drive the dynamo. (See *Co-efficient, Economic, of a Dynamo-Electric Machine.*)

The efficiency of conversion

$$= \frac{W + w}{M} = \frac{W + w}{W + w + m},$$

where W, equals the useful or available electrical energy, M, the total mechanical energy, w, the electrical energy absorbed by the machine, and m, the stray power, or the power lost in friction, eddy currents, air friction, etc.

Converted Currents.—(See *Currents, Converted.*)

Converter.—The inverted induction coil employed in systems of distribution by means of alternating currents.

A term sometimes used instead of transformer. (See *Transformer.*)

Converter, Closed-Iron Circuit — — A closed-iron circuit transformer. (See *Transformer, Closed-Iron Circuit.*)

Converter, Constant-Current — — A constant-current transformer. (See *Transformer, Constant-Current.*)

Converter, Efficiency of — —The efficiency of a transformer. (See *Transformer, Efficiency of.*)

Converter Fuse.—(See *Fuse, Converter.*)

Converter, Hedgehog — —A form of transformer. (See *Transformer, Hedgehog.*)

Converter, Multiple — —A multiple transformer. (See *Transformer, Multiple.*)

Converter, Open-Iron-Circuit — —An open-iron-circuit transformer. (See *Transformer, Open-Iron-Circuit.*)

Converter, Series — —A series transformer. (See *Transformer, Series.*)

Converter, Step-down — —A step-down transformer. (See *Transformer, Step-down.*)

Converter, Step-up — —A step-up transformer. (See *Transformer, Step-up.*)

Converter, Welding — —A welding transformer. (See *Transformer, Welding.*)

Converting Currents.—(See *Currents, Converting.*)

Cooling Box of Hydro-Electric Machine. —(See *Box, Cooling, of Hydro-Electric Machine.*)

Co-ordinates, Axes of — —The axes of abscissas and ordinates.

The two straight lines, usually perpendicular to each other, to which distances representing values are referred for the graphic representation of such values. (See *Abscissas, Axes of.*)

Copper Bath.—(See *Bath, Copper.*)

Copper Plating.—(See *Plating, Copper.*)

Copper Ribbon.—A variety of strap copper. (See *Copper, Strap.*)

Copper, Strap — —Copper conductors in the form of straps or flat bars.

Strap copper is used on the armatures of some dynamos. Heavy copper conductors for such purposes are divided into strap copper so as to avoid eddy currents. The straps are placed alongside one another and insulated by a coating of varnish.

Copper Wire, Hard-Drawn — —(See *Wire, Copper, Hard-Drawn.*)

Copper Wire, Soft-Drawn — —(See *Wire, Copper, Soft-Drawn.*)

Copper Voltmeter.—(See *Voltmeter, Copper*.)

Coppered Plumbago.—(See *Plumbago, Coppered*.)

Coppering, Electro — — Electro-plating with copper. (See *Plating, Electro*.)

Cord-Adjuster.—(See *Adjuster, Cord*.)

Cord, Conducting — — A small flexible cable, usually containing several conductors separated from one another by insulating material.

Cord, Electric — — A flexible, insulated electric conductor, generally containing at least two parallel wires.

Electric cords are named from the purposes for which they are employed, *battery cords, dental cords, lamp cords, motor cords, switch cords, etc.*



Fig. 172. Flexible Cord.

A two-conductor flexible cord, in which each cord is composed of a number of bare copper wires placed parallel to and in contact with one another, is shown in Fig. 172. The several separate wires give flexibility to the cord.

Cord, Pendant — — A flexible conductor provided for conveying the current to a hanging electric lamp supported by it.

Cords, Telephone — — Flexible conductors for use in connection with a telephone.

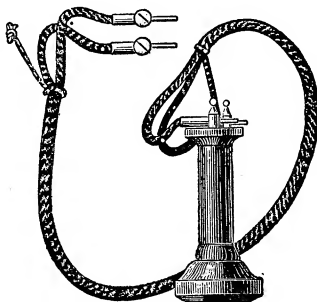

Fig. 173. Telephone Cords.

Telephone cords, attached to an articulating telephone, are shown in Fig. 173.

Core, Armature, Filamentous — — An armature core, the iron of which consists of wire.

Core, Armature, H — — An armature core in the shape of the letter H, generally known as the shuttle armature, and sometimes as the girder armature.

This form is also called an I armature.

The H armature core was the form originally given to the Siemens armature. In this form a single coil of wire was secured on the cross-bar of the H armature core, so as to fill up the entire space inside the letter, and the ends of the wire connected to a two-part commutator.

Core, Armature, Lamination of — — The subdivision of the core of the armature of a dynamo-electric machine into separate insulated plates or strips for the purpose of avoiding eddy or Foucault currents.

This lamination must always be perpendicular to the direction of the eddy currents that would otherwise be produced. (See *Currents, Eddy*.)

Core, Armature, of Dynamo-Electric Machine — — The iron core, on, or around which, the armature coils of a dynamo-electric machine are wound or placed.

The armature core is laminated for the purpose of avoiding the formation of *eddy* or Foucault *currents*.

In *drum*, and in *ring-armatures*, the laminæ should be in the form of thin insulated discs or plates of soft iron; in *pole-armatures* they should be in the form of bundles of insulated wires.

The iron in the cores should be of such an area of cross-section, as not to be readily oversaturated.

Core, Armature, Radially-Laminated — — An armature core, the iron of which consists of thin iron washers.

Core, Armature, Ribbed — — A cylindrical armature core provided with longitudinal projections or ribs that serve as spaced channels or grooves for the reception of the armature coils.

Core, Armature, Tangentially-Laminated — — An armature core, the iron of which consists of a coiled ribbon.

Core, Armature, Ventilation of — — Means for passing air through the armature

cores of dynamo-electric machines in order to prevent undue accumulation of heat.

A properly proportioned dynamo-armature may need no ventilation, since in such the amount of heat generated is small as compared with the extent of the radiating surface.

Since, however, in practice all armatures tend to heat at full load, especially in certain installations in heated situations, ventilation of the armature is desirable.

Core, Closed-Magnetic — —A magnetic core so shaped as to provide a complete iron path or circuit for the lines of magnetic force of its field.

Core, Laminated — —A core of iron which has been divided or laminated, in order to avoid the injurious production of Foucault or eddy currents.

Core, Lamination of — —Structural subdivisions of the cores of magnets, armatures, and pole-pieces of dynamo-electric machines, electric motors, or similar apparatus, in order to prevent heating and subsequent loss of energy from the production of local, eddy or Foucault currents.

These laminations are obtained by forming the cores of sheets, rods, plates, or wires of iron insulated from one another.

The cores of dynamo-electric machine armatures should be subdivided in planes at right angles to the armature coils; or in planes parallel to the direction of the lines of force and to the motion of the armature; or, in general, in planes perpendicular to the currents that would otherwise be generated in them.

Pole-pieces should be divided in planes perpendicular to the direction of the currents in the armature wires.

Magnet cores should be divided in planes at right angles to the magnetizing current.

Core of Cable.—The conducting wires of an electric cable. (See *Cable, Electric*.)

Core, Open-Magnetic — —Any magnetic core so shaped that the lines of magnetic force of its field complete their circuit partly through iron and partly through air.

Core Ratio of Cable.—(See *Cable, Core Ratio of*.)

Core, Ring — —A hollow, cylindrical core of short length.

Core, Ring, Elongated — —A hollow, cylindrical core of comparatively great length.

Core, Solenoid — —A core so arranged as to be drawn into a solenoid on the passage of the current through its coils, and to be withdrawn therefrom, on the stopping of the current by the action of a spring or weight. (See *Solenoid*.)

Core, Stranded, of Cable — —The conducting wire or core of a cable formed of a number of separate conductors or wires instead of a single conductor of the same weight per foot as the combined conductors.

Core Transformer.—(See *Transformer, Core*.)

Cored Carbons.—(See *Carbons, Cored*.)

Cored Electrodes.—(See *Electrodes, Cored*.)

Coronæ, Auroral — —A crown-shaped appearance, sometimes assumed by the auroral light. (See *Aurora Borealis*.)

Corposant.—A name sometimes given by sailors to a St. Elmo's Fire. (See *Fire, St. Elmo's*.)

Correlation of Energy.—(See *Energy, Correlation of*.)

Corresponding Points.—(See *Points, Corresponding*.)

Cosine.—One of the trigonometrical functions. (See *Trigonometry*.)

Cotangent.—One of the trigonometrical functions. (See *Trigonometry*.)

Coulomb.—The unit of electrical quantity. A definite quantity or amount of the thing or effect called electricity.

Such a quantity of electricity as would pass in one second in a circuit whose resistance is one ohm, under an electromotive force of one volt.

The quantity of electricity contained in a condenser of one farad capacity, when subjected to an electromotive force of one volt.

The quantity of electricity that flows per second past a cross-section of a conductor

conveying an ampère.—(Ayrton.) (See *Ampère. Farad. Volt.*)

Coulomb's Torsion Balance.—(See *Balance, Coulomb's Torsion.*)

Coulomb-Volt.—A Joule, or .7373 foot-pound.

The term is generally written *volt-coulomb*. (See *Volt-Coulomb.*)

Counter, Electric — —A device for counting and registering such quantities as the number of fares collected, gallons of water pumped, sheets of paper printed, revolutions of an engine per second, votes polled, etc.

Various electric devices are employed for this purpose. They are generally electro-magnetic in character.

Counter-Electromotive Force. — (See *Force, Electromotive, Counter.*)

Counter Electromotive Force Lightning Arrester.—(See *Arrester, Lightning, Counter-Electromotive Force.*)

Counter-Electromotive Force of Convective Discharge.—(See *Force, Electromotive, Counter, of Convective Discharge.*)

Counter-Electromotive Force of Mutual Induction.—(See *Force, Electromotive, Counter, of Mutual Induction.*)

Counter-Electromotive Force of Self-Induction.—(See *Force, Electromotive, Counter, of Self-Induction.*)

Counter-Electromotive Force of Self-Induction of the Primary.—(See *Force, Electromotive, Counter, of Self-Induction of the Primary.*)

Counter-Electromotive Force of Self-Induction of the Secondary.—(See *Force, Electromotive, Counter, of Self-Induction of the Secondary.*)

Counter-Electromotive Force of the Primary.—(See *Force, Electromotive, Counter, of the Primary.*)

Counter Inductive Effect.—(See *Effect, Counter Inductive.*)

Couple.—In mechanics, two equal parallel forces acting in opposite directions but not in the same line, and tending to cause rotation.

The *moment*, or *effective power of a couple*, is

equal to the intensity of one of the forces multiplied by the perpendicular distance between the directions of the two forces.

Couple, Astatic — —Two magnets of exactly equal strength so placed one over the other in the same vertical plane as to completely neutralize each other.

An astatic couple has no directive tendency. A pair of magnets combined as an astatic couple is called an astatic needle. (See *Needle, Astatic.*)

Couple, Magnetic — —The couple which tends to turn a magnetic needle, placed in the earth's field, into the plane of the magnetic meridian.

If a magnetic needle is in any other position than in the magnetic meridian, there will be two parallel and equal forces acting at A and B, Fig. 174, in the directions shown by the arrows. Their effect will be to rotate the needle until it comes to rest in the magnetic meridian N S.

The total force acting on either pole of a needle free to move in any direction, is equal to the strength of that pole multiplied by the total intensity of the earth's field at that place; or, if free to move in a horizontal direction only, is equal to the intensity of the earth's horizontal component of magnetism at that place, multiplied by the strength of that pole.

The effective power or moment of a magnetic couple is equal to the force exerted on one of the poles multiplied by the perpendicular distance, P Q, between their directions.

Couple, Moment of — —The effective power or force of a couple.

The moment of a couple is equal to the intensity of one of the forces multiplied by the perpendicular distance between the direction of the forces.

Couple, Thermo-Electric — —Two dissimilar metals which, when connected at their ends only, so as to form a completed electric circuit, will produce a difference of potential, and hence an electric current, when one of the ends is heated more than the other.

Thus if a bar of bismuth be soldered to a bar

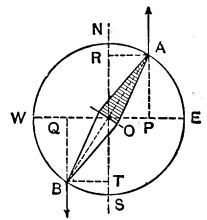

Fig. 174. Magnetic Couple.

of antimony the combination will form a thermo-electric couple, and the circuit so formed will have a current passing through it when one junction is hotter or colder than the other.

There is, according to Lodge, a true contact force, at a thermo-electric junction, as is shown by the reversible heat effects produced when an electric current is passed across such junction; for, in one direction more heat is produced, and in the opposite direction less heat. This, as is well known, differs from the irreversible heat produced by a current through a homogeneous metallic conductor. The reversible heat effects, or as they are called the *Peltier effects*, may overpower and conceal the heating effects. But, in addition to these effects, since a difference of potential, called a *Thomson effect*, exists in a substance unequally heated, currents are so produced, and these are also influential in causing the difference of potential of a thermo-electric couple.

"There are then," says Lodge, "in a simple circuit of two metals with their junctions at different temperatures, altogether four E. M. Fs., one in each metal, from hot to cold, or *vice versa*, and one at each junction, and the current which flows around such a circuit is propelled by the resultant of these four." * * * "These four forces, two Thomson forces in the metals, and two Peltier forces at their junctions, may some of them help and some hinder the current." * * * "Whenever they help, the locality is to that extent cooled; whenever they hinder, it is to that extent warmed."

The action of a thermo-electric couple in producing a difference of potential is therefore a complicated one, and depends on Peltier and Thomson effects, as well as on the thermo-electric effect. (See *Effect, Peltier. Effect, Thomson. Effect, Thermo-Electric.*)

Couple, Voltaic— — Two materials, usually two dissimilar metals, capable of acting as an electric source when dipped in an electrolyte, or capable of producing a difference of electric potential by mere contact.

Liquids and gases are capable of acting as voltaic couples.

All voltaic cells have two metals, or a metal and a metalloid, or two gaseous or liquid substances which are of such a character that, when dipped into the exciting fluid one only is chemically acted on.

Each one of these two substances is called an *element* of the cell, and the two taken collectively form a *voltaic couple*.

The elements of a voltaic couple may consist of two gases or two liquids. (See *Battery, Gas.*)

Coupled Cells.—(See *Cells, Coupled.*)

Coupler, Voltaic — —Any device by means of which voltaic cells may be readily coupled or connected in different forms of circuits. (See *Circuits, Varieties of.*)

Coupling of Voltaic Cells or Other Electric Sources.—A term indicating the manner in which a number of separate electric sources may be connected so as to form a single source. (See *Circuits, Varieties of.*)

Cramp, Telegrapher's — —An affection of the hand of a telegrapher due to immoderate and excessive use of the same muscles, somewhat similar to the disease known as writer's cramp.

Telegrapher's cramp, like writer's cramp, may be defined as a professional neurosis of co-ordination. It appears not only in certain groups of muscles, but is limited to such groups, only when they are performing certain complicated operations. For example, telegrapher's cramp is practically a paralysis of certain muscles of the hand and wrist of the operator. These muscles, when called on to perform the somewhat delicate movements required in sending a telegraphic dispatch, are incapable of performing their proper functions, but when called on to perform in part other similar actions, provided *all* these actions are not required to be used, appear to be unaffected.

The ability of the operator to send with either hand would lessen the liability to this disease.

Crater in Positive Carbon.—A depression at the end of the positive carbon of an arc lamp which appears when a voltaic arc is formed. (See *Arc, Voltaic.*)

Creep, Diffusion — —The flow of an electric current in portions of a conducting substance, outside the parts that lie in the direct lines between the points where the terminals of the same are applied to the conducting substance.

Creeping, Electric — —A term sometimes applied to the creeping of a current. (See *Current, Creeping of*.)

Creeping in Voltaic Cell.—(See *Cell, Voltaic, Creeping in*.)

Creeping of Current.—(See *Current, Creeping of, Electric*.)

Creeping, Saline — —The formation of salts by efflorescence on the walls of a solid immersed in a solution of a salt.

Creosoting.—A process employed for the preservation of wood, as, for example, telegraph poles, by injecting creosote into the pores of the wood. (See *Pole, Telegraphic*.)

Crith.—A term proposed by A. W. Hoffman, as a unit of weight, or the weight of one litre, or cubic decimetre, of hydrogen at 0° C. and 760 mm. barometric pressure.

Critical Current. — (See *Current, Critical*.)

Critical Current of a Dynamo.—(See *Current, Critical, of a Dynamo*.)

Critical Distance of Lateral Discharge through Alternative Path.—(See *Distance, Critical, of Lateral Discharge through an Alternative Path*.)

Critical Speed of Compound-Wound Dynamo.—(See *Speed, Critical, of Compound-Wound Dynamo*.)

Crookes' Dark Space.—(See *Space, Dark, Crookes'*.)

Crookes' Electric Radiometer.—(See *Radiometer, Electric, Crookes'*.)

Cross Arm.—(See *Arm, Cross*.)

Cross-Connecting Board.—(See *Board, Cross-Connecting*.)

Cross, Electric — —A connection, generally metallic, accidentally established between two conducting lines.

A defect in a telegraph, telephone or other circuit caused by two wires coming into contact by crossing each other.

A *swinging or intermittent cross* is caused by wires, which are too slack, being occasionally blown into contact by the wind.

A *weather cross* arises from defective action of the insulators in wet weather.

Cross, Swinging or Intermittent — — An accidental contact, generally metallic, caused by wires being brought into occasional contact with one another, or with some other conductor, by the intermittent action of the wind.

Cross, Weather — —A contact or leak occurring in a telegraphic or other line during wet weather, from the defective action of the insulators.

Crossing Cleat.—(See *Cleat, Crossing*.)

Crossing, Live-Trolley — —A device whereby a trolley moving over a line that crosses a second line at an angle is enabled to maintain its electrical connection with the line while crossing.

A live-trolley crossing is necessitated where one line of electric railway crosses another. The upper line must, of course, provide a space or opening for crossing the lower line at the points of intersection. This is effected in the Bagnall live-trolley crossing, shown in Fig. 175, by attach-



Fig. 175. Live-Trolley Crossing.

ing to the upper trolley wire a bridge piece of light lathe casting, provided at its centre with a gap through which the trolley wire passes. This bridge piece is insulated from the trolley wire by means of a disc of insulating material at the centre of the bridge, which is provided with a hinged curved lever, that in its normal position rests under the influence of gravity in the position shown in the figure. The passage of the trolley wheel along the wire carries the line under it and thus bridges the gap, as shown by the position of the dotted lines.

Crossing Wires.—(See *Wires, Crossing*.)

Cross-Over Block.—(See *Block, Cross-Over*.)

Cross-Over, Trolley — —A device by means of which a trolley is enabled to pass over the points where different lines cross one another without serious interruption.

A trolley cross-over, for trolley lines, is shown in Fig. 176.



Fig. 176. Trolley Cross Over.

Crow-foot Zinc.—(See *Zinc, Crow-foot.*)

Crucible, Electric — —A crucible in which the heat of the voltaic arc, or of electric incandescence, is employed either to perform difficult fusions, or for the purpose of effecting the reduction of metals from their ores or the formation of alloys. (See *Furnace, Electric.*)

Crystal.—A solid body bounded by symmetrically disposed plane surfaces.

A definite form or shape is as characteristic of an inorganic crystalline substance as it is of an animal or plant. Each substance has a form in which it generally occurs. There are, however, certain modifications of the typical forms which cause plane surfaces to appear curved, and the symmetrical arrangement of the faces to disappear. These modifications often render it extremely difficult to recognize the true typical form.

For the different fundamental crystalline forms, or systems of crystals, see any standard work on chemistry.

Crystal, Hemihedral — —A crystal whose shape or form has been modified by the replacement of half its edges or solid angles.

A hemihedral crystal possesses different forms at the ends or extremities of its axes. Hemihedral crystals, when unequally heated, develop electrical charges.

Electricity produced in this way was formerly called *pyro-electricity*. (See *Electricity, Pyro.*)

Crystal, Holohedral — —A crystal whose shape or form has been modified by the replacement of all its edges or solid angles.

Crystalline Electro-Metallurgical Deposit.—(See *Deposit, Crystalline, Electro-Metallurgical.*)

Crystallization.—Solidification from a state of solution or fusion in a definite crystalline form.

The crystallization of a dissolved solid is favored by any cause that gives increased freedom of movement to its molecules, such for example as *solution, fusion, sublimation, or precipitation*.

Crystallization by Electrolytical Decomposition.—The crystalline deposition of various metals by the passage of an electric current through solutions of their salts under certain conditions.

A strip of zinc immersed in a solution of sugar of lead (acetate of lead) soon becomes covered with bright metallic plates of lead, that are electrolytically deposited by the weak currents due to minute *voltaic couples* formed with the zinc by particles of iron, carbon, or other impurities in the zinc. The deposit assumes at times a tree-like growth, and is therefore called a *lead tree*. (See *Couple, Voltaic.*)

Crystallization, Electro — —Crystallization effected during electrolytic deposition.

Crystallize.—To separate from a liquid or vapor, in the form of a crystalline solid.

Crystalloid.—Those portions of a mixed substance subjected to dialysis, that are capable of crystallization. (See *Dialysis.*)

Cube, Faraday's — —An insulated room, cubic in shape, covered on the inside with tin foil, which, when charged on the outside gives no indications to an observer on the inside, though furnished with delicate instruments.

Faraday's cube illustrates the fact that an electrostatic charge resides on the outside of an insulated conductor. (See *Net, Faraday's.*)

Cup, Mercury — —A cup or cavity filled with mercury and connected with the pole of an electric apparatus for the ready placing of the same in circuit with other electric apparatus.

To connect apparatus it is only necessary to insert the free terminal of one apparatus in the mercury cup of the other.

Cup, Porous — —A porous cell. (See *Cell, Porous.*)

Curb, Double — —A device for increasing the speed of signaling, by means of which the line is rid of its charge before the next signal is sent, by sending an opposite charge, then another in the same direction,

then finally another in the same direction before connecting with the ground.

The effect of the third charge is to reduce the potential of the line more nearly to zero at the end of the signal.

Curb, Single — —A device for increasing the speed of signaling telegraphically by ridding the line of its previous charge by sending a reversed current through it before connecting with the ground.

In single-curb signaling the operator in discharging the line before sending another signal through it, before putting the line to earth, reverses the battery, and then connects to earth.

Current, Absolute Unit of — —A current of 10 ampères. (See *Ampère, Units, Practical*.)

A current of such a strength that when passed through a circuit of a centimetre in length bent in the form of an arc of a circle one centimetre in radius, will act with the force of a dyne on a magnetic pole of unit strength, placed at the centre of the arc.

The ampère, the practical unit of current, is but $\frac{1}{10}$ the value of the absolute unit of current.

Current, Action of, on a Magnetic Pole — —An attraction or repulsion dependent on the name of the pole and the direction of the current.

Two currents of electricity attract or repel each other according to the direction in which they are flowing, and the mutual positions of their circuits. A current and a magnetic pole exert an action on each other which, strictly speaking, is neither attraction nor repulsion, but which is rotation, that may, however, be regarded as being produced by the combined action of attraction and repulsion.

Current, Alternating — —A current which flows alternately in opposite directions.

A current whose direction is rapidly reversed.

The non-commuted currents generated by the differences of potential in the armature of a dynamo-electric machine are alternating or simple-periodic-currents.

In a characteristic curve of the electromotive forces of alternating currents, positive electromotive forces, or those that would produce cur-

rents in a certain direction, are indicated by values *above* a horizontal line, and negative electromotive forces, by values *below* the line.

The curves A B C, and C D E, Fig. 177, are

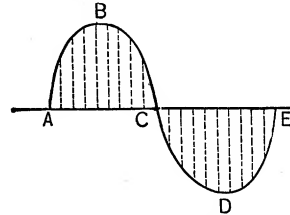

Fig. 177. Curve of Electromotive Forces of Alternating Currents.

often called *phases*, and represent the alternate phases of the current.

Current, Alternative — —A voltaic alternative. (See *Alternatives, Voltaic*.)

Current, Assumed Direction of Flow of — —The direction the current is assumed to take, *i. e.*, from the positive pole of the source through the circuit to the negative pole of the source.

The electricity is assumed to come out of the source at its positive pole, and to return or flow back into the source at its negative pole. This convention as to the direction of the electric current is in accordance with the assumption of the direction of flow of lines of magnetic forces.

The old idea of a dual or double current flowing in opposite directions is still maintained by some. (See *Force, Lines of, Direction of*.)

Current, Axial — —In electro-therapeutics a current flowing in a nerve in the opposite direction to the normal impulse in the nerve.

Current, Break-Induced — —The current induced by a current in its own, or in another circuit, on breaking or opening the same.

The current induced in the secondary on the breaking of the primary circuit.

The break-induced current set up by a current in its own circuit is sometimes called the *direct-induced* current.

Lord Rayleigh has shown that within certain limits the break-induced current has a greater effect in magnetizing steel needles, the smaller the number of turns of wire in the secondary. In

the case of a galvanometer, it is well known that the opposite is true. The deflection of the galvanometer needle depends on the strength of the whole current. The magnetizing power depends, for the greater part, on the strength of the current at the beginning of its formation.

Current, Closed-Circular — — A current flowing in a circular circuit.

A small closed-circular current may be replaced magnetically by a thin disc of steel, magnetized in a direction perpendicular to its face, and the edge of which corresponds to the edge of the circular conductor.

Current-Commuter. — (See *Commuter, Current*.)

Current, Conduction — — The current that passes through a metallic or other conducting substance, as contradistinguished from a current produced in a non-conductor or dielectric. (See *Current, Displacement*.)

Current, Constant — — A current that continues to flow in the same direction for some time without varying in strength.

This term is sometimes used to mean a continuous or direct current in contradistinction to an alternating current, but it ought to be applied only to unvarying currents, such, for example as a constant current of 10 ampères.

Current, Continuous — — An electric current which flows in one and the same direction.

Although the term continuous current is used as synonymous with constant current, it is not entirely so; a continuous current flows constantly in the same direction. A constant current not only flows continuously in the same direction, but maintains an approximately constant current strength.

This term continuous current is used in the opposite sense to alternating current, and in the same sense as a direct current.

Current, Creeping of Electric — — A change in the direction of path of a current from the direct line between the points of connection with the source.

When the terminals of any electric source are placed in contact with any two points of a metallic sheet of conducting material, the flow of the current is not confined to the direct line between the

points of contact, but creeps or diffuses into portions of the conducting plate surrounding this direct line. (See *Current, Diffusion of*.)

In a somewhat similar manner, the current is said to creep, or to establish a partial short-circuit around the poles of a poorly insulated voltaic battery, or other electric source.

Current, Critical —

— The current at which a certain result is reached.

Current, Critical, of a Dynamo — — That value of the current at which the characteristic curve begins to depart from a nearly straight line. — (*Silvanus P. Thompson*.)

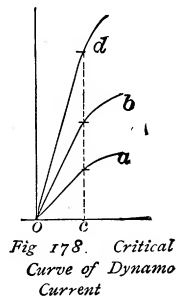

In Fig. 178 the critical current is shown in three different cases, as occurring where the dotted vertical line cuts the characteristic curves.

The speed at which a series dynamo excites itself is often called the *critical speed*.

Current, Demarcation — — A term sometimes applied to an electric current obtained from an injured muscle.

“Every injury of a muscle or nerve causes at the point of injury a dying surface, which behaves negatively to the positive intact substance.” — (*Landois & Stirling*.)

Current Density. — The current of electricity which passes in any part of a circuit as compared with the area of cross-section of that part of the circuit.

In a dynamo-electric machine the current density in the armature wire should not, according to Silvanus P. Thompson, exceed 2,500 ampères per square inch of area of transverse section of conductor.

The current density in a dynamo wire, of necessity, depends on the sectional area of the coils. If, for example, a current of 50 ampères be safe in an armature section of eight turns it may be safely increased to 100 ampères if the conductors are cross-sectioned so as to make but four turns. — (*Urquhart*.)

In electro-plating, for every definite current strength that passes through the bath, or in other words, for a definite number of coulombs, a definite weight of metal is deposited, the charac-

ter of which depends on the current density. The character of an electrolytic deposit will therefore depend on the *current density* at that part of the circuit where the deposit occurs.

The following table from Urquhart gives the practical working value for the current density for electro-metallurgical deposits :

CURRENT DENSITY (OR AMPÈRES ON CATHODE).	
Solution of	Ampères per square foot.
Copper, acid bath.....	5.0 to 10.0
Copper, cyanide bath.....	3.0 " 5.0
Silver, double cyanide.....	2.0 " 5.0
Gold, chloride in cyanide.....	1.0 " 2.0
Nickel, double sulphate.....	6.0 " 8.0
Brass, cyanide.....	2.0 " 3.0
Tin.....	...

Current, Diacritical — —Such a strength of the magnetizing current as produces a magnetization of an iron core equal to half-saturation.

The diacritical current is the current which, flowing through the diacritical number of ampère-turns, will bring up the magnetism produced to half-saturation.

The diacritical number of ampère-turns is such a number of ampère-turns as would reduce the magnetic permeability to half its full value.

Current, Diffusion of — —A term employed to designate the difference in the density of current in different portions of a conductor. (See *Current, Creeping of, Electric*.)

Current, Diffusion of Electro-Therapeutic — —The difference in the density of current in different portions of the human body between the electro-therapeutic electrodes.

When the electrodes are placed at any two given points of the human body, the current branches through various paths, extending in a general direction from one electrode to the other, according to the law of branched or derived circuits, and flowing in greater amount, or with greater density of current, through the relatively better conducting paths. (See *Current Density*.)

This is sometimes called the creeping of the current. (See *Current, Creeping of*.)

Current, Direct — —A current con-

stant in direction, as distinguished from an alternating current.

A continuous current.

Current, Direct-Induced — —The current induced in a circuit by induction on itself, or self-induction, on breaking or opening the circuit. (See *Currents, Extra*.)

This is called the direct-induced current because its direction is in the same direction as the inducing current.

Current, Direction of — —The direction an electric current is assumed to take out from one pole of any source through the circuit and its translating devices back to the source through its other pole.

Conventionally, the current is assumed to come out from the positive pole of the source and to go back to the source at the negative pole.

Current, Displacement — —The rate of change of electric displacement.

A brief conduction current produced in a dielectric by an electric displacement. (See *Displacement, Electric*.)

This is called a displacement current in order to distinguish it from a conduction current in any conductor.

The displacement current continues while the displacement of electricity is going on. Displacement currents have all the properties of conduction currents, and, like the latter, produce a magnetic field; in fact, they resemble extremely brief conduction currents.

The difference between conducting substances and dielectrics, lies in the fact that the conducting substances do not possess an elastic force, enabling them to resist electric displacement. In other words, conducting substances possess no *electric elasticity*, and can have no true displacement current established in them. (See *Elasticity, Electric*.)

A displacement current, like a conduction current, possesses a magnetic field, or is encircled by lines of magnetic force. (See *Field, Magnetic, of an Electric Current*.)

Current, Electric — —The quantity of electricity which passes per second through any conductor or circuit.

The rate at which a definite quantity of electricity passes or flows through a conductor or circuit.

The ratio existing between the electromotive force, causing the current, and the resistance which may, for convenience, be regarded as opposing it, expressed in terms of quantity of electricity per second.

The *unit of current*, or the *ampère*, is equal to *one coulomb per second*. (See *Ampère. Coulomb.*)

The word current must not be confounded with the mere act of flowing; electric current signifies rate of flow, and always supposes an electromotive force to produce the current, and a resistance to oppose it.

The electric current is assumed to flow out from the positive terminal of a *source*, through the circuit and back into the source at the *negative terminal*. It is assumed to flow into the positive terminal of an *electro-receptive* device such as a lamp, motor, or storage battery, and out of its negative terminal; or, in other words, the positive pole of the source is always connected to the positive terminal of the electro-receptive device.

Professor Lodge draws the following comparison between the motions of ordinary matter, heat and electricity: "Consider the modes in which water may be made to move from place to place; there are only two. It may be pumped along pipes, or it may be carried about in jugs. In other words, it may travel through matter, or, it may travel with matter. Just so it is with heat, also. Heat can travel in two ways: it can flow through matter, by what is called 'conduction,' or, it can travel with matter, by what is called 'convection.' There is no other mode of conveyance of heat." * * * "For electricity the same is true. Electricity can travel with matter, or it can travel through matter, by convection, or by conduction, and by no other way."

In the above, the radiation of heat is apparently lost sight of.

In the opinion of some, an electric current consists of two distinct currents, one of positive and the other of negative electricity, flowing in opposite directions. Each of these currents is supposed to be equal in amount to the other.

The electric current is now regarded as passing through the dielectric surrounding the conductor, rather than through the conductor itself. (See *Current, Electric, Method of Propagation of, Through a Circuit.*)

The current that flows or passes in any circuit is, in the case of a constant current, equal to the

electromotive force, or difference of potential, divided by the resistance, as—

$$C = \frac{E}{R}.$$

(See *Law of Ohm.*)

Current, Electric, Method of Propagation of, Through a Circuit — — When an electric current is propagated through a wire or other conductor, it is not sent or pushed through the conductor, like a fluid through a pipe or other conductor, but is, so to speak, rained down on the surface of the conductor from the medium or dielectric surrounding it.

Poynting, who has carefully studied this matter, remarks as follows, viz.: "A space containing electrical currents may be regarded as the field where energy is transformed at certain points into the electric or magnetic kind, by means of batteries, dynamos, thermopiles, etc., and in other parts of the field this energy is being again transformed into heat, work done by the electro-magnetic forces, or any other form yielded by currents."

"Formerly the current was regarded as something traveling in the conductor, and the energy which appeared at any part of the circuit was supposed to be conveyed thither through the conductor by the current. But the existence of induced currents and electro-magnetic actions have led us to look on the medium surrounding the conductor as playing a very important part in the development of the phenomena. If we believe in the continuity of the motion of energy, we are forced to conclude that the surrounding medium is capable of containing energy, and that it is capable of being transferred from point to point. We are thus led to consider the problem, how does the energy about an electric current pass from point to point; by what paths does it travel, and according to what laws? Let us take a specific case. Suppose a dynamo at one spot generates an electric current, which is made to operate an electric motor at a distant place. We have here, in the first place, an absorption of energy from the prime motor into the dynamo. We find the whole space between and around the conducting wires magnetized and the seat of electro-magnetic energy. We have further a retransformation of energy in the motor. The question which presents itself for solution is to decide how the energy taken up by the dynamo is transmitted to the motor, by what path it travels

and according to what laws? Briefly stated, the tendency of recent views is that this energy is conveyed through the electro-magnetic medium or ether, and that the function of the wire is to localize the direction or to concentrate the flow in a particular path, and thus provide a *sink* or place in which the energy can be dissipated. * * *

Taking again, for instance, the case of the discharge of a condenser by a conductor. He says: "Before the discharge we know that the energy resides in the dielectric, between the conducting plates. If these plates are connected by a wire, according to these views, the energy is transferred outwards along the electrostatic, equipotential surfaces, and moves *on* to the wire and is there converted into heat. According to this view we must suppose the lines of electrostatic induction, running from plate to plate, to move outwards, as the dielectric strain lessens, and while still keeping their ends on the plates, to finally converge in on the wire and be there broken up and their energy dissipated as heat."

In other words, some of the energy of the expanding lines of induction is changed into magnetic energy; this energy is contained in ring-shaped tubes of force, which expand outwards from between the plates and then contract on some other part of the conductor.

The time of the discharge, then, consists of the following steps, viz.:

(1.) The time during which the energy of the charge is nearly all electrostatic and is represented by the energy contained in the lines or tubes of electrostatic induction, running from plate to plate of the condenser.

(2.) The time during which the discharge is at its maximum and the energy consists of two parts, viz.: energy associated with the outward expanding lines of electrostatic induction, and energy associated with the closed lines or tubes of magnetic force, which at first are expanding and afterwards contracting.

(3.) The time when the energy has been absorbed, or the period in which the energy in the wire or the conductor has either been dissipated in the form of non-luminous radiation or obscure heat.

(4.) The time during which this non-luminous heat gives up its energy again to the surrounding medium in the shape of heat waves.

Current, Electro-Therapeutic Polarizing
—The current which produces the

phenomena of electrotonus. (See *Electrotonus*.)

Current, Element of — —A term employed in mathematical discussions to indicate a very small part of a current for ease in considering its action on a magnetic needle or other similar body.

Current, Faradic — —In electro-therapeutics, the current produced by an induction coil, or by a magneto-electric machine.

A rapidly alternating current, as distinguished from a uniform voltaic current.

A voltaic current that is rapidly alternated by means of any suitable key or switch is sometimes called a *voltaic alternative*. The discharge from a Holtz machine is sometimes called a *Franklinic Current*. (See *Alternatives, Voltaic Current, Franklinic*.)

Current-Filaments. — (See *Filament, Current*.)

Current, Franklinic — —A term sometimes used in electro-therapeutics for a current produced by the action of a frictional electric machine.

The term, Franklinic current, is used in contradistinction to Faradic current, or that produced by induction coils, or, in contradistinction to a galvanic or voltaic current, or that produced by a voltaic battery.

Current, Generation of, by Dynamo-Electric Machine — —The difference of potential developed in the armature coils by the cutting of the lines of magnetic force of the field by the coils, during the rotation of the armature.

If a loop of wire whose ends are connected to the two-part commutator, shown in Fig. 179, be

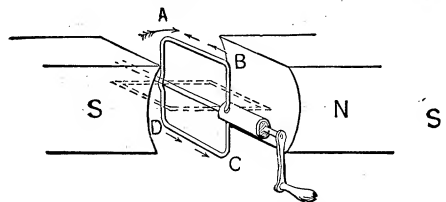

Fig. 179. Induction in Armature Loop.

rotated in the magnetic field between the magnet poles N and S, in the direction of the large arrow, differences of potential will be generated which

will cause currents to flow in the direction indicated by the small arrows during its motion past the north pole from the top to the bottom, but in the opposite direction during its motion past the south pole—from the bottom to the top. If, now, collecting brushes rest on the commutator in the positions shown in the Fig. 180. the vertical line

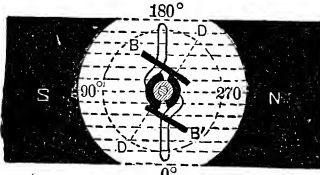

Fig. 180. Action of Commutator.

of the gap between the poles corresponding with the vertical gap between the commutator segments, the currents generated in the loop will be caused to flow in one and the same direction, and B', will become the positive brush, since the end of the loop is connected with it only so long as it is positive. As soon as it becomes negative, from the current in the loop flowing in the opposite direction, the other end, which is then positive, is connected with the positive brush.

A similar series of changes occur at the negative brush B.

Theoretically, the neutral points, where the brushes rest, would be in the vertical line coinciding with that of the gap between the poles. An inspection of the figure shows that the *neutral line*, or the *diameter of commutation*, is displaced in the direction of rotation. (See *Commutation, Diameter of.*) The displacement of the brushes, so necessitated, is called the *Lead*.

The cause of the lead is the reaction that occurs between the magnetic poles of the field magnets

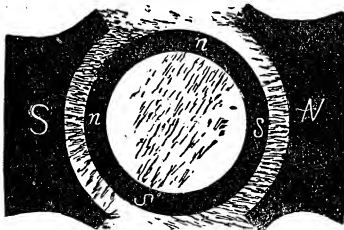

Fig. 181 Cause of Lead of Brushes.

and those of the armature, the result of which is to displace the field magnet poles, and to cause a change in the density in the field. This is shown in Fig. 181, where the density of the lines of force indicates the position of the diameter of commu-

tation as being near, or at right angles to the diameter of greatest average magnetic density. (See *Lead, Angle of. Lag, Angle of.*)

Current-Governor.—(See *Governor, Current.*)

Current, Homogeneous Distribution of

—Such a distribution of a current through any conductor in which there is an equal density of current at all portions of any cross-section of the conductor.

When the flow of a constant current is established in a solid conducting wire, there is a homogeneous distribution of current in that conductor.

Current, Induced — —The current produced in a conductor by cutting lines of force.

The induced current results from differences of potential produced by electro-dynamic induction. (See *Induction, Electro-Dynamic.*)

Current-Induction. — (See *Induction, Current.*)

Current, Intensity of — —An old term sometimes employed to indicate the current which resulted from a considerable difference of potential, or a great electromotive force.

This term was also formerly used as synonymous with strength of current.

This use of the term is now abandoned.

Voltaic batteries, connected in series so as to give a considerable difference of potential, were spoken of as being connected for *intensity*.

This term has also been used for the quantity of electricity conveyed per second across a unit area of cross-section.

Intensity of current is more properly called density of current. (See *Current Density.*)

Current, Intermittent — —A current that does not flow continually, but which flows and ceases to flow at intervals, so that electricity is practically alternately present and absent from the circuit.

Current, Inverse-Secondary — —The make-induced current. (See *Current, Make-Induced.*)

Current, Jacobi's Unit of — —Such a current that when passed through a voltmeter will liberate a cubic centimetre of

oxygen and hydrogen at 0 degrees C. and 760 mm. barometric pressure.

One Jacobi's unit of current equals $\frac{1}{10.32}$ ampère. (Obsolete.)

Current, Make-Induced — —The current induced by a current in its own circuit on making or closing the same.

The current produced in the secondary of an induction coil on the making or completion of the circuit of the primary.

The make-induced current is also called the inverse-secondary current, because its direction is opposite to that of the inducing current.

Current, Make or Break Induced, Duration of — —The time during which the induced inverse or direct-secondary currents continue.

Blaserna made a number of experiments, which he claims shows :

(1.) The greater the distance apart of the primary and the secondary, that is, the less their mutual-induction, the less the maximum value of the secondary current, and the greater the delay in establishing that maximum.

(2.) The delay in establishing the maximum of the break or direct-secondary current is not as great as in the case of the make, or inverse-secondary current.

(3.) When the coils are near together, the induced currents at starting are established by a series of electric oscillations.

(4.) The primary current establishes itself by a series of electrical oscillations.

(5.) That the interposition of dielectric substances, such as glass between the coils, reduces the time between the making or breaking of the primary current and the beginning of the secondary current. This last conclusion was negatived by some experiments of Bernstein.

Blaserna determined in the case of certain experiments the following value for the durations of the secondary currents :

Inverse-secondary current lasts .000485 second.

Direct-secondary current lasts .000275 second.

Helmholtz contradicts the results of Blaserna, and asserts :

(1.) That no perceptible difference in the zero points of the currents is produced by varying the distance between the primary and secondary.

(2.) That the sparks produced by the breaking

of the primary last for an appreciable time, something like $\frac{1}{15000}$ to $\frac{1}{40000}$ of a second.

(3.) The duration of the break-spark is never constant, but depends in great part on the amount of platinum given off from the contacts at each spark.

Current-Meter.—A form of galvanometer. (See *Galvanometer*.)

Current, Momentary — —A current that continues to flow but for a short time.

Current, Multi-Phase — —A rotating current. (See *Current, Rotating*.)

Current, Muscle — —In electro-therapeutics, the current flowing through a muscle.

Muscle currents are produced either by stimulation, or during activity of a muscle. According to L. Hermann, uninjured muscles, or perfectly dead muscles, yield no currents, but such currents result only from an injury. (See *Current, Demarcation*.)

Current, Non-Homogeneous Distribution of — —Such a distribution of current passing through a conductor in which there is an unequal density of current at all portions of any cross-section of the conductor.

When a rapidly alternating current is passed through any solid conductor, the current density is greater at the surface and less towards the centre. The current distribution in such a conductor is non-homogeneous, and the want of uniformity of current density is greater as the rapidity of alternation or periodicity is greater.

Current, Outgoing — —The current sent out over the line from a station provided with a duplex or quadruplex transmission, as distinguished from the received current. (See *Current, Received*.)

Current, Periodic — —A simple periodic current. (See *Currents, Simple Periodic*.)

Current, Periodic, Power of — —An amount of work, per second, equal to the product of the electromotive force taken at successive moments of time during a complete cycle, multiplied by the current strength taken at the corresponding moments during the cycle.

Since the electromotive force and current in

a periodic circuit may be represented by two simple harmonic functions, the mean value of the two, when of different amplitude and phase, is equal to the product of their maximum value by the cosine of their difference of phase divided by two.

Current, Polarization — —In electrotherapeutics, the constant current which when passed through a nerve produces in it the electrotonic state. (See *Electrotonus*.)

Current, Pulsating — —A pulsatory current. (See *Current, Pulsatory*.)

Current, Pulsatory — —A current, the strength of which changes suddenly.

The pulsatory current usually consists of sudden and distinct impulses, or rushes of current, in contradistinction to an undulatory or harmonically varying current.

Current, Received — —The current received from the distant end of the line at a station provided with a duplex or quadruplex transmission as distinguished from the outgoing current.

A term sometimes used in telegraphy to distinguish between currents that come in over the line from a distant station, and those that are sent out to a distant station.

Current, Rectilinear — —A current flowing through straight or rectilinear portions of a circuit.

In studying the effects of the attractions or repulsions produced by electric currents the name expressing the peculiarity of shape of any part of the circuit is often applied to the current flowing through that part of the circuit. Thus we speak of a rectilinear current, a sinuous current.

Current, Reverse-Induced — —The current induced by a current in its own circuit at the moment of making or closing the circuit.

The current induced in the secondary on closing or making the circuit of the primary.

This is called the reverse-induced current, because its direction is opposite to that of the current in the inducing circuit.

Current, Reversed — —A current whose direction is changed at intervals. (See *Current, Alternating*.)

Current Reverser.—(See *Reverser, Current*.)

Current, Reversing a — —Changing the direction of an electric current.

Current, Rotating — —A term applied to the current which results by combining a number of alternating currents, whose phases are displaced with respect to one another.

A rotating current is sometimes called a polyphase or *multiple-phase current*, particularly if there are three or more currents combined.

The rotating current is employed by Tesla, Dobrowolsky and others in a system of distribution by transformers in place of the ordinary alternating current. In practice, three alternating current are combined. The currents and their combination are obtained by means of a specially constructed alternator. When three currents are combined the displacement between each set of phases is 120 degrees. A rotating current, unlike an alternating current, possesses, in a certain sense, a definite direction of flow. Its effect on a magnetic needle is to cause rotation. Hence motors constructed on the principle of rotating currents will start with a load.

Current, Rotatory-Phase-Alternating — —A term sometimes employed for a rotating electric current. (See *Current, Rotating*.)

Current, Secretion — —In electrotherapeutics, a current following stimulation of the secretory nerves.

Current, Simple-Harmonic — —A term sometimes used instead of simple-periodic current. (See *Currents, Simple Periodic*.)

Current, Sinuous — —A term sometimes applied to currents flowing through a sinuous conductor.

Sinuous currents exert the same effects of attraction or repulsion on magnets, or on neighboring circuits, as would a rectilinear current whose length is that of the axis of such sinuous current.

This can be shown by approaching the circuit A' B', Fig. 182, consisting of the sinuous conductor A', and rectilinear conductor B', to the movable conductor A B C, on which it produces no effect. The current A', therefore, neutral-

izes the effects of the current B'; or, it is equal to it in effect.

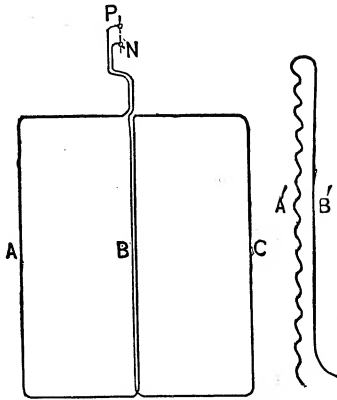

Fig. 182. Rectilinear Equivalent of Sinuous Current.

In calculating the effects of sinuous currents it is convenient to consider them as consisting of a

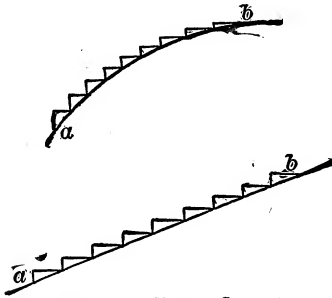

Fig. 183. Sinuous Currents.

succession of short, straight portions at right angles to one another, as shown in Fig. 183.

Current, Steady — — A current whose strength does not vary from time to time.

In a steady current the quantity of electricity flowing through each unit of area of the equipotential surface of the conductor is the same for each succeeding interval of time. Such a current is sometimes called a *uniformly distributed current*.

Current Streamlets.—(See *Streamlets, Current*.)

Current Strength.—The product obtained by dividing the electromotive force by the resistance.

The current strength for a constant current according to Ohm's law is—

$$C = \frac{E}{R}$$

Current strength is proportional to the amount of the magnetic or chemical (electrolytic) effects it is capable of producing.

For a simple-periodic current, the current strength necessarily varies from time to time.

The average current strength of a simple-periodic current is equal to the average impressed electromotive force divided by the impedance. (See *Impedance*.)

The maximum current strength is equal to the maximum impressed electromotive force divided by the impedance.

Current, to Transform a — — To change the electromotive force of a current by its passage through a converter or transformer.

To convert a current.

Current, Transforming a — — Changing the electromotive force of a current by its passage through a converter or transformer.

Current, Undulating — — An undulatory current. (See *Currents, Undulatory*.)

Current, Uniformly-Distributed — — A term sometimes employed in the same sense as steady current. (See *Current, Steady*.)

Current, Unit Strength of — — Such a strength of current that when passed through a circuit one centimetre in length, arranged in an arc one centimetre in radius, will exert a force of one dyne on a unit magnet pole placed at the centre.

This absolute unit is equal to ten ampères or practical units of current. (See *Ampère*.)

Current, Variable Period of — — The period which exists while an electric current is being increased or decreased in strength, or while it is being reversed.

Currents, Action — — Physiological currents obtained during the activity of a muscle or nerve.

Currents, After — — In electro-therapeutics, currents produced in nervous or muscular tissue when a constant current, which has been flowing through the same, has been stopped.

After currents are due to internal polarization.

Currents, Alternating-Primary — — The currents employed in the primary of a

transformer to induce alternating currents in the secondary. (See *Transformer*.)

Currents, Alternating-Secondary — — The currents induced in the secondary of a transformer by the alternating currents in the primary. (See *Transformer*.)

Currents, Alternating, Shifting of Phase of — — (See *Phase, Shifting of, of Alternating Currents*.)

Currents, Ampèrian — — The electric currents that are assumed in the ampèrian theory of magnetism to flow around the molecules of a magnet. (See *Magnetism, Ampère's Theory of*.)

The ampèrian currents are to be distinguished from the *eddy, Foucault, or parasitical currents*, since, unlike them, they are directed so as to produce useful effects. (See *Currents, Eddy*.)

It is not believed that the ampèrian currents are produced in magnetizable substances by the act of magnetization. The atoms or molecules were magnetic originally. All the magnetizing force does is to arrange the molecules or atoms, or to set them in one and the same direction.

Currents, Angular — — Currents flowing through circuits that cross or are inclined to one another at any angle. (See *Dynamics, Electro*.)

Currents, Atomic — — A term sometimes used instead of molecular or ampèrian currents. (See *Currents, Ampèrian*.)

Currents, Attractions and Repulsions of — — The mutual attractions or repulsions exerted by currents on one another through the interaction of their magnetic fields. (See *Dynamics, Electro*.)

Currents, Commuted — — Electric currents that have been caused to flow in one and the same direction. (See *Commutator*.)

Currents, Commuting — — Causing several currents to flow in one and the same direction.

Currents, Component — — The two or more currents into which it may be conceived that a single current can be divided, so as to produce the same effects of attraction or repulsion that the single current would do.

The idea of component currents is based on the similar idea of the components of any single force.

Currents, Continuity of — — The freedom from variation in current strength or current direction.

Currents, Convection — — Currents produced by the bodily carrying forward of static charges in convection streams. (See *Streams, Convection*.)

In a convection current, the static charge is bodily carried forward.

Rowland has shown experimentally that a moving electric charge is the equivalent of an electric current. He rotated a gilded ebonite disc between two gilt glass discs, near which were placed a number of delicate magnetic needles. When certain rapidity of rotation was obtained, the discs were found to affect the magnetic needles the same as would a current of electricity flowing in a circular conductor, whose form coincided with the periphery of the disc.

Currents, Converted — — Electric currents changed either in their electromotive force or in their strength, by passage through a converter or transformer. (See *Transformer*.)

Currents, Converting — — Changing the electromotive force of currents by their passage through a converter or transformer. (See *Transformer*.)

Currents, Diaphragm — — Electric currents produced by forcing a liquid through the capillary pores of a diaphragm. (See *Osmose, Electric*.)

Currents, Earth — — Electric currents flowing through the earth, caused by a difference of potential at different parts.

The causes of these differences of potential are various and are not well understood.

Currents, Eddy — — Useless currents produced in the pole pieces, armatures, field-magnet cores of dynamo-electric machines or motors, or other metallic masses, either by their motion through magnetic fields, or by variations in the strength of electric currents flowing near them.

Sensible eddy currents are produced in the mass

of the conducting wire on the armature of a dynamo-electric machine when the wire is comparatively heavy.

Such currents are called *eddy currents*, *local currents*, *Foucault currents*, or *parasitical currents*. They form closed-circuits of comparatively low resistance, and tend to cause undue heating of armatures or pole pieces. They not only cause a

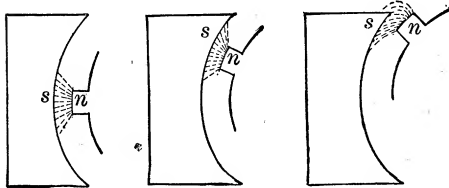

Fig. 184. Foucault Currents in Pole Pieces.

useless expenditure of energy, but interfere with the proper operation of the device.

To reduce them as far as practicable, the pole pieces, armature cores or armature wires, are laminated. (See *Core, Lamination of*.)

These local currents are perhaps preferably called Foucault currents when they take place in magnetic cores, pole pieces or armature cores, and eddy currents when they occur in the armature wire or conductor. When the armature conductor is made up of copper bars, for example, the eddy currents in the latter are usually considerable.

Since Foucault currents in dynamo-electric machine cores are due to variations in the magnetic

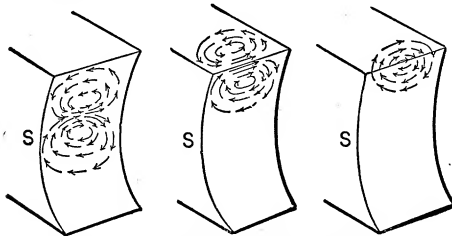

Fig. 185. Foucault Currents in Pole Pieces.

strength of the field magnets, or of the armature, they will be of greatest intensity when the changes in the magnetic strength are the greatest and most sudden.

These changes are most marked, and consequently the Foucault currents are strongest at those corners of the pole pieces of a dynamo from which the armature is moved in its rotation, as will be seen from an inspection of Fig. 184.

Fig. 185, shows Foucault currents generated in pole pieces.

Currents, Eddy-Conduction — — A term employed for ordinary eddy currents in conductors, in order to distinguish them from eddy-displacement currents. (See *Currents, Eddy-Displacement*.)

Currents, Eddy Deep Seated — — Eddy currents set up in the mass of a conductor subjected to electro-dynamic induction in contradistinction to superficially seated eddy currents. (See *Currents, Eddy, Superficial*.)

Currents, Eddy-Displacement — — Eddy currents produced in the mass of a dielectric or insulator, when lines of magnetic or electrostatic force pass through the dielectric or insulator.

Eddy-displacement currents are produced in a dielectric or non-conductor, when it is moved across a magnetic field, so as to cut the lines of magnetic force.

Eddy displacement currents would also occur if a dielectric is subjected to varying electrostatic induction.

Currents, Eddy, Superficial — — Eddy currents produced in conducting substances that are limited to the outer layers thereof.

The eddy currents produced by alternating currents are superficial if the alternating currents are sufficiently rapid. The oscillatory currents produced during the discharge of a Leyden jar are more superficial in proportion as the discharge takes place rapidly. When currents are produced in a magnetizable body by the discharge of a Leyden jar, they are more and more superficial, as the discharge of the jar is more and more rapid. The reason a slow discharge of a jar or condenser produces a greater magnetizing effect is, because of the checking or screening action the superficial eddy currents exert on the interior of the mass of the magnetizable substance when the discharge is very rapid.

Currents, Electrotonic — — In electrotherapeutics, currents due to internal polarization in the nerve fibre between the conducting core of the nerves and the enclosing sheaths.

Currents, Extra — — Currents produced in a circuit by the induction of the current on itself on the opening or closing of

the circuit. (See *Currents, Extra. Induction, Self.*)

The extra current induced on breaking, flows in the same direction as the original current and acts to strengthen and prolong it.

The extra current induced on making or completing a circuit flows in the *opposite direction* to the original current and tends to *oppose or retard* the current.

Both of these currents are called *induced or extra currents*. The former is called the *direct-induced current*, and the latter the *reversed-induced current*. (See *Current, Direct-Induced. Current, Reversed-Induced.*)

In order to distinguish this induction from that produced in a *neighboring conductor* by the passage of the electric current, it is called *self-induction*. (See *Induction, Self. Induction, Mutual.*)

The effect on a telegraphic line of the self-induced or extra currents is to decrease the speed of signaling by retarding the beginning of a signal, and prolonging its cessation.

The greater the number of turns of wire in a circuit, or magnet, and the greater the mass of iron in its core, the greater the strength of the extra currents.

Currents, Foucault — — A name sometimes applied to eddy currents, especially in armature cores. (See *Currents, Eddy.*)

Currents, Heating Effects of — — The heat produced by the passage of an electric current through any circuit. (See *Heat, Electric.*)

Currents, Imbibition — — Currents produced in tissues by the imbibition or absorption of a fluid.

Imbibition currents are a species of diaphragm currents. The absorption of a fluid at the demarcation surface of an injured nerve or muscle, or at the contracted portion of muscles, produces imbibition currents.

Such currents are also produced in plants by the movement of fluids produced by bending the stalk or leaves, or by active movements of certain sensitive plants.

Currents, Induced-Molecular or Atomic — — Currents induced in the atoms or molecules of a magnetizable substance on its being brought into a magnetic field.

These currents are called *induced-molecular or induced-atomic currents* in order to distin-

guish them from the molecular, atomic or ampèrian currents, or the currents which are assumed to be always present. It is by the presence of these assumed induced-molecular currents that the phenomena of diamagnetism are explained by Weber. (See *Diamagnetism, Weber's Theory of.*)

Currents, Local — — A name sometimes applied to eddy currents. (See *Currents, Eddy.*)

Currents, Molecular or Atomic — — A term sometimes employed for ampèrian currents. (See *Currents, Ampèrian.*)

Currents, Natural — — A term sometimes applied to earth currents. (See *Currents, Earth.*)

Currents, Negative — — A term employed in single-needle telegraphy for currents sent over a line in a negative direction by depressing a key that connects the line with the negative pole of a battery and so deflects the needle to the left. (See *Telegraphy, Single-Needle.*)

Currents, Network of — — A term sometimes applied to a number of shunt or derived circuits. (See *Circuit, Shunt. Circuit, Derived. Laws, Kirchoff's.*)

Currents of Motion. — A term sometimes employed in electro-therapeutics for the currents of electricity that traverse healthy muscle or nerve tissue during the sudden contraction or relaxation thereof.

The existence of these currents is denied by some.

Currents of Rest. — A term sometimes employed in electro-therapeutics for the currents of electricity that traverse healthy muscle or nerve tissue while the muscles are passive.

The existence of these currents is denied by some.

Currents, Orders of — — Induced electric currents named from the order in which they are induced, as currents of the first, second, third, fourth, etc., orders.

An induced current can be caused to induce another current in a neighboring circuit, and this a third current, and so on. Such currents are dis-

tinguished by the term, currents of the second, third, fourth, etc., order. (See *Coils, Henry's.*)

Currents, Parasitical — —A name sometimes applied to eddy currents. (See *Currents, Eddy.*)

Currents, Positive — —A term employed in single-needle telegraphy for currents sent over the line in a positive direction by depressing a key that connects the line with the positive pole of a battery and so deflects the needle to the right. (See *Telegraphy, Single-Needle.*)

Currents, Reversed — —A name sometimes applied to alternating currents. (See *Current, Alternating.*)

Currents, Secondary — —The currents produced by secondary batteries in contradistinction to the currents produced by primary batteries.

The currents produced by the secondary conductor of an induction coil, as distinguished from the currents sent into the primaries.

This second use of the term secondary current is more usual.

Currents, Self-Induced — —A current produced by self-induction.

An extra current. (See *Induction, Self-Currents, Extra.*)

Currents, Simple Periodic — —Currents, the flow of which is variable, both in strength and duration, and in which the flow of electricity, passing any section of the conductor, may be represented by a simple periodic curve.

A current of such a nature that the continuous variation of the flow of electricity past any area of cross-section of the conductor, or the variations in the electromotive force of which can be expressed by a simple-periodic or harmonic curve. (See *Curve, Simple-Harmonic.*)

Alternate currents are simple-periodic currents.

The average current strength of simple-periodic currents is equal to the average impressed electromotive force divided by the impedance.

The transmission of rapidly varying or simple-periodic currents through conductors differs very greatly from the transmission of steady cur-

rents. With a steady current, the current density is the same for all areas of cross-section of the conductor. For a rapidly intermittent current, the current density is greater near the surface, and when the rate of intermission is sufficiently great, the current is entirely absent at the centre of the conductor.

Lord Rayleigh has shown that when the rate of intermission is 1,050 per second, the effective resistance of a wire 160 mm. in length, and 30 mm. in diameter, is 1.84 times its resistance to steady currents. He found that the increase of resistance is greater in the case of conductors of great diameter than in those of small diameter.

As regards the character of conductor best suited for transmitting rapidly alternating currents, it can be shown :

(1.) That for transmitting alternate currents of moderate frequency, say of about 1,000 per second, copper conductors should be used in preference to rods of iron.

(2.) That the conductor should be in the form of thin strips, or if tubular, of thin walls.

(3.) That the mere stranding of the conductor, *i. e.*, forming it of separate insulated conductors connected in parallel, will be of no effect in preventing the current from acting on the outside of the conductor, unless the conductor be arranged in the form of a cable, in which one part forms a lead, and another part the return.

Stephan draws the following analogy between the flow of alternating currents in a conductor and the flow of heat in a hot wire :

“Suppose a wire or conductor, uniformly heated from centre to circumference, be suddenly taken into a space where the temperature is high, the outer portions of the wire first rise in temperature, and afterwards the inner portions. In the case of a conductor of circular cross-section, the heat penetrates successive concentric layers. The same phenomena occur when an electromotive force is suddenly set up between the ends of a cylindrical conductor. The current gradually penetrates the conductor from the outside to the centre.

“Now suppose the heated wire is carried into a cooler space, the heat waves pass out radially from the centre towards the circumference. The cooling wire corresponds to the case of a conductor in which the external electromotive force is suddenly removed.”

According to this conception, the heat conducting power of any substance corresponds to its electrical conducting power.

According to Stephan, in the case of a conductor of iron of 4 mm. in diameter, traversed by an alternating current of 250 alternations per second, the current density on the surface is about twenty-five times as great as that at its axis.

Where the conductor is of non-magnetic material, the difference in the current density is not so marked.

Rapidly intermittent currents produce a real increase in the resistance of the conductor, which must not be confused with the fact that the impedance is greater than the ohmic resistance, but rather as an actual increase in the rate at which energy is dissipated per unit of current.

Since current density is greatest at the outside portions of a conductor, and the central portions are nearly, if not entirely, deserted by the current, we may regard the conductor as having the ohmic resistance of a hollow cylinder of the same diameter as the conductor, with a correspondingly smaller area of cross-section, and therefore, of greater ohmic resistance per unit of length.

The condition of affairs in the case of a conductor in which a current of electricity is beginning to flow, is now very generally regarded somewhat as follows, viz.:

The current begins at the surface of the conductor, and more or less slowly soaks through towards the centre. If the current is constant, the current soon reaches the deepest layers; but, if it is rapidly intermittent, before it can soak very far into the conductor towards its axis, it is turned back towards the surface, and so becomes confined to layers which will be more and more superficial, as the rapidity of reversal increases.

Therefore, for convenience, we may regard a solid conductor, through which a rapidly intermittent current of electricity is flowing, as being practically converted into a hollow cylinder of the same diameter as the solid conductor, the area of cross-section of which hollow cylinder becomes smaller and smaller, as the rapidity of alternation is increased.

Another, and perhaps the more correct conception of the condition of affairs in a solid conductor traversed by a rapidly alternating current of electricity, has been pointed out by Maxwell, and afterwards by Heavyside, Rayleigh and Hughes. This conception is to regard the central portions of the conductor as possessing a counter electromotive force greater than the outer portions. The entire current flowing across any section of a conductor

may be regarded as made up of little *current streamlets*, parallel to one another.

The central streamlets, or filaments, from their mutual induction on one another, experience a greater resistance in reaching their full strength than the surface filaments do. Taken in this sense, we may state generally that the transmission of rapidly alternating currents through conductors depends on the inductance, rather than on the resistance; but for steady currents, it depends more on the resistance than on the inductance.

In periodic or oscillatory currents, as those produced by the discharge of a Leyden jar, or condenser, the surface streamlets have a current density far greater than the central streamlets.

The true or ohmic resistance of the circuit is a minimum when the current is uniformly distributed through all parts of the cross-section of the conductor, and the dissipation of energy through the generation of heat is less than for any other distribution.

The conception of a periodic current flowing through a conductor, starting from the surface and gradually soaking in towards the centre, regards the energy of an electric current—not as being pushed through the conductor, as water through a pipe, but as actually being absorbed at its surface, from the surrounding dielectric, or as being, so to speak, rained down on the conductor from the space outside of it.

Currents, Swelling — —In electro-therapeutics, currents that begin weak and are gradually made stronger and then weaker.

Currents, Swelling-Faradic — —A term employed in electro-therapeutics for faradic currents that are caused to gradually increase in strength and then to gradually decrease to zero strength.

Currents, Transient — —Currents that are but of momentary duration.

Currents, Undulatory — —Currents the strength and direction of whose flow gradually change.

The term undulatory currents is used in contradistinction to pulsatory currents, in which the strength changes suddenly. In actual practice, such currents differ from undulatory currents more in degree than in kind, since, when sent into a line, the effects of *retardation* tend to obliterate, to a greater or less extent, the sudden

differences in intensity on which their pulsatory character depends.

The currents produced in the coils of the Siemens magneto-electric key, in which the mechanical to-and-fro motion of the key sends electrical impulses into the line, are, in point of fact, undulatory in character, when they follow one another rapidly.

The currents in most dynamo-electric machines, the number of whose armature coils is comparatively great, are, so far as the variations in their intensity or strength are concerned, undulatory in character even when non-commuted.

The currents on all telephone lines that transmit articulate speech are undulatory. This is true, whether the transmitter employed merely varies the resistance by variations of pressure, or actually employs makes-and-breaks that rapidly follow one another.—(See *Current, Pulsatory, Current, Intermittent.*)

Curtain, Auroral — —A sheet of auroral light having the shape of a curtain. (See *Aurora Borealis.*)

Curve, Asymptote of — —A straight line which continually approaches a curved line, but meets or becomes tangent to such curved line only at an infinite distance.

In Fig. 186, the curve C D, continually approaches the asymptote $y z$, but never meets it.

It is at first difficult to understand how one line can continually approach another and yet never meet it. But it will be readily understood if it is remembered that in all cases of asymptotic approach each advance becomes smaller and smaller.

This mathematical conception is like a value which, although constantly reduced to one-half of its former value, is nevertheless never reduced to zero or no value.

Curve, Ballistic — —The curve actually described by a projectile thrown in any other than a vertical direction through the air.

The path of a projectile in a vacuum is a parabola—that is, the path A E B, Fig. 187. In air, the effects of fluid resistances cause the projectile to take the path A C D, called a *ballistic curve*.

The ballistic curve has a smaller vertical height than the parabola. The projectile also has a

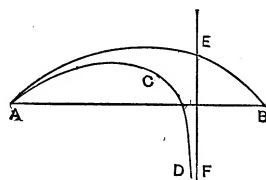

Fig. 187. Ballistic Curve.

smaller vertical range. Instead of reaching the point B, it continually approaches the perpendicular E F.

Curve, Characteristic — —A diagram in which a curve is employed to represent the ratio of certain varying values.

The electromotive force generated in the armature coils of a dynamo-electric machine, when the magnetic field is of a constant intensity, is theoretically proportional to the speed of rotation. In practice this is modified by a number of circumstances.

The relation existing between the speed and electromotive force may be graphically represented by referring the values to two straight lines, one horizontal and the other vertical, called respectively the *axes of abscissas and ordinates*. (See *Abscissas, Axis of.*) If, in a given case, the number of revolutions is marked off along the horizontal line from the point o, Fig. 188, in distances from o, proportional to the number of revolutions, and the corresponding electromotive forces are marked

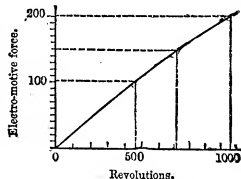

Fig. 188. Characteristic Curve.

off along the vertical line in distances from o, proportional to the electromotive forces, the points where these lines intersect will form the characteristic curve as shown in Fig. 188.

Curve, Characteristic, of Parallel Transformer — —A curve so drawn that its ordinate and abscissa at any point represent the secondary electromotive force and the secondary current of a multiple connected transformer, when the resistance of the secondary circuit has a certain definite value.

With a constant electromotive force in the pri-

primary circuit, *i. e.*, with the transformers in parallel, the characteristic curve is a straight line parallel to the axis of the current. This curve, as shown in Fig. 189, is practically a straight line. The parallel transformer will be practically self-regulating under a constant primary electromotive force.

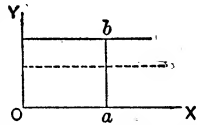

According to Forbes, if a transformer has its lamp in parallel with the secondary circuit, the efficiency of its lamps will decrease the efficiency of the transformer. The efficiency is therefore less for light loads than for heavy loads of parallel lamps up to a certain point.

Curve, Characteristic, of Series Transformer — —A curve so drawn that its ordinate and abscissa at any point represent the secondary electromotive force and secondary current of a series-connected transformer, when the resistance of the secondary current has a certain definite value.

Fig. 190 shows characteristic curve of a series

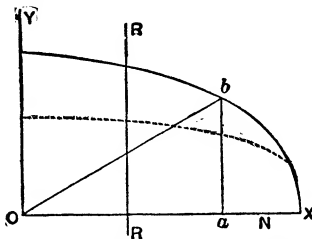

Fig. 190. Characteristic of Series Transformer.

transformer. $O a$, is drawn perpendicular to the line representing the secondary current, and $a b$, perpendicular to $O a$, represents the corresponding secondary electromotive force. The various positions of b , as different values are given to $O a$, produce the elliptic curve which is the characteristic curve of the series transformer.

“A series transformer,” says Fleming, “with a core sufficiently large to avoid saturation, can never be self-regulating if so used. It can only be made self-regulating with a non-saturated core, when working near the extremities of its characteristic, either with a small secondary current or a low electromotive force. Both of these conditions are uncommercial.”

Curve, Life, of Incandescent Lamp — —

—A curve in which the life of an electric lamp is represented by means of abscissas and ordinates proportional to the life in hours and the candle-power or the volts respectively.

Curve, Logarithmic — —A curve in which the rate of increase or decrease of the ordinate is proportional to the ordinate itself.

On the line $O X$, Fig. 191, mark off the time

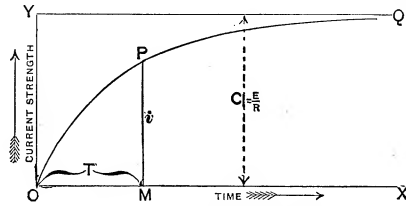

Fig. 191. Logarithmic Curve.

in lengths, reckoned from O . Represent the current strength by lines drawn vertically to the time-line. Let $O Y$, equal $C = \frac{E}{R}$.

Applying the electromotive force, the current grows in the wire as represented by the graphic curve.

According to Fleming, the growth of this current takes place according to the following law, viz.: “The current strength at any instant, added to the rate of growth of the current strength at that instant multiplied by the time-constant, is equal to the current which would exist if induction were zero,”

Curve, Permeability — —A curve representing the magnetic permeability of a magnetic substance.

There is a certain temperature for every paramagnetic substance, at which its permeability is no greater than that of air. This temperature for iron is reached at about 750 degrees C.; for nickel, at about 400 degrees C.

Curve, Simple-Harmonic — —The curve which results when a simple-harmonic motion in one line is compounded with a uniform motion in a straight line, at right angles thereto.

A harmonic curve is sometimes called a curve of sines, because the abscissas of the curve are proportional to the times, while the ordinates are proportional to the sines of the angles, which are themselves proportional to the times.

Curves, Isochasmen — —Curves drawn on the earth's surface between zones having equal frequency of auroral discharges.

The isochasmen curves are nearly at right angles to the magnetic meridian.

Curves, Magnetic — —Curved lines showing the direction of the lines of magnetic force in any field, formed by sprinkling iron filings on a sheet of paper or glass held in the field of a magnet, and gently tapping the support so as to permit the filings to properly arrange themselves. (See *Figures, Magnetic.*)

Cut-In, To — —To introduce an electro-receptive device into the circuit of an electric source by completing or making the circuit through it.

Cut-Off, Automatic Gas — —A device for automatically cutting out the battery from an electric gas-lighting circuit on the accidental grounding of the circuit.

Unless the battery is disconnected from the circuit on the establishing of a ground, the battery will polarize and soon become useless.

Cut-Out, A — —A device by means of which an electro-receptive device or loop may be thrown out of the circuit of an electric source.

In any system of light or power distribution, a cut out is generally placed outside a building into which a loop or branch of the main circuit runs, so as to permit that loop or branch to be readily disconnected therefrom. In the same way cut-out keys or switches are generally placed in the circuit of the loop and each electro-receptive device.

Cut-Out, Air-Space — —A modified form of paper cut-out, in which the disc of paper or mica is replaced by the resistance of an air-space.

Although the resistance of an air-space is so high as to be practically immeasurable, yet it is overcome or broken by a much lower difference of potential than an equal thickness of paper or mica. (See *Path, Alternative. Cut-Out, Film.*)

Cut-Out, Automatic — —Any device that will automatically cut-out, or remove, a translating device, or an electric source, from an electric circuit, whenever any predetermined effect is produced.

Cut-Out, Automatic, for Multiple-Connected Electro-Receptive Devices — — A device for automatically cutting an electro-receptive device, such as a lamp, out of the circuit of the leads.

Automatic cut-outs for incandescent lamps, when connected to the leads in multiple-arc, consist of strips of readily melted metal called *safety fuses*, which on the passage of an excessive current fuse, and thus automatically break the cir-

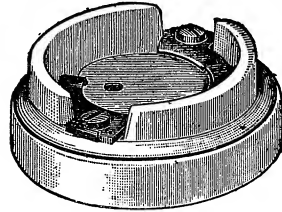
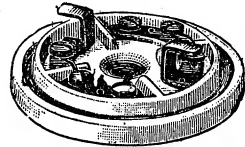

Fig. 192. Ceiling Cut-Out.

cuit in that particular branch. (See *Catch, Safety.*)

A form of ceiling cut-out, made of porcelain, is shown in Fig. 192, with the two halves separated

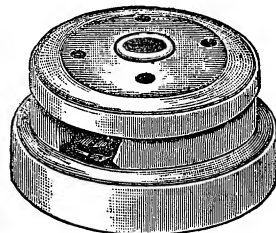

Fig. 193. Ceiling Cut-Out.

to show interior details, and in Fig. 193, with the two halves placed together.

Cut-Out, Automatic, for Series-Connected Electro-Receptive Devices — —A device whereby an electro-receptive device, such as an electric arc lamp, is, to all intents and purposes, automatically cut out, or removed from the circuit, by means of a shunt of low resistance, which permits the greater part of the current to flow past the lamp.

It will be observed that the lamp, though still in the circuit, is to all practical intents cut out from the same, since the proportion of the current that now passes through it is too small to operate it.

In most series arc lamps, cut-outs are operated by means of an electro-magnet placed in a shunt circuit of high resistance around the carbons. If the carbons fail to properly feed, the arc increases in length and consequently in resistance. More current passes through the shunt magnet, until finally, when a certain predetermined limit is reached, the armature of the electro-magnet is attracted to the magnet pole and mechanically completes the short circuit past the lamp.

In some automatic cut-outs the fusion of a readily fused wire, placed in a shunt circuit around the carbons, permits a spring to complete the short circuit.

The automatic cut-out prevents the accidental extinguishing of any single lamp in a series circuit from extinguishing the remaining lamps on that circuit.

Cut-Out, Automatic Time — —A device arranged so as to automatically cut out a translating device, or an electric source, from a circuit, at the end of a certain predetermined time.

Cut-Out, Duplex — —A cut-out so arranged that when one bar or strip is fused or melted by an abnormal current another can be immediately substituted for it.

Cut-Out, Film — —A cut-out in which a film, or sheet of paper or mica, is interposed between a line plate and an earth plate, which, when punctured by a spark, short circuits the instruments on the line.

Cut-Out, Main-Line — —An automatic cut-out placed on the main line. (See *Cut-Out, Automatic*.)

A form of main-line cut-out is shown in Fig.

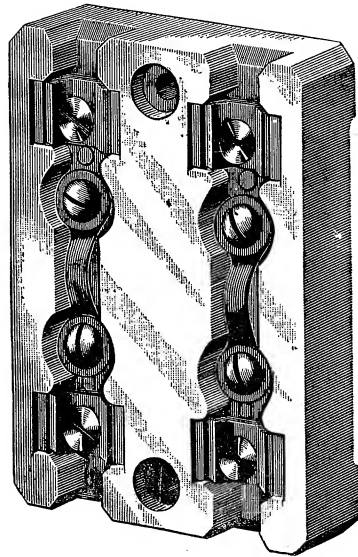

Fig. 194. Main-Line Cut-Out.

194. The fuses are shown as attached to the fuse-block.

Cut-Out, Paper — —A term sometimes employed instead of film cut-out. (See *Cut-Out, Film*.)

Cut-Out, Rosette — —A rosette for an electrolier, containing a cut-out. (See *Rosette*.)

Cut-Out, Spring-Jack — —A device similar in general construction to a spring-jack, but employed to cut out a circuit.

An insulated plug is thrust between spring contacts, thus breaking the circuit by forcing them apart.

Cut Out, To — —To remove an electro-receptive device from the circuit of an electric source by disconnecting or diverting the circuit from it.

Cutting Lines of Force.—(See *Force, Lines of Cutting*.)

Cycle.—A period of time within which a certain series of phenomena regularly recur, in the same order.

Cycle, Magnetic — —A single round of magnetic changes to which a magnetizable

substance, such as a piece of iron, is subjected when it is magnetized from zero to a certain maximum magnetization, then decreased to zero, reversed and carried to a negative maximum, and then decreased again to zero.

Cyclical Magnetic Variation.—(See *Variation, Cyclical Magnetic.*)

Cyclotrope.—A name proposed in place of transformer or converter. (See *Transformer.*)

Cylinder, Vortex — —A number of vortex stream-lines grouped parallel to one another about a straight line which forms the axis or core of the vortex.

Cylindrical Armature.—(See *Armature, Cylindrical.*)

Cylindrical Carbon Electrodes.—(See *Electrodes, Cylindrical Carbon.*)

Cylindrical Electro-Magnet.—(See *Magnet, Electro, Cylindrical.*)

Cylindrical Magnet.—(See *Magnet, Cylindrical.*)

Cylindrical Ring Armature.—(See *Armature, Cylindrical Ring.*)

Cymogene.—An extremely volatile liquid which is given off from crude coal oil during the early parts of its distillation.

The two liquids which are obtained from the condensation of the vapors given off during the first parts of the distillation of coal oil are called *cymogene*, and *rhigolene*. These liquids are employed on account of their extreme volatility for the artificial production of cold.

Rhigolene is employed by some for the treatment or flashing of the carbons used in incandescent lamps. (See *Carbons, Flashing Process for.*)

Cystoscopy, Electric — —A name given to Hitze's method of ocular examination of the human bladder by electric illumination.

D

Damped Magnetic Needle.—(See *Needle, Magnetic, Damped.*)

Damper.—A metallic cylinder provided in an induction coil so as to partially or completely surround the iron core, for the purpose of varying the intensity of the currents induced in the secondary.

The metallic cylinder acts as a screen or shield for the rapidly alternating currents traversing the field of the primary. (See *Screening, Magnetic.*) As the damper is pulled out, a greater length of the core is exposed to the induction.

Damper.—A term sometimes applied to a dash-pot or other similar apparatus provided for the purpose of preventing the too sudden movement of a lever or other part of a device. (See *Dash-Pot.*)

Some form of damper or dash-pot is used on most electric arc lamps, the upper carbon of which is fed by a direct fall.

The double use of this word is unfortunate.

Damping.—The act of stopping vibratory motion such as bringing a swinging mag-

netic needle quickly to rest, so as to determine the amount of its deflection, without waiting until it comes to rest after repeated swingings to and fro.

Damping devices are such as offer resistance to quick motion, or high velocities. Those generally employed in electrical apparatus are either *air* or *fluid friction*, obtained by placing vanes on the axis of rotation, or by checking the movements of the needle by means of the currents it sets up, during its motion, in the mass of any conducting metal placed near it. These currents, as Lenz has shown, always tend to produce motion in a direction opposed to that of the motion causing them. *Bell-shaped magnets* are especially suitable for this kind of damping. (See *Magnet, Bell Shaped.*)

The needle of a galvanometer is *dead-beat* when its *moment of inertia* is so small that its oscillations in an intense field are very quick, and the mirror, acting as a vane, causes the movements to die out very rapidly, and the needle therefore moves sharply over the scale from point to point and comes quickly to a *dead stop*. When the needle or swinging coil is heavy and moves in an intense

field, as in the Deprez-d'Arsonval galvanometer, the movements are dead-beat.

Damping by means of pieces of india rubber is often applied to telephone diaphragms to prevent their excessive or continued vibration.

Damping, Electric — — A term sometimes employed to express a decrease in the intensity of the electric oscillations produced in a conductor by electric resonance, under circumstances where higher overtones are set up in the conductor.

Daniell's Voltaic Cell.—(See *Cell, Voltaic, Daniell's*.)

Dark-Space, Crookes' — — (See *Space, Dark, Crookes'*.)

Dark-Space, Faraday's — — (See *Space, Dark, Faraday's*.)

Dash-Pot.—A mechanical device to prevent too sudden motion in a movable part of any apparatus.

The dash-pot of an automatic regulator, or of an arc-lamp, is provided to prevent too sudden movements of the collecting brushes on the commutator cylinder, or the too sudden fall of the upper carbon. Such devices consist essentially of a loose fitting piston that moves through air or glycerine.

Dash-pots are species of damping devices, and, like the damping arrangements on galvanometers or magnet needles, prevent a too free movement of the parts with which they are connected. (See *Damper. Damping*.)

Day, Normal Magnetic — — A day during which the value of the earth's magnetic elements does not vary greatly from their mean value. (See *Elements, Magnetic, of a Place*.)

Day of Disturbance, Magnetic — — A day during which the mean departure of the readings of a declinometer at any place, from the normal monthly value at that place, is once and a half the average.—(*Lloyd*.)

Dead-Beat.—Such a motion of a galvanometer needle in which the needle moves sharply over the scale from point to point and comes quickly to rest. (See *Damping*.)

Dead-Beat Discharge.—(See *Discharge, Dead-Beat*.)

Dead-Beat Galvanometer.—(See *Galvanometer, Dead-Beat*.)

Dead Dipping.—(See *Dipping, Dead*.)

Dead Earth.—(See *Earth, Dead or Total*.)

Dead Turns of Armature Wire, or Dead Wire.—(See *Turns, Dead, of Armature Wire*.)

Death, Electric — — Death resulting from the passage of an electric current through the human body.

The exact manner in which an electric current causes death is not known. When the current is sufficiently powerful, as in a lightning flash, or a powerful dynamo current, insensibility is practically instantaneous.

Death may be occasioned:

- (1.) As the direct result of physiological shock.
- (2.) From the action of the current on the respiratory centres.
- (3.) From the actual inability of the nerves or muscles, or both, to perform their functions.
- (4.) From an actual electrolytic decomposition of the blood or tissues of the body.
- (5.) From the polarization of those parts of the body through which the current passes.
- (6.) From an actual rupture of parts by a disruptive discharge.

The current required to cause death will depend on a variety of circumstances, among which are:

- (1.) The particular path the current takes through the body, with reference to the vital organs that may lie in this path.
- (2.) The freedom or absence of sudden variations of electromotive force.
- (3.) The time the current continues to pass through the body.

In some fatal cases, it is probably the *extra-current*, or the *induced-direct current on breaking*, that causes death, since, as is well known, its electromotive force may be many times greater than that of the original current.

A comparatively low-potential continuous-current, cannot, therefore, be properly regarded as entirely harmless, simply because its electromotive force is necessarily small. In the case of alternating currents the danger increases after a certain point with the number of alternations per second. When, however, the number of alternations per second reaches a given number, the danger decreases as the frequency of alternations

increases. This was conclusively shown by the independent investigations of Tatum and Tesla.

Decalescence.—A term proposed by Prof. Elihu Thomson for an absorption of sensible heat, which occurs at a certain time during the heating of a bar of steel.

Decalescence will thus be observed to be the reverse of recalescence, which is the phenomenon of the emission of sensible heat at a certain time during the cooling of a heated bar of steel. (See *Recalescence*.)

Deci (as a prefix).—The one-tenth.

Deci-Ampère.—One-tenth of an ampère.

Deci-Ampère Balance.—(See *Balance, Deci-Ampère*.)

Deci-Lux.—The one-tenth of a lux. (See *Lux*.)

Declination.—The variation of a magnetic needle from the true geographical north.

The magnetic declination is east or west. (See *Needle, Magnetic, Declination of*.)

Declination, Angle of — —The angle which measures the deviation of the magnetic needle to the east or west of the true geographical north.

The angle of variation of a magnetic needle.

In Fig. 195, if N S, represents the true north and south line, the angle of declination is N O A, and the sign of the variation is east, because the deviation of the needle is toward the east. (See *Needle, Magnetic, Declination of*.)

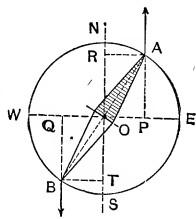

Fig. 195. Declination of Needle.

Declinometer.—A magnetic needle suitably arranged for the measurement of the value of the magnetic declination or variation at any place.

Decomposition.—In chemistry the separation of a molecule into its constituent atoms or groups of atoms. (See *Molecule, Atom*.)

Decomposition, Electric — —Chemical decomposition by means of an electric discharge or current.

This decomposition may result from an increase

of temperature produced by the electric discharge, or from the passage of the current. In the latter case it is more properly called *electrolytic decomposition*.

Decomposition, Electric, Crystallization by — —(See *Crystallization by Electrolytical Decomposition*.)

Decomposition, Electrolytic — —The separation of a molecule into its constituent atoms or groups of atoms by the action of the electric current.

These atoms or groups of atoms are either electro-positive or electro-negative in character. (See *Electrolysis, Anion, Kathion*.)

De-energize.—To deprive an electro-receptive device of its operating current.

De-energizing.—Depriving an electro-receptive device of its operating current.

Deep-Seated Eddy Currents.—(See *Currents, Eddy, Deep-Seated*.)

Deep-Water Submarine Cable.—(See *Cable, Submarine, Deep-Sea*.)

Deflagration, Electrical — —The fusion and volatilization of metallic substances by the electric current.

Deflagrator.—The name given to a voltaic battery, of small internal resistance, employed by Hare in the electric deflagration of metallic substances.

Deflection Method.—(See *Method, Deflection*.)

Deflection of Magnetic Needle.—(See *Needle, Magnetic, Deflection of*.)

Degeneration.—Such a degeneration of the muscular or cellular structure of any cell or organ that incapacitates it from performing its functions.

Degeneration of Energy.—(See *Energy, Degeneration of*.)

Degeneration, Partial, Reaction of — —That form of alteration to electric stimulation, in which the nerves show no abnormal reaction to electric stimulation, while the muscles, when directly stimulated by the constant current, exhibit the reaction of degeneration. (See *Degeneration, Reaction of*.)

Degeneration, Reaction of — —A qualitative and quantitative alteration of nerves and muscles to electric stimulation.

According to Landois and Stirling the following conditions characterize essentially the reaction of degeneration: "The excitability of the *muscles* is diminished or abolished for the faradic current, while it is increased for the galvanic current from the third to the fifty-eighth day; it again diminishes, however, with variations, from the seventy-second to eightieth day; the anodic closing contraction is stronger than the cathodic closing contraction." * * * "The diminution of the excitability of the *nerves* is similar for the galvanic and faradic currents."

Deka (as a prefix).—Ten times.

Deka-Ampère.—Ten ampères.

Deka-Ampère Balance.—(See *Balance, Deka-Ampère*.)

De la Rue's Standard Voltaic Cell.—(See *Cell, Voltaic, Standard, De la Rue's*.)

Deliquescence.—The solution of a crystalline solid arising from its absorption of vapor of water from the atmosphere.

Demagnetizable.—Capable of being deprived of magnetism.

Demagnetization.—A process, generally directly opposite to that for producing a magnet, by means of which the magnet may be deprived of its magnetism.

A magnet may be deprived of its magnetism, or be demagnetized—

(1.) By heating it to redness.

(2.) By touching to its poles magnet poles of the same name as its own.

(3.) By reversing the directions of the motions by which its magnetism was originally imparted, if magnetized by touch, by stroking it with a magnet in the opposite direction from that which would have to be given in order to produce the magnetization which is to be removed from it.

(4.) By exposing it in a helix to the influence of currents which will impart magnetism opposite to that which it originally possessed.

Avria claims that a smaller magnetizing force is required to demagnetize a needle than is required to magnetize it.

Demagnetization of Watches.—(See *Watches, Demagnetization of*.)

Demagnetize.—To deprive of magnetism.

Demagnetizing.—Depriving of magnetization.

Demarcation Current.—(See *Current, Demarcation*.)

Demarcation Surface.—(See *Surface, Demarcation*.)

Density, Electric — —The quantity of free electricity on any unit of area of surface.

The density is said to be positive or negative according as to whether the charge is positive or negative. (See *Charge, Density of. Plane, Magnetic Proof*.)

Density, Magnetic — —The strength of magnetism as measured by the number of lines of magnetic force that pass through a unit area of cross-section of the magnet, *i. e.*, a section taken at right angles to the lines of force. (See *Field, Magnetic*.)

Density of Charge.—(See *Charge, Density of*.)

Density of Current.—(See *Current Density*.)

Density of Field.—(See *Field, Density of*.)

Density, Surface — —A phrase used by Coulomb to mean the quantity of electricity per unit of area at any point on a surface. (See *Charge Density. Density, Electric*.)

Dental-Mallet, Electro-Magnetic — — A mallet for filling teeth, the blows of which are struck by means of electrically-driven mechanism.

Electro-magnetism was first employed for this purpose by Bonwill, of Philadelphia.

Dentiphone.—An audiphone. (See *Audiphone*.)

Depolarization.—The act of reducing or removing the polarization of a voltaic cell or battery. (See *Cell, Voltaic, Polarization of*.)

Depolarize.—To deprive of polarization.

Depolarizing.—Depriving of polarization.

Depolarizing Fluid.—(See *Fluid, Depolarizing*.)

Deposit, Black, Electro-Metallurgical — —A crystalline variety of electro-metallurgical deposit. (See *Deposit, Electro-Metallurgical*.)

Deposit, Crystalline, Electro-Metallurgical — —A non-adherent, non-coherent film of electrolytically deposited metal. (See *Deposit, Electro-Metallurgical*.)

Deposit, Electro-Metallurgical — — The deposit of metal obtained by any electro-metallurgical process.

To obtain a good metallic deposit the density of the current must be regulated according to the strength of the metallic solution employed.

Electro-metallurgical deposits are either—

(1.) *Reguline*, or flexible, adherent and strongly coherent metallic films, deposited when neither the current nor the solution is too strong; or,

(2.) *Crystalline*; or non-adherent and non-coherent deposits.

The crystalline deposit may either be of a *loose, sandy character*, which is thrown down when too feeble a current is used with too strong a metallic solution, or it may consist of a *black deposit*, which is thrown down when the current is too strong as compared with the strength of the solution. This latter character of deposit is sometimes technically called *burning*, and takes place most frequently at sharp corners and edges, where the current density is greatest. (See *Current Density*.)

Deposit, Electro-Metallurgical Nodular — —A coherent, irregular electro-metallurgical deposit which occurs whenever the current density falls below its normal value.

Deposit, Electro-Metallurgical, Reguline — —A flexible, adherent and strongly coherent film of metal electrolytically deposited. (See *Deposit, Electro-Metallurgical*.)

Deposit, Electro-Metallurgical, Sandy — —A non-coherent electro-metallurgical deposit which occurs whenever the current density exceeds its normal value.

Depositing Cell.—(See *Cell, Depositing*.)

Depositing Vat.—(See *Vat, Depositing*.)

Deposition, Electric — —The depositing of a substance, generally a metal, by the action of electrolysis. (See *Electrolysis*.)

The electric deposition of a metal on any conducting surface is sometimes called an electro-metallurgical deposition. (See *Metallurgy, Electro*.)

Deprez-d'Arsonval Galvanometer.—(See *Galvanometer, Deprez-d' Arsonval*.)

Derivative Circuit.—(See *Circuit, Derivative*.)

Derived Circuit.—(See *Circuit, Derived*.)

Derived Units.—(See *Units, Derived*.)

Destructive Distillation.—(See *Distillation, Destructive*.)

Detector Galvanometer.—(See *Galvanometer, Detector*.)

Detector, Ground — —In a system of incandescent lamp distribution, a device placed in the central station, for showing by the candle-power of a lamp the approximate location of a ground on the system.

Fig. 196, shows a form of ground-detector, in

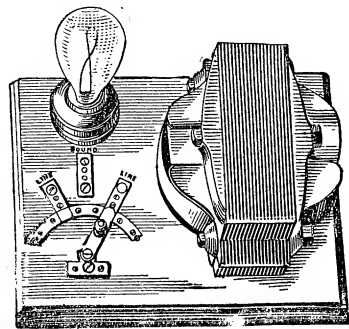

Fig. 196. *Ground-Detector*.

which a small transformer is placed on a board in connection with a lamp and a two-way switch. One terminal of the primary of the transformer is put to ground, while the other can be connected by means of the switch to one or the other of the two primary mains of the distribution circuit. Should an earth exist on either main, then when the testing transformer has its pole connected to the other main, the lamp in its secondary circuit will light up, providing the leak is of sufficient magnitude to permit a sufficiently great current to pass through the primary circuit.

Detorsion Bar.—(See *Bar, Detorsion*.)

Device, Electro-Receptive — —Various

devices placed in an electric circuit, and energized by the passage through them of the electric current.

A translating device.

The following are among the more important electro-receptive devices, viz.:

- (1.) Electro magnets.
- (2.) Electric motors.
- (3.) Electro-magnetic signal apparatus.
- (4.) Telegraphic or telephonic apparatus.
- (5.) An arc or incandescent lamp.
- (6.) An electric heater.
- (7.) A plating bath or voltmeter.
- (8.) An uncharged storage cell.
- (9.) A converter or transformer.

ELECTRO-RECEPTIVE DEVICES.

Motion Reproduced.

- (1.) Electric motor.
- (2.) Telpherage system.
- (3.) Telephone receiver.
- (4.) Telegraphic apparatus.
- (5.) Telephote receiver.

Radiant Energy Produced.

- (6.) Arc or incandescent electric lamp.
- (7.) Electric heater.
- (8.) Electric welder.
- (9.) Leyden jar or battery.

Chemical Decomposition Effected.

- (10.) Electrolytic bath.
- (11.) Uncharged storage battery.

Electro-Magnetism Produced.

- (12.) Electro-magnet.

Device, Feeding, of an Arc Lamp — —

A device for maintaining the carbon electrodes of an arc lamp at a constant distance apart during their consumption. (See *Lamp, Electric Arc.*)

Device, Magneto-Receptive — —Any device that is capable of being energized when placed in a magnetic field.

The term magneto-receptive device is used in contradistinction to electro-receptive device. (See *Device, Electro-Receptive.*)

Device or Arrangement, Electromotive — —A term sometimes employed instead of an electric source. (See *Source, Electric, Arrangement or Device, Electromotive.*)

Device, Safety, for Arc Lamps, or Series Circuits — —Any mechanism which automatically provides a path for the current around a lamp, or other faulty electro-receptive device in a series circuit, and thus prevents the opening of the entire circuit on the failure of such device to operate. (See *Lamp, Electric Arc.*)

Device, Safety, for Multiple Circuits — —A wire, bar, plate or strip of readily fusible metal, capable of conducting, without fusing, the current ordinarily employed on the circuit, but which fuses and thus breaks the circuit on the passage of an abnormally great current.

The terms *safety-catch*, *safety-plug*, *safety-strip* and *safety-fuse* are also used for this *safety device*. (See *Fuse, Safety.*)

Device, Translating — —A term embracing electro-receptive and magneto-receptive devices. (See *Device, Electro-Receptive.*)

Translating devices are placed in an electric circuit, and when traversed by the current effect a change, or translation in the form of the electric energy whereby useful work is accomplished.

Translating devices depend for their operation on the luminous, heating, magnetic, or chemical effects of the current.

Devices, Electro-Receptive, Multiple-Connected — —A connection of electro-receptive devices, in which the positive poles of a number of separate devices are all connected with a single positive lead or conductor, and the negative poles all connected with a single negative lead or conductor.

The multiple-arc-connection of electro-receptive devices is suitable for *constant potential circuits*, or those in which the electromotive force is maintained approximately constant. In such circuits the energy absorbed by each device will increase as its resistance decreases, since the energy absorbed is proportional to the current passing. (See *Circuits, Varieties of.*)

Multiple-arc-connected electro-receptive devices are employed in incandescent lamp distribution. Each device added reduces the resistance of the entire circuit.

Devices, Electro-Receptive, Multiple-Arc-Connected — —A term used in place of multiple-connected electro-receptive devices. (See *Devices, Electro-Receptive, Multiple-Connected.*)

Devices, Electro-Receptive, Multiple-Series-Connected — —A connection of electro-receptive devices in which a number of separate electro-receptive devices are connected in groups in series, and each of these separate groups afterwards connected in multiple-arc.

The multiple-series connection permits electro-receptive devices to be placed on mains whose electromotive force would be too high to permit a single service to be connected directly to them. It is of great value in the distribution of incandescent lamps by constant currents, since by permitting a higher electromotive force to be employed on the main conductors, it reduces the dimensions of the conductors required for the economical distribution of the current. (See *Circuits, Varieties of.*)

Devices, Electro-Receptive, Series-Connected — —The connection of electro-receptive devices in which the devices are placed consecutively in the circuit, so that the current passes successively through all of them from the first to the last.

The series-connection of electro-receptive devices is suited to *constant-current circuits*. The work done in the device is developed by the fall of potential in each device. This kind of connection is used in most systems of arc light and telegraphic lines. (See *Circuits, Varieties of.*)

Devices, Electro-Receptive, Series-Multiple-Connected — —A connection of electro-receptive devices in which a number of separate electro-receptive devices are joined in separate multiple groups, and each of these groups subsequently connected with one another in series.

The effect of series-multiple connections is to split up the current into a number of separate currents of smaller strength, but of the same electromotive force. It is applicable to such cases as the combination of arc and incandescent lamps in the same circuit. (See *Circuits, Varieties of.*)

Devices, Translating, Multiple-Con-

nected — —A term sometimes used for multiple-connected electro-receptive devices. (See *Devices, Electro-Receptive, Multiple-Connected.*)

Devices, Translating, Multiple-Arc-Connected — —A term used in place of multiple-connected electro-receptive devices. (See *Devices, Electro-Receptive, Multiple-Connected.*)

Devices, Translating, Multiple-Series-Connected — —A term sometimes used instead of multiple-series-connected electro-receptive devices. (See *Devices, Electro-Receptive, Multiple-Series-Connected.*)

Devices, Translating, Series-Connected — —A term sometimes used for series-connected electro-receptive devices. (See *Devices, Electro-Receptive, Series-Connected.*)

Devices, Translating, Series-Multiple-Connected — —A term sometimes used for series-multiple-connected electro-receptive devices. (See *Devices, Electro-Receptive, Series-Multiple-Connected.*)

Dextrorsal Helix.—(See *Helix, Dextrorsal.*)

Dextrorsal Solenoid.—(See *Solenoid, Dextrorsal.*)

Diacritical Current.—(See *Current, Diacritical.*)

Diacritical Number.—(See *Number, Diacritical.*)

Diacritical Point of Magnetic Saturation.—(See *Saturation, Magnetic, Diacritical Point of.*)

Diagnosis, Electro.—Diagnosis by means of the exaggeration or diminution of the reaction of the excitable tissues of the body when subjected to the varying influences of electric currents.

The electric current has also been applied in order to distinguish between forms of paralysis, and as a final test of death.

Diagnostic, Electro — —Pertaining to electro-diagnosis. (See *Diagnosis, Electro.*)

Diagometer, Rousseau's — —An apparatus in which an attempt is made to

determine the chemical composition and consequent purity of certain substances by their electrical conducting powers.

The arrangement of the apparatus is shown in Fig 197. A dry pile, A, has its negative, or —

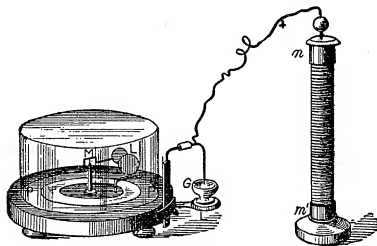

Fig. 197. Rousseau's Diagonometer.

terminal, m', grounded. Its positive, or + terminal is connected to a delicately supported, and slightly magnetized needle, M, terminated by a conducting plate, L. Opposite L, and at the same height, is a fixed plate of slightly larger size. The needle M, when at rest in the plane of the magnetic meridian, is in contact at L, with the fixed plate. If, therefore, the upper plate of the pile is connected with the needle M, both plates are similarly charged and repulsion takes place, the needle coming to rest at a certain distance from the fixed plate.

The substance whose purity is to be determined is placed in the cup G, which is connected, through L, with the fixed plate. A branch wire from the + terminal of the pile is then dipped into the substance in G, and its purity determined from the length of time required for the two plates at L, to be discharged through the material in G.

It is claimed that the instrument will detect the difference between pure coffee and chicory. Its practical application, however, is very doubtful.

Diagram, Thermo-Electric — — A diagram in which the thermo-electric power between different metals is designated for different temperatures.

The differences of potential, produced by the mere contact of two metals, varies, not only with the kind of metals, and the physical state of each metal, but also with their temperature. This difference of potential, maintained in consequence of the difference of temperature between the junctions of a *thermo-electric couple*, is approximately proportional to the differences of temperature of these junctions, if these differences are not great, and is equal to the product of such

differences of temperature and a number dependent on the metals in the couple. This number is called the *thermo-electric power*. (See *Couple, Thermo-Electric. Thermo-Electric Power.*)

In Fig. 198 (after Tait), the thermo-electric

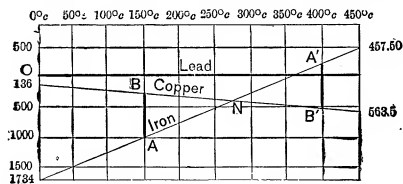

Fig. 198. Thermo-Electric Diagram.

power is shown between lead and iron, and lead and copper. The numbers at the top of the table represent degrees of the centigrade thermometer. Those at the sides represent the differences of potential in *micro-volts*.

The thermo-electric power of the copper-iron couple decreases from the freezing point of water, 0 degrees C., to a temperature of 274.5 degrees C., when it becomes zero. Beyond that temperature the thermo-electric power increases, but in the opposite direction. The point at which this occurs is called the *neutral point*.

Dial Telegraph.—(See *Telegraphy, Dial.*)

Dialysis.—The act of separating a mixture of crystalloids and colloids by diffusion through a membrane.

If, for example, the contents of a stomach, in a case of suspected poisoning, be placed in a vessel, the bottom of which is formed of a sheet of parchment paper and floated in water, the crystalloid or substances capable of crystallizing, will pass into the water and the colloid, an uncrystallized jelly-like substance, will remain in the vessel. This process has been used to detect the presence of poison in the stomach in post-mortem cases.

Diamagnetic.—The property possessed by substances like bismuth, phosphorus, antimony, zinc and numerous others, of being apparently repelled when placed between the poles of powerful magnets.

When diamagnetic substances in the form of rods or bars are placed, as in Fig. 199, between the poles of a powerful electro-magnet, they place themselves at right angles to the poles, or are apparently repelled.

Paramagnetic substances like iron or steel, on the contrary, come to rest under similar circum-

stances in a straight line joining the poles, at right angles to the position shown in Fig. 199.

Paramagnetic substances are sometimes called *ferro-magnetic*, or substances magnetic after the manner of iron. This word is unnecessary and ill-advised. The term *sidero-magnetic*, which has also been proposed in place of paramagnetic, is also unnecessary.

Paramagnetic substances appear to concentrate the lines of magnetic force on them; that is, their magnetic resistance is smaller than that of the air or other medium in which the magnet is placed. They, therefore, come to rest with their greatest dimensions in the direction of the lines of magnetic force.

Diamagnetic substances appear to have a greater magnetic resistance than that of the air around them. They, therefore, come to rest with their least dimensions in the direction of the lines of magnetic force.

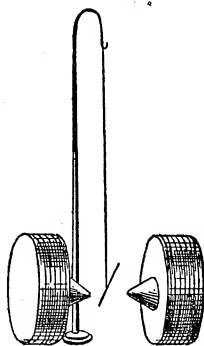

Fig. 199 Effect of Paramagnetism.

The difference between paramagnetic and diamagnetic substances is generally believed to be due to the varying resistance these substances thus offer to lines of magnetic force as compared with that offered by air or by a vacuum.

Tyndall comes to the conclusion as the result of extended experimentation: "That the diamagnetic force is a polar force, the polarity of diamagnetic bodies being opposed to that of paramagnetic ones under the same conditions of excitement."

This view, however, is not generally accepted by scientists.

Diamagnetism is also possessed by certain liquid and gaseous substances.

Diamagnetic Polarity.—(See *Polarity, Diamagnetic.*)

Diamagnetically.—In a diamagnetic manner.

Diamagnetism.—A term applied to the magnetism of diamagnetic bodies. (See *Diamagnetic.*)

Diamagnetism, Weber's Theory of —
—A theory to account for the phenomena of diamagnetism.

Weber's theory of diamagnetism, like Ampère's theory of magnetism, supposes that magnetic substances consist of originally magnetized molecules or atoms, and that the act of magnetization consists of polarizing these atoms or molecules, or turning them in one and the same direction. That the original condition of the molecules or atoms is probably due to the passage of electricity, which continually circulates through their mass, the atoms being supposed to possess perfect conductivity.

Suppose the substance through whose molecules or atoms these currents are flowing be immersed in a magnetic field. All of the molecules or atoms which can turn so as to look along lines of force in the right direction will have the current flowing in them thereby weakened so long as they remain in the field. When drawn out of it, however, these currents will regain their normal strength.

Suppose now the case of a substance, in which the currents are normal but weak, immersed in a strong magnetic field. There may thereby be effected a complete reversal of the direction of these currents, and others may be produced which flow in the opposite direction, and which will continue so to flow as long as the substance remains in the field. Such currents would then be sufficient to explain the phenomena of diamagnetic action.

An electric current produced in a circuit near which a momentary current of electricity is suddenly brought has now the opposite direction to that which produces it, and this momentary current would tend to produce repulsion. When,

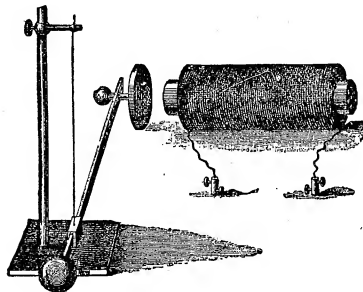

Fig. 200. Weber's Theory of Diamagnetism.

too, the circuit is drawn out of the neighborhood in which another current is flowing, another mo-

mentary current is produced in the same direction. This produces attraction.

Now, regarding the same phenomena from the standpoint of lines of magnetic force, when a conductor through which a current is passing is placed in a magnetic field, any increase in the number of lines of magnetic force passing through it tends to move the conductor out of the magnetic field, while any decrease in the number of lines of force tends to move the conductor into the field. To experimentally show the attractions and repulsions produced by magnetization or demagnetization, the following apparatus may be employed:

A stout disc of copper, Fig. 200, is supported on a horizontal arm in the position shown in front of the pole of a powerful electro-magnet. When the current is sent through the electro-magnet the disc of copper is repelled from the magnetic pole. When the magnetism is being destroyed by the opening of the circuit and by the weakening of the current, the copper disc is attracted.

Diamagnetometer.—An apparatus designed for studying diamagnetism. (See *Diamagnetism*.)

The apparatus for the study of paramagnetism generally receives simply the name of magnetometer.

Diamagnets. — Diamagnetic substances subjected to magnetic induction and formerly called diamagnets in contradistinction to ordinary magnets.

Diamagnets are supposed by some to possess a polarity the same as that of the inducing pole, instead of the opposite polarity, as in paramagnetic substances. (See *Diamagnetism*.)

Diaphragm.—A sheet of some solid substance, generally elastic in character and circular in shape, securely fixed at its edges and capable of being set into vibration.

The *receiving diaphragm* of a telephone is generally a thin plate or disc of iron, fixed at its edges, placed near a magnet pole and set into vibration by variations in the magnetic strength of the pole, due to variations in the current that is passed over the line.

The *transmitting diaphragm* of the telephone or of a phonograph, consists of a plate fixed at its edges and set into vibration by the sound waves striking it.

Diaphragm.—A term sometimes employed for a plate form of porous cell.

Diaphragm Currents.—(See *Currents, Diaphragm. Cell, Porous*.)

Diaphragm of Voltaic Cell.—A term sometimes used for the porous cell of a double fluid voltaic cell when in the form of a plate.

Dice-Box Insulator.—(See *Insulator, Dice-Box*.)

Dielectric.—A substance which permits induction to take place through its mass.

This word is sometimes, but improperly, written Di-Electric.

The substance which separates the opposite coatings of a condenser is called the dielectric. All dielectrics are non-conductors.

All non-conductors or insulators are dielectrics, but their dielectric power is not exactly proportional to their non-conducting power.

Substances differ greatly in the degree or extent to which they permit induction to take place through or across them. Thus, a certain amount of inductive action takes place between the insulated metal plates of a condenser across the layer of air between them.

A dielectric may be regarded as pervious to rapidly reversed periodic currents, but opaque to continuous currents. There is, however, some conduction of continuous currents.

According to Swinburne, there are three species of conduction that may take place in dielectrics, all of which produce a heating of the dielectric, viz.:

(1.) *Metallic Conduction, i. e.*, such a conduction as takes place in a metal. This kind of conduction arises from the presence of metallic particles embedded in the dielectric.

(2.) *Disruptive Conduction*, or a momentary current accompanying a disruptive discharge.

(3.) *Electrolytic Conduction*, or that kind of conduction which accompanies the electrolysis of a conductor. This kind of conduction may take place in some kinds of glass.

Faraday regarded the dielectric as the true seat of electric phenomena. Conducting substances he considered as mere breaks in the continuity of the dielectric. This is the view now generally held.

Dielectric Capacity.—(See *Capacity, Dielectric*.)

Dielectric Constant.—(See *Constant, Dielectric.*)

Dielectric Density of a Gas.—(See *Gas, Dielectric Density of.*)

Dielectric, Polarization of — —A molecular strain produced in the dielectric of a Leyden jar or other condenser, by the attraction of the electric charges on its opposite faces, or by the electrostatic stress. (See *Strain, Dielectric.*)

A term formerly employed in place of electric displacement.

Faraday, in his study of the action of induction, in denying the possibility of action at a distance, thought that the dielectric through which induction takes place was polarized, and that in this way the induction was transmitted across the intervening space between the inducing and the induced body, by the action of the contiguous particles of the dielectric.

The polarization of the glass of a Leyden jar, and the accompanying strain, are seen by the frequent piercing of the glass, and by the residual charge of the jar. (See *Charge, Residual.*)

Dielectric Resistance.—(See *Resistance, Dielectric.*)

Dielectric Strain.—(See *Strain, Dielectric.*)

Dielectric Strength of a Gas.—(See *Gas, Dielectric Strength of.*)

Dielectric Stress.—(See *Stress, Dielectric.*)

Difference of Potential.—(See *Potential, Difference of.*)

Differential Electric Bell.—(See *Bell, Differential Electric.*)

Differential Galvanometer.—(See *Galvanometer, Differential.*)

Differential Inductometer.—(See *Inductometer, Differential.*)

Differential Method of Duplex Telegraphy.—(See *Telegraphy, Duplex, Differential Method of.*)

Differential Relay.—(See *Relay, Differential.*)

Differential Thermo-Pile.—(See *Pile, Thermo, Differential.*)

Differential Voltmeter.—(See *Voltmeter, Siemens' Differential.*)

Differentially Wound Motor.—(See *Motor, Differentially Wound.*)

Diffusion, Anodal — —A term applied to the introduction of any drug into the human body by electricity.

The cataphoretic introduction of drugs into the body. (See *Cataphoresis.*)

A sponge or other similar electrode, saturated with a solution of the drug, is connected with the anode of a source and placed over the part to be treated and its kathode connected to another part of the body in a nearly direct line with the anode and the current passed.

Diffusion Creep.—(See *Creep, Diffusion.*)

Diffusion of Electric Current.—(See *Current, Diffusion of.*)

Diffusion of Lines of Force.—(See *Force, Lines of Diffusion of.*)

Dimensions of Acceleration.—(See *Acceleration, Dimensions of.*)

Dimensions of Units—(See *Units, Dimensions of.*)

Diminished Electric Irritability.—(See *Irritability, Electric, Diminished.*)

Dimmer — —A choking coil, employed in a system of distribution by converters or transformers, for regulating the potential of the feeders.

The dimmer consists essentially of a choking coil wound around a laminated ring of soft iron,

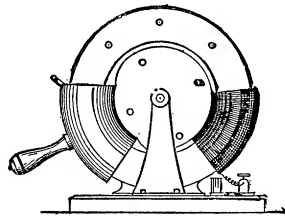

Fig. 201. Reaction Coil Dimmer.

and provided with an envelope of heavy copper. The copper ring, by its position as regards the choking coil, adjusts or regulates the self-induction of the coil, and consequently regulates the potential of the feeders. The dimmer is used in theatres or similar situations to turn the lights up or down.

The reaction coil or dimmer is shown in Fig. 201. The choking coil is wound on a ring of iron. The copper sheath is furnished with a handle to permit its position to be readily changed with respect to the coil of insulated wire. A laminated iron drum is supported on bearings inside the ring. When the sheath is over the coil, the coil offers but a small resistance to the passage of the current. When away from it the self-induction of the coil is increased.

Dioptre.—A unit of refracting power.

A lens of one dioptre has a focal length of one metre. One of two dioptries has a focal length of 50 centimetres; one of four dioptries 25 centimetres. This is also spelled *dioptry*.

Dioptric.—Relating to dioptries.

Dioptries.—The science which treats of the refraction of light.

Dioptry.—A word sometimes used for *dioptre*. (See *Dioptre*.)

Dip, Magnetic — —The deviation of a magnetic needle from a true horizontal position.

The inclination of the magnetic needle towards the earth.

The magnetic needle shown in Fig. 202, though

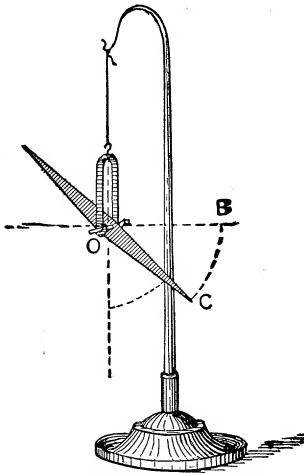

Fig. 202. Angle of Dip.

supported at its centre of gravity, will not retain a horizontal position in all places on the earth's surface.

In the northern hemisphere its *north-seeking* end will dip or incline at an angle B O C, called the *angle of dip*. In the southern hemisphere its south-seeking end will dip.

The cause of the dip is the unequal distance of the magnetic poles of the earth from the poles of the needle.

The *magnetic equator* is a circle passing around the earth midway (in intensity) between the earth's magnetic poles. There is no dip at the magnetic equator. At either magnetic pole the angle of dip is 90 degrees.

Dip, or Inclination, Angle of — — The angle which a magnetic needle, free to move in both a vertical and a horizontal plane, makes with a horizontal line passing through its point of support.

The angle of dip of a magnetic needle. (See *Inclination, Angle of*.)

Diplex Telegraphy.—(See *Telegraphy, Diplex*.)

Dipping.—An electro-metallurgical process whereby a deposit or thin coating of metal is obtained on the surface of another metal by dipping it in a readily decomposable metallic salt.

Cleansing surfaces for electro-plating processes by immersing them in various acid liquors.

Dipping, Bright — —Dipping in acid liquors for the purpose of obtaining a bright electro-metallurgical coating.

Dipping Circle.—(See *Circle, Dipping*.)

Dipping, Dead — —Dipping in acid liquors for the purpose of obtaining a dead or unpolished surface on an electro-metallurgical coating.

Dipping, Electro-Metallurgical — — A process for obtaining an electro-metallurgical deposit on a metallic surface by dipping it in a solution of a readily decomposable metallic salt.

A bright, polished iron surface, when simply dipped into a solution of copper-sulphate, receives a coating of metallic copper from the electrolytic action thus set up.

This process is known technically as *dipping*. The term dipping is also used in electro-metallurgy to indicate the process of cleaning the

articles, that are to be electro-plated, by dipping them in various acid or alkaline baths.

Direct Current.—(See *Current, Direct.*)

Direct-Current Electric Motor.—(See *Motor, Electric, Direct-Current.*)

Direct Electromotive Force.—(See *Force, Electromotive, Direct.*)

Direct Excitation.—(See *Excitation, Direct.*)

Direct-Induced Current.—(See *Current, Direct-Induced.*)

Direct, or Break-Induced Current —
—(See *Current, Direct. Current, Break-Induced.*)

Direct Working.—(See *Working, Direct.*)

Direction, Negative, of Electrical Convection of Heat — —A direction in which heat is transmitted through an unequally heated conductor by electric convection, during the passage of electricity through the conductor, opposite that of the current. (See *Heat, Electric Convection of.*)

Direction of Lines of Force.—(See *Force, Lines of, Direction of.*)

Direction, Positive, of Electrical Convection of Heat — —A direction in which heat is transmitted through an unequally heated conductor by electric convection, during the passage of electricity through the conductor, the same as that of the current. (See *Heat, Electric Convection of.*)

Direction, Positive, Round a Circuit — —In a plane circuit looked at from one side, a direction opposite to that of the hands of a clock.

This is a convention which has been made in order to conveniently connect the direction of the electromotive force produced by induction, with the direction of the induction.

Direction, Positive, Through a Circuit — —In a plane circuit, looked at from one side, a direction through the circuit away from the observer.

Directive Tendency of Magnetic Needle.
—(See *Needle, Magnetic, Directive Tendency of.*)

Disc, Arago's — —A disc of copper

or other non-magnetic metallic substance, which, when rapidly rotated under a magnetic needle, supported independently of the disc, causes the needle to be deflected in the direction of rotation, and, when the velocity of the disc is sufficiently great, to rotate with it.

Such disc is shown in Fig. 203 at b. The move-

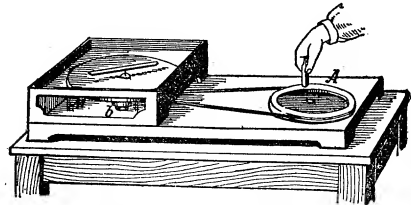

Fig. 203. Arago's Disc.

ment of the needle is due to electric currents, induced by the disc moving through the field of the needle so as to cut its lines of magnetic force. To obtain the best results the disc must move very rapidly, and should be near the needle. Moreover, the needle should be powerful.

This effect was discovered by Arago, in 1824. Since a magnetic needle moving over a metallic plate produces electric currents in a direction which tends to stop the motion of the needle, a damping of the motion of a magnetic needle is sometimes effected by causing it to move near a metal plate. The induced currents, which the needle produces in the plate by its motion over it, tend to retard the motion of the needle. (See *Damping. Law, Lenz's.*)

Disc Armature.—(See *Armature, Disc.*)

Disc, Faraday's — —A metallic disc movable in a magnetic field on an axis parallel to the direction of the field.

Such a disc is shown in Fig. 204, and moves,

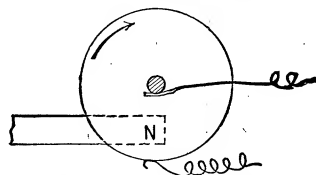

Fig. 204. Faraday's Disc.

as will be seen, so as to cut the lines of magnetic force at right angles.

The difference of potential generated by the motion of such a disc may be caused to produce a current, by providing a circuit which is completed through the portion of the disc that at any

moment of its rotation is situated between spring contacts resting on the axis of rotation and the circumference of the disc, respectively.

In *Barlow's* or *Sturgeon's wheel*, Fig. 205, the

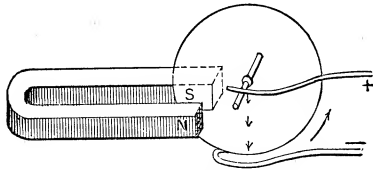

Fig. 205. *Barlow's Wheel.*

wheel itself rotates in the direction shown, when a current is sent through it in a direction indicated by the arrows.

Discharge.—The equalization of the difference of potential between the terminals of a condenser or source, on their connection by a conductor.

The removal of a charge from the surface of any charged conductor by connecting it with the earth, or another conductor.

The removal of a charge by means of a stream of electrified air particles.

The discharge of an insulated conductor, a cloud, a condenser, or a Leyden battery, is *oscillatory*. The oscillatory currents continue but for a short time. The discharge is therefore often spoken of as producing *momentary* currents.

The discharge of a voltaic battery, or a storage battery, is nearly continuous, and furnishes a current which is practically continuous, as distinguished from the momentary currents produced by the discharge of a condenser.

A discharge may be *alternating, brush, brush and spray, conductive, convective, dead-beat, disruptive, flaming, glow, lateral, oscillatory, periodic, stratified, streaming, impulsive and periodic*.

Discharge, Alternating — —An electric discharge which changes its direction at regular intervals of time.

A periodic discharge.

Discharge, Brush — —A faintly luminous discharge that occurs from a pointed positive conductor.

The brush discharge is a species of convective discharge. In it, the streams of electrified air particles assume the characteristic brush shape. (See *Discharge, Convective*.)

Discharge, Brush-and-Spray — —A form of streaming discharge obtained by increasing the frequency of the alternations of a high potential current which assumes the appearance of a spray of silver-white sparks, or a bunch of thin silvery threads around a powerful brush.

Some idea of the brush-and-spray discharge may be obtained from Fig. 206, taken from

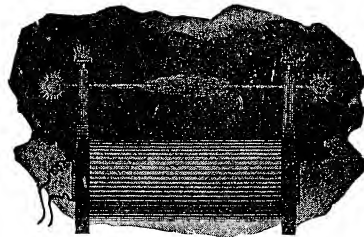

Fig. 206. *Brush-and-Spray Discharge (Tesla).*

Tesla, who has carefully studied these phenomena.

The brush-and-spray discharge is best obtained, according to Tesla, by bringing the terminals of a source of rapidly alternating electrostatic currents of high potential somewhat nearer together, when the streaming discharge has been obtained, and preferably increasing the frequency of the alternations.

The brush-and-spray discharge, when powerful, closely resembles a gas flame from gas escaping under great pressure. Says Tesla: "But they do not only *resemble*, they *are* veritable flames, for they are hot. Certainly they are not as hot as a gas-burner, *but they would be so if the frequency and the potential would be sufficiently high.*"

The brush-and-spray discharge, at higher frequencies, passes into a form of discharge for which Tesla has proposed no particular name. He describes this form, in a publication of a lecture before the American Institute of Electrical Engineers, as follows, viz.:

"If the frequency is still more increased, then the coil refuses to give any spark unless at comparatively small distances, and the fifth typical form of discharge may be observed (Fig. 207). The tendency to stream out and dissipate is then so great that when the brush is produced at one terminal no sparking occurs, even if, as I have repeatedly tried, the hand, or any conducting object, is held within the stream; and, what is more

singular, the luminous stream is not at all easily deflected by the approach of a conducting body.

“At this stage the streams seemingly pass with the greatest freedom through considerable thicknesses of insulators, and it is particularly interesting to study their behavior. For this purpose it is convenient to connect to the terminals of the coil two metallic spheres, which may be placed at any desired distance (Fig. 208). Spheres are pref-

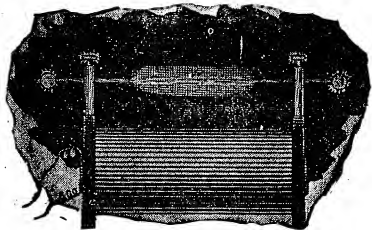

Fig. 207. Fifth Typical Form of Discharge (Tesla).

erable to plates, as the discharge can be better observed. By inserting dielectric bodies between the spheres, beautiful discharge phenomena may be observed. If the spheres be quite close and a spark be playing between them, by interposing a thin plate of ebonite between the spheres the spark instantly ceases and the discharge spreads into an intensely luminous circle several inches in diameter, provided the spheres are sufficiently large. The passage of the stream heats, and, after a while, softens the rubber so much that two

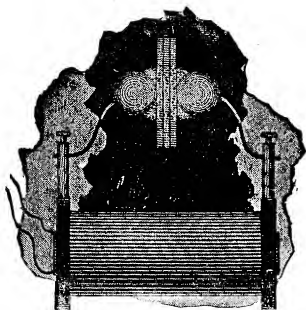

Fig. 208. Luminous Discharge with Interposed Insulators.

plates may be made to stick together in this manner. If the spheres are so far apart that no spark occurs, even if they are far beyond the striking distance, by inserting a thick plate of glass the discharge is instantly induced to pass from the spheres to the glass in the form of luminous streams. It appears almost as though these

streams pass *through* the dielectric. In reality this is not the case, as the streams are due to the molecules of the air which are violently agitated in the space between the oppositely charged surfaces of the spheres.

“When no dielectric other than air is present, the bombardment goes on, but is too weak to be visible; by inserting a dielectric the inductive effect is much increased, and besides, the projected air molecules find an obstacle and the bombardment becomes so intense that the streams become luminous. If by any mechanical means we could effect such a violent agitation of the molecules we could produce the same phenomenon. A jet of air escaping through a small hole under enormous pressure and striking against an insulating substance, such as glass, may be luminous in the dark, and it might be possible to produce phosphorescence of the glass or other insulators in this manner.

“The greater the specific inductive capacity of the interposed dielectric, the more powerful the effect produced. Owing to this the streams show themselves with excessively high potentials even if the glass be as much as one and one-half to two inches thick. But besides the heating due to bombardment, some heating goes on undoubtedly in the dielectric, being apparently greater in glass than in ebonite. I attribute this to the greater specific inductive capacity of the glass in consequence of which, with the same potential difference, a greater amount of energy is taken up in it than in rubber. It is like connecting to a battery a copper and a brass wire of the same dimensions. The copper wire, though a more perfect conductor, would heat more by reason of its taking more current. Thus what is otherwise considered a virtue of the glass is here a defect. Glass usually gives way much quicker than ebonite; when it is heated to a certain degree the discharge suddenly breaks through at one point, assuming then the ordinary form of an arc.”

Discharge, Conductive — — A discharge effected by leading the charge off through a conductor placed in contact with the charged body.

Discharge, Convective — — A discharge which occurs from the points on the surface of a highly charged conductor, through the repulsion by the conductor of air particles that in this manner carry off minute charges.

A convective discharge, though often attended by a feeble sound, is sometimes called a *silent discharge*, in order to distinguish it from the *noisy, disruptive discharge*, which is attended by a sharp snap, or when considerable, by a loud report.

A convective discharge is also called a *glow* or *brush discharge*. The latter is best seen at the small button at the end of the *prime* or *positive conductor* of a frictional electric machine.

The *positive discharge* from a point or small rounded conductor is always *brush-shaped*; the *negative discharge* is always *star shaped*.

In rarefied gases, the discharge is convective in character and produces various luminous effects of great beauty, the color of which depends on the kind of gas, and the size, shape and material of the electrodes, and on the degree of the vacuum. Thus in the rarefied space of the vessel shown in Fig. 209, the discharge becomes an ovoidal mass of light, sometimes called the *Philosopher's Egg*.

When the discharges in rarefied gases follow one another very rapidly, alternations of light and darkness, or *stratifications*, or *striae* are produced.

The breadth of the dark bands increases as the vacuum becomes higher. The light portions start at the positive electrode, and are hotter than the dark portions.

The effects of luminous convective discharges are best seen in exhausted glass tubes, called *Geissler tubes*, containing residual atmospheres of various gases. (See *Tubes, Geissler*.)

Discharge, Dead-Beat — — A non-oscillatory discharge. (See *Discharge, Oscillatory*.)

Discharge, Disruptive — — A sudden, and more or less complete, discharge that takes place across an intervening non-conductor or dielectric.

A mechanical strain of the dielectric occurs, which *suddenly* breaks down as it were and per-

mits the discharge to pass as a spark, or rapid succession of sparks.

In air, the spark, when long, generally takes the zigzag path, as shown in Fig. 210.

The sparks produced by disruptive discharges consist of heated gases, together with portions of the conductor that are volatilized by the heat.

The discharge of a *Leyden jar* or *condenser* may be disruptive, as when the discharging rod is held with one knob connected with one coating, and the other near the other coating. It may be gradual, as when the two coatings are alternately connected with the ground. The discharge of a *Leyden jar* as, indeed, the disruptive discharge in general, is *oscillatory*.

The *stress* is often sufficient to pierce the glass.

Discharge, Duration of — — The time required to effect a complete disruptive discharge.

The disruptive discharge is not instantaneous; some time is required to effect it. Estimates of the duration of a flash of lightning based on the duration of a *Leyden jar* discharge, are misleading from the enormous difference in the quantity and the potential in the two cases. The fact that the disruptive discharge is oscillatory and consists of a number of discharges taking place in alternately opposite directions shows that the discharge is not instantaneous.

Leyden jar discharges, are, however, accomplished in very small periods of time.

Discharge, Flaming — — The white and flaming arc-like discharge that occurs between the terminals of the secondary of an induction coil, when, with a great number of alternations per second, the current through the primary is increased beyond that required for the sensitive-thread discharge. (See *Discharge, Sensitive-Thread*.)

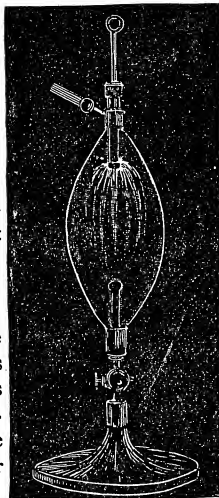

Fig. 209. Discharge in Rarefied Air.

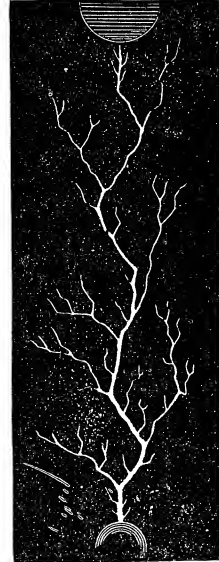

Fig. 210. Disruptive Discharge.

According to Tesla the flaming discharge is best produced when the number of alternations is not too great and certain relations between capacity, self-induction and frequency are observed. These relations must be such as will permit the flow through the circuit of the maximum current, and thus may be obtained with wide variations in the frequency. The flaming discharge develops considerable heat, and is characterized by the absence of the shrill note accompanying less powerful discharges. This is probably due to the enormous frequency.

Some idea of the flaming discharge may be had

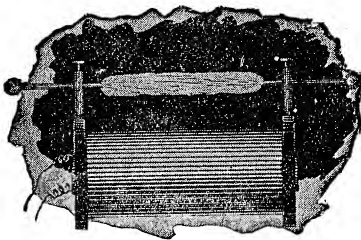

Fig. 211. Flaming Discharge (Tesla).

from an inspection of Fig. 211, taken from Tesla.

• **Discharge, Glow** — —A form of convective discharge. (See *Discharge, Convective*.)

• **Discharge, Impulsive** — —A discharge produced in conductors by suddenly created differences of potential.

Impulsive discharges are influenced more by the inductance of a conductor than by its true ohmic resistance. (See *Inductance, Resistance, Ohmic*.)

A mass of guncotton simply ignited in the open air, produces but little effect on any resisting object placed below it. If, however, it be rapidly ignited by means of a detonator, and is thus fired with much greater rapidity, it may shatter anything placed beneath it.

In a similar manner, a rapidly discharged current, or impulsive discharge, produces, through the inductance of the conductor, a series of effects somewhat similar to the above, in which a great impedance is produced by a sudden change of direction.

Discharge, Induced Currents, Effects Produced by — —Varying classes of effects produced by the discharges of induced currents.

The effects produced by discharges of induced currents are classified by Fleming as follows:

(1.) Effects depending on the entire quantity of the discharge.

a. Galvanometric effects.

If the needle of the galvanometer has a period or time of oscillation that is long, as compared with the time of duration of the discharge, the sine of one-half the angle of deflection is proportional to the whole quantity of the discharge.

b. Electro-chemical effects.

The quantity of an electrolyte broken up is proportional to the quantity of electricity which passes through it.

(2.) Effects depending on the average of the square of the current strength at any instant during the discharge.

a. Heating effects.

The rate of dissipation as heat, according to Joule's law, is proportional to the square of the current strength passing.

b. Electro-dynamic effects.

When a discharge passes through a circuit, part of which is fixed and part movable, the forces of attraction and repulsion which take place between them at any instant are proportional to the square of the current strength.

(3.) Effects depending on rate of change of the current.

a. Physiological effects.

The effect of the discharge in producing physiological shock increases with the suddenness of the discharge. Of two discharges which reached the same maxima that which reached it first would produce the greatest physiological effect. Recent investigations by Tesla and others would appear to partly disprove the above statement.

b. Telephonic effects.

The telephone, like the body of an animal, is affected more by the rate of change than by the current strength at any instant.

c. Magnetic effects.

Rayleigh has shown that the magnetic effects of the discharge depend upon the maximum current strength during the discharge, or upon the initial current strength, in cases where the current dies away gradually. Since the time required for the permanent magnetizing of a steel wire is small compared with the duration of the induced current, the amount of magnetism acquired depends essentially on the initial or maximum current strength during the discharge, irrespective of the time during which said discharge lasts.

d. Luminous effects.

These are also dependent in the case of induced discharges on the rate of change of the current.

Discharge-Key.—(See *Key, Discharge.*)

Discharge, Lateral — —A discharge, taking place on the discharge of a Leyden jar, or other disruptive discharge, between parts of the jar or conductors, not in the circuit of the main discharge.

If a charged Leyden jar is placed on an insulating stool, and is then discharged by the discharging rod, the lateral discharge is seen as a small spark that passes between the outside coating of the jar and a body connected with the earth at the moment of the discharge through the rod.

A *lateral discharge* is also seen in the sparks that can be taken from a conductor in good connection with the earth, by holding the hand near the conductor, while it is receiving large sparks from a powerful machine in operation. These discharges are due to induction.

If a Leyden jar be discharged by means of a conducting wire bent as shown in Fig. 212, in which

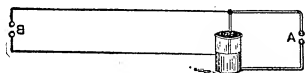

Fig. 212.

two parts of the circuit are closely approached as at A, whenever a spark occurs at B, another spark produced by a lateral discharge occurs at A. Although the resistance of the metallic circuit is enormously less than the resistance of the air space through which the lateral discharge occurs, yet the counter electromotive force produced in the metallic circuit by the impulsive discharge, renders its resistance far greater than that of the air space. The path of a lateral discharge is called the *alternative path*. (See *Path, Alternative.*)

Discharge, Luminous Effects of — —

The luminous phenomena attending and produced by an electric discharge.

The luminous effects vary as to color, intensity, shape and accompanying acoustic phenomena according to a variety of circumstances, the principal of which are as follows, viz.:

(1.) With the kind of gaseous medium through which the discharge passes. Thus, a spark passed through hydrogen has a crimson or reddish color;

through carbonic acid or chlorine, a greenish color.

(2.) With the density of the medium. In a partial vacuum, the discharge from an induction coil becomes an ovoidal mass of light. As the vacuum increases, the light at first grows brighter, but as a higher vacuum is reached, striæ of alternate dark and light bands appear. Finally, with very high vacua the discharge fails to pass. (See *Discharge, Convective.*)

(3.) With the nature of the substances forming the points from which the discharge is taken. This is due to the partial volatilization of the material of the electrodes.

(4.) With the kind of electricity, *i. e.*, whether positive or negative. A positive charge assumes the shape of a fan; a negative discharge, that of a star.

(5.) On the density of the discharge. The introduction of a Leyden jar or condenser in the circuit of a Holtz machine, for example, causes the spark to change from the faint bluish to the silvery white.

(6.) The disruptive discharge through air is attended by snapping or crackling sound, which, in the case of lightning, reaches the intensity of thunder. When the disruptive discharge takes place through a vacuum a faint hissing sound is heard, or all sound may entirely disappear.

(7.) Luminous effects resulting from molecular bombardment occurring in comparatively high vacua. These luminous effects may result:

(a.) From actual incandescence of some refractory material produced by the blows of the molecules; or,

(b.) As a result of phosphorescence or fluorescence due to such blows.

Canary glass, or glass stained by uranium oxide, fluoresces and emits a yellowish green light; solution of sulphate of quinine emits a bluish light.

Discharge, Non-Oscillatory — —A dead-beat discharge. (See *Discharge, Dead-Beat.*)

Discharge, Oscillating — —A number of successive discharges and recharges which occur on the disruptive discharge of a Leyden jar, or condenser.

A discharge which periodically decreases by a series of oscillations.

A discharge which produces a dying-away-backwards and forwards current.

The disruptive discharge of a Leyden jar, or condenser, is not effected by a single rush of electricity. When discharged through a comparatively small resistance, a number of alternate partial discharges and recharges occur, which produce true *oscillations* or *undulatory discharges*.

These oscillations are caused by the *induction of the discharge* on itself, and are similar to the self-induction of a current.

The existence of the oscillating discharge in the case of a Leyden jar or condenser, proves, in the opinion of some, that electricity, taken along with matter, possesses a property similar to inertia.

Discharge, Oscillatory — —A term sometimes used for an oscillating discharge. (See *Discharge, Oscillating*.)

Discharge, Periodic — —An electric discharge which changes its direction at regular intervals or periods.

An alternating discharge.

Discharge, Periodically-Decreasing — —An oscillating discharge whose decrease is periodic. (See *Discharge, Oscillating*.)

Discharge, Sensitive-Thread — —The thin, thread-like discharge that occurs between the terminals of the secondary of an induction coil of high frequency.

The sensitive-thread discharge occurs, according to Tesla, when the number of alternations per

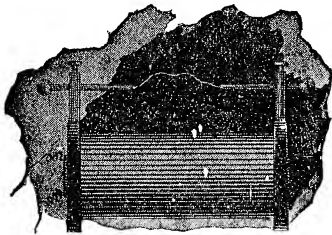

Fig. 213. Sensitive-Thread Discharge (Tesla).

second is high and the current through the primary small. This discharge has the form of a thin, feebly-colored thread. Though very sensitive, being deflected by a mere breath, it is nevertheless quite persistent, if the terminals be at one-third of the striking distance apart. Tesla ascribes its extreme sensitiveness, when long, to the motion of suspended dust particles in the air.

The general appearance of the sensitive-thread discharge is shown in Fig. 213, taken from Tesla.

Discharge, Silent — —A name given to a convective discharge in order to distinguish it from the more noisy disruptive discharge.

The convective discharge in reality is attended by a feeble sound, which, however, is quiet when compared with the more pronounced sound of the disruptive discharge. (See *Discharge, Convective*.)

Discharge, Stratified — —The form of alternate light and dark spaces assumed by the discharges of an induction coil through a partially exhausted gas. (See *Tube, Stratification*.)

The striæ are explained by Curtis as follows: "Under the influence of the electric rhythm of the rapidly following discharges the molecules of the residual gas collect in alternately dense and rarefied spaces. The light bands correspond to the spaces where the molecules are comparatively crowded together, and their concomitant friction produces the luminous disturbance. The dark spaces are where the molecules are further apart, and where their collisions are consequently less frequent."

Discharge, Streaming — —A form assumed by the flaming discharge between the terminals of the secondary of an induction coil when the frequency of the alternations increases beyond a certain limit, and the potential has consequently increased.

The streaming discharge partakes of the general characteristics of the flaming discharge. Luminous streams pass in abundance, not only between the terminals of the secondary, but, according to Tesla, who has carefully studied these phenomena, between the primary and the secondary, through the insulating dielectric separating

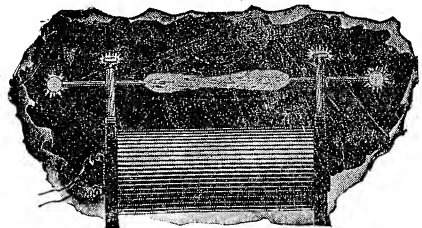

Fig. 214. Streaming Discharge (Tesla).

them. The streams not only pass between the terminals, but also issue from all points and pro-

jections, as will be seen from Fig. 214, taken from Tesla.

When the streaming discharge reaches a certain higher limit it becomes a *brush-and-spray discharge*. (See *Discharge, Brush-and-Spray*.)

The streaming discharge obtained from an induction coil with high frequencies differs from that of an electrostatic machine in that it neither possesses the violet color of the positive static discharge nor the brightness of the negative, but is intermediate in color.

Discharge, Surging — — A term sometimes applied to an oscillatory discharge. (See *Discharge, Oscillatory*.)

Discharge, to Electrically — — To equalize differences of potential by connecting them by means of a conductor.

Discharge, Undulatory — — A discharge, the strength and direction of which gradually change. (See *Currents, Undulatory*.)

Discharge, Unidirectional — — An electric discharge which takes place from the beginning to the end, in one and the same direction.

Discharge, Velocity of — — The time required for the passage of a discharge through a given length of conductor.

According to modern views it is the ether surrounding the wire or conductor which conveys the electric pulses. All the energy which gets into the conductor is dissipated as heat.

The velocity of propagation of discharge of the pulses produced by the oscillating discharge of a Leyden jar through the inter-atomic or intermolecular ether, *i.e.*, through the fixed ether within different substances, varies with the substance. Through free ether the velocity is that of light, or 185,000 miles a second.

The velocity of discharge through long conductors or cables is much lessened by the *capacity* of the cable, and the effects of *induction*, and will therefore vary in different cases. (See *Retardation*.)

Discharger, Universal — — An apparatus for sending the discharge of a powerful Leyden battery or condenser in any desired direction.

The universal discharger consists essentially of

metallic rods, supported on insulated pillars and capable of ready motion, both towards and from one another, as well as in vertical and horizontal planes. The object which is to receive the discharge is placed on an insulated table between the rods, and the latter connected with the opposite coatings of the battery or condenser, when the discharge passes through it.

The term universal discharger is sometimes applied to the discharging tongs.

Discharging, Electrically — — The act of equalizing differences of potential by connection with a conductor.

Discharging Rod.—(See *Rod, Discharging*.)

Discharging Tongs.—(See *Tongs, Discharging*.)

Disconnect.—To break or open an electric circuit.

Disconnecter.—A key or other device for opening or breaking a circuit.

Disconnecting.—The act of opening or breaking an electric circuit.

Disconnection.—A term employed to designate one of the varieties of faults caused by the accidental breaking or disconnection of a circuit.

Disconnections of this kind may be:

(1.) *Total*; as by a switch inadvertently left open; or by the accidental breaking of a part of the circuit.

(2.) *Partial*; as by a dirty contact; a loose, or badly soldered joint; a poorly clamped binding screw; a loose terminal, or a bad earth.

(3.) *Intermittent*; as by swinging joints, alternate expansions or contractions on changes of temperature; the collection of dust and dirt in dry weather, and their washing out in wet weather.

Disconnection, Intermittent — — Any fault in a line which occurs at intervals or intermittently.

Disconnection, Partial — — A partial fault in a line caused by any imperfect contact.

Disconnection, Total — — A fault in a line occasioned by a complete break in the circuit.

Disguised Electricity.—(See *Electricity, Disguised*.)

Disjuncter.—A device employed in a system for the distribution of electric energy by means of continuous currents by condensers, for the purpose of periodically reversing the constant current sent over the line. (See *Electricity, Distribution of, by Continuous Current by Means of Condensers.*)

Dispersion Photometer.—(See *Photometer, Dispersion.*)

Displacement Current.—(See *Current, Displacement.*)

Displacement, Electric — —A displacement of electricity in a uniform and non-crystalline dielectric when lines of electrostatic or magnetic force pass through it.

The quantity of electricity displaced in any homogeneous, non-crystallizable dielectric, by the action of an electric force through the unit area of cross-section, taken perpendicular to the direction of the electric force.

Electric displacement is produced under an elastic strain, which continues only while the electric force is acting.

Displacement, Electric, Lines of — — Lines of electric induction along which electric displacement takes place.

Displacement, Electric, Oscillatory — —A displacement of electricity in a dielectric or non-conductor of an oscillatory character.

Displacement, Electric, Theory of — —A theory which regards the electricity produced on an insulated conductor, by induction through a dielectric, as displaced out of the dielectric on to the conductor, or into the dielectric from the conductor, by the influence of the electric force.

This conception was introduced into science by Maxwell, after a careful study of Faraday's denial of action at a distance.

Suppose a small insulated sphere to receive a charge of electricity $+Q$. It will, by induction, produce an equal and opposite charge $-Q$, on the inner surface, and a similar charge on the outer surface of the small hollow sphere, placed near it, but separated by the dielectric. There has, therefore, been a displacement of electricity through the dielectric. The medium of the

dielectric has connected the two bodies, and the phenomena have appeared by the action of the electric force on the substance of the dielectric; or, in other words, there has been no action at a distance.

According to this conception, an electric current, called a displacement current, exists in the dielectric, while displacement is taking place.

Displacement Waves.—(See *Waves, Displacement.*)

Disruptive Electric Conduction.—(See *Conduction, Electric, Disruptive.*)

Dissimulated or Latent Electricity.—(See *Electricity, Dissimulated or Latent.*)

Dissipation of Charge.—(See *Charge, Dissipation of.*)

Dissipation of Energy.—(See *Energy, Dissipation of.*)

Dissipation of Energy, Hysteresial — —(See *Energy, Hysteresial, Dissipation of, Hysteresis.*)

Dissipation, Specific Hysteresial — — The specific loss of energy by hysteresis in the case of a particular substance. (See *Hysteresis.*)

Dissociate.—To separate a compound substance into its constituents.

Dissociation.—The separation of a chemical compound into its constituent parts.

Dissymmetrical Induction of Armature.—(See *Armature, Dissymmetrical Induction of.*)

Dissymmetrical Magnetic Field.—(See *Field, Magnetic, Dissymmetrical.*)

Dissymmetry of Commutation.—(See *Commutation, Dissymmetry of.*)

Distance, Critical, of Lateral Discharge Through an Alternative Path — —The distance at which a discharge will take place through an air space of given dimensions, in preference to passing through a metallic circuit of comparatively small resistance.

Distance, Explosive — —A term sometimes employed for sparking distance. (See *Distance, Sparking.*)

Distance, Sparking — —The distance

at which electrical sparks will pass through an intervening air space. (See *Spark, Length of.*)

Distant Station.—(See *Station, Distant.*)

Distillation, Destructive — —The action of heat on an organic substance, while out of contact with air, resulting in the decomposition of the substance into simpler and more stable compounds.

The different products resulting from destructive distillation may be successively collected by the ordinary processes of distillation.

Distillation, Dry — —A species of destructive distillation. (See *Distillation, Destructive.*)

Distillation, Electric — —The distillation of a liquid in which the effects of heat are aided by an electrification of the liquid.

Beccaria discovered that a liquid evaporates more rapidly when electrified than when unelectrified. Crookes has shown that evaporation is aided by negative electrification, or that evaporation takes place more rapidly at the negative terminal during a discharge than at the positive. (See *Evaporation, Electric.*)

Distributing Box of Conduit.—(See *Box, Distributing, of Conduit.*)

Distributing Station.—(See *Station, Distributing.*)

Distributing Switch for Electric Light.—(See *Switch, Distributing, for Electric Lights.*)

Distribution-Box for Arc Light Circuits.—(See *Box, Distribution, for Arc Light Circuits.*)

Distribution, Centre of — —In a system of multiple-distribution, any place where branch cut-outs and switches are located in order to control communication therewith.

The electrical centre of a system of distribution as regards the conducting network.

Distribution of Charge.—(See *Charge, Distribution of.*)

Distribution of Electricity.—(See *Electricity, Distribution of.*)

Distribution of Electricity by Alternating Currents — —(See *Electricity, Distribution of, by Alternating Currents.*)

Distribution of Electricity by Alternating Currents by Means of Condensers.—(See *Electricity, Distribution of, by Alternating Currents by Means of Condensers.*)

Distribution of Electricity by Commutating Transformers.—(See *Electricity, Distribution of, by Commutating Transformers.*)

Distribution of Electricity by Constant Potential Circuit.—(See *Electricity, Multiple Distribution of, by Constant Potential Circuit.*)

Distribution of Electricity by Continuous Current by Means of Transformers.—(See *Electricity, Distribution of, by Continuous Current by Means of Transformers.*)

Distribution of Electricity by Motor-Generators.—(See *Electricity, Distribution of, by Motor-Generators.*)

Distribution, Series, of Electricity by Constant Current Circuit.—(See *Electricity, Series Distribution of, by Constant Current Circuit.*)

District Call-Box.—(See *Box, District Call.*)

Diurnal Inequality of Earth's Magnetism.—(See *Inequality, Diurnal, of Earth's Magnetism.*)

Divided Magnetic Circuit.—(See *Circuit, Divided Magnetic.*)

Door-Opener, Electric — —A device for opening a door from a distance by electricity.

Various devices consisting of electro-magnets, acting against, or controlling springs or weights, are employed for this purpose.

Dosage, Electro-Therapeutical — — The apportioning of the amount of the current and the duration of its application to the body for the treatment of disease.

Dosage, Galvanic — —Electro-therapeutical dosage. (See *Dosage, Electro-Therapeutical.*)

Dotting Contact.—(See *Contact, Dotting.*)

Double-Break Knife Switch.—(See *Switch, Double-Break Knife.*)

Double-Carbon Arc Lamp.—(See *Lamp, Electric Arc, Double-Carbon.*)

Double-Cone Insulator.—(See *Insulator, Double-Cone.*)

Double-Connector.—(See *Connector, Double.*)

Double-Contact Key.—(See *Key, Double-Contact.*)

Double-Cup Insulator.—(See *Insulator, Double-Cup.*)

Double-Curb.—(See *Curb, Double.*)

Double-Curb Signaling.—(See *Signaling, Curb, Double.*)

Double-Current Signaling.—(See *Signaling, Double-Current.*)

Double-Current Translator.—(See *Translator, Double-Current.*)

Double-Current Transmitter.—(See *Transmitter, Double-Current.*)

Double-Current Working — —The employment, in systems of telegraphy, by means of suitable keys, of currents from voltaic batteries, in alternately opposite directions, thus increasing the speed of signaling. (See *Working, Reverse-Current.*)

Double-Fluid Electrical Hypothesis.—(See *Electricity, Double-Fluid Hypothesis of.*)

Double-Fluid Voltaic Cell.—(See *Cell, Voltaic, Double-Fluid.*)

Double-Magnet Dynamo-Electric Machine.—(See *Machine, Dynamo-Electric, Double-Magnet.*)

Double-Pen Telegraphic Register.—(See *Register, Double-Pen, Telegraphic.*)

Double-Refraction.—(See *Refraction, Double.*)

Double-Refraction, Electric.—(See *Refraction, Double, Electric.*)

Double-Shackle Insulator.—(See *Insulator, Double-Shackle.*)

Double-Shed Insulator.—(See *Insulator, Double-Shed.*)

Double-Tapper Key.—(See *Key, Double-Tapper.*)

Double-Touch, Magnetization by — — A method for producing magnetization by the simultaneous touch of two magnet poles. (See *Magnetization, Methods of.*)

Double-Transmission.—(See *Transmission, Double.*)

Double-Trolley.—(See *Trolley, Double.*)

Doubler of Electricity.—An early form of continuous electrophorus. (See *Electrophorus.*)

Drifting Torpedo.—(See *Torpedo, Drifting.*)

Drill, Electro-Magnetic — —A drill applied especially to blasting or mining operations, operated by means of electricity.

Drip Loop.—(See *Loop, Drip.*)

Driven Pulley.—(See *Pulley, Driven.*)

Driven Shaft.—(See *Shaft, Driven.*)

Driving Pulley.—(See *Pulley, Driving.*)

Driving Shaft.—(See *Shaft, Driving.*)

Driving Spider.—(See *Spider, Driving.*)

Drop, Annunciator — —A movable signal operated by an electro-magnet, and placed on an annunciator, the dropping of which indicates the closing or opening of the circuit with which the electro-magnet is connected.

The falling of the drop may be attended by the sounding of a bell or other alarm, or, it may give a silent indication.

Drop, Annunciator, Automatic — —A drop for an annunciator, which on the closing of a circuit, falls and holds the circuit closed until the drop is raised.

Drop, Annunciator, Gravity — —A drop for an annunciator, acted on by gravity when released by the movement of the armature of an electro-magnet.

Drop, Automatic — —A device for automatically closing the circuit of a bell and holding it closed until stopped by resetting a drop.

The automatic drop is especially applicable to burglar alarms. On the opening of a door or shutter, the closing of the circuit moves the armature of an electro-magnet, and, by the falling of a drop, closes the circuit and holds it closed until mechanically opened by the replacing of the drop. The general appearance of the automatic drop is shown in Fig. 215.

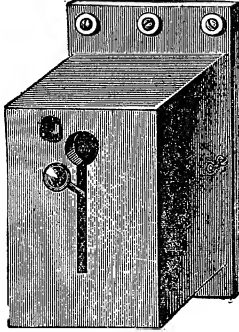

Fig. 215. Automatic Drop.

Drop, Calling

— — An annunciator drop employed to indicate to the operator in a telegraphic or telephonic system that one subscriber wishes to be connected with another.

Drop of Potential.—(See *Potential, Drop of*.)

Drops, Clearing Out — — Restoring the drops of annunciators to their normal position after they have been thrown out of the same by the closing of the circuits of their magnets.

These clearing-out devices as placed on most forms of annunciators are generally mechanical in operation.

Drum Armature.—(See *Armature, Drum*.)

Drum, Electro-Magnetic — — A drum, used in feats of legerdemain, operated by an automatic electro-magnetic make and break apparatus.

Dry Distillation.—(See *Distillation, Dry*.)

Dry Electrode.—(See *Electrode, Dry*.)

Dry Pile.—(See *Pile, Dry*.)

Dry Voltaic Cell.—(See *Cell, Voltaic, Dry*.)

Dub's Laws.—(See *Laws, Dub's*.)

Duplex Cable.—(See *Cable, Duplex*.)

Duplex Cut-Out.—(See *Cut-out, Duplex*.)

Duplex Flat Cable.—(See *Cable, Flat Duplex*.)

Duplex Telegraphy.—(See *Telegraphy, Duplex*.)

Duplex Wire.—(See *Wire, Duplex*.)

Duration of Electric Discharge.—(See *Discharge, Duration of*.)

Duration of Make-Induced Current.—(See *Current, Make or Break Induced, Duration of*.)

Dust Figures, Lichtenberg's — — (See *Figures, Lichtenberg's Dust*.)

Dyad.—A chemical element which has two bonds by which it can unite or combine with another element.

An element whose atomicity is bivalent.

Dyeing, Electric — — The application of electricity either to the reduction or the oxidation of the salts used in dyeing.

Goppelsröder, in his processes of *electric dyeing*, forms and fixes aniline black on cloth as follows, viz.: the cloth, saturated with an aniline salt, is placed on an insulated metallic plate, inert to the aniline salt, and connected with one pole of a battery or other electric source. The other pole is connected with a metallic plate on which the required design is drawn. On the passage of the current, the design is traced in aniline black on the cloth. A minute or two suffices for the operation.

A species of electrolytic writing is obtained on cloths arranged as above by substituting a carbon pencil for the metallic plate. On writing with this pencil, as with an ordinary pencil, the passage of the current so directed is followed by the deposition of aniline black.

By means of a somewhat similar process writing in white on a colored ground is obtained.

Dynamic Electricity.—(See *Electricity, Dynamic*.)

Dynamics, Electro — — That branch of electric science which treats of the action of electric currents on one another and on themselves or on magnets.

The principles of electro-dynamics were discovered by Ampère in 1821.

A convenient form of apparatus, for showing experimentally the action of one current on another, consists of two upright metallic columns

or pillars, which support horizontal metallic arms containing mercury cups, *y*, and *c*, Fig. 216.

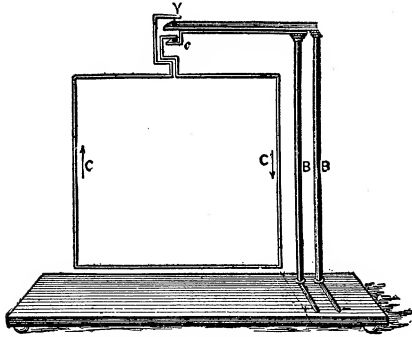

Fig. 216. Deflection of a Circuit by a Current.

The circuit is bent in the form of a rectangle, circle or solenoid, and terminates in points that dip in the mercury cups. The current is led into and out of the apparatus at the points + and - at the base of the upright supports.

When a magnet, or another circuit, is approached to the movable circuit thus provided, attractions or repulsions are produced according to the position of the magnet, or the direction of the currents in the two circuits.

If a magnet *A B*, Fig. 217, be placed, as shown,

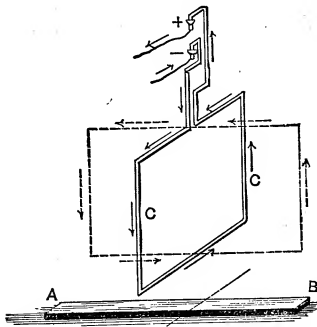

Fig. 217. Deflection of Circuit by a Magnet.

below the movable circuit *C C*, the circuit will tend to place itself at right angles to the axis of the magnet. This movement is the same as would occur if electric currents were circulating around the magnet in the direction of the assumed *Ampèrian currents*. It also illustrates the principle of the electric motor. (See *Magnetism, Ampère's Theory of*.)

Ampère has given the results of his investigations as to the mutual attractions and repulsions of cur-

rents in the following statements, which are known as *Ampère's Laws*:

(1.) Parallel portions of a circuit attract one another if the currents in them are flowing in the same direction, and repel one another if the currents are flowing in opposite directions.

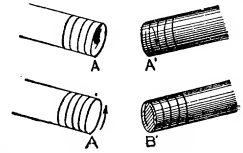

Fig. 218. Action of Solenoid Poles.

A current flowing through a spiral tends to shorten the spiral from the attraction of the parallel currents in contiguous turns.

Similar poles of two solenoids repel each other, as at *A, A'*, Fig. 218, because, when opposed to each other, the currents that produce these poles

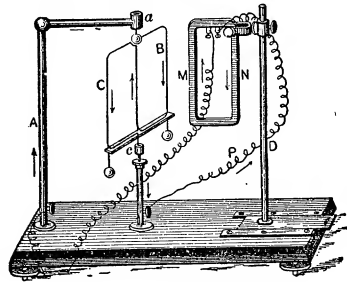

Fig. 219. Ampère's Stand.

are flowing in opposite directions, as may be seen from an inspection of the drawing.

Dissimilar solenoid poles, on the contrary, attract each other as at *A, B*, in Fig. 218, since

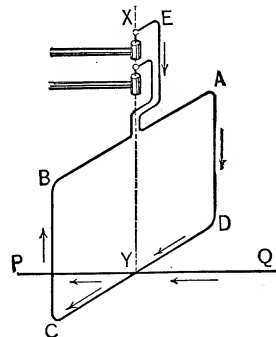

Fig. 220. Electro-Dynamic Attraction.

the currents which produce them flow in the same direction.

In Fig. 219, a form of Ampère's stand is shown, in which one of the circuits is in the form of the

coil M N; its action on the movable circuit C B, is to repel it, since the currents, as shown, are flowing in an opposite direction in the adjacent portions of the fixed and movable circuits.

(2.) Two portions of a circuit intersecting each other mutually attract each other when the currents in both circuits flow either *towards* or *from* the point of intersection, but repel each other if they flow in opposite directions from this point.

Thus, in Fig. 220, the currents in both circuits P Q and A B C D, flow towards and from the point of intersection Y, and attract one another and cause a motion until the two circuits are parallel.

If the currents flow in opposite directions they repel each other, and, if free to move, will come to rest when parallel to each other; therefore, two portions of a circuit crossing each other tend to move until they are parallel, and their currents are flowing in the same direction.

(3.) Successive portions of the circuit of the same *rectilinear current*, that is, a current flowing in the same straight line, repel one another.

A circuit O A, Fig. 221, movable on O, as a

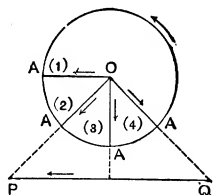

Fig. 221. Continuous Rotation of Current.

(1.) That parallel currents flowing in the same direction attract, because their lines of force have opposite directions in adjoining parts of the circuit of these lines.

(2.) That parallel currents flowing in opposite directions repel, because their lines of force have the same directions in adjoining parts of the circuit.

These laws may therefore be generalized thus, viz.: Lines of magnetic force extending in opposite directions attract one another; lines of magnetic force extending in the same direction repel one another.

Ampère proved that a circuit, doubled on itself so that the current flows in opposite directions in the two parts, exerts no force on external objects. This expedient is adopted in resistance coils to prevent any disturbance of the galvanometer needles. He also showed that a *sinuous circuit*, or one bent into zigzags, produces the same effects of attraction or repulsion as it would if it were straight. (See *Coil, Resistance*.)

The term *sinuous current* is sometimes applied to the current in a sinuous circuit. (See *Current, Sinuous*.) This must be distinguished from the term *sinusoidal current*, which applies to fluctuations in the current and not to peculiarities in the shape of the conductor.

When two inclined magnets, free to move, are left to their mutual attractions and repulsions, they gradually come to rest with their axes parallel to each other.

Two conductors through which electric currents are flowing act on one another as two magnets would.

A conductor conveying a current of electricity tends to rotate round a magnetic pole. A magnetic pole tends to rotate continuously round an electric current.

The motion of a magnet near a conductor produces an electromotive force in that conductor provided the conductor cuts the lines of force.

A magnetized substance becomes magnetized when placed in a magnetic field.

A conductor through which a current of electricity is passing tends to wrap itself around a neighboring magnetic pole. The following experiments illustrate this tendency:

(1.) The experiment suggested by Lodge: A powerful current of electricity is passed through some eight feet in length of gold thread such as is employed for making lace. The thread is hung in a vertical position, near a vertical bar

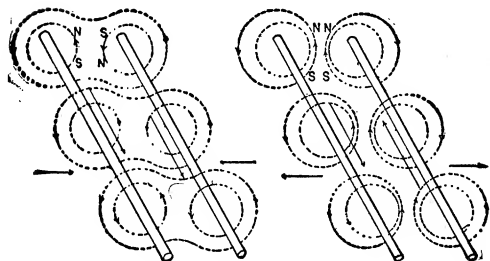

Fig. 222. Mutual Action of Magnetic Fields.

centre, will be continuously rotated in the direction of the curved arrow by the rectilinear current, P Q; for, the directions of the currents being as shown by the arrows, there will be attraction in the positions (1) and (2), and repulsion in position (4).

The cause of the mutual attractions and repulsions of electric circuits will readily appear from a consideration of the mutual action of their magnetic fields.

Thus an inspection of Fig. 222 shows :

magnet. As soon as the current passes, the thread will wrap itself around the bar magnet, one half of it twisting itself round the north pole, the other half round the south pole.

(2.) The experiment suggested by Professor S. P. Thompson: An electric current is sent through a stream of mercury while it is flowing between two poles of a powerful electro-magnet; when the current is sent through the magnet, the stream is twisted in spiral directions which vary, either with the direction of the current, or with the direction of the magnetic polarity.

(3.) Somewhat similar effects can be shown by the rotation of a stream of gas round a magnetic pole placed in an exhausted glass receiver.

Dynamo.—The name frequently applied to a dynamo-electric machine used as a generator. (See *Machine, Dynamo-Electric.*)

Dynamo Balancing Rheostat.—(See *Rheostat, Dynamo Balancing.*)

Dynamo-Battery.—(See *Battery, Dynamo.*)

Dynamo Brush Trimmer.—(See *Trimmer, Dynamo Brush.*)

Dynamo, Composite-Field — —A dynamo whose field coils are series and separately excited.

Additional separately excited coils placed on the field of a series wound dynamo render it self-regulating.

A composite dynamo is a form of compounded dynamo.

Dynamo, Compound-Wound.—A compound-wound dynamo-electric machine. (See *Machine, Dynamo-Electric, Compound-Wound.*)

Dynamo, Contact — —A form of dynamo in which the space between the armature and field magnet poles is so reduced that they actually touch one another.

In contact dynamos both field and armature revolve. This form of dynamo has not been very successful in practice.

Dynamo-Electric Machine.—(See *Machine, Dynamo-Electric.*)

Dynamo-Electric Machine, Alternating Current — —(See *Machine, Dynamo-Electric, Alternating Current.*)

Dynamo-Electric Machine Armature.—(See *Armature, Dynamo-Electric Machine.*)

Dynamo-Electric Machine Armature Coils.—(See *Coils, Armature, of Dynamo-Electric Machine.*)

Dynamo-Electric Machine Armature Core.—(See *Core, Armature, of Dynamo-Electric Machine.*)

Dynamo-Electric Machine Battery.—(See *Battery, Dynamo-Electric Machine.*)

Dynamo-Electric Machine, Bi-Polar — —(See *Machine, Dynamo-Electric, Bi-Polar.*)

Dynamo-Electric Machine, Collecting Brushes of — —(See *Brushes, Collecting, of Dynamo-Electric Machine.*)

Dynamo-Electric Machine Commutator — —(See *Commutator, Dynamo-Electric Machine.*)

Dynamo-Electric Machine, Compound-Wound — —(See *Machine, Dynamo-Electric, Compound-Wound.*)

Dynamo-Electric Machine, Generation of Current by — —(See *Current, Generation of, by Dynamo-Electric Machine.*)

Dynamo-Electric Machine, Field Magnets — —(See *Magnets, Field, of Dynamo-Electric Machine.*)

Dynamo-Electric Machine, Methods of Increasing the Electromotive Force Generated by — —(See *Force, Electromotive, Generated by Dynamo-Electric Machine, Method of Increasing.*)

Dynamo-Electric Machine, Mouse-Mill, Sir William Thomson's — —(See *Machine, Dynamo-Electric, Mouse-Mill, Sir William Thomson's.*)

Dynamo-Electric Machine, Multipolar — —(See *Machine, Dynamo-Electric, Multipolar.*)

Dynamo-Electric Machine, Pole-Pieces of — —(See *Pole-Pieces of Dynamo-Electric Machine.*)

Dynamo-Electric Machine, Reversibility of — —(See *Machine, Dynamo-Electric, Reversibility of.*)

Dynamo-Electric Machine, Varieties of — (See *Machine, Dynamo-Electric, Varieties of.*)

Dynamo, Inductor — — A dynamo-electric machine for alternating currents in which the differences of potential causing the currents are obtained by magnetic changes in the cores of the armature and field coils by the movement past them of laminated masses of iron inductors.

The coils corresponding to the armature and field magnets of the ordinary dynamo are stationary. The laminated masses of iron, employed to cause magnetic changes in the cores of the field and armature coils, are fixed on an inductor wheel which is rapidly revolved in front of them. The magnets corresponding to the field magnets are called the primary poles, and are magnetized by an exciter. The magnets corresponding to the armature are called the secondary poles and are placed so as to alternate with the primary poles. The inductors are so shaped that they carry the magnetism of one pole of the primary magnet to the secondary poles when the inductor is in one position, and of the opposite pole when in a slightly different position. The inductor wheel therefore acts as a magnetic commutator and changes the position of the secondary magnet as it rotates, thus producing electromotive force. The number of alternations per revolution is equal to twice the number of inductors placed on the inductor wheel.

Dynamo, Inverted — — A dynamo-electric machine in which the armature bore or chamber is placed below the field magnet coils.

The term inverted is used in contradistinction to the overtype dynamo. (See *Dynamo, Overtype.*)

Dynamo, Mouse Mill — — A form of dynamo-electric machine designed by Sir William Thomson to act as the replenisher of one of his electrometers. (See *Replenisher.*)

Dynamo, Multiphase — — A polyphase dynamo. (See *Dynamo, Polyphase. Dynamo, Rotating Current.*)

Dynamo, Overtype — — A dynamo-electric machine, the armature bore or chamber of which is placed above the field magnet coils instead of below them as in many forms.

The overtype form of dynamo possesses the advantage of better avoiding magnetic leakage.

Dynamo, Polyphase — — A name sometimes applied to a rotating current dynamo. (See *Dynamo, Rotating Current.*)

Dynamo, Pyromagnetic — — A name sometimes applied to a pyromagnetic generator. (See *Generator, Pyromagnetic.*)

Dynamo, Rotary-Phase — — A term sometimes employed for a rotating current dynamo. (See *Dynamo, Rotating Current.*)

Dynamo, Separately-Excited — — A separately-excited dynamo-electric machine. (See *Machine, Dynamo-Electric, Separately-Excited.*)

Dynamo, Series — — A series-wound dynamo-electric machine. (See *Machine, Dynamo-Electric, Series-Wound.*)

Dynamo, Shunt — — A shunt-wound dynamo-electric machine. (See *Machine, Dynamo-Electric, Shunt-Wound.*)

Dynamograph. — A term sometimes applied to a type-writing telegraph that records the message in type-written characters, both at the sending and the receiving ends.

Dynamometer. — A name given to a variety of apparatus for measuring the power of an engine or motor.

In all dynamometers the strain on the belt or other moving part is measured, say in pounds, and the speed of the moving part is also measured in feet per second. The product of the strain in

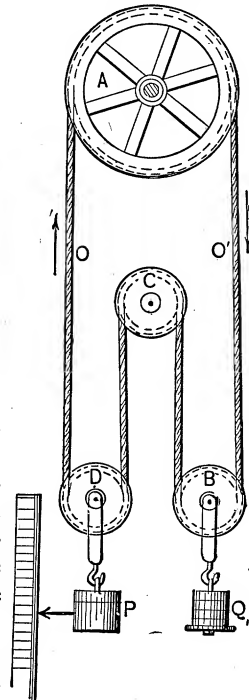

Fig. 223. Parsons' Dynamometer.

pounds by the velocity in feet per second, divided by 550, will give the horse power.

One of the many forms of dynamometers is shown in Fig. 223. It is known as Parsons' Dynamometer.

The driving pulley is shown at A, and the driven pulley at C. Weights hung at Q_1 , are varied so as to maintain the axes of the suspended pulleys, D and B, as nearly as possible at the same height. Then the tension T_1 and T_2 , on the sides O and O', of the belts, will be represented by the following equation :

$$T_2 - T_1 = \frac{P - Q}{2},$$

from which, knowing the belt speed, the horse power may be deduced.

There are several other forms of dynamometer, such as the cradle dynamometer, in which the machine is supported on knife edges and the torque or pull exerted on or by the machine is balanced by weights sliding on a lever. In these dynamometers the power is transmitted through them and they are therefore called transmission dynamometers.

Dynamometer, Electro — — A form of galvanometer for the measurement of electric currents.

In Siemens' Electro-Dynamometer, shown in Fig. 224, there are two coils; a fixed coil, C, secured to an upright support, and a movable coil, L, consisting often of but a single turn of wire. The movable coil is suspended by means of a thread and a delicate spring, S, capable of being twisted by turning a milled screw-head through an angle of torsion measured on a scale by means of an index connected to the screw-head. The two ends of the movable coil dip into mercury cups so connected that the current to be measured passes through the fixed and movable coils in series.

When ready for use the movable coil is at right angles to the fixed coil. The current to be measured is then sent into the coils, and their mutual action tends to place the movable coil parallel to the fixed coil against the torsion of the spring, S. The amount of this force can be ascertained by determining the amount of torsion required to bring the movable coil back to its zero position.

Since the same current passes through both the fixed and movable coils, and they both act on each other, the deflecting force here is evidently proportional to the square of the strength of the

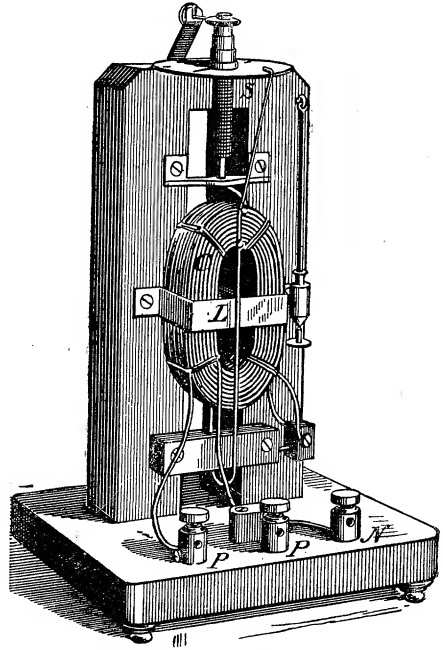

Fig. 224. Siemens' Electro-Dynamometer.

current to be measured. The deflecting force, and consequently the current strength, is therefore proportional to the square root of the angle of torsion, and not directly to the angle of torsion.

Dyne.—The unit of force.

The force which in one second can impart a velocity of 1 centimetre per second to a mass of 1 gramme.

The dyne is the unit of force, or a force capable, after acting for one second on a mass of 1 gramme, of giving it a velocity of 1 centimetre per second. The weight of a body in dynes, or the force with which it gravitates, is equal to its mass in grammes, multiplied by the acceleration imparted to it in centimetres per second. For this latitude the acceleration is about 981 centimetres per second.

E

E.—A contraction sometimes used for earth.

A contraction sometimes used for electromotive force, or E. M. F., as in the well-known formula for Ohm's law,

$$C = \frac{E}{R}$$

E. M. D. P.—A contraction for electromotive difference of potential. (See *Potential, Difference of, Electromotive.*)

E. M. F.—A contraction generally used for electromotive force. (See *Force, Electromotive.*)

Earth.—A fault in a telegraphic or other line, caused by accidental contact of the line with the ground or earth, or with some conductor connected with the latter.

This is more frequently called a ground.

Earths are of three kinds, viz.:

- (1.) *Dead or Total Earth.*
- (2.) *Partial Earth.*
- (3.) *Intermittent Earth.*

The term earth is also applied to a plate buried in the ground, and intended to make a good contact between the earth and a wire circuit, which is connected with the plate.

Earth Circuit.—(See *Circuit, Earth.*)

Earth-Circuited Conductor.—(See *Conductor, Earth-Circuited.*)

Earth Currents.—Electric currents flowing through different parts of the earth caused by a difference of potential at different points.

The causes of these differences of potential are various and are not well understood.

Earth, Dead or Total — —A fault in a telegraphic or other line in which the line is thoroughly grounded or connected with the earth.

Dead earth is sometimes called *total earth.*

Earth-Grounded Wire.—(See *Wire, Earth-Grounded.*)

Earth, Intermittent — —A swinging earth. (See *Earth, Swinging or Intermittent.*)

Earth or Ground.—That part of the earth

or ground which forms part of an electric circuit.

A circuit is put to *earth* or *ground* when the earth is used for a portion of the circuit.

The resistance of an earth connection may vary in time from the following causes, viz.:

- (1.) The corrosion of the ground plate. This is especially apt to occur in the case of a copper plate.
- (2.) From polarization, a counter-electromotive force being produced, thus introducing a *spurious resistance* into the circuit. (See *Resistance, Spurious.*)

Earth, Partial — —A fault in a telegraphic or other line in which the line is in partial connection with the earth.

The term partial earth is used in contradistinction to dead or total earth.

Earth, Return — —A circuit in which the return current passes back to the source through the earth.

Earth, Swinging or Intermittent — —A fault in a telegraphic or other line in which the action of the wind, or occasional expansion by heat, brings the line into intermittent contact with the earth.

Earth, Total — —A term sometimes used for dead earth. (See *Earth, Dead or Total.*)

Ebonite.—A tough, hard, black substance, composed of india rubber and sulphur, which possesses high powers of insulation and of specific inductive capacity.

Ebonite is often called vulcanite.

Vulcanite rubbed with cat-skin acts as one of the best known substances for becoming electrified by friction. For this purpose both substances should be thoroughly dried.

Economic Co-efficient of Dynamo-Electric Machine.—(See *Co-efficient, Economic, of a Dynamo-Electric Machine.*)

Eddy Currents.—(See *Currents, Eddy.*)

Eddy Currents, Deep-Seated — —(See *Currents, Eddy, Deep-Seated.*)

Eddy Currents, Superficial — —(See *Currents, Eddy, Superficial.*)

Eddy-Displacement Currents.—(See *Currents, Eddy-Displacement*.)

Eel, Electric — —An eel possessing the power of giving powerful electric shocks. The gymnotus electricus.

The electricity is produced by an organ extending the entire length of the body.

According to Faraday, the shock given by a specimen of the animal examined by him was equal to that of 15 Leyden jars, having a total surface of 25 square feet. Fig. 225 shows the general appearance of the animal.

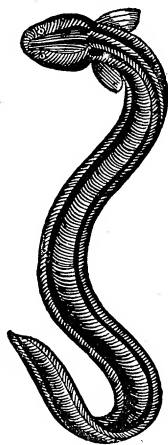

Fig. 225. *Electric Eel.*

Effect, Acheson — — The increase in the electromotive force of the secondary of a transformer by the action of the changes in temperature of its core. (See *Electricity, Cal.*)

Effect, Chemical — — The effect occasioned by atomic combination, which results in a loss of those properties or peculiarities by which the substances entering into combination are ordinarily recognized.

Atomic combination, resulting in the formation of new molecules.

The formation of new molecules necessitates the possession by the new substance of properties distinct and separate from those of its constituents.

Black carbon, and yellow sulphur, for example, both solids, unite chemically to form a transparent colorless liquid.

Chemical changes differ from physical changes, which latter can occur in a substance without the formation of new molecules, and consequently without the loss by it of the properties it ordinarily possesses.

Thus a sheet of vulcanite, electrified by friction, still retains its characteristic density, shape, color, etc.

Effect, Counter-Inductive — — The opposal of current or charge by means of a counter-electromotive force produced by induction.

In the Thomson counter-electromotive force lightning arrester, a counter-electromotive force, produced by the inductive effects of the passage of the bolt to earth, protects the instrument by opposing the passage of the bolt. (See *Arrester, Lightning, Counter-Electromotive Force.*)

Effect, Edison — — An electric discharge which occurs between one of the terminals of the incandescent filament of an electric lamp, and a metallic plate placed near the filament but disconnected therefrom, as soon as a certain difference of potential is reached between the lamp terminals.

The effect of the discharge is to produce a current in a circuit connected to one pole of the lamp terminals and the metallic plate, as may be shown by means of a galvanometer.

Effect, Electrotonic — — An altered condition of excitability of a nerve produced when in the electrotonic state. (See *Electrotonus.*)

Effect, Faraday — — The rotation of the plane of polarization of a beam of plane polarized light by its passage through a magnetic field.

Lodge suggests the following explanation for the Faraday effect: As is well known, a strongly magnetized medium possesses a different magnetic susceptibility to additional magnetizing forces in the same direction than it does in the opposite direction. It therefore follows that the vibrations are resolved into two opposed circular components, which travel through the medium with different rates of velocity, since one tends to magnetize it and the other to demagnetize it. The plane of rotation will therefore be rotated.

He also suggests the following explanation for the Faraday effect, viz.: He assumes that the Ampèrian molecular currents in such substances as exhibit rotation in a magnetic field do not consist of two equal and opposite electrical currents, but that one of the currents is slightly stronger than the other. Suppose, for example, that in iron the positive Ampèrian current is weaker than the negative, and that the ether as a whole is rotating with the negative current. Any ethereal vibration entering such a medium will begin to screw itself in the direction opposed to that of the magnetizing current. In copper, or other similar substances, the rotation should take place in the opposite direction.

Effect, Ferranti — — An increase in the electromotive force, or difference of potential, of mains or conductors towards the end of the same farthest from the terminals that are connected with a source of constant potential.

The Ferranti effect refers to the increase of the electromotive force on the mains employed in systems for the transmission of electrical energy by means of alternating currents. It was found, for example, in the currents used on the mains connected with one of Mr. Ferranti's alternating dynamos and leading to the town of Deptford, that instead of finding a drop of potential at the ends of the mains farthest from the dynamo, as was expected, a notable increase in the potential occurred. These effects were observed during the laying of the mains. Testing the potential by placing an incandescent lamp in the circuit across the mains, the increase of the potential with the increase of the length of the main was shown by the increased brilliancy of the light of the incandescent lamp.

Various explanations have been given as the cause of the Ferranti effect.

Effect, Hall — — A transverse electromotive force, produced by a magnetic field in substances undergoing electric displacement.

This transverse electromotive force is probably

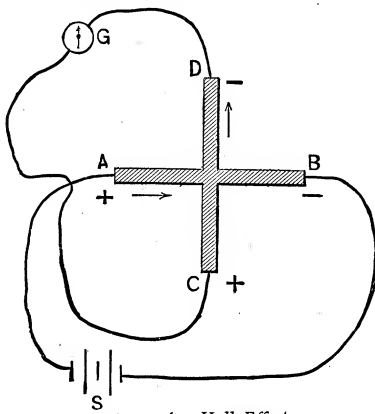

Fig. 226. Hall Effect.

due to magnetic whirls, in a manner similar to the Faraday effect.

The Hall effect is produced by placing a very thin metallic strip, conveying an electric current, in a strong magnetic field.

The cross A B C D, Fig. 226, is cut out of a

gold leaf or other very thin metallic sheet. The ends A and B, are connected with the terminals of a battery S, and the ends C and D, with the galvanometer G.

None of the battery current can therefore flow through the galvanometer.

If, now, the metallic cross be placed in a powerful magnetic field, the lines of force of which are perpendicular to the plane of the cross, the deflection of the galvanometer needle will show the existence of a current, which, if the battery current flows in the direction of the arrow, or from A, to B, and the lines of magnetic force pass through the paper from the *front to the back of the sheet*, when the cross is formed of gold, silver, platinum or tin-foil, will flow through C D, from C to D, but in the opposite direction if formed of iron. These effects cease if the conductor is increased in thickness beyond a certain extent.

As regards the production of the Hall effect by the influence of a magnetic field on conductors, Mr. Shelford Bidwell suggests that since magnetism affects the conductivity of metals in a complicated manner, it is possible that metallic substances conveying an electric current in a magnetic field are more or less strained by the mechanical forces, and that, therefore, heat may be unequally developed, and that the resistance thus being modified in places, there may be produced disturbances of the flow which may rapidly produce in part a transverse electromotive force.

Effect, Hall, Real — — A transverse electromotive force produced in conductors conveying electric currents, by magnetic whirls, in a manner similar to that in which the Faraday effect is produced. (See *Effect, Faraday*.)

Effect, Hall, Spurious — — An apparent transverse electromotive force produced in conductors conveying electric currents in magnetic fields, by changes, produced by magnetism, in the conductivity of the metals, and the consequent production of local disturbances in the electrical flow, thus resulting in an apparent transverse electromotive force.

Effect, Impulsion — — The restoration or loss of sensitiveness of a photo-voltaic cell to the action of light, produced by means of an impulse such as that of a tap or blow, or electro-magnetic impulse.

Effect, Joule — —The heating effect produced by the passage of an electric current through a conductor, arising merely from the resistance of the conductor.

The rate at which this occurs is proportional to the *resistance of the conductor* through which the current is passing multiplied by the *square of the current*. (See *Heat, Electric*.)

Effect, Kerr — —A term applied to the electrostatic optical effect discovered by Dr. Kerr, viz., that a beam of plane polarized light is elliptically polarized when transmitted across an electrostatic field.

The Kerr effect does not take place in free space, but occurs in different senses or directions in different media.

Like the Faraday effect, the Kerr effect depends on the presence of a dense medium, and the direction of the effect depends on the character of the medium.

Effect, Mordey — —A term sometimes applied to a decrease in the value of hysteresis in the iron of a dynamo armature at full load.

Effect, Peltier — —The heating effect produced by the passage of an electric current across a thermo-electric junction or surface of contact between two different metals. (See *Junction, Thermo-Electric*.)

The passage of the current across a thermo-electric junction produces either heat or cold. If *heat* is produced by its passage in *one direction*, *cold* is produced by its passage in the *opposite direction*. The Peltier effect may, therefore, mask the Joule effect.

The Peltier effect is the converse of the *thermo-electric effect*, where the unequal heating of metallic junctions results in an electric current. (See *Effect, Joule. Effect, Thomson*.)

The quantity of heat absorbed or emitted by the Peltier effect is proportional to the current strength, and not, as in the Joule effect, to the square of the current.

Effect, Photo-Voltaic — —The change in the resistance of selenium or other substances effected by their exposure to light. The photo-voltaic effect is seen in the case of the selenium cell. (See *Cell, Selenium*.)

Effect, Seebeck — —A term sometimes used instead of thermo-electric effect. (See *Effect, Thermo-Electric*.)

This term has nearly passed out of use.

Effect, Skin — —The tendency of alternating currents to avoid the central portions of solid conductors and to flow or pass mostly through the superficial portions.

The so-called skin effect is more pronounced the more frequent the alternations.

Effect, Thermo-Electric — —The production of an electromotive force at a thermo-electric junction by a difference of temperature between that junction and the other junction of the thermo-electric couple. (See *Couple, Thermo-Electric. Junction, Thermo-Electric*.)

Effect, Thomson — —The production of an electromotive force in unequally heated homogeneous conducting substances.

A term also applied to the increase or decrease in the differences of temperature in an unequally heated conductor, produced by the passage of an electrical current through the conductor.

The Thomson effects vary according to whether the current passes from a colder to a hotter part of the conductor, or the reverse.

The Thomson effects differ in direction in different metals, and are absent in lead. Thomson has pointed out the similarity between this species of thermo-electric phenomena, and *convection by heat*, or the phenomena of a liquid circulating in a closed rectangular tube, under the influence of differences of temperature, *in which the heated fluid gives out heat in the cooler parts of the circuit, and takes in heat in the warmer parts*. This would presuppose that positive electricity carries heat in copper like a real fluid, but that in iron it acts as though its specific heat were a negative quantity, in which respect it is unlike a true fluid.

“We may express,” says Maxwell, “both the Peltier and the Thomson effects by stating that when an electric current is flowing from places of smaller to places of greater thermo-electric power, heat is absorbed, and when it is flowing in the reverse direction heat is generated, and this whether the difference of thermo-electric power in the two places arises from a difference in the

nature of the metals, or from a difference of temperature in the same metal."

Effect, Voltaic — —A difference of potential observed at the point of contact of two dissimilar metals.

This difference of potential was formerly ascribed to the mere contact of dissimilar metals, and is even yet believed by some to be due to such contact. It is, however, perhaps more accurately ascribed to the greater affinity of oxygen of the air for the positive metal than for the negative metal; that is, to a chemical action on the positive element of a voltaic couple.

Effective Electromotive Force.—(See *Force, Electromotive, Effective.*)

Effective Secondary Electromotive Force.—(See *Force, Electromotive, Secondary, Effective.*)

Effects of Capillarity on Voltaic Cells.—(See *Capillarity, Effects of, on Voltaic Cell.*)

Efficiency, Commercial — —The useful or available energy produced divided by the total energy absorbed by any machine or apparatus.

The Commercial Efficiency =

$$\frac{W}{M} = \frac{W}{W + w + m},$$

when W = the useful or available energy; M = the total energy; w , the energy absorbed by the machine, and m , the stray power, or power lost in friction of bearings, etc., air friction, eddy currents, etc.

Efficiency, Commercial, of Dynamo — —The useful or available electrical energy in the external circuit, divided by the total mechanical energy required to drive the dynamo that produced it. (See *Co-efficient, Economic, of a Dynamo-Electric Machine.*)

Efficiency, Electric — —The useful or available electrical energy of any source, divided by the total electrical energy.

The electric efficiency = $\frac{W}{W + w}$, where W , equals the useful or available electrical energy, and w , the electrical energy absorbed by the machine.

Efficiency of Conversion.—The ratio between the energy present in any result and the energy expended in producing that result.

Efficiency of Conversion of Dynamo.—(See *Conversion, Efficiency of, of Dynamo.*)

Efficiency of Transformer.—(See *Transformer, Efficiency of.*)

Efficiency, Quantity, of Storage Battery — —The ratio of the number of ampère-hours taken out of a storage or secondary battery, to the number of ampère-hours put in the battery in charging it.

Efficiency, Real, of Storage Battery — —The ratio of the number of watt-hours taken out of a storage battery, to the number of watt-hours put into the battery in charging it.

Efflorescence.—The drying of crystals by losing their water of crystallization and becoming pulverulent or crumbling.

The term is sometimes loosely applied to the deposition of solid matter by the crystallization of a salt, above the line of the liquid, on the surface of a vessel containing a vaporizable saline solution.

The liquid, by capillarity in a porous vessel, or by adhesion to the walls of an impervious vessel, rises above the level of the main liquid line, and, evaporating, deposits crystals on the vessel.

This process is technically called *creeping*, and is often the cause of much annoyance in voltaic cells.

Egg, Philosopher's — —A name given to the ovoidal, or egg-shaped mass of light that appears when a convective discharge is taken between two electrodes in a partial vacuum.

The philosopher's egg is but one of the shapes assumed by the *convective discharge*. (See *Discharge, Convective.*)

Elasticity, Electric — —The quotient arising from dividing the electric stress by the electric strain.

It can be shown mathematically that the electric elasticity is equal to 4, or 4×3.1416 , divided by the specific inductive capacity.

Electrepeter.—An instrument for changing the direction of an electric current.

The old term for switch, key, or pole changer. (*Obsolete.*)

Electric.—Pertaining to electricity.

Electric Absorption.—(See *Absorption, Electric.*)

Electric Acoutemeter.—(See *Acoutemeter, Electric.*)

Electric Actinometer.—(See *Actinometer, Electric.*)

Electric Adhesion.—(See *Adhesion, Electric.*)

Electric Aging of Alcohol.—(See *Alcohol, Electric Aging of.*)

Electric Alarm.—(See *Alarm, Electric.*)

Electric Alarm Speaking-Tube Mouth-Piece.—(See *Speaking-Tube Mouth-Piece, Electric Alarm.*)

Electric Amalgam.—(See *Amalgam, Electric.*)

Electric Ammunition Hoist.—(See *Hoist, Ammunition, Electric.*)

Electric Analysis.—(See *Analysis, Electric.*)

Electric Analyzer.—(See *Analyzer, Electric.*)

Electric Anemometer.—(See *Anemometer, Electric.*)

Electric Annealing.—(See *Annealing, Electric.*)

Electric Annunciator Clock.—(See *Clock, Electric Annunciator.*)

Electric Arc.—(See *Arc, Electric.*)

Electric Arc Blow-Pipe.—(See *Blow-Pipe, Electric Arc.*)

Electric Argand Burner, Hand-Lighter — —(See *Burner, Argand Electric, Hand-Lighter.*)

Electric Argand Burner, Plain-Pendant — —(See *Burner, Argand Electric, Plain-Pendant.*)

Electric Argand Burner, Ratchet-Pendant — —(See *Burner, Argand Electric, Ratchet-Pendant.*)

Electric Balance.—(See *Balance, Electric.*)

Electric Balloon.—(See *Balloon, Electric.*)

Electric Battery.—(See *Battery, Electric.*)

Electric Bell, Continuous-Sounding — —(See *Bell, Continuous-Sounding Electric.*)

Electric Bell, Differential.—(See *Bell, Differential Electric.*)

Electric Bell, Mechanical.—(See *Bell, Electro-Mechanical.*)

Electric Bell Pull.—(See *Pull, Bell, Electric.*)

Electric Bioscopy.—(See *Bioscopy, Electric.*)

Electric Bi-Polar Bath.—(See *Bath, Bi-Polar.*)

Electric Blasting.—(See *Blasting, Electric.*)

Electric Bleaching.—(See *Bleaching, Electric.*)

Electric Blow-Pipe.—(See *Blow-Pipe, Electric.*)

Electric Boat.—(See *Boat, Electric.*)

Electric Bobbin.—(See *Bobbin, Electric.*)

Electric Body-Protector.—(See *Body-Protector, Electric.*)

Electric Boiler-Feed.—(See *Boiler-Feed, Electric.*)

Electric Branding.—(See *Branding, Electric.*)

Electric Breeze.—(See *Breeze, Electric.*)

Electric Bridge.—(See *Bridge, Electric.*)

Electric Buoy.—(See *Buoy, Electric.*)

Electric Burner.—(See *Burner, Automatic Electric.*)

Electric Buzzer.—(See *Buzzer, Electric.*)

Electric Cable.—(See *Cable, Electric.*)

Electric Calamine.—(See *Calamine, Electric.*)

Electric Call-Bell.—(See *Bell, Call.*)

Electric Calorimeter.—(See *Calorimeter, Electric.*)

Electric Candle.—(See *Candle, Electric.*)

Electric Case-Hardening.—(See *Case-Hardening, Electric.*)

Electric Cauterization.—(See *Cauterization, Electric.*)

Electric Cauterizer.—(See *Cauterizer, Electric.*)

Electric Caутery.—(See *Cautery, Electric.*)

Electric Charge.—(See *Charge, Electric.*)

Electric Chimes.—(See *Chimes, Electric.*)

Electric Chronograph.—(See *Chronograph, Electric.*)

Electric Chronoscope.—(See *Chronoscope, Electric.*)

Electric Cigar-Lighter.—(See *Lighter, Cigar, Electric.*)

Electric Circuit.—(See *Circuit, Electric.*)

Electric Cleats.—(See *Cleats, Electric.*)

Electric Clepsydra.—(See *Clepsydra, Electric.*)

Electric Clock.—(See *Clock, Electric.*)

Electric Coil.—(See *Coil, Electric.*)

Electric Column.—(See *Column, Electric.*)

Electric Communicator.—(See *Communicator, Electric.*)

Electric Conducting.—(See *Conducting, Electrical.*)

Electric Conduction.—(See *Conduction, Electric.*)

Electric Convection of Heat.—(See *Heat, Electric Convection of.*)

Electric Cord.—(See *Cord, Electric.*)

Electric Counter.—(See *Counter, Electric.*)

Electric Creeping.—(See *Creeping, Electric.*)

Electric Cross.—(See *Cross, Electric.*)

Electric Crucible.—(See *Crucible, Electric.*)

Electric Current.—(See *Current, Electric.*)

Electric Cystoscopy.—(See *Cystoscopy, Electric.*)

Electric Damping.—(See *Damping, Electric.*)

Electric Death.—(See *Death, Electric.*)

Electric Decomposition.—(See *Decomposition, Electric.*)

Electric Density.—(See *Density, Electric.*)

Electric Deposition.—(See *Deposition, Electric.*)

Electric Determination of Longitude.—(See *Longitude, Electric Determination of.*)

Electric Displacement.—(See *Displacement, Electric.*)

Electric Distillation.—(See *Distillation, Electric.*)

Electric Door-Bell Pull.—(See *Pull, Electric Door-Bell.*)

Electric Double-Refraction.—(See *Double-Refraction, Electric.*)

Electric Dyeing.—(See *Dyeing, Electric.*)

Electric Dynamometer, Siemens'.—(See *Dynamometer, Electro.*)

Electric Eel.—(See *Eel, Electric.*)

Electric Efficiency.—(See *Efficiency, Electric.*)

Electric Elasticity.—(See *Elasticity, Electric.*)

Electric Elevator.—(See *Elevator, Electric.*)

Electric Endosmose.—(See *Endosmose, Electric.*)

Electric Energy.—(See *Energy, Electric.*)

Electric Entropy.—(See *Entropy, Electric.*)

Electric Escape.—(See *Escape, Electric.*)

Electric Etching.—(See *Etching, Electro.*)

Electric Evaporation.—(See *Evaporation, Electric.*)

Electric Excitability of Nerve or Muscular Fibre.—(See *Excitability, Electric, of Nerve or Muscular Fibre.*)

Electric Exhaustion.—(See *Exhaustion, Electric.*)

Electric Expansion.—(See *Expansion, Electric.*)

Electric Exploder.—(See *Exploder, Electric Mine.*)

- Electric Explorer.**—(See *Explorer, Electric*.)
- Electric Field.**—(See *Field, Electric*.)
- Electric Figures, Breath** — —(See *Figures, Electric, Breath*.)
- Electric Figures, Lichtenberg's** — —(See *Figures, Electric, Lichtenberg's*.)
- Electric Fishes.**—(See *Fishes, Electric*.)
- Electric Fly.**—(See *Fly, Electric*.)
- Electric Flyer.**—(See *Flyer, Electric*.)
- Electric Fog.**—(See *Fog, Electric*.)
- Electric Force.**—(See *Force, Electric*.)
- Electric Furnace.**—(See *Furnace, Electric*.)
- Electric Fuse.**—(See *Fuse, Electric*.)
- Electric Gas-Lighting.**—(See *Gas-Lighting, Electric*.)
- Electric Gas-Lighting, Multiple** — —(See *Gas-Lighting, Multiple Electric*.)
- Electric Gas-Lighting Torch.**—(See *Torch, Electric Gas-Lighting*.)
- Electric Gastroscope.**—(See *Gastroscope, Electric*.)
- Electric Gilding.**—(See *Gilding, Electric*.)
- Electric Governor.**—(See *Governor, Electric*.)
- Electric Hand-Lighter for Argand Burner.**—(See *Burner, Argand Electric Hand-Lighter*.)
- Electric Head-Bath.**—(See *Bath, Head, Electric*.)
- Electric Head-Light.**—(See *Head-Light, Locomotive, Electric*.)
- Electric Heat.**—(See *Heat, Electric*.)
- Electric Heater.**—(See *Heater, Electric*.)
- Electric Horse Power.**—(See *Power, Horse, Electric*.)
- Electric Hydrotasimeter.**—(See *Hydrotasimeter, Electric*.)
- Electric Ignition.**—(See *Ignition, Electric*.)
- Electric Images.**—(See *Images, Electric*.)
- Electric Incandescence.**—(See *Incandescence, Electric*.)
- Electric Indicator for Steamships.**—(See *Indicator, Electric, for Steamships*.)
- Electric Indicators.**—(See *Indicators, Electric*.)
- Electric Inertia.**—(See *Inertia, Electric*.)
- Electric Insolation.**—(See *Insolation, Electric*.)
- Electric Installation.**—(See *Installation, Electric*.)
- Electric Insulation.**—(See *Insulation, Electric*.)
- Electric Irritability.**—(See *Irritability, Electric*.)
- Electric Jar.**—(See *Jar, Electric*.)
- Electric Jewelry.**—(See *Jewelry, Electric*.)
- Electric Lamp, Arc** — —(See *Lamp, Electric, Arc*.)
- Electric Lamp-Bracket.**—(See *Bracket, Lamp, Electric*.)
- Electric Lamp, Incandescent** — —(See *Lamp, Electric, Incandescent*.)
- Electric Lamp, Semi-Incandescent** — —(See *Lamp, Electric, Semi-Incandescent*.)
- Electric Lamp, Socket for.**—(See *Socket, Electric Lamp*.)
- Electric Launch.**—(See *Launch, Electric*.)
- Electric Letter-Box.**—(See *Letter-Box, Electric*.)
- Electric Light.**—(See *Light, Electric*.)
- Electric Lighting, Central Station** — —(See *Station, Central*.)
- Electric Lighting, Isolated** — —(See *Lighting, Electric, Isolated*.)
- Electric Light or Power Cable.**—(See *Cable, Electric Light or Power*.)
- Electric Lock.**—(See *Lock, Electric*.)
- Electric Locomotive.**—(See *Locomotive, Electric*.)
- Electric Log.**—(See *Log, Electric*.)
- Electric Loom.**—(See *Loom, Electric*.)
- Electric Loop.**—(See *Loop, Electric*.)
- Electric Machine, Frictional** — —(See *Machine, Frictional Electric*.)

- Electric Main.**—(See *Main, Electric*.)
- Electric Masses.**—(See *Masses, Electric*.)
- Electric Measurements.**—(See *Measurements, Electric*.)
- Electric Megaloscope.**—(See *Megaloscope, Electric*.)
- Electric Meter.**—(See *Meter, Electric*.)
- Electric Mine-Exploider.**—(See *Mine-Exploider, Electro-Magnetic. Fuse, Electric*.)
- Electric Motor.**—(See *Motor, Electric*.)
- Electric Motor, High-Speed** — — (See *Motor, Electric, High-Speed*.)
- Electric Motor, Low-Speed** — — (See *Motor, Electric, Low-Speed*.)
- Electric Multipolar Bath** — — (See *Bath, Multipolar, Electric*.)
- Electric Musket.**—(See *Musket, Electric*.)
- Electric Organ.**—(See *Organ, Electric*.)
- Electric Oscillations.**—(See *Oscillations, Electric*.)
- Electric Osmose.**—(See *Osmose, Electric*.)
- Electric Osteotome.**—(See *Osteotome, Electric*.)
- Electric Overtones.**—(See *Overtones, Electric*.)
- Electric Pen.**—(See *Pen, Electric*.)
- Electric Pendant.**—(See *Pendant, Electric*.)
- Electric Pendant-Lamps.**—(See *Lamps, Electric Pendant*.)
- Electric Pendulum.**—(See *Pendulum, Electric*.)
- Electric Permeancy.**—(See *Permeancy, Electric*.)
- Electric Phosphorescence.**—(See *Phosphorescence, Electric*.)
- Electric Photometer.**—(See *Photometer*.)
- Electric Piano.**—(See *Piano, Electric*.)
- Electric Plow.**—(See *Plow, Electric*.)
- Electric Position-Finder.**—(See *Finder, Position, Electric*.)
- Electric Potential.**—(See *Potential, Electric*.)
- Electric Power.**—(See *Power, Electric*.)
- Electric Probe.**—(See *Probe, Electric*.)
- Electric Prostration.**—(See *Prostration, Electric*.)
- Electric Protection.**—(See *Protection, Electric, of Houses, Ships and Buildings*.)
- Electric Protection of Metals.**—(See *Metals, Electrical Protection of*.)
- Electric Pulse.**—(See *Pulse, Electrical*.)
- Electric Pyrometer, Siemens'.**—(See *Pyrometer, Siemens', Electric*.)
- Electric Radiometer, Crookes' — —**
(See *Radiometer, Electric, Crookes'*.)
- Electric Range-Finder.**—(See *Finder, Range, Electric*.)
- Electric Ratchet-Pendant for Argand Burner.**—(See *Burner, Argand Electric, Ratchet-Pendant*.)
- Electric Ray.**—(See *Ray, Electric*.)
- Electric Reaction Wheel.**—(See *Wheel, Reaction, Electric*.)
- Electric Rectification of Alcohol.**—(See *Alcohol, Electric Rectification of*.)
- Electric Refining of Metals.**—(See *Metals, Electric Refining of*.)
- Electric Register, Watchman's — —**
(See *Register, Watchman's Electric*.)
- Electric Registering Apparatus.**—(See *Apparatus, Registering, Electric*.)
- Electric Relay-Bell.**—(See *Bell, Relay, Electric*.)
- Electric Repulsion.**—(See *Repulsion, Electric*.)
- Electric Resistance.**—(See *Resistance, Electric*.)
- Electric Resonance.**—(See *Resonance, Electric*.)
- Electric Retardation.**—(See *Retardation, Electric*.)
- Electric Rings.**—(See *Rings, Electric*.)
- Electric Safety Lamps.**—(See *Lamp, Electric Safety*.)
- Electric Saw.**—(See *Saw, Electric*.)

- Electric Seismograph.**—(See *Seismograph, Electric.*)
- Electric Shadow.**—(See *Shadow, Electric.*)
- Electric Shock.**—(See *Shock, Electric.*)
- Electric Shower Bath.**—(See *Bath, Shower, Electric.*)
- Electric Shunt Bell.**—(See *Bell, Shunt, Electric.*)
- Electric Single-Stroke Bell.**—(See *Bell, Single-Stroke, Electric.*)
- Electric Siphon.**—(See *Siphon, Electric.*)
- Electric Soldering.**—(See *Soldering, Electric.*)
- Electric Sphygmograph.**—(See *Sphygmograph, Electrical.*)
- Electric Sterilization.**—(See *Sterilization, Electric.*)
- Electric Storm.**—(See *Storm, Electric.*)
- Electric Striæ.**—(See *Striæ, Electric.*)
- Electric Submarine Boat.**—(See *Boat, Submarine, Electric.*)
- Electric Sunstroke.**—(See *Sunstroke, Electric.*)
- Electric Surgings.**—(See *Surgings, Electric.*)
- Electric Swaging.**—(See *Swaging, Electric.*)
- Electric Tanning.**—(See *Tanning, Electric.*)
- Electric Target.**—(See *Target, Electric.*)
- Electric Teazer.**—(See *Teazer, Electric Current.*)
- Electric Telehydrobarometer.**—(See *Telehydrobarometer, Electric.*)
- Electric Tell-Tale Signal.**—(See *Signal, Electric Tell-Tale.*)
- Electric Tempering.**—(See *Tempering, Electric.*)
- Electric Tension.**—(See *Tension, Electric.*)
- Electric Thermo-Call.**—(See *Thermo-Call, Electric.*)
- Electric Thermometer.**—(See *Thermometer, Electric.*)
- Electric Throwback-Indicator.**—(See *Indicator, Electrical Throwback.*)
- Electric Time-Ball.**—(See *Ball, Electric Time.*)
- Electric Time-Meter.**—(See *Meter, Electric Time.*)
- Electric Torpedo.**—(See *Torpedo, Electric.*)
- Electric Tower.**—(See *Tower, Electric.*)
- Electric Tramway.**—(See *Tramway, Electric.*)
- Electric Transmitters.**—(See *Transmitter, Electric.*)
- Electric Trumpet.**—(See *Trumpet, Electric.*)
- Electric Turn-Table.**—(See *Turn-Table, Electric.*)
- Electric Typewriter.**—(See *Typewriter, Electric.*)
- Electric Valve.**—(See *Valve, Electric.*)
- Electric Valve Burner, Argand** — — (See *Valve Burner, Argand Electric.*)
- Electric Varnish.**—(See *Varnish, Electric.*)
- Electric Vibrating Burner.**—(See *Burner, Vibrating, Electric.*)
- Electric Volatilization.**—(See *Volatilization, Electric.*)
- Electric Water or Liquid Level Alarm.**—(See *Alarm, Water or Liquid Level.*)
- Electric Welding.**—(See *Welding, Electric.*)
- Electric Whirl.**—(See *Whirl, Electric.*)
- Electric Whistle, Automatic Steam** — — (See *Whistle, Steam, Automatic Electric.*)
- Electric Wood Mouldings.**—(See *Mouldings, Electric Wood.*)
- Electric Work.**—(See *Work, Electric.*)
- Electrical Controlling Clock.**—(See *Clock, Electrical Controlling.*)
- Electrically.**—In an electrical manner.
- Electrically Controlled Clock.**—(See *Clock, Electrically Controlled.*)

Electrically Discharge, To — —(See *Discharge, To Electrically.*)

Electrically Discharging.—(See *Discharging, Electrically.*)

Electrically Energizing.—(See *Energizing, Electrically.*)

Electrically Operated Alarm.—(See *Alarm, Electrically Operated.*)

Electrically Retarding.—(See *Retarding, Electrically.*)

Electrician.—One versed in the principles and applications of electrical science.

Electrician, Electro-Therapeutical — —A medical electrician.

Electrician, Medical — —One skilled in the application of electricity to the human body for diagnosis or curative purposes.

A medical electrician should possess a full knowledge, not only of the principles and applications of electric science, but also of physics and chemistry and of the medical sciences.

Electricity.—The name given to the unknown thing, matter or force, or both, which is the cause of electric phenomena.

Electricity, no matter how produced, is believed to be one and the same thing.

The terms *frictional-electricity, pyro-electricity, magneto-electricity, voltaic or galvanic electricity, thermo-electricity, contact-electricity, animal or vegetable-electricity*, etc., etc., though convenient for distinguishing their origin, have no longer the significance formerly attributed to them as representing different kinds of the electric force. (See *Electricity, Single-Fluid Hypothesis of.*)

Electricity, Accumulated — —Electricity collected in or by means of accumulators.

Electricity, Accumulating — —Obtaining successively increasing electrical charges. (See *Electricity, Accumulation of.*)

Electricity, Accumulation of — —A general term applied indifferently to—

(1.) The gradual collecting of electric energy in a Leyden jar or condenser.

(2.) The increase of an electric charge by the action of various devices called accumulators.

(3.) The production of a charge by the use of machines called influence machines.

(4.) The collection of electric energy in the so-called storage batteries or accumulators.

Electricity, Animal — —Electricity produced during life in the bodies of animals.

All animals produce electricity during life. In some, such as the electric eel or torpedo, the amount is comparatively large. In others, it is small.

Some of these animals, when of full size, are able to give very severe shocks, and use this curious power as a means of defense against their enemies.

If the spinal cord of a recently killed frog be brought into contact with the muscles of the thigh, a contraction will ensue.—(*Matteucci.*)

The nerve and muscle of a frog, connected by a water contact with a sufficiently delicate galvanometer, show the presence of a current that may last several hours. Du Bois-Reymond showed that the *ends* of a section of muscular fibres are negative, and their *sides* positive, and has obtained a current by suitably connecting them.

In the opinion of some electro-therapeutists no electric current exists in passive, normal nerve or muscular tissue. In an injured tissue a current, called a *demarcation current*, is produced. (See *Current, Demarcation.*)

All muscular contractions, however, apparently produce electric currents.

In electro-therapeutics, it is probable that greater success would accrue in practice if the human body were regarded as an electric source as well as an electro-receptive device.

Electricity, Atmospheric — —The free electricity almost always present in the atmosphere.

The following facts have been discovered concerning atmospheric electricity, viz.:

(1.) The free electricity of the atmosphere is generally positive, but often changes to negative on the approach of fogs and clouds.

(2.) It exists in greater quantity in the higher regions of the air than near the earth's surface.

(3.) It is stronger when the air is still than when the wind is blowing.

(4.) It is subject to yearly and daily changes in its intensity, being stronger in winter than in summer, and at the middle of the day than either at the beginning or the close.

Electricity, Atmospheric, Origin of —

—The exact cause of the free electricity of the atmosphere is unknown.

Peltier ascribes the cause of the free electricity of the atmosphere to a negatively excited earth, which charges the atmosphere by *induction*. (See *Induction, Electrostatic*.) Free atmospheric electricity has also been ascribed to the evaporation of water; to the condensation of vapor; to the friction of the wind; to the motion of terrestrial objects through the earth's magnetic field; to induction from the sun and other heavenly bodies; to differences of temperature; to combustion, and to gradual oxidation of plant and animal life. It is possible that all these causes may have some effect in producing the free electricity of the atmosphere.

Whatever is the cause of the free electricity of the atmosphere, there can be but little doubt that it is to the condensation of aqueous vapor that the high *difference of potential* of the lightning flash is due. (See *Potential, Difference of*.) As the clouds move through the air they collect the free electricity on the surfaces of the minute drops of water of which they are composed, and when many thousands of these subsequently collect in larger drops the difference of potential is enormously increased in consequence of the equally enormous decrease in the surface of any single drop over the sum of the surfaces of the drops that have coalesced to form it.

Electricity, Atom of — A quantity of electricity equal in amount to that possessed by any chemical monad atom.

Professor Lodge points out the fact that the charge of a monad atom of any element is the smallest charge a body can possess, and is possibly as indivisible as the atom itself. He points out the fact that chemical affinity or atomic attraction may be due to the electrical attraction of atoms containing unlike charges; that although the difference of potential between the atoms is small, probably somewhere between 1 and 3 volts, the distances separating them are so very small that their mutual attractive force must be almost infinitely great.

As D'Auria has pointed out, if the centres of attraction of the atoms be the centres of the atoms themselves, then the atoms, if approached to actual contact, would be separated from one another by a distance equal to half the sum of their diameters. If, however, the centre of at-

traction be situated at any point on the surface of the atoms the distance of separation would become equal to zero, calling d , the distance between them, m and m^1 , their respective masses, and S , a co-efficient varying with the substance, and f , the force of mutual attraction, then :

$$f = S \left(\frac{m m^1}{d^2} \right)$$

from which we see that the value of f_1 becomes infinite when the atoms are in contact.

Electricity, Cal — —Electricity produced by changes of temperature in the core of a transformer.

The changes of temperature in the transformer core can produce a difference of potential in the secondary circuit which increases the electromotive force induced in the secondary by the variations in the primary. This is sometimes called the Acheson effect. (See *Effect, Acheson*.)

Electricity, Conservation of — —A term proposed by Lippman to express the fact that when a body receives an electric charge in the open air, the earth and heavenly bodies receive an equal and opposite charge, thus preserving the sum of the total positive and negative electricities in the universe.

Electricity, Contact — —Electricity produced by the mere contact of dissimilar metals.

The mere contact of two dissimilar metals results in the production of opposite electrical charges on their opposed surfaces, or in a difference of electric potential between these surfaces. The cause of this difference of potential is now very generally ascribed to the voltaic couple being surrounded by the atmosphere, the oxygen of which acts more energetically on the positive element than it does on the negative element.

The mere contact of dissimilar metals cannot produce a constant electric current. An electric current possesses kinetic energy. To produce a constant electric current, therefore, energy must be expended.

The voltaic pile through the contact of dissimilar metals produces a difference of potential, yet the cause of the current is to be found in chemical action. (See *Cell, Voltaic*.)

Electricity, Disguised — —Dissimulated electricity. (See *Electricity, Dissimulated or Latent*.)

Electricity, Dissimulated or Latent —

—The condition of an electric charge when placed near an opposite charge, as in a Leyden jar or condenser.

In this case, merely touching one of the charged surfaces will not effect its complete discharge.

Electricity in the condition of a bound charge was formerly called *latent electricity*. This term is now in disuse. Such a charge is now called a *bound charge*. (See *Charge, Bound. Charge, Free.*)

Electricity, Distribution of —

—Various combinations of electric sources, circuits and electro-receptive devices whereby electricity generated by the sources is carried or distributed to more or less distant electro-receptive devices by means of the various circuits connected therewith.

A number of different systems for the distribution of electricity exist. Among the most important are the following, viz.:

- (1.) Direct or continuous-current distribution.
- (2.) Alternating-current distribution.
- (3.) Storage battery or secondary distribution.
- (4.) Distribution by means of condensers.
- (5.) Distribution by means of motor-generators.

Electricity, Distribution of, by Alternating Currents — —A system of electric distribution by the use of alternating currents.

A system of electric distribution in which lamps, motors, or other electro-receptive devices are operated by means of alternating currents that are sent over the line, but which, before passing through said devices, are modified by apparatus called transformers or converters.

Such a system embraces:

- (1.) An alternating-current dynamo-electric machine or battery of machines.
- (2.) A conductor or line wire arranged in a metallic circuit.
- (3.) A number of converters or transformers whose primary coils are placed in the circuit of the line wire.
- (4.) A number of electro-receptive devices placed in the circuit of the secondary coil of the converter. (See *Transformer.*)

Electricity, Distribution of, by Alternating Currents by Means of Condensers —

—A system of alternate current distribution in which condensers are employed to transform current of high potential received from an alternating current dynamo to currents of low potential which are fed to the lamps or other electro-receptive devices.

In the system of McElroy the conversion from high to low potential is obtained by making the primary plates of the condensers charged by the dynamo smaller than the secondary plates, the ratio of the area of the primary plates to that of the secondary plates being made in accordance with the ratio of conversion desired.

Electricity, Distribution of, by Commutating Transformers —

—A system of electrical distribution in which motor-generators are used, but neither the armature nor the field magnets are revolved, a special commutator being employed to change the polarity of the magnetic circuits.

Electricity, Distribution of, by Constant Currents —

—A system for the distribution of electricity by means of direct, *i. e.*, continuous, steady or non-alternating currents, as distinguished from alternating currents.

Distribution by means of direct currents may be effected in a number of ways; the most important are:

- (1.) Distribution with *constant current* or *series-distribution*.
- (2.) Distribution with *constant potential* or *multiple-distribution*.

Strictly speaking, these, as, indeed, all systems, are systems for the distribution of electric energy rather than the distribution of electricity.

In a system of *series-distribution*, the electro-receptive devices are placed in the main line in series, so that the electric current passes successively through each of them. In such a system each device added increases the total resistance of the circuit so that the total resistance is equal to the sum of the separate resistances on the line.

In order, therefore, to maintain the current strength constant, independent of the number of devices added to or removed from the circuit, the electromotive force of the source must increase with each electro-receptive device added, and decrease with each electro-receptive device taken

out. If the number of electro-receptive devices be great, such a circuit is necessarily characterized by a comparatively high electromotive force.

Since the current passes successively through all the electro-receptive devices, an automatic safety device is necessary in order to automatically provide a short circuit of comparatively low resistance past a faulty device, and thus prevent a single faulty device from invalidating the action of all other devices in the circuit.

Arc lamps are usually connected to the line circuit in series.

In a system of *multiple-distribution*, the electro-receptive devices are connected to the main line or leads in *multiple-arc*, or *parallel*, so that each device added *decreases the resistance of the circuit*. In order, therefore, to maintain a proper current through the electro-receptive devices, the mains must be kept at a nearly constant difference of potential. The electro-receptive devices employed in such a system of distribution are generally of high electric resistance, so that the introduction or removal of a few of the electro-receptive devices will not materially alter the resistance of the whole circuit, and will not, therefore, materially affect the remaining lights.

In this system automatic safety devices, operating by the fusion of a readily melted alloy or metal, are provided for the purpose of preventing too powerful currents from passing through any branch connected with the *main conductors* or *leads*. (See *Plug, Fusible*.)

Incandescent lamps are generally connected with the main conductors or leads in *parallel* or *multiple-arc*.

Distribution of incandescent lamps by series connections is sometimes employed. Such lamps are usually of comparatively low resistance, and are provided each with an automatic cut-out, which establishes a short circuit past the lamp on its failure to properly operate.

During the passage of an electric current through any series-distribution circuit, energy is expended in different portions of the circuit, in proportion to the resistance of these parts. In any system, economy of distribution necessitates that the energy expended in the electro-receptive devices must bear as large a proportion as practicable to the energy expended in the source and leads. In series-distribution, this can readily be accomplished even if the resistance of the leads is comparatively high, since the total resistance of the circuit increases with every electro-receptive

device added. Comparatively thin wires can therefore be employed for a very considerable extent of territory covered, without very great loss.

In systems of multiple-distribution, however, this is impossible; for, since every electro-receptive device added decreases the total resistance of the circuit, unless the resistance of the leads is correspondingly decreased the economy becomes smaller, unless the resistance of the leads was originally so low as to be inappreciable when compared with the change of resistance.

In systems of distribution by alternating currents this is avoided by passing a current of but small strength and considerable difference of potential over a line connecting distant points, and converting this current into a current of large strength and small difference of potential at the places where it is required for use.

Electricity, Distribution of, by Continuous Current, by Means of Condensers

—A system of distribution devised by Doubrava, in which a continuous current is conducted to certain points in the line where a device called a "disjuncter" is employed, to reverse it periodically, and the reversed currents so obtained directly used to charge condensers in the circuit of which induction coils are used.

This method of distribution is a variety of distribution by means of constant currents.

The condensers are used to feed incandescent lamps or other electro-receptive devices.

Electricity, Distribution of, by Continuous Current, by Means of Transformers

—A system for the transmission of electric energy by means of continuous or direct currents that are sent over the line to suitably located stations where motor-dynamos are used for transformers.

The dynamo armature is used with two separate circuits, one of a short and coarse wire, and one of a long fine wire. This construction will permit the conversion of a high to a low potential or *vice versa*; or two separate dynamos can be placed on the same shaft and one used as the motor.

It is evident that a motor generator can be constructed to convert continuous currents into alternate, or alternate currents into continuous cur-

rents. In this last case the armature and fixed circuits must be kept separate.

Another form of continuous current conversion is effected by means of the motion of a commutator which effects a rotation of magnetic polarity in a double-wound armature of fine and coarse wire.

Electricity, Distribution of, by Motor Generators — —A system of electric distribution in which a continuous current of high potential, distributed over a main line, is employed at the points where its electric energy is to be utilized for driving a motor, which in turn drives a dynamo, the current of which is used to energize the electro-receptive devices.

This method of distribution is a variety of distribution by means of continuous or direct currents.

In another system of distribution by means of motor generators, the motor and dynamo are combined in one with a double-wound armature, the fine wire coils in which receive the high potential driving current and the coarse wire coils furnish the low potential current used in the distribution circuits.

Electricity, Double Fluid Hypothesis of — —A hypothesis which endeavors to explain the causes of electric phenomena by the assumption of the existence of two different electric fluids.

The double fluid hypothesis assumes:

(1.) That the phenomena of electricity are due to two tenuous and imponderable fluids, the positive and the negative.

(2.) That the particles of the positive fluid repel one another, as do also the particles of the negative fluid; but that the particles of positive fluid attract the particles of the negative and *vice versa*.

(3.) That the two fluids are strongly attracted by matter, and when present in it produce electrification.

(4.) That the two fluids attract one another and unite, thus masking the properties of each.

(5.) That the act of friction separates these fluids, one going to the rubber and the other to the thing rubbed.

Professor Lodge is disposed to favor the double rather than the single fluid hypothesis. He states in support of this belief the following facts, viz.:

(1.) An electric wind or breeze is produced both at the positive and negative terminals of an

electrical machine, and this whether the point be attached directly to these terminals, or whether it be held in the hand of a person near them.

(2.) The well known peculiarities connected with the spark discharge, seen in Wheatstone's experiments on the velocity of electricity.

(3.) An electrostatic strain scarcely affects the volume of the dielectric, thus suggesting or showing a distorting stress, which alters the shape of the substance of the dielectric, but not its size.

(4.) The effects of electrolysis in what he assumes the double procession of the atoms past each other in opposite directions.

(5.) The phenomena of self-induction, or the behavior of a thick wire on an alternating current.

(6.) The apparent absence of momentum in the electric current, or moment of inertia in an electro-magnet so far as tested.

Electricity, Dynamic — —A term sometimes employed for current electricity in contradistinction to static electricity.

Electricity, Franklinic — —A term sometimes employed in electro-therapeutics, for the electricity produced by a frictional or an electrostatic-induction machine. (See *Current, Franklinic*.)

Electricity, Frictional — —Electricity produced by friction.

This term as formerly employed to indicate static charges as distinguished from currents, is gradually falling into disuse, and the frictional electric machines are being generally replaced by continuous-induction machines, like those of Holtz, Töpler-Holtz, or Wimshurst.

The character of the charge produced by friction depends on the nature of the rubber as well as on that of the thing rubbed.

In the following table the substances are so arranged that any one in the list becomes positively electrified when rubbed by any which follows it:

Positive,

Cat's fur.
Polished glass.
Wool.
Cork at ordinary temperatures.
Coarse brown paper.
Cork heated.
White silk.
Black silk.
Shellac.
Rough glass.—(*Forbes*.)

Negative.

It will be seen that the character of the charge produced by friction depends on the character of the surfaces rubbed. This is seen from the foregoing table, where—

(1.) The roughness of the surface, as in the case of glass, produces a difference in the nature of the charge; thus, rough glass is at the bottom of the table, and smooth, polished glass near the top.

(2.) The state of the surface as shown by the color. Black silk rubbed with white silk is negative to it.

(3.) The state of the surface, as varied by the temperature. Hot cork receives a negative charge when rubbed against a piece of cold cork.

Forbes has pointed out that these differences are probably due to the change produced in the ability of the surface to radiate heat or light. A substance or body which radiates the most light or heat is negative. Thus, a hot body radiates more heat than a cold body, and is negative to it. A rough surface is negative to a smooth surface because it radiates more heat than a smooth surface. For the same reason a black surface is negative to a white surface. In this latter case, however, the black surface is the worse radiator of light.

The contact of dissimilar substances has long been considered by some as one of the requisites for the ready production of electricity by friction. In fact, the production of electricity by friction has been ascribed as an effect due to a true contact force at the points of junction of the rubber and the thing rubbed. Others, however, deny the existence of a true contact force of this nature. (See *Force, Contact*.)

Electricity, Galvanic — —A term used by some in place of voltaic electricity. (See *Electricity, Voltaic*.)

The use of the term galvanic electricity would appear to be less logical than the word voltaic, since Volta, and not Galvani, was the first to find out the true origin of the difference of potential produced in the voltaic pile.

Electricity, Hertz's Theory of Electro-Magnetic Radiations or Waves — —A theory, now generally accepted, which regards light as one of the effects of electro-magnetic pulsations or waves.

The recent brilliant researches of Dr. Hertz, of Carlsruhe, show that when an impulsive discharge

is passing through a conductor, ether waves are radiated or propagated in all directions in the space surrounding the conductor, and that these waves are in all respects similar to those of light, except that they are much longer.

The electro-magnetic waves are set up in the luminiferous ether, and move through it with the same velocity as that of light. Moreover, electro-magnetic waves possess the same powers of reflection, refraction, interference, resonance, etc., etc., as are possessed by waves of light. (See *Resonator, Electric*.)

When an alternating or simple faradic current or pulse of electricity is transmitted from one end to the other of a long metallic conductor, the pulses are believed to travel through the universal ether surrounding the conductor rather than through the conductor itself. The velocity of this propagation in free ether is the same as that of light, and, indeed, is identical with that of light itself. In the inter-atomic or inter-molecular ether, whether of conductors, or of dielectrics, the velocity of propagation varies with the nature of the medium.

The waves produced by electric pulses are of much greater length than those of light.

According to Lodge a condenser of the capacity of a micro-farad, if discharged through a coil having the self-induction of 1 ohm, will give rise to waves in the ether 1,200 miles in length, and will possess a rate of oscillation equal to about 157 complete wave-lengths per second.

A common pint Leyden jar discharged through an ordinary discharging rod, will produce a series of waves about 15 to 20 metres in length, and will possess a rate of oscillation equal to about ten million per second.

Lodge calculates that in order to obtain the short waves requisite to influence the retina of the eye, and thus produce light, the circuit in which the electrical oscillations take place must have at least atomic dimensions, and that the phenomena of light may therefore be due to local oscillations or surgings in circuits of atomic dimensions. (See *Light, Maxwell's Electro-Magnetic Theory of*.)

Electricity, Latent — —A term formerly applied to bound electricity.

Electricity, Magneto — —Electricity produced by the motion of magnets past conductors, or of conductors past magnets.

Electricity produced by magneto-electric

induction. (See *Induction, Electro-Dynamic.*)

Electricity, Multiple-Distribution of, by Constant Potential Circuit — —Any system for the distribution of continuous currents of electricity in which the electro-receptive devices are connected to the leads in multiple-arc or parallel. (See *Electricity, Distribution of, by Constant Currents.*)

Electricity, Natural Unit of — —A term sometimes used in place of an atom of electricity.

The natural unit of electricity is an amount equal to the charge possessed by any monad atom of a chemical element.

The natural unit of electricity is equal to the hundred thousand millionth of the ordinary electrostatic unit, or less than a hundred trillionth of a coulomb. (See *Electricity, Atom of.*)

Electricity, Negative — —One of the phases of electrical excitement.

The kind of electric charge produced on resin when rubbed with cotton.

Electricity, Photo — —Electrical differences of potential produced by the action of light.

Electricity, Plant — —Electricity produced in plants during their growth.

Electricity, Positive — —One of the phases of electric excitement.

The kind of electric charge produced on cotton when rubbed against resin.

Electricity, Production of, by Light — —The production of electric differences of potential by the action of light.

Hallwachs has noticed that a clean metallic plate becomes electrified when light falls upon it.

Differences of potential are produced in a selenium cell when its electrodes are unequally illumined. A thermo cell is an illustration of a difference of potential produced by non-luminous radiation.

Electricity, Pyro — —Electricity developed in certain crystalline bodies by unequally heating or cooling them.

Tourmaline, in the crystalline state, possesses this property in a marked degree. When a crystal of tourmaline is heated or cooled, it

acquires opposite electrifications at opposite ends or poles.

In the crystal of tourmaline shown in Fig. 227, the end A, called the *analogous pole*, acquires a positive electrification, and the end B, called the *antilogous pole*, a negative electrification, while the temperature of the crystal is rising. While cooling, the opposite electrifications are produced.

A heated crystal of tourmaline, suspended by a fibre, is attracted or repelled by an electrified body or by a second heated tourmaline, in the same manner as an electrified body.

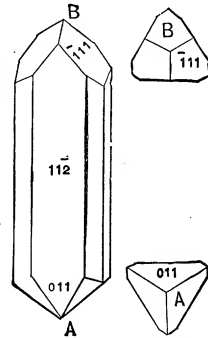

Fig. 227. Pyro Electric Crystal.

Many crystalline bodies possess similar properties. Among these are the ore of zinc known as electric calamine or the silicate of zinc, boracite, quartz, tartrate of potash, sulphate of quinine, etc.

Electricity, Radiation of — —The radiation of electric energy by means of electro-magnetic waves. (See *Electricity, Hertz's Theory of Electro-Magnetic Radiations or Waves.*)

Electricity, Resinous — —A term formerly employed in place of negative electricity.

It was at one time believed that all resinous substances are negatively electrified by friction. This we now know to be untrue, the nature of electrification depending as much on the character of the rubber as on the character of the thing rubbed. Thus resins rubbed with cotton, flannel or silk, become *negatively* excited, but when rubbed with sulphur or gun cotton, *positively* excited. The terms positive and negative are now exclusively employed.

Electricity, Series Distribution of, by Constant Current Circuit — —Any system for the distribution of constant currents of electricity in which the electro-receptive devices are connected to the line-wire or circuit in series. (See *Electricity, Distribution of, by Constant Currents.*)

Electricity, Single-Fluid Hypothesis of — —A hypothesis which endeavors to explain the cause of electrical phenomena by the assumption of the existence of a single electric fluid.

The single-fluid hypothesis assumes:

(1.) That the phenomena of electricity are due to the presence of a single, tenuous, imponderable fluid.

(2.) That the particles of this fluid mutually repel one another, but are attracted by all matter.

(3.) That every substance possesses a definite capacity for holding the assumed electric fluid, and, that when this capacity is just satisfied no effects of electrification are manifest.

(4.) That when the body has less than this quantity present, it becomes *negatively excited*, and when it has more, *positively excited*.

(5.) That the act of friction causes a redistribution of the fluid, part of it going to one of the bodies, giving it a surplus, thus positively electrifying it, and leaving the other with a deficit, thus negatively electrifying it.

The single-fluid hypothesis has been provisionally accepted by some with this modification, that a negatively excited body is thought to be the one which contains the *excess* of the assumed fluid, and a positively excited body the one which contains the *deficit*.

They make this change on account of the phenomena observed in Crookes' tube, where the molecules of the residual gas are observed to be thrown off from the *negative* and not from the positive terminal. (See *Tube, Crookes'*.)

Another view considers electricity to be due to differences of ether pressure, electricity being the ether itself, and electromotive force, the differences of ether pressures. Positive electrification is assumed to result from a surplusage of energy, and negative electrification from a deficit of energy.

At the present time the views of Hertz are generally accepted. (See *Electricity, Hertz's Theory of Electro-Magnetic Radiations or Waves*.)

Electricity, Specific Heat of — —A term proposed by Sir William Thomson to indicate the analogies existing between the absorption and emission of heat in purely thermal phenomena, and the absorption and emission of heat in thermo-electric phenomena. (See *Heat, Specific*.)

As we have already seen heat is either given

out or absorbed, when an electric current passes from one metal to another across a junction between them. (See *Effect, Peltier*.)

So, too, when electricity passes through an unequally heated wire, the current tends to increase or decrease the differences of temperature, according to the direction in which it flows, and according to the character of the metal. (See *Effect, Thomson*.)

"If electricity were a fluid," says Maxwell, "running through the conductor as water does through a tube, and always giving out or absorbing heat till its temperature is that of the conductor, then in passing from hot to cold it would give out heat, and in passing from cold to hot it would absorb heat, and the amount of this heat would depend on the specific heat of the fluid."

Electricity, Static — —A term applied to electricity produced by friction.

The term static electricity is properly employed in the sense of a *static charge* but not as *static electricity*, since that would indicate a particular kind of electricity, and, as is now generally recognized, electricity, from no matter what source it is derived, is one and the same thing.

Electricity, Storage of — —A term improperly employed to indicate such a storage of energy as will enable it to directly reproduce electric energy.

A so-called storage battery does not store electricity, any more than the spring of a clock can be said to store time or sound. The spring stores muscular energy, *i. e.*, renders the muscular kinetic energy potential, which, again becoming kinetic, causes the works of the clock to move or strike.

In the same way in a so-called storage battery, the energy of an electric current is caused to produce electrolytic decompositions of such a nature as independently to produce a current on the removal of the electrolyzing current. (See *Cell, Secondary. Cell, Storage*.)

Electricity, Thermo — —Electricity produced by differences of temperature at the junctions of dissimilar metals.

If a bar of antimony is soldered to a bar of bismuth, and the free ends of the two metals are connected by means of a galvanometer, an application of heat to the junction, so as to raise its

temperature above the rest of the circuit, will produce a difference of potential, which, if neutralized, will cause a current to flow *across* the *junction* from the bismuth to the antimony (against the alphabet, or from B to A). If the junction be cooled below the rest of the circuit, a current is produced across the junction from the antimony to the bismuth (with the alphabet, or from A to B). These currents are called *thermo-electric currents*, and are proportional to the differences of temperature.

Even the same metal, in different physical states or conditions, such as a wire, part of which is straight and the remainder bent into a spiral as at H C, Fig. 228, if heated at F by the flame of

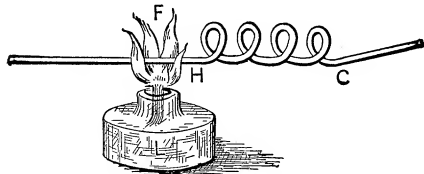

Fig. 228. Thermo-Electricity.

a lamp will have a difference of potential developed in it.

The same thing may also be shown by placing a cylinder of bismuth J, Fig. 229, in a gap in a

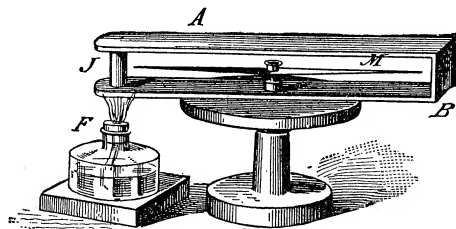

Fig. 229. Thermo-Electric Circuit.

hollow rectangle of copper A B, inside of which a magnetic needle, M, is supported.

The rectangle of copper being placed in the magnetic meridian, on heating the junction by the flame of a lamp F, the needle will be deflected by a current produced by the difference of temperature.

Thermo-electricity is generally obtained by means of the combination of a *thermo-electric couple*, in a *thermo-electric cell*. (See *Couple, Thermo-Electric. Cell, Thermo-Electric.*)

Since the difference of potential produced by a single thermo-electric couple is small, a number of such couples or cells are generally connected in

series to produce a *thermo-electric battery*. (See *Battery, Thermo-Electric.*)

Electricity, Unit Quantity of — —

The quantity of electricity conveyed by unit current per second.

The practical unit quantity of electricity is the *coulomb*, which is the quantity conveyed by a current of one ampère in one second.

Electricity, Unit Quantity of, Natural

— — The quantity of electricity possessed as a charge by any elementary monad atom. (See *Electricity, Atom of.*)

Electricity, Varieties of — —

A classification of electricity according to its state of rest or motion, or to the peculiarities of its motion.

Lodge classifies the different varieties of electricity as follows, viz.:

(1.) Electricity at Rest, or Static Electricity.

This branch of electric science treats of phenomena belonging to stresses and strains in insulated media, when brought into the neighborhood of electric charges, together with the modes of exciting such electric charges, and the laws of their interactions.

(2.) Electricity in Locomotion, or Current Electricity.

This branch of electric science treats of the phenomena produced in metallic conductors, chemical compounds and dielectric media, by the passage of electricity through them, and the modes of exciting electricity into motion, together with the laws of its flow.

(3.) Electricity in Rotation, or Magnetism.

This branch of electric science treats of the phenomena produced in electricity in whirling or vortex motion, the manner in which such whirls may be produced, the strains and stresses which they produce, and the laws of their interactions.

(4.) Electricity in Vibration, or Radiation.

This branch of electric science treats of the study of the propagation of periodic or undulatory disturbances through various kinds of media, the laws regulating wave velocity, wave length, reflection, interference, dispersion, polarization and other similar phenomena generally studied under light.

A misleading classification of electricity is sometimes made according to the sources which produce it. This is misleading, since electricity, no matter how produced, is one and the same.

The so-called varieties of electricity may be divided into different classes according to the nature of the source. The principles of these are as follows:

(1.) Frictional-Electricity, or that produced by the friction of one substance against another.

(2.) Voltaic-Electricity, or that produced by the contact of dissimilar substances under the influence of chemical action.

(3.) Thermo-Electricity, or that produced by differences of temperature in a thermo couple.

(4.) Pyro-Electricity, or that produced by differences of temperature in certain crystalline solids.

(5.) Magneto-Electricity, or that produced by the motion of a conductor through the field of permanent magnets. This is a variety of—

(6.) Dynamo-Electricity, or that produced by moving conductors so as to cut lines of magnetic force.

(7.) Vital-Electricity, or that produced under the influence of life or accompanying life.

Electricity, Vitreous — — A term formerly employed to indicate positive electricity.

It was formerly believed that the friction of glass with other bodies always produces the same kind of electricity. This, however, is now known not to be the case.

The term is now replaced by *positive electricity*. (See *Electricity, Resinous*.)

Electricity, Voltaic — — Differences of potential produced by the agency of a voltaic cell or battery.

Electricity is the same thing or phase of energy by whatever source it is produced.

Electrics.—Substances capable of becoming electrified by friction.

Substances like the metals, which, when held in the hand could not be electrified by friction were formerly called *non-electrics*.

These terms were used by Gilbert in the early history of the science.

This distinction is not now generally employed since conducting substances if insulated, may be electrified by friction.

Electrifiable.—Capable of being endowed with electric properties.

Electrification.—The act of becoming electrified.

The production of an electric charge.

Electrified Body.—(See *Body, Electrified*.)

Electrify.—To endow with electrical properties.

Electrine.—Relating to electrum, or amber.

Electrization, Therapeutical — — Subjecting different parts of the human body to the action of electric currents for the cure of diseased conditions.

Electro-Biology.—(See *Biology, Electro*.)

Electro-Brassing.—(See *Brassing, Electro*.)

Electro-Bronzing.—(See *Bronzing, Electro*.)

Electro - Capillary Phenomena.—(See *Phenomena, Electro-Capillary*.)

Electrocesis.—A word proposed for curing by electricity.

Electro-Chemical Equivalent. — (See *Equivalent, Electro-Chemical*.)

Electro-Chemical Meter.—(See *Meter, Electro-Chemical*.)

Electro-Chemical Telephone.—(See *Telephone, Electro-Chemical*.)

Electro-Chemistry. — (See *Chemistry, Electro*.)

Electro-Chromic Rings.—(See *Rings, Electro-Chromic*.)

Electro-Contact Mine.—(See *Mine, Electro-Contact*.)

Electro-Coppering. — (See *Coppering, Electro*.)

Electro-Crystallization.—(See *Crystallization, Electro*.)

Electrocution.—Capital punishment by means of electricity.

Electrode.—Either of the terminals of an electric source.

The term was applied by Faraday to either of the conductors placed in an electrolytic bath and conveying the current into it, and this is its strict meaning. The terms pole or terminal apply to the ends of a break in any electric circuit.

Electrode, Aural — — A therapeutic electrode, shaped for the treatment of the

ear. (See *Electrode, Electro-Therapeutic.*)

Electrode, Brush — —A therapeutic electrode fashioned like a wire brush or other conducting brush. (See *Electrode, Electro-Therapeutic.*)

Electrode, Caутery-Knife — —A knife-shaped electrode, that is rendered incandescent by the passage of the electric current.

Electrode, Clay — —A therapeutic electrode of clay shaped to fit the part of the body to be treated. (See *Electrode, Electro-Therapeutic.*)

Electrode, Disc — —A disc-shaped electrode employed in electro-therapeutics. (See *Electrode, Electro-Therapeutic.*)

Electrode, Dry — —A therapeutic electrode applied in a dry state. (See *Electrode, Electro-Therapeutic.*)

Electrode, Electro-Therapeutic — — In electro-therapeutics the electrode mainly concerned in the treatment or diagnosis of the diseased parts.

Either the positive or the negative electrode may be the therapeutic electrode, and one or the other is employed according to the particular character of the effect it is desired to obtain. The other electrode is placed at any convenient and suitable part of the body, and is called the *indifferent electrode*.

The therapeutic electrode is generally placed nearer the organ or part to be treated than the indifferent electrode.

Electrode-Handle, Pole-Changing and Interrupting — —A handle provided for the ready insertion of electro-therapeutic electrodes, and provided with means for interrupting or changing the direction of the current.

Electrode, Illumined — —That electrode of a selenium cell which is exposed to the light. (See *Cell, Selenium.*)

Electrode, Indifferent — —In electro-therapeutics the electrode that is employed merely to complete the circuit through the organ or part subjected to the electric cur-

rent, and is not directly concerned in the treatment or diagnosis of the diseased parts.

Either the positive or the negative electrode may be the indifferent electrode. (See *Electrode, Electro-Therapeutic.*)

Electrode, Moist — —A therapeutic electrode applied in a moist condition. (See *Electrode, Electro-Therapeutic.*)

Electrode, Needle — —A therapeutic electrode in the shape of a needle, and employed for electrolytic treatment. (See *Electrode, Electro-Therapeutic.*)

Electrode, Negative — —The electrode connected with the negative pole of an electric source.

Electrode, Non-Illumined — —That electrode of a selenium cell that is protected from the direct action of light. (See *Cell, Selenium.*)

Electrode, Non-Wasting — —A term sometimes applied to the negative electrode of an arc-lamp when made of iridium or other similar material.

Electrode, Positive — —The electrode connected with the positive pole of an electric source.

Electrode, Rectal — —A therapeutic electrode, suitably shaped for the treatment of the rectum. (See *Electrode, Electro-Therapeutic.*)

Electrode, Sponge — —A moistened sponge connected to one of the terminals of an electric source and acting as the electro-therapeutic electrode.

Electrode, Urethral — —An electro-therapeutic electrode suitably shaped for the treatment of the urethra. (See *Electrode, Electro-Therapeutic.*)

Electrode, Vaginal — —An electro-therapeutic electrode suitably shaped for the treatment of the vagina. (See *Electrode, Electro-Therapeutic.*)

Electro-Deposits.—(See *Deposits, Electro.*)

Electrodes.—The terminals of an electric source.

The positive electrode is sometimes called the

Anode, and the negative electrode the *Kathode*. No matter for what purposes employed, they are generally in electro-therapeutics termed electrodes. In precise use these terms should be restricted to the electrodes when used for electrolytic decomposition.

The electrodes are made of different shapes and of different materials according to the character of the work the current is to perform.

Electrodes, Carbon, for Arc-Lamps — —

Rods of artificial carbon employed in arc lamps.

These are more properly called simply arc-lamp carbons.

Arc-lamp carbons are moulded into the shape of rods, from plastic mixtures of carbonaceous materials and carbonizable liquids. On the subsequent carbonization of these rods the ingredients are caused to cohere in one solid mass by the deposit of carbon derived from the carbonizable materials. (See *Carbons, Artificial*.)

Carbons for arc-lamps are generally copper-coated, so as to somewhat decrease their resistance, and insure a more uniform consumption. Arc-lamp carbons are sometimes provided with a central *core* of softer carbon, which fixes the position of the arc and thus insures a steadier light. (See *Carbons, Cored*.)

Electrodes, Cored — — Carbon electrodes of a cylindrical shape provided with a central cylinder of softer carbon.

The use of cored electrodes for arc lamps is for the purpose of steadying the light by maintaining the arc in a central position. This is effected by the greater vaporization of the softer carbon of the core.

Electrodes, Cylindrical Carbon — — Carbon cylinders used for electrodes of arc-lamps, or for battery plates.

Electrodes, Electro-Therapeutic — — Electrodes of various shapes employed in electro-therapeutics.

The electro-therapeutic electrode, as distinguished from the indifferent electrode, is especially shaped for the particular purpose for which it is designed.

When the electricity is intended to affect the skin or superficial portions of the body only, it is applied dry, and is then generally metallic. To reach the deeper structures, such as the muscle or nerve trunks, moistened sponge electrodes are

employed. Before their use the skin should be thoroughly moistened. Sponge-electrodes are generally made conducting by a solution of some saline substance, such as common salt.

Electrodes, Erb's Standard Size of — — Standard sizes of electrodes generally adopted in electro-therapeutics.

The following standard sizes have been proposed by Erb, viz.:

- (1.) Fine electrode.... ½ centimetre diameter.
- (2.) Small " 2 " "
- (3.) Medium " 7.5 " "
- (4.) Large " 6 x 2 " "
- (5.) Very large do.... 8 x 16 " "

Electrodes, Non-Polarizable — — Electrodes employed in electro-therapeutics, that are so constructed as to avoid the effects of polarization.

Non-polarizable electrodes are obtained by employing two amalgamated zinc wires, dipped into saturated solution of zinc chloride placed in glass tubes, and closing the lower ends of the tubes by a piece of potter's clay. The contact of an electrode so prepared with the tissues of the body does not produce a polarization.

Electro-Diagnosis.—(See *Diagnosis, Electro*.)

Electro-Diagnostic.—(See *Diagnostic, Electro*.)

Electro-Dynamic Attraction.—(See *Attraction, Electro-Dynamic*.)

Electro-Dynamic Capacity.—(See *Capacity, Electro-Dynamic*.)

Electro-Dynamic Induction.—(See *Induction, Electro-Dynamic*.)

Electro-Dynamic Repulsion.—(See *Repulsion, Electro-Dynamic*.)

Electro-Dynamics.—(See *Dynamics, Electro*.)

Electro-Dynamometer.—(See *Dynamometer, Electro*.)

Electro-Etching.—Electric etching. (See *Etching, Electro*.)

Electrogenesis.—Results following the application of electricity to the spinal cord or nerve after the withdrawal of the electrodes.

Electro-Gilding.—(See *Gilding, Electro*.)

Electro-Kinetics.—(See *Kinetics, Electro.*)

Electrolifer.—A chandelier for holding electric lamps, as distinguished from a chandelier for holding gas-lights.

Electrology.—That branch of science which treats of electricity. (Obsolete.)

Electrolysis.—Chemical decomposition effected by means of an electric current.

When an electric current is sent through an *electrolyte, i. e.*, a liquid which permits the current to pass only by means of the decomposition of the liquid, the decomposition that ensues is called *electrolytic decomposition*.

The electrolyte is decomposed or broken up into atoms or groups of atoms or *radicals*, called *ions*.

The *ions* are of two distinct kinds, viz.: The *electro-positive ions*, or *kathions*, and the *electro-negative ions*, or *anions*.

Since the *anode* of the source is connected with the electro-positive terminal, it is clear that the *anions*, or the *electro-negative ions*, must appear at the *anode*, and the *kathions*, or *electro-positive ions*, must appear at the *kathode*.

Hydrogen, and the metals generally, are *kathions*. Oxygen, chlorine, iodine, etc., are *anions*.

The vessel containing the electrolyte, in which these decompositions take place, is sometimes called an *electrolytic cell*.

An electrolytic cell is called a *voltmeter* when it is arranged for measuring the current passing by means of the amount of decomposition it effects. (See *Voltmeter*.)

Electrolysis by Means of Alternating Currents.—Electrolytic decomposition effected by means of alternating currents.

When an alternating current is passed through dilute sulphuric acid, in a voltmeter provided with large platinum electrodes, no visible decomposition occurs. If, however, the size of the electrodes be decreased below a certain point, then visible decomposition occurs.

Verdet showed that when no other break exists in the circuit of the alternating current within the voltmeter, no indications of electrolysis are obtained, unless the alternating current is very powerful. If, however, a break is made in the secondary circuit, so that the dis-

charge has to pass as a spark, then visible signs of electrolysis are produced by comparatively feeble alternating currents.

When electrolysis occurs by means of alternating currents—

(1.) The gases collected at both electrodes have the same composition.

(2.) Where the quantities of electricity that alternately pass in opposite directions are unequal, the electrodes show manifest polarization, and, when connected by a conductor, yield a current like a secondary battery.

(3.) The electrodes manifest no sensible polarization where the quantities of electricity that alternately pass in opposite directions are equal.

Electrolysis, Faraday's Laws of — —

The principal facts of electrolysis are given in the following laws:

(1.) The amount of chemical action in any given time is equal in all parts of the circuit.

(2.) The number of *ions* liberated in a given time is proportional to the strength of the current passing. Twice as great a current will liberate twice as many *ions*. The current may be regarded as being carried through the electrolyte by the ions: since an ion is capable of carrying a fixed charge only of + or — electricity, any increase in the current strength necessitates an increase in the number of ions.

(3.) When the same current passes successively through several cells containing different electrolytes, the weights of the *ions* liberated at the different electrodes will be equal to the strength of the current multiplied by the electro-chemical equivalent of the *ion*. (See *Equivalence, Electro-Chemical, Law of*.)

The *chemical equivalent* is proportional to the *atomic weight* divided by the *valency*. (See *Equivalent, Chemical*.)

The electro-chemical equivalent of any element is equal to the weight in grammes of that element set free by one coulomb of electricity, and is found by multiplying the electro-chemical of hydrogen by the chemical equivalent of that element. (See *Equivalent, Electro-Chemical*.)

Electrolyte, Polarization of — —The formation of molecular groups or chains, in which the poles of all the molecules of any chain are turned in the same direction, viz.: with their positive poles facing the negative plate, and their negative poles facing the

positive plate. (See *Cell, Voltaic. Hypothesis, Grotthus'*.)

Electrolytic or Electrolytical.—Pertaining to electrolysis.

Electrolytic Analysis.—(See *Analysis, Electrolytic.*)

Electrolytic Cell.—(See *Cell, Electrolytic, Tesla's.*)

Electrolytic Clock.—(See *Clock, Electrolytic.*)

Electrolytic Conduction.—(See *Conduction, Electrolytic.*)

Electrolytic Convection.—(See *Convection, Electrolytic.*)

Electrolytic Decomposition.—(See *Decomposition, Electrolytic.*)

Electrolytic Hydrogen.—(See *Hydrogen, Electrolytic.*)

Electrolytic Writing.—(See *Writing, Electrolytic.*)

Electrolytically.—In an electrolytic manner.

Electrolyzable.—Capable of being electrolyzed, or decomposed by means of electricity.

Electrolyzed.—Separated or decomposed by means of electricity.

Electrolyzing.—Causing or producing electrolysis.

Electro-Magnet.—(See *Magnet, Electro.*)

Electro-Magnetic Ammeter.—(See *Ammeter, Electro-Magnetic.*)

Electro-Magnetic Annunciator.—(See *Annunciator, Electro-Magnetic.*)

Electro-Magnetic Attraction.—(See *Attraction, Electro-Magnetic.*)

Electro-Magnetic Bell-Call.—(See *Call, Bell, Magneto-Electric.*)

Electro-Magnetic Bell, Siemens' Armature — — (See *Bell, Electro-Magnetic, Siemens' Armature Form.*)

Electro-Magnetic Brake.—(See *Brake, Electro-Magnetic.*)

Electro-Magnetic Cam.—(See *Cam, Electro-Magnetic.*)

Electro-Magnetic Dental-Mallet.—(See *Dental-Mallet, Electro-Magnetic.*)

Electro-Magnetic Drill.—(See *Drill, Electro-Magnetic.*)

Electro-Magnetic Engine.—(See *Engine, Electro-Magnetic.*)

Electro-Magnetic Exploder.—(See *Exploder, Electro-Magnetic.*)

Electro-Magnetic Eye.—(See *Eye, Electro-Magnetic.*)

Electro-Magnetic Impulse.—(See *Impulse, Electro-Magnetic.*)

Electro-Magnetic Induction.—(See *Induction, Electro-Magnetic.*)

Electro-Magnetic Medium.—(See *Medium, Electro-Magnetic.*)

Electro-Magnetic Meter.—(See *Meter, Electro-Magnetic.*)

Electro-Magnetic Momentum of Secondary Circuit.—(See *Momentum, Electro-Magnetic, of Secondary Circuit.*)

Electro-Magnetic Pop-Gun.—(See *Pop-Gun, Electro-Magnetic.*)

Electro-Magnetic Radiation.—(See *Radiation, Electro-Magnetic.*)

Electro-Magnetic Repulsion.—(See *Repulsion, Electro-Magnetic.*)

Electro-Magnetic Resonator.—(See *Resonator, Electro-Magnetic.*)

Electro-Magnetic Shunt.—(See *Shunt, Electro-Magnetic.*)

Electro-Magnetic Solenoid.—(See *Solenoid, Electro-Magnetic.*)

Electro-Magnetic Strain.—(See *Strain, Electro-Magnetic.*)

Electro-Magnetic Stress.—(See *Stress, Electro-Magnetic.*)

Electro-Magnetic Theory of Light, Maxwell's — — (See *Light, Maxwell's Electro-Magnetic Theory of.*)

Electro-Magnetic Vibrator.—(See *Vibrator, Electro-Magnetic.*)

Electro-Magnetic Voltmeter.—(See *Voltmeter, Electro-Magnetic.*)

Electro-Magnetic Units.—(See *Units, Electro-Magnetic.*)

Electro-Magnetics. — (See *Magnetics, Electro.*)

Electro-Massage.—(See *Massage, Electro.*)

Electro-Mechanical Alarm.—(See *Alarm, Electro-Mechanical.*)

Electro-Mechanical Gong.—(See *Gong, Electro-Mechanical.*)

Electro-Metallurgical Crystalline Deposit.—(See *Deposit, Crystalline, Electro-Metallurgical.*)

Electro-Metallurgical Galvanization.—(See *Galvanization, Electro-Metallurgical.*)

Electro-Metallurgical Nodular Deposit.—(See *Deposit, Electro-Metallurgical Nodular.*)

Electro-Metallurgical Reguline Deposit.—(See *Deposit, Electro-Metallurgical Reguline.*)

Electro-Metallurgical Sandy Deposit.—(See *Deposit, Electro-Metallurgical Sandy.*)

Electro-Metallurgy.—(See *Metallurgy, Electro.*)

Electrometer.—An apparatus for measuring differences of potential.

Electrometers operate, in general, by means of the attraction or repulsion of charged conductors on a suitably suspended needle or disc. As no current is required to flow through the apparatus electrometers are especially adapted to many cases where voltmeters could not be so readily used.

Electrometer, Absolute — —An electrometer the dimensions of which are such that the value of the electromotive force can be directly determined from the amount of the deflection of the needle.

A form of attracted-disc electrometer. (See *Electrometer, Attracted-Disc.*)

Electrometer, Attracted-Disc — —A form of electrometer devised by Sir William

Thomson, in which the force is measured by the attraction between the two discs.

Thomson's Attracted-Disc Electrometer is shown in Fig. 230. It consists of a plate C, suspended from the longer end of a lever l, within the fixed guard plate, or guard ring B, immediately above a second plate A, supported on an insulated stand, and capable of a measurable approach

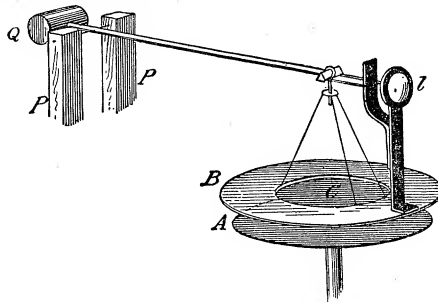

Fig. 230. Attracted-Disc Electrometer.

towards C, or a movement away from it. The plate, C, is placed in contact with B, by means of a thin wire. By means of this connection the distribution of the charge over the plate, C, is uniform. The electrostatic attraction is measured by the attraction of the fixed disc, A, on the movable disc, C, connected respectively to the two bodies whose difference of potential is to be measured. One of these may be the earth. The fulcrum of the lever l, is formed of an aluminium wire, the torsion of which is used to measure the force of the attraction; or, it may be measured directly by the counterpoise weight Q.

This instrument is sometimes called an absolute electrometer, because, knowing the dimensions of the apparatus, the value of the difference of potential can be directly determined from the amount of the motion observed.

Electrometer, Capillary — —An electrometer in which a difference of potential is

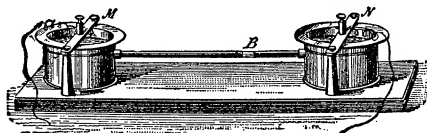

Fig. 231. Capillary Electrometer.

measured by the movement of a drop of sulphuric acid in a tube filled with mercury.

A form of capillary electrometer is shown in Fig. 231, in which a horizontal glass tube with a drop of acid at B, has its ends connected with two vessels M and N, filled with mercury. If a current be passed through the tube, a movement of the drop *towards the negative pole* will be observed. Where the electromotive force does not exceed one volt, the amount of the movement is proportional to the electromotive force.

Electrometer, Quadrant — — An electrometer in which an electrostatic charge is measured by the attractive and repulsive force of four plates or quadrants, on a light needle of aluminium suspended within them.

The sectors or quadrants are of brass, and are so shaped as to form a hollow cylindrical box when placed together. The four sectors, or quadrants, are insulated from one another, but the opposite ones are connected by a conducting wire, as shown in Fig.

232. A light needle of aluminium, u, maintained at some constant potential, by connection with the inner coating of a Leyden jar, is suspended, generally by two parallel silk threads,

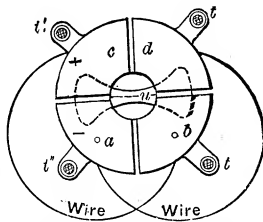

Fig. 232. Quadrant Electrometer.

so as to freely swing inside the hollow box. This needle, when at rest, is in the position shown by the dotted lines, with its axis of symmetry exactly under one of the slots or spaces between two opposite sectors. (See *Suspension, Bi-Filar.*)

The quadrant electrometer, shown in Fig. 233, has one of its quadrants removed so as to show the suspended aluminium needle.

A similar form of instrument is shown in Fig. 234, with all the quadrants in place, and the whole instrument covered by a glass shade.

To use the quadrant electrometer the pairs of sectors are connected with the two bodies whose difference of potential is to be measured, and the deflection of the needle observed, generally through a *telescope*, by means of a spot of light reflected from a mirror attached to the upper part of the needle.

Sometimes the segments are made in the shape of a cylinder, and the needle in the shape of a suspended rectangle.

Electrometer, Registering — — An electrometer, the deviations of the needle of which are automatically registered.

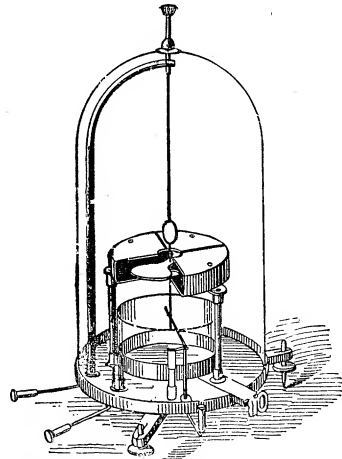

Fig. 233. Quadrant Electrometer, Showing Suspended Needle.

The registration of this class of electrometer is obtained by means of photography. The spot of

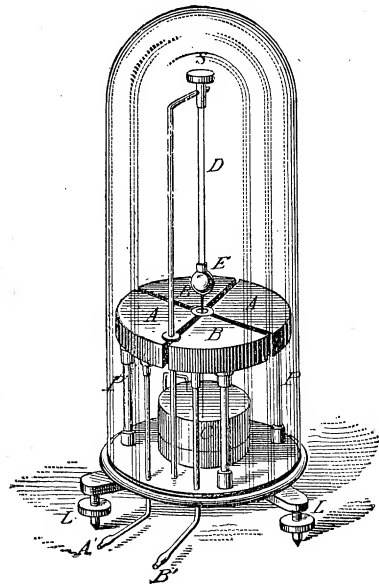

Fig. 234. Quadrant Electrometer.

light, reflected from the mirror of the electrometer, falls on a fillet of sensitized paper, moved by clockwork.

Electromotive Arrangement or Device.—(See *Arrangement or Device, Electromotive.*)

Electromotive Difference of Potential.—(See *Potential, Difference of Electromotive.*)

Electromotive Force.—(See *Force, Electromotive.*)

Electromotive Force, Average — — (See *Force, Electromotive, Average or Mean.*)

Electromotive Force, Back or Counter — — (See *Force, Electromotive, Back.*)

Electromotive Force, Direct — — (See *Force, Electromotive, Direct.*)

Electromotive Force, Inductive — — (See *Force, Electromotive, Inductive.*)

Electromotive Force, Secondary-Im-pressed — — (See *Force, Electromotive, Secondary-Im-pressed.*)

Electromotive Force, Simple-Periodic — — (See *Force, Electromotive, Simple-Periodic.*)

Electromotive Force, Transverse — — (See *Force, Electromotive, Transverse.*)

Electromotive Impulse.—(See *Impulse, Electromotive.*)

Electro-Motograph.—(See *Motograph, Electro.*)

Electro-Muscular.—(See *Muscular, Electro.*)

Electro-Muscular Excitation.—(See *Excitation, Electro-Muscular.*)

Electronecrosis.—Pertaining to capital punishment by means of electricity.

Electronecrosis.—A word proposed for capital punishment by means of electricity.

Electro-Negative Ions.—(See *Ions, Electro-Negative.*)

Electronegatives.—The atoms or radicals that appear at the anode or positive terminal during electrolysis.

The anions. (See *Electrolysis, Anion.*)

Electro-Nervous Excitability.—(See *Excitability, Electro-Nervous.*)

Electro-Nickeling.—(See *Nickeling, Electro.*)

Electro-Optics.—(See *Optics, Electro.*)

Electrophanic.—Pertaining to capital punishment by means of electricity.

Electrophanical.—Pertaining to capital punishment by means of electricity.

Electrophanize.—To inflict capital punishment by means of electricity.

Electrophanity.—Capital punishment by means of electricity.

The word electrophanity would appear to be far preferable to the word electrocution, since it is in accordance with etymological usage, while electrocution is not.

Electrophila.—A devotee of electricity.

Electrophobia.—A word proposed for fear of electricity.

Electrophoric.—Pertaining to an electrophorus. (See *Electrophorus.*)

Electrophorus.—An apparatus for the production of electricity by electrostatic induction. (See *Induction, Electrostatic.*)

A disc of vulcanite, or hard rubber B, contained in a metallic form, is rubbed briskly by a piece of cat's skin and the insulated metallic disc, A, is placed on the centre of the vulcanite disc, as shown in Fig. 235. *Electrophorus, Charging.*

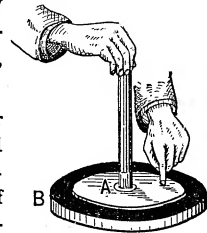

The negative charge produced in B, by friction, produces by induction a positive charge on the part of A, nearest it, and a negative charge on the part furthest from it.

In this condition, if the disc be raised from the plate by means of its insulating handle, as shown in Fig. 236, no electrical effects will be noticed, since the two opposite and equal charges unite and neutralize each other. If, however, the disc A, be first touched by the finger, and then raised from the disc B, it will be found to be positively charged.

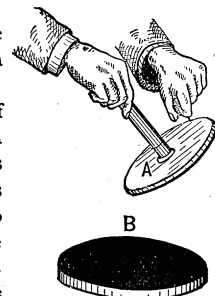

Fig. 236. *Electrophorus, Discharging.*

Electro-Physiology.—(See *Physiology, Electro.*)

Electro-Pneumatic Medium.—(See *Medium, Electro-Pneumatic.*)

Electro-Plating.—(See *Plating, Electro.*)

Electro-Plating Bath.—(See *Bath, Electro-Plating.*)

Electro-Pneumatic Signals.—(See *Signals, Electro-Pneumatic.*)

Electro-Pneumatic Thermostat.—(See *Thermostat, Electro-Pneumatic.*)

Electro-Pneumatic Liquid.—(See *Liquid, Electro-Pneumatic.*)

Electro-Positive Ions.—(See *Ions, Electro-Positive.*)

Electropositives.—The atoms or radicals that appear at the cathode or negative terminal of any source during electrolysis.

The kathions. (See *Electrolysis, Kathion.*)

Electro-Prognosis.—(See *Prognosis, Electric.*)

Electro-Puncture.—(See *Puncture, Electro.*)

Electro-Receptive Devices.—(See *Device, Electro-Receptive.*)

Electro-Receptive Devices, Multiple-Arc-Connected — —(See *Devices, Electro-Receptive, Multiple-Arc-Connected.*)

Electro-Receptive Devices, Multiple-Series-Connected — —(See *Devices, Electro-Receptive, Multiple-Series-Connected.*)

Electro-Receptive Devices, Series-Connected — —(See *Devices, Electro-Receptive, Series-Connected.*)

Electro-Receptive Devices, Series-Multiple-Connected — —(See *Devices, Electro-Receptive, Series-Multiple-Connected.*)

Electroscope.—An apparatus for showing the presence of an electric charge, or for determining its sign, whether positive or negative, but not for measuring its amount or value.

In the gold-leaf electroscope, two gold leaves, n, n, Fig. 239, suspended near each other, show by their repulsion the presence of an electric charge. Two pith balls may be used for the same purpose.

The pith balls B, B, shown in Fig. 237, form a simple electroscope. If repelled by a charge, when approached by a similar charge in S, they will at once be still further repelled, as shown by the dotted lines.

To use an electroscope for determining the *sign* of

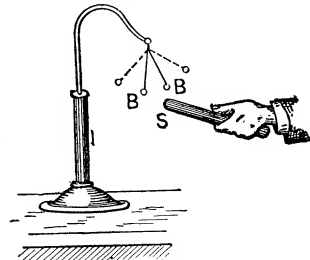

Fig. 237. Pith Ball Electroscope.

an unknown charge, the gold leaves or pith balls are first slightly repelled by a charge of known name, as, for example, positive, applied to the knob C, Fig. 239. They are then charged by the electrified body whose charge is to be determined. If they are further repelled, its charge is positive. If they are first attracted and afterwards repelled, its charge is negative.

Two posts B, Fig. 239, connected with the earth, increase the amount of divergence by induction.

Electroscope, Condensing, Volta's — —
An electroscope employed for the detection of feeble charges, the leaves of which are charged by means of a condenser.

The condensing electroscope, Fig. 238, is formed of two metallic plates, placed at the top of the instrument, and separated by a suitable dielectric. The upper plate, P, is removable by means of the insulated handle, G.

To employ the electroscope, as for example, to detect the free charge in an unequally heated crystal of tourmaline, the crystal is touched to the lower plate, while the upper plate is connected to the ground by the finger. On the subsequent removal of the upper plate an enormous decrease

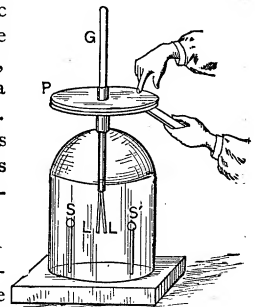

Fig. 238. Condensing Electroscope.

ensues in the capacity of the condenser, and the charge now raises the potential of the lower plate, and causes a marked divergence of the leaves L, L. (See *Electricity, Pyro.*)

Electroscope, Gold-Leaf — — An electroscope in which two leaves of gold are used to detect the presence of an electric charge, or to determine its character whether positive or negative.

When a charge is imparted to the knob C, Fig. 239, the gold leaves n, n, diverge. This will occur whether the charge be positive or negative.

To determine the character of an unknown charge, the leaves are first caused to diverge by means of a known positive or negative charge. The unknown charge is then given to the leaves. If they diverge still further, then the charge is of the *same name* as that originally possessed by the leaves. If, however, they first *move together* and are afterwards repelled, the charge is of the *opposite name*.

Electroscope, Pith - Ball — — An electroscope which shows the presence of a charge by the repulsion of two similarly charged pith balls. (See *Electroscope.*)

Any two pith balls, suspended by conducting threads, but insulated from the earth, will serve as an electroscope.

Electroscope, Quadrant, Henley's — — An electroscope sometimes employed to indicate large charges of electricity.

A pith ball placed on a light arm A, of straw or other similar material, Fig. 240, is pivoted at the centre of a graduated circle B. The arm, C, is attached by means of the screw to the prime conductor of an electric machine. The similar charge imparted to A, by contact

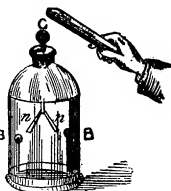

Fig. 239. Gold-Leaf Electroscope.

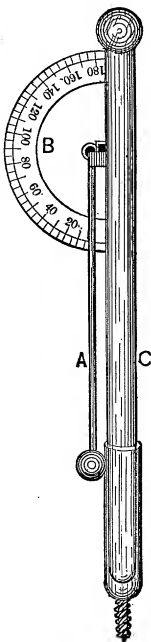

Fig. 240. Henley's Electroscope.

with C, causes a repulsion which may be measured on the graduated arc.

This instrument approaches the electrometer in the character of its operation, since by its means, approximately correct measurements may be made of the value of the repulsion. It should not, however, be confounded with the *quadrant electrometer*. (See *Electrometer, Quadrant.*)

Electroscopically.—By means of the electroscope. (See *Electroscope.*)

Electroscopy.—The art of determining the kind of charge a body possesses, by means of an electroscope.

Electro - Sensibility.—(See *Sensibility, Electro.*)

Electro-Silvering.—(See *Silvering, Electro.*)

Electro-Smelting.—(See *Smelting, Electro.*)

Electrostatic Attraction.—(See *Attraction, Electrostatic.*)

Electrostatic Capacity.—(See *Capacity, Electrostatic.*)

Electrostatic Circuit.—(See *Circuit, Electrostatic.*)

Electrostatic Field.—(See *Field, Electrostatic.*)

Electrostatic Induction.—(See *Induction, Electrostatic.*)

Electrostatic Induction Machine.—(See *Machine, Electrostatic Induction.*)

Electrostatic Leakage.—(See *Leakage, Electrostatic.*)

Electrostatic Lines of Force.—(See *Force, Electrostatic, Lines of.*)

Electrostatic Repulsion.—(See *Repulsion, Electrostatic.*)

Electrostatic Screening.—(See *Screening, Electrostatic.*)

Electrostatic Stress.—(See *Stress, Electrostatic.*)

Electrostatic Units.—(See *Units, Electrostatic.*)

Electrostatics.—That branch of electric science which treats of the phenomena and measurement of electric charges.

The principles of electrostatics are embraced in the following laws, viz.:

(1.) Charges of like name, *i. e.*, either positive or negative, repel each other. Charges of unlike name attract each other.

(2.) The forces of attraction or repulsion between two charged bodies are directly proportional to the product of the quantities of electricity possessed by the bodies and inversely proportional to the square of the distance between them.

These laws can be demonstrated by the use of Coulomb's torsion balance. (See *Balance, Torsion*.)

Calling q , and q^1 , the quantities of electricity possessed by the two bodies, and r , the distance between them, then, if f , is the force exerted by their mutual action,

$$f = \frac{q q^1}{r^2}.$$

Electro-Technics.—(See *Technics, Electro*.)

Electrothanasing.—Producing death by electricity.

Electrothanasis.—A word proposed for death by electricity.

The death referred to here is death other than that caused by capital punishment.

Electrothanasise.—To produce death by electricity.

The death here referred to is other than that caused by capital punishment.

Electrothanasose.—To cause death by electricity.

Electrothanasotic.—Pertaining to capital punishment by means of electricity.

Electrothanasosing.—Causing death by electricity.

Electrothanasosis.—A word proposed for death by electricity.

The death here referred to is death other than that caused by capital punishment.

Electro-Therapeutic Bath.—(See *Bath, Electro-Therapeutic*.)

Electro-Therapeutic Breeze.—(See *Breeze, Electro-Therapeutic*.)

Electro-Therapeutic Diffusion of Current.—(See *Current, Diffusion of, Electro-Therapeutic*.)

Electro-Therapeutic Dosage.—(See *Dosage, Electro-Therapeutic*.)

Electro-Therapeutic Electrode.—(See *Electrode, Electro-Therapeutic*.)

Electro-Therapeutic Electrodes.—(See *Electrode, Electro-Therapeutic*.)

Electro-Therapeutic Galvanization.—(See *Galvanization, Electro-Therapeutic*.)

Electro-Therapeutic Head-Breeze.—(See *Breeze, Head, Electro-Therapeutic*.)

Electro-Therapeutics.—(See *Therapeutics, Electro*.)

Electro-Therapist.—(See *Therapist, Electro*.)

Electro-Therapy.—(See *Therapy, Electro*.)

Electro-Thermal Meter.—(See *Meter, Electro-Thermal*.)

Electro-Tinning.—(See *Tinning, Electro*.)

Electrotisic.—Pertaining to capital punishment by means of electricity.

Electrotising.—Producing capital punishment by means of electricity.

Electrotisis.—A word proposed for capital punishment by means of electricity.

Electrotonic Current.—(See *Current, Electrotonic*.)

Electrotonic Effect.—(See *Effect, Electrotonic*.)

Electrotonic Excitability.—(See *Excitability, Electrotonic*.)

Electrotonic State.—(See *State, Electrotonic*.)

Electrotonus.—A condition of altered functional activity which occurs in a nerve when subjected to the action of an electric current.

The electrotonic state is produced by the passage through a nerve of a constant current called the polarizing current.

Electrotonus is attended by the modification of the nerve in the following respects, viz.:

- (1.) In its electromotive force.
- (2.) In its excitability.

The passage of the constant current produces a change in the electromotive force of that part of the nerve traversed by the current.

This alteration in muscular excitability may consist in either an increased or a decreased functional activity. The *decreased* functional activity occurs in the neighborhood of the anode, or the positive terminal, and is called the *anelectrotonic state*. The *increased* functional activity occurs in the neighborhood of the kathode, or the negative terminal, and is called the *kathoelectrotonic state*. (See *Anelectrotonus*. *Kathoelectrotonus*.)

This altered functional activity affects not only the *intra polar* parts of the nerve, or that part between the electrodes, but also the *extra-polar portions*, or, in other words, the remainder of the nerve.

The electrotonic state is characterized by two varieties, viz.: those in which the electromotive force of the nerve is decreased, and those in which the electromotive force of the nerve is increased. These varieties of electrotonus are called respectively the negative and positive phase of electrotonus. (See *Electrotonus*, *Negative Phase of*. *Electrotonus*, *Positive Phase of*.)

Electrotonus, Negative Phase of — —

A decrease in the electromotive force of a nerve effected by sending a current through the nerve in the opposite direction to the nerve current. (See *Current*, *Nerve*.)

Electrotonus, Positive Phase of — —

An increase in the electromotive force of a nerve effected by sending a current through the nerve in the same direction as the nerve current.

The increase in the electromotive force not only affects the portions of the nerve in the intra-polar regions, but in the extra-polar regions as well.

Electrotype.—A type, cast, or impression of an object obtained by means of electro-metallurgy. (See *Metallurgy*, *Electro. Electrotyping*.)

Electrotyping, or the Electrotype Pro-

cess — —Obtaining casts or copies of objects by depositing metals in molds by the agency of electric currents.

The molds are made of wax, or other plastic substance, rendered conducting by coating it with powdered plumbago.

The mold is connected with the negative battery terminal, and placed in a metallic solution, generally of copper sulphate, opposite a plate of metallic copper, connected with the positive battery terminal. As the current passes, the metal is deposited on the mold at the kathode, and dissolved from the metallic plate at the anode, thus producing an exact copy or cast and at the same time maintaining constant the strength of the bath.

Electrozemia.—A word proposed for capital punishment by means of electricity.

Electrum.—A name given by the ancients to various substances that could be readily electrified by friction.

The term electrum included a number of substances, but was applied mainly either to amber or to an alloy of gold and silver.

Element.—Any kind of matter which cannot be decomposed into simpler matter.

Matter that is formed or composed of but one kind of atoms.

Oxygen and hydrogen are *elements* or varieties of elementary matter. They cannot be decomposed into anything but oxygen or hydrogen. Water, on the contrary, is *compound matter*, since it can be decomposed into its constituent parts, oxygen and hydrogen.

There are about seventy well-known elements, some of which are very rare, occurring in extremely small quantities.

The evidence of the true elementary condition of many of the elements is based, to a great extent, on the fact that so far they have resisted all efforts made to decompose them into simpler substances. We should bear in mind, however, that until Davy's use of the voltaic battery, potash, soda, and many other similar compounds were regarded as true elements. It is not improbable that many of the now so-called elements, may hereafter be decomposed into simpler constituents.

The following table gives the names, chemical

symbols, approximate atomic weights and equivalents of the principal elements :

Names of Elements.	Symbol.	Approximate Atomic Weight.	Chemical Equivalent.*
Aluminium	Al.	27.	9 [compounds
Antimony	Sb.	120.	40 in <i>ous</i> , 24 in <i>ir</i>
Arsenic	As.	74.9	24.9 in <i>ous</i> , 15 in <i>ic</i>
Barium	Ba.	136.8	68.4
Beryllium	Be.	9.1	4.6
Bismuth	Bi.	207.5	69.2
Boron	B.	10.9	3.6
Bromine	Br.	79.8	79.8
Cadmium	Cd.	111.8	55.9
Cæsium	Cs.	132.6	66.3
Calcium	Ca.	40.	20
Carbon	C.	12.	6
Cerium	Ce.	140.4	
Chlorin	Cl.	35.4	35.4
Chromium	Cr.	52.	26 in <i>ous</i> , 17.3 in <i>ic</i>
Cobalt	Co.	58.9	29.5
Copper	Cu.	63.2	31.6
Didymium	D.	144.6	
Erbium	E.	165.9	
Fluorine	F.	19.	19.
Gallium	Ga.	68.9	
Germanium	Ge.	72.3	
Glucium	G.		
Gold	Au.	196.2	196.2 in <i>ous</i> , 65.4 in <i>ic</i>
Hydrogen	H.	1.	1
Indium	In.	113.4	37.8
Iodine	I.	126.6	126.6
Iridium	Ir.	192.7	93.4, 64.2, 48.2
Iron	Fe.	55.9	28 in <i>ous</i> , 18.6 in <i>ic</i>
Lanthanum	La.	138.5	
Lead	Pb.	206.5	103.3
Lithium	Li.	7.	7
Magnesium	Mg.	24.	12
Manganese	Mn.	53.9	27
Mercury	Hg.	199.7	199.7 in <i>ous</i> , 99.9 in <i>ic</i>
Molybdenum	Mo.	95.5	
Nickel	Ni.	57.9	28
Niobium	Nb.	93.8	
Nitrogen	N.	14.	14
Osmium	Os.	198.5	8
Oxygen	O.	16.	8
Palladium	Pd.	105.7	52.9 in <i>ous</i> , 26.4 in <i>ic</i>
Phosphorus	P.	31.	6.2 in phosphates
Platinum	Pt.	194.4	97.2 in <i>ous</i> , 48.6 in <i>ic</i>
Potassium	K.	39.1	39.
Rhodium	R.	104.1	52 in <i>ous</i> , 31.7 in <i>ic</i>
Rubidium	Rb.	85.3	85.3
Ruthenium	Ru.	104.2	52.1 in <i>ous</i> , 34.7 in <i>ic</i>
Samarium	Sm.	150.02	
Scandium	Sc.	44.	
Selenium	Se.	78.8	
Silicon	Si.	28.2	7.
Silver	Ag.	107.7	107.7
Sodium	Na.	23.	23
Strontium	Sr.	87.4	43.7
Sulphur	S.	32.	
Tantalum	Ta.	182.1	
Tellurium	Te.	128.	
Thallium	Tl.	203.7	203.7 in <i>ous</i> , 67.9 in <i>ic</i>
Thorium	Th.	233.4	
Tin	Sn.	117.7	58.9 in <i>ous</i> , 29.4 in <i>ic</i>
Titanium	Ti.	48.	24 in <i>ous</i> , 12 in <i>ic</i>
Tungsten	W.	183.6	91.8 in <i>ous</i>
Uranium	U.	238.5	119.2 in <i>ous</i>
Vanadium	Va.	51.3	17.1 in <i>ous</i>
Ytterbium	Yb.	172.8	
Yttrium	Y.	89.8	
Zinc	Zn.	64.9	32.5
Zirconium	Zr.	89.4	

* Atomic weight divided by the valency.

Element, Negative — — One of the substances forming a voltaic couple. (See *Couple, Voltaic*.)

Element, Negative, of a Voltaic Cell — — That element or plate of a voltaic cell into which the current passes from the exciting fluid of the cell.

The plate that is not acted on by the electrolyte during the generation of current by the cell.

The copper or carbon plate, respectively, in a zinc-copper or zinc-carbon couple.

It must be carefully borne in mind that the conductor attached to the *negative element of a voltaic pile is the positive conductor or electrode of the pile*, since the current that flows into the plate from the liquid or electrolyte must flow out of the plate where it projects beyond the liquid.

Element of Current.—(See *Current, Element of*.)

Element of Storage Battery.—(See *Battery, Storage, Element of*.)

Element, Positive — — That element or plate of a voltaic cell from which the current passes into the exciting fluid of the cell.

The element of a voltaic couple which is acted on by the exciting fluid of the cell. (See *Couple, Voltaic*.)

Element, Thermo-Electric — — One of the two metals or substances which form a thermo-electric couple. (See *Couple, Thermo-Electric*.)

Element, Voltaic — — One of the two metals or substances which form a voltaic couple. (See *Couple, Voltaic*.)

Elements, Electrical Classification of — — A classification of the chemical elements into two groups or classes according to whether they appear at the anode or cathode when electrolyzed.

The chemical elements may be arranged into electro-positive and electro-negative according to whether, during electrolysis, they appear at the negative or positive terminal of the source respectively.

The electro-positive elements or radicals are called *kathions*, and appear at the cathode or electro-negative terminal. The electro-negative

elements are called *anions*, and appear at the anode, or the electro-positive terminal. (See *Ions*.)

The metals generally are electro-positive; oxygen, chlorine, iodine, fluorine, etc., are electro-negative.

Elements, Magnetic, of a Place — —

The values of the magnetic intensity, the magnetic declination or variation, and the magnetic inclination or dip at any place.

Elevator Annunciator.—(See *Annunciator, Elevator*.)

Elevator, Electric — — An elevator operated by electric power.

Elongated Ring Core.—(See *Core, Ring, Elongated*.)

Elongation, Magnetic — — An increase in the length of a bar of iron on its magnetization.

This increase in length is thought to greatly strengthen Hughes' theory of magnetism. (See *Magnetism, Hughes' Theory of*.)

Elongation of Needle.—(See *Needle, Elongation of*.)

Embossed, Telegraphic — — An apparatus for recording a telegraphic message in raised or embossed characters.

Emptied.—A term sometimes applied to a completely discharged secondary or storage cell.

It is difficult to determine exactly when a storage cell is completely emptied or "discharged." The cell is generally regarded as discharged when its voltage falls below a certain point.

Endosmose.—The unequal mixing of two liquids or gases through an interposed medium.

The presence of an electric current affects the endosmose. (See *Currents, Diaphragm*.)

Endosmose, Electric.—Differences in the level of liquids capable of mixing through the pores of a diaphragm separating them, produced by the flow of an electric current through the liquid.

Wiedemann, who investigated these phenomena, employed a porous earthenware vessel closed at the bottom and terminated at its upper end by a glass bell provided with a glass tubulure, to

which was attached a horizontal arm for the escape of the liquid raised in the tubulure. The battery terminals were attached to platinum electrodes placed respectively inside the porous cell, and in a vessel of water outside of the porous cell, in which the porous cell was placed; on the passage of the current from the outside of the cell to the inside the liquid rose in the glass tubulure and ran over the horizontal tube into a vessel placed ready to receive it.

Energizing, Electrically — — Causing electricity to produce any effect in an electro-receptive device.

An electro-magnet is energized by the passage of a current through its coils.

Energy.—The power of doing work.

The amount of work done is measured by the product of the *force*, by the *space* through which the force moves. Thus one pound raised vertically through ten feet, ten pounds raised through one foot, or five pounds raised through two feet, all represent the same amount of work; viz., ten *foot-pounds*.

If a weight of ten pounds be raised through a vertical height of one foot, by means of a string passing over a pulley, there will have been expended an amount of energy represented by the work of ten foot-pounds. If the weight be prevented in any way from falling, as by securing the string to a fixed support, the weight will have stored in it an amount of energy equal to ten foot-pounds, and if permitted to fall, will be capable of doing an amount of work which, leaving out air resistance and friction, is exactly equal to that originally expended in raising it to the position from which it fell; viz., ten foot-pounds of work.

Energy, Actual — — Energy actually employed in doing work as distinguished from energy that only possesses the power of doing work, but not actually doing such work.

This term is also used in the sense of kinetic energy or energy due to motion, but kinetic energy is no more actual than potential energy.

Energy, Atomic — — Chemical-potential energy. (See *Energy, Chemical-Potential*.)

Energy, Chemical-Potential — — The potential energy possessed by the elementary chemical atoms. (See *Energy, Potential*.)

If a weight of one pound be raised vertically

against the earth's attraction, through a distance of say ten feet, and placed on a suitable support, an amount of energy, equal to the ten foot-pounds of work done on the weight, becomes potential.

In the same manner if the elementary atoms of carbon and oxygen, when combined so as to form carbonic acid, are raised or separated from one another sufficiently to decompose the carbonic acid and separate the carbon from the oxygen, the amount of potential energy the carbon and oxygen possess, as a result of having been separated, is equal precisely to that originally required to separate them. In this manner each chemical element possesses a store of chemical potential energy peculiar to it, and any element with which it may subsequently enter into combination. When elements combine chemically this potential energy is expended in producing heat.

Energy, Conservation of — —The indestructibility of energy.

The total quantity of energy in the universe is unalterable.

The total energy of the universe is not, however, available for the production of work useful for man.

When energy disappears in one form it reappears in some other form. This is called the *conservation* or *indestructibility* of energy. The commonest form in which energy reappears is as *heat*, and in this case some of the heat is lost to the earth by radiation. This *degradation* or *dissipation of energy* causes some of the energy of the earth to become *non-available* to man.

Energy is therefore *available* and *non-available*. (See *Entropy*.)

Energy, Correlation of — —A term sometimes applied to the different phases under which energy may appear.

Since energy is indestructible, when it disappears in one form or phase, it must reappear in another form or phase. The correlation of the different phases of energy, therefore, necessarily follows from the fact that all energy is indestructible.

Energy, Degradation of — —Such a dissipation of energy as to render it non-available to man. (See *Energy, Conservation of. Entropy*.)

Energy, Dissipation of — —The expenditure or loss of available energy.

Energy, Electric — —The power which electricity possesses of doing work.

In the case of a liquid mass at different levels, the liquid at the higher level possesses a certain amount of *potential energy* measured by the *quantity* of the liquid at the higher level, and the *excess of its height over that of the lower level*; or, by the difference between the two levels. Any difference of level will produce a flow of the liquid *from the higher to the lower level*, and during the flow of this current of liquid, potential energy will be lost, and a certain amount of work will be done.

In the case of electricity, the *difference of electric level*, or *potential*, between any two points of a conductor, causes an electric current to flow between these points toward the lower electric level, during which *electric potential energy* is lost, and *work* is accomplished by the electric current. (See *Potential, Electric*.)

The amount of this electric work is measured by the *quantity of electricity* that flows, multiplied by the *difference of potential* under which it flows. (See *Foule. Volt-Coulomb*.)

Electric energy, however, is generally measured in *electric power*, or *rate of doing electric work*.

Since an *ampère* is one *coulomb-per-second*, if we measure the difference of potential in *volts*, the product of the ampères by the volts will give the electrical power in *volt-ampères*, or *watts*, or *units of electric power*. $C E = \text{Watts}$. (See *Ampère. Volt. Watt*.)

One *horse-power* equals 550 foot-pounds per second. One watt or volt-ampère = $\frac{1}{746}$ of a horse-power, or one *horse-power* equals 746 *volt ampères* or *watts*, therefore:

The current in ampères, multiplied by the difference of potential in volts, divided by 746, equals the rate of doing work in horse-powers.

Thus, if .7 ampère is required to operate a 16 candle, 110 volt, incandescent lamp, it requires 4.8 *watts* per candle.

One Watt = 44.2394 foot-pounds per minute.

One Watt = .737324 foot-pound per second.

The *Heat Activity*, or the heat-per-second produced by an electric current, is also proportional to the product $C E$, or the watts, for the heat is proportional to the *square* of the current in *ampères* multiplied by the *resistance* in ohms, or $C^2 R = \text{the watts}$. (See *Calorimeter, Electric*.)

By *Ohm's Law* (See *Ohm's Law*)

$$C = \frac{E}{R} \quad (1), \text{ or } C R = E \quad (2),$$

But the electric power, or the watts, = $C E$ (3).

If, now, we substitute the value of E , taken from equation (2) in equation (3) we have

$$C E = C \times C R = C^2 R;$$

therefore $C^2 R = \text{Watts}$.

To determine the heating power of a current in *small calories*, calling H , the amount of heat required to raise 1 *gramme* of water through 1° Cent., and C , the current in ampères—

$$H = C^2 R \times .24.$$

Or, for any number of seconds, t ,

$$H = C^2 R t \times .24.$$

(See *Calorie*.)

But from *Ohm's Law*,

$$C = \frac{E}{R} \quad (1),$$

and the formula for electric power or the watts = $C E$. (2) By substituting in equation (2) and the value of C , in equation (1),

$$C E = E \times \frac{E}{R} = \frac{E^2}{R} = \text{Watts}.$$

That is to say, the electric power in any part of a circuit varies directly as the *square* of the *electromotive force*.

We, therefore, have three expressions for the value of the watt, or the *unit of electric power*, viz.:

$$C E = \text{Watts.} \quad (1)$$

$$C^2 R = \text{Watts.} \quad (2)$$

$$\frac{E^2}{R} = \text{Watts.} \quad (3)$$

(1.) $C E = \text{Watts}$; or the electric power is proportional to the product of the *quantity of electricity per-second*, that passes, in *ampères*, and the *difference of electric potential or level*, through which it passes, in volts.

(2.) $C^2 R = \text{Watts}$; or the electric power varies *directly* as the *resistance* R , when the *current is constant*, or as the *square of the current*, if the *resistance is constant*. That is to say, if with a given resistance the power of a given current has a certain value, and the current flowing through this same resistance be *doubled*, the power is *four times as great*, or is as the square of the current.

(3.) $\frac{E^2}{R} = \text{Watts}$, or the electric power is *in-*

versely as the *resistance* R , when the *electromotive force is constant*, and is *directly proportional to the square of the electromotive force if the resistance is constant*.

A circuit of *one ohm* resistance will have a power of *one watt*, when under an electromotive force of *one volt*, since it would then have a current of *one ampère* flowing through it, and $C E = 1$. If, however, the resistance be halved or becomes .5 ohm, then two ampères pass, or the power equals 2 watts.

The power varies as the *square of the electromotive force* in any part of a circuit, when the *resistance is constant* in that part. Thus 2 ampères, and 2 volts, in a circuit of one ohm resistance, give a power, $C E = 2 \times 2 = 4$ watts. If now, R , remaining the same, the electromotive force be raised to 4 volts, then since E , is doubled, C , or the ampères, is doubled, and C

$$\times E = 4 \times 4 = 16 \text{ watts, or } \frac{E^2}{R} = \frac{16}{1} = 16.$$

Energy, Electric, Transmission of —

—The transmission of mechanical energy between two distant points connected by an electric conductor, by converting the mechanical energy into electrical energy at one point, sending the current so produced through the conductor, and reconvertng the electrical into mechanical energy at the other point.

A system for the electric transmission of energy embraces:

(1.) *A conducting circuit* between the two stations.

(2.) *An electric source* or battery of electric sources or machines at one of the stations, generally in the form of a dynamo-electric machine or machines, for converting mechanical energy into electric energy.

(3.) *Electro-receptive devices*, generally *electric motors*, at the other station for reconvertng the electric into mechanical energy. (See *Motor, Electric*.)

Energy, Flow of — —The flow or transmission of energy from the medium or dielectric surrounding a conductor which is directing a current of electricity on to the conductor. (See *Law, Poynting's*.)

Energy, Hysterisial, Dissipation of —

—The dissipation of energy by means of

hysteresis. (See *Energy, Dissipation of Hysteresis*.)

Energy, Kinetic — —Energy which is due to motion as distinguished from potential energy. (See *Energy, Potential*.)

Energy-Meter.—(See *Meter, Energy*.)

Energy of Position.—(See *Position, Energy of*.)

Energy of Stress.—(See *Stress, Energy of*.)

Energy, Potential — —Stored energy. Potency, or capability of doing work.

Energy possessing the power or potency of doing work, but not actually performing such work.

The capacity for doing work possessed by a body at rest, arising from its position as regards the earth, or from the position of its atoms as regards other atoms, with which it is capable of combining.

A pound of coal, if raised vertically one foot, possesses, as a mere weight, an amount of energy capable of doing an amount of work equal to one foot-pound. The atoms of carbon, however, of which it is composed, have been *raised or separated from those of oxygen*, or some other elementary substance, and when the coal is burned, or the carbon atoms fall towards the oxygen atoms (*i. e.*, unite with them), the coal gives up the potential energy of its atoms in the form of heat.

All elementary substances possess in the same way *atomic or chemical-potential energy*, or the energy with which they tend to fall together, or enter into combination. This energy varies in amount in different elements and becomes kinetic, as heat, on combination with other elements. (See *Energy, Chemical-Potential*.)

Energy, Radiant — —Energy transferred to or charged on the universal ether.

Radiant energy is of three forms, *viz.*:

- (1.) Obscure radiation, or heat.
- (2.) Luminous radiation, or light.
- (3.) Electro-magnetic radiation.

Energy, Static — —A term used to express the energy possessed by a body at rest, resulting from its position as regards other bodies, in contradistinction to kinetic energy or the energy possessed by a body whose

atoms, molecules or masses are in actual motion.

Potential energy.

The general term for static energy is *potential energy*. (See *Energy, Potential*.)

Energy, Storage of — —The change from any form of kinetic energy, to any form of potential energy. (See *Energy, Kinetic, Energy, Potential*.)

Engine, Electro-Magnetic — —A motor whose driving power is electricity. (See *Motor, Electric*.)

Engraving, Acoustic — —Engraving by the human voice.

In the *Phonograph, Graphophone and Gramophone*, a diaphragm, set in vibration by the speaker's voice, cuts or engraves a record of its to-and-fro movements on a sheet of tin foil, a cylinder of hardened wax, or a specially coated plate of metal or glass. This record is employed in order to *reproduce the speech*. (See *Phonograph*.)

Engraving, Electric — —A method for electrically etching or engraving a metallic plate by covering it with wax, tracing the design on the wax so as to expose the metal, connecting the metal with the positive terminal of a battery, and placing it in a bath opposite another plate of metal.

By the action of electrolysis the metal is *dissolved* from the exposed portions and *deposited* on the plate connected with the other terminal of the battery. (See *Electrolysis*.)

In this manner the design is obtained in the form of an etching or cutting of the plate.

By connecting the waxed plate to the negative terminal of the electric source, the metal will be *deposited* on the exposed portions of the plate, thus producing the design in relief. Unless great care is taken, this latter method is not, however, apt to produce a sufficiently uniform deposit to enable the plate so formed to be used for printing from.

Electric engraving is sometimes called *electro-etching*.

Entropy.—In thermo-dynamics the non-available energy in any system.—(*Clausius and Mayer*.)

In thermo-dynamics, the available energy in any system.—(*Tait, Thomson and Maxwell*.)

As will be noticed, this term is used in entirely different and opposite senses by different scientific men. The latter sense is, perhaps, the one most generally taken.

Heat energy is available for doing useful external work only when the source of heat utilized is hotter than surrounding bodies, that is, when the heat is transferred from a hotter to a colder body. When all bodies have acquired the same temperature, they can do no more external work. In the various transformations of energy some of the energy is converted into heat, and this heat is gradually diffused through the universe and thus becomes non-available to man. Therefore, the entropy of our earth is decreasing.

"Entropy, in thermo-dynamics," says Maxwell, "is a quantity relating to a body such that its increase or diminution implies that heat has entered or left the body. The amount of heat which enters or leaves the body is measured by the product of the increase or diminution of entropy into the temperature at which it takes place."

Entropy, Electric — —A term proposed by Maxwell for use in thermo-electric phenomena to include the doctrine of entropy in electric science.

"When an electric current," says Maxwell, "passes from one metal to another, heat is emitted or absorbed at the junction of the metals. We should, therefore, suppose that the electric entropy has diminished or increased when the electricity passes from one metal to the other, the electric entropy being different according to the nature of the medium in which the electricity is, and being affected by its temperature, stress, strain, etc."

Equalizer, Feeder — —An adjustable resistance placed in the circuit of a feeder for the purpose of regulating the difference of potential at the junction box.

Equalizer, Magnetic — —A device for equalizing the otherwise unequal force exerted between a magnet pole and its armature at varying distances.

Since the force of magnetic attraction increases rapidly with the decrease of the distance, it follows that any force sufficiently great to cause the motion of an armature towards a pole, against the force of gravity, will result in the movement of the armature to the pole, and that, therefore, no differentiation as to the final result will be produced

by a powerful current, and a current just strong enough to start the action. If, however, the armature move against the action of a spring, the latter can be so arranged that the force with which it opposes the motion of the armature increases, the nearer the armature is to the pole, and in this way the movement of the armature can be made proportional to the strength of the current energizing the electro-magnet.

A similar method consists in mechanical devices that cause the armature to work with lessened mechanical advantage as it approaches the pole.

Or, the polar surfaces may be so shaped by cutting, or by the addition of suitable projections, as to cause the approach of the armature to be attended by a nearly constant force.

Equator, Geographical — —An imaginary great circle passing around the earth midway between its poles.

Equator, Magnetic — —The magnetic parallel or circle on the earth's surface where a magnetic needle, suspended so as to be free to move in a vertical as well as in a horizontal plane, remains horizontal.

An irregular line passing around the earth approximately midway between the earth's magnetic poles. (See *Dip or Inclination, Angle of*.)

Equator of Magnet.—(See *Magnet, Equator of*.)

Equatorial.—Pertaining to the equator.

Equatorially.—In the direction of the equator.

Equipotential Surface of a Conductor through which a Current is Flowing.—(See *Surface, Equipotential, of a Conductor through which a Current is Flowing*.)

Equipotential Surface, or Level Surface of Escaping Fluid.—(See *Surface, Equipotential, or Level Surface of Escaping Fluid*.)

Equipotential Surfaces, Electrostatic — —(See *Surfaces, Equipotential, Electrostatic*.)

Equipotential Surfaces, Magnetic — —(See *Surfaces, Equipotential, Magnetic*.)

Equivalence, Electro-Chemical, Law of — —The amount of chemical action produced by an electric current, passed through various chemical substances, is proportional to the chemical equivalent of each substance,

that is, to its atomic weight, divided by its valency. (See *Valency*.)

Thus, the atomic weight of oxygen is sixteen times greater than the atomic weight of hydrogen. Oxygen is a diad; that is, has twice the combining power of hydrogen. The passage of a given quantity of electricity will liberate eight times, by weight, as much oxygen as hydrogen; or, to put it in another way, the passage of a given quantity of electricity will liberate two atoms of hydrogen for every atom of oxygen.

The atomic weight of chlorine is 35.4. The passage of a given amount of electricity will liberate a weight of chlorine 35.4 greater than the weight of hydrogen; or, for every atom of chlorine it will liberate one atom of hydrogen. Here the passage of a given amount of electricity liberates one atom of the monad element hydrogen for every atom of the monad element chlorine.

The atomic weight of gold is 196.2, and its atomicity or valency is 3. The passage of a given amount of electricity will liberate $\frac{196.2}{3} = 65.4$ in *ic* compounds as great a weight of the triad element gold as of hydrogen; or, will liberate them in the proportion of one atom of gold for every three atoms of hydrogen.

Generalizing, it appears, therefore, that the passage of the same quantity of electricity through an electrolyte liberates the same number of atoms of a monad element, no matter what their nature may be. It liberates one-half as many of the diad atoms as it does of the monads, and one-third as many of the triad atoms as of the monads.

Professor Lodge points out, that assuming the truth of the theory that a current of electricity flows in an electrolyte by means of a true electric convection, each atom carrying an electric charge, then it would seem that every monad atom carries an equal charge of electricity, whether it be an atom of hydrogen, chlorine, potassium, silver, or mercury. That each diad element carries twice as much, and that each triad element carries three times as much.

In general, the number of atoms liberated by a given current of electricity is equal to the number of atoms of hydrogen, divided by the valency of the atom. "The electric charge," says Lodge, "belonging to each atom of matter, is a simple multiple of a definite quantity of electricity, which quantity is an absolute constant, quite independent of the nature of the particular substance to which the atom belongs."

The specific charge thus hypothetically given to each atom of matter is believed never to be lost.

Atoms capable of entering into combination are supposed to be oppositely charged, and chemical affinity is, according to this supposition, believed to be the result of the mutual attractions of opposite electric charges naturally and originally possessed by the atoms of matter.

Lodge points out the following results which naturally flow from the hypothesis that the atoms of matter possess definite positive and negative charges of electricity, viz.:

(1.) That the amount of electricity possessed by each monad atom is exceedingly small, being about the hundred thousand millionth part of the ordinary electrostatic unit, or less than the hundred trillionth of a coulomb.

(2.) The charge being small, the potential is necessarily low.

Probably something between one and three volts is a high difference of potential between two oppositely charged atoms.

(3.) The nearness of the attracting atoms, however, can cause a very strong electrostatic attraction between them.

(4.) That chemical affinity, or atomic attraction, is caused by the presence of these electric charges.

(5.) That the electrical force between two atoms at any distance is ten thousand million billion billion times greater than their gravitation attraction at the same distance, or, the force has an intensity per unit of mass capable of producing an acceleration, nearly one trillion times greater than that of gravity at the earth's surface.

Equivalent, Chemical — — The quotient obtained by dividing the atomic weight of any elementary substance by its atomicity. (See *Weight, Atomic, Atomicity*.)

The ratio between the quantity of an element and the quantity of hydrogen it is capable of replacing.

That quantity of an elementary substance that is capable of combining with or replacing one atom of hydrogen.

The chemical equivalent has a different value from the atomic weight whenever the valency is greater than unity. Thus the atomic weight of gold is 196.2, but since in *ic* compounds one atom of gold is capable of combining with three atoms of hydrogen, the weight of the gold equivalent to that of one atom of hydrogen is one-third of 196.2, or 65.4.

Equivalent Conductivity.—(See *Conductivity, Equivalent*.)

Equivalent, Electro-Chemical — —A number representing the weight in grammes of an elementary substance liberated during electrolysis by the passage of one coulomb of electricity. (See *Electrolysis, Coulomb*.)

The chemical equivalent of a substance multiplied by the electro-chemical equivalent of hydrogen.

The electro-chemical equivalent is, therefore, found by multiplying the electro-chemical equivalent of hydrogen by the chemical equivalent of the element.

It may be determined experimentally that one coulomb of electricity, expended electrolytically, will liberate .0000105 gramme of hydrogen. Therefore a current of one *ampère*, or one *coulomb-per-second*, will liberate .0000105 gramme of hydrogen per second. The number .0000105 is the electro-chemical equivalent of hydrogen.

In the same manner the electro-chemical equivalents of the other elements are obtained by multiplying the electro-chemical equivalent of hydrogen by the chemical equivalent of the substance.

Thus, the chemical equivalent of potassium is 39.1, therefore its electro-chemical equivalent is $39.1 \times .0000105 = .00041055$. By multiplying the strength of the current that passes by the electro-chemical equivalent of any substance we obtain the weight of that substance liberated by electrolysis. (See *Equivalence, Electro-Chemical, Law of*.)

To determine the electro-chemical equivalent of the other elements see table of chemical equivalents on page 212.

Equivalent, Joule's — —The mechanical equivalent of heat. (See *Heat, Mechanical Equivalent of*.)

Equivalent of Heat, Mechanical — — (See *Heat, Mechanical Equivalent of*.)

Equivalent Resistance.—(See *Resistance, Equivalent*.)

Equivolt.—A term proposed by J. T. Sprague for the unit of electrical energy, applied especially to chemical decomposition.

Sprague defines an equivolt as follows: "The mechanical energy of one volt electromotive force exerted under unit conditions through one equivalent of chemical action in grains."

This term has not been generally accepted. (See *Volt-Coulomb, Joule*.)

Erb's Standard Size of Electrodes.—(See *Electrodes, Erb's Standard Size of*.)

Erg.—The unit of work, or the work done when unit force is overcome through unit distance.

The work accomplished when a body is moved through a distance of one centimetre with the force of one dyne. (See *Dyne*.)

A dyne centimetre.

The work done when a weight of one gramme is raised against gravity through a vertical height of one centimetre is equal to 981 ergs, because the weight of one gramme is 1×981 dynes, or 981 ergs.

The following values for the erg, the unit of work, and the dyne, the unit of force, are taken from Hering:

1 erg = 1 dyne centimetre.

1 erg = 0.000001 joule.

981 ergs = 1 gramme centimetre.

1,937.5 ergs = 1 foot grain.

13,562,600 ergs = 1 foot-pound.

1 dyne = 1.0194 milligrammes.

1 dyne = 0.015731 grain.

1 dyne = 0.0010194 grammes.

1 dyne = 0.0003596 ounce avoirdupois.

63,568 dynes = 1 grain.

981 dynes = 1 gramme.

Ergmeter.—An apparatus for measuring the work of an electric current in ergs.

Erg-ten.—A term proposed for ten million ergs or $1 \times 10^{10} = 10,000,000,000$.

In representing large numbers containing many ciphers the following plan is generally adopted for representing the number of ciphers that are to be added to a given number. Thus, suppose it is desired to represent the number 3,800,000,000. When written 38×10^8 it indicates that 38 is to be multiplied by 10^8 or 100,000,000, or, in other words, that 38 is to be followed by 8 ciphers, thus 3,800,000,000.

A negative exponent, as 3×10^{-8} represents the corresponding decimal thus, .00000003.

1 erg $\times 10^{10}$, or 10,000,000,000 is called an *erg-ten*. $1 \times 10^6 =$ an *erg-six*. These terms are not in general use. Ten meg-ergs is a preferable phrase to an erg-ten. (See *Meg-erg*.)

Escape, Electric — —A term some-

times employed to indicate the loss of charge on an insulated conductor. (See *Leakage, Electric.*)

Escaping Fluid, Flow-Lines of — —
(See *Flow-Lines of Escaping Fluid.*)

Escaping Fluid, Stream-Lines of — —
(See *Stream-Lines of Escaping Fluid.*)

Essential Resistance.—(See *Resistance, Essential.*)

Etching, Electro — — — A term sometimes employed instead of electro-engraving. (See *Engraving, Electric.*)

Etching, Galvanic — — — Electro-Engraving. (See *Engraving, Electric.*)

Ether.—The tenuous, highly elastic fluid that is assumed to fill all space, and by vibrations or waves in which light and heat are transmitted.

Although the existence of the ether is assumed in order to explain certain phenomena, its actual existence is very generally credited by scientific men, and, in reality, proofs are not wanting to fairly establish such existence.

Light and heat are believed to be due to transverse vibrations in the ether. Magnetism appears to be due to whirls or whirlpools, and an electric current is believed by some to be due to pulses of waves of ether set in motion by differences in the ether pressures.

It is not correct to regard the luminiferous ether as possessing no weight, or as being imponderable. Maxwell estimates its density as

$\frac{936}{1,000,000,000,000,000,000,000,000}$ that of water. It

is very readily moved or set into vibration, its rigidity being estimated at about $\frac{1}{1,000,000,000}$ that of steel.

According to the speculations of some physicists the ether is not discontinuous or granular, but it is similar to what might be regarded as an almost impalpable jelly.

Ethereal.—Pertaining to the universal ether.

Eudiometer.—A voltameter in which separate graduated vessels are provided for the reception and measurement of the gaseous products evolved during electrolysis. (See *Voltameter.*)

In all cases electrodes for eudiometers must be used which do not enter into combination with the evolved gaseous products. In the case of oxygen and hydrogen, platinum is generally used.

A form of eudiometer is shown in Fig. 241.

Two separate glass vessels, provided at the top with stop cocks, and open at their lower ends, rest in a vessel of water A, over platinum electrodes, connected electrically with binding posts K, K. Both vessels are filled with water slightly acidulated with sulphuric acid, and, when connected with a battery of sufficient electromotive force (not less than 1.45 volts), electrolysis takes place,

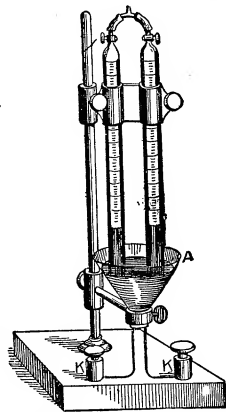

Fig. 241. Eudiometer.

and hydrogen gas collects in the vessel over the platinum electrode connected with the negative battery terminal, and oxygen in the vessel over the electrode connected with the positive battery terminal. The volume of the hydrogen is approximately twice as great as that of the oxygen. (See *Water, Electrolysis of.*)

The proportion is not exactly 2 to 1, because,

(1.) Some of the hydrogen is occluded or absorbed by the platinum electrode.

(2.) Some of the oxygen is given off as triatomic oxygen, or ozone, which is denser and occupies less space than free atomic oxygen.

Eudiometric.—Pertaining to the eudiometer. (See *Eudiometer.*)

Eudiometrically.—By means of the eudiometer.

Evaporation.—The change from the liquid to the vaporous state.

Wet clothes exposed to the air are dried by the evaporation of the water.

Evaporation is greater:

- (1.) The more extended the surfaces exposed.
- (2.) The higher the temperature of the air.
- (3.) The dryer the air, or the smaller the quantity of vapor it contains already.
- (4.) The stronger the wind.
- (5.) The smaller the barometric pressure.

Evaporation, Electric — — — The forma-

tion of vapors at the surfaces of substances by the influence of negative electrification.

The term electric evaporation was proposed by Crookes for the formation of metallic vapors of such substances as metallic platinum, exposed in high vacua to the effects of negative electrification. He shows that under these circumstances the surface molecules of the platinum lose their power of cohering and fly off into the space around them, *i. e.*, suffer true evaporation. This action takes place under atmospheric pressures, but, like ordinary evaporation, is greatly facilitated by the presence of a high vacuum.

True electric evaporation takes place with liquids as well as with solids. In an experiment with water, the influence of the kind of the electrification was clearly shown. A vessel of water

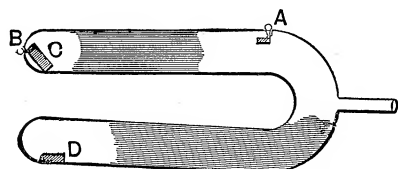

Fig. 242. Electrical Evaporation.

exposed to the air was first positively electrified, but after an exposure of $1\frac{3}{4}$ hours only a trifling evaporation was noticeable. The water was then negatively electrified, and at the end of $1\frac{1}{2}$ hours had lost $\frac{1}{1000}$ part of its weight more than did the positively charged water.

Professor Crookes experimented with cadmium, and, in order to show that electric evaporation is different from evaporation produced by the agency of heat, tried the following, *viz.*: A high vacuum U-tube, shaped as shown in Fig. 242, was pro-

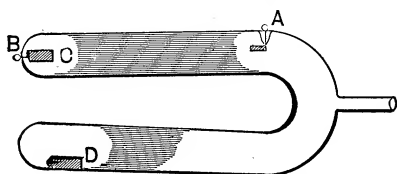

Fig. 243. Electrical Evaporation.

vided with platinum poles sealed in the glass at A and B. Two pieces of cadmium, C and D, were placed in the tube in the position shown, and the tube uniformly heated by means of a gas-burner and air bath, and maintained at a constant temperature. The current was then passed for about an hour, B, being made the negative pole.

No metal was deposited in the neighborhood of the positive pole, the portions of the tube surrounding the positive pole being quite clean, while the corresponding portions of the other limb of the tube were thickly coated, as shown by the shading in the drawing.

In another experiment, in which the temperature was kept lower than in the preceding, *viz.*, just below the melting point of the cadmium, after the current had passed for an hour, the limb of the tube through which the current had passed had received a thick coating, while the other was nearly free from coating, as shown in Fig. 243. Here the increase in the amplitude of the molecular oscillation under the influence of the electricity is manifest.

Evaporation, Electrification by — —

An increase in the difference of potential existing in a mass of vapor attending its sudden condensation.

The free electricity of the atmosphere is believed by some to be due to the condensation of the vapor of the air that results in rain, hail, clouds, etc. It is probable, however, that the true effect of condensation is mainly limited to the increase of a feeble electrification already possessed by the air or its contained vapor. The small difference of potential of the exceedingly small drops of water in clouds is enormously increased by the union or coalescing of many thousands of such drops into a single rain drop. (See *Electricity, Atmospheric.*)

Exchange, Telephonic, System of — —

—A combination of circuits, switches and other devices, by means of which any one of a number of subscribers connected with a telephonic circuit, or a neighboring telephonic circuit or circuits, may be placed in electrical communication with any other subscriber connected with such circuit or circuits.

A telephone exchange consists essentially of a multiple switchboard, or a number of multiple switchboards, furnished with *spring-jacks*, *annunciator drops*, and suitable *connecting cords*. A *call bell*, or bells, is also provided. The annunciator drops are often omitted. (See *Board, Multiple Switch.*)

Excitability, Electric, of Nerve or Muscular Fibre — — The effect produced by an electric current in stimulating the nerve of a

living animal, or in producing an involuntary contraction of a muscle.

Du Bois-Reymond has shown that these effects depend :

(1.) On the strength of the current employed. The excitability occurs only when the current begins to flow, and when it ceases flowing; or, when the electrodes first touch the nerves, and when they are separated from it. Subsequent investigations have shown that this is true only for the frog's nerves, and is true for the human nerves only in the case of moderate currents, strong currents producing tetanus.

(2.) On the rapidity with which the current used reaches its maximum value, that is, on the rapidity of change of *current density*. (See *Current Density*.)

Excitability, Electro-Nervous — — In electro-therapeutics the electric excitation of a nerve.

Excitability, Electrotonic — — The actual excitability of a nerve when in the electrotonic condition. (See *Electrotonus*, *Anelectrotonus*, *Kathelectrotonus*.)

Excitability, Faradic — — Muscular or nervous excitability following the employment of the rapidly intermittent currents produced by induction coils. (See *Coil, Induction*.)

Faradic excitability is different from *galvanic excitability*, or that produced by means of a continuous voltaic current. (See *Excitability, Galvanic*.)

Excitability, Galvanic — — A term sometimes employed for electric excitability of nerve or muscular fibre. (See *Excitability, Electric, of Nerve or Muscular Fibre*.)

Excitation, Compensated, of Alternator. — (See *Alternator, Compensated Excitation of*.)

Excitation, Direct — — The excitement of a muscle by placing an electrode on the muscle itself.

Excitation, Electro-Muscular — — In electro-therapeutics the galvanic or faradic excitation of the muscle, or its excitation by the continuous currents of a voltaic battery, or the alternating currents of an induction coil.

Excitation, Faradic — — Excitation of muscle or nerve fibre by means of rapidly

alternating currents of electricity. (See *Excitability, Faradic*.)

Excitation, Indirect — — The excitement of a muscle from its nerve.

Exciter of Field.—(See *Field, Exciter of*.)

Exciting Liquid of Voltaic Cell.—(See *Cell, Voltaic, Primary, Exciting Liquid of*.)

Execution, Electric — — Causing the death of a criminal, in cases of capital punishment, by means of the electric current.

Electric execution has been adopted by the State of New York, in accordance with the following law :

“The Court shall sentence the prisoner to death within a certain week, naming no day or hour, and not more than eight nor less than five weeks from the day of sentence. The execution must take place in the State prison to which convicted felons are sent by the Court, and the executioner must be the agent and warden of the prison.

“No newspaper may print any details of the execution, which is to be inflicted by electricity. A current of electricity is to be caused to pass through the body of the condemned of sufficient intensity to kill him, and the application is to be continued until he is dead.”

Exhaustion, Electric — — Physiological effects resembling those produced by sun-stroke, resulting from prolonged exposure to the radiation of unusually large voltaic arcs. (See *Sun-Stroke, Electric*.)

Exhaustion of Primary Voltaic Cell.—(See *Cell, Voltaic, Primary, Exhaustion of*.)

Exhaustion of Secondary Voltaic Cell.—(See *Cell, Voltaic, Secondary, Exhaustion of*.)

Exhaustion of Voltaic Cell.—(See *Cell, Voltaic, Exhaustion of*.)

Exhaustion, Reaction of — — A condition of nervous and muscular irritability to electric excitation when a certain reaction, produced by a given current strength, cannot be reproduced without an increase of current strength.

The reaction of exhaustion may be regarded as a special variety of the reaction of degeneration. (See *Degeneration, Reaction of*.)

The reaction of degeneration embraces the following modifications of irritability, viz.:

(1.) Disappearance or diminution of nervous irritability to both galvanic and faradic currents.

(2.) Disappearance of faradic and increase of galvanic irritability of muscles, generally associated with an increase of mechanical irritability.

(3.) Disappearance of faradic and increase of galvanic muscular irritability associated generally with increased mechanical irritability.

(4.) Tardy, delayed contraction of muscles instead of quick reaction of normal muscle.

(5.) Marked modifications of normal sequence of contraction.—*Liebig & Rohé.*

Expanding Magnetic Whirl.—(See *Whirl, Expanding Magnetic.*)

Expansion, Co-efficient of — —The fractional increase in the dimensions of a bar or rod when heated from 32 degrees to 33 degrees F. or from 0 degree to 1 degree C.

The fractional increase in the length of the bar is called the *Co-efficient of Linear Expansion.*

The fractional increase in the surface is called the *Co-efficient of Surface Expansion.*

The fractional increase in the volume is called the *Co-efficient of Cubic Expansion.*

Expansion, Electric — —The increase in volume produced in a body on giving such body an electric charge.

A Leyden jar increases in volume when a charge is imparted to it. This result is due to an expansion of the glass due to the electric charge. According to Quincke, some substances, such as resinous or oily bodies, manifest a *contraction of volume* on the reception of an electric charge.

Expansion Joint.—(See *Joint, Expansion.*)

Expansion, Linear, Co-efficient of — —

A number expressing the fractional increase in length of a bar for a given increment of heat.

The co-efficients of expansion of a few substances are given in the following table:

	Temp.	
Aluminium.....	16 to 100 degrees C.	0.0000235
Brass	0 " 100 " "	0.0000188
Copper	0 " 100 " "	0.0000167
German silver..	0 " 100 " "	0.0000184
Glass	0 " 100 " "	0.0000071
Iron	13 " 100 " "	0.0000123
Lead	0 " 100 " "	0.0000280
Platinum	0 " 100 " "	0.0000089
Silver	0 " 100 " "	0.0000194
Zinc	0 " 100 " "	0.0000230

—(*Anthony & Brackett.*)

Exploder, Electric Mine — —A small magneto-electric machine used to produce the currents of high electromotive force employed in the direct firing of blasts.

Exploder, Electro-Magnetic — —A small magneto-electric machine used to produce the currents of high electromotive force employed in the direct firing of blasts.

Explorer, Electric — —An apparatus operated by means of induced currents, and employed for the purpose of locating bullets or other foreign metallic substances in the human body. (See *Balance, Induction, Hughes.*)

Explorer, Magnetic — —A small, flat coil of insulated wire, used, in connection with the circuit of a telephone, to determine the position and extent of the magnetic leakage of a dynamo-electric machine or other similar apparatus. (See *Magnetophone.*)

Explosive Distance.—(See *Distance, Explosive.*)

Extension Call-Bell.—(See *Bell, Extension Call.*)

External Circuit.—(See *Circuit, External.*)

External Secondary Resistance. — (See *Resistance, External Secondary.*)

Extra Currents.—(See *Currents, Extra.*)

Extraordinary Resistance.—(See *Resistance, Extraordinary.*)

Extra-Polar Region.—(See *Region, Extra-Polar.*)

Eye, Electro-Magnetic—A term proposed for a certain form of spark-micrometer employed by Hertz in his experiment on electro-magnetic radiation.

This apparatus has received the above name because it enables the observer to see or localize an electromagnetic disturbance.

The particular spark-micrometer that has received the name of the electro-magnetic eye had the form of a circle 35 centimetres in radius, and was formed of a copper wire 2 millimetres in diameter. Like all spark-micrometer circuits, it had its terminals separated by a small air-space.

Eye, Selenium — —An artificial eye in

which a selenium resistance takes the place of the retina and two slides the place of the eyelids.

The selenium resistance is placed in the circuit of a battery and a galvanometer. When the slides L, L, Fig. 244, are shut, the galvanometer deflection is less than when they are open.

The opening of the aperture between the slides L, L, may be automatically accomplished by the action of the light itself, by moving them by an electro-magnet placed in the circuit of a local battery, and a selenium resistance may be so arranged that when light falls on it the slides L, L, are moved together, and when the amount of such light is small they are moved apart, by the action

of a spring. In this way there is obtained a device roughly resembling the dilatation or contraction of the pupil of the eye from the action of light on the iris. (See *Photometer, Selenium.*)

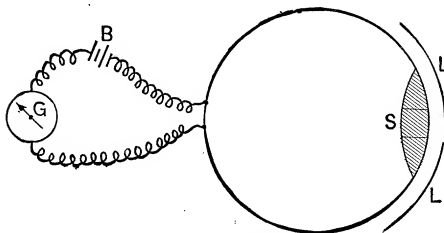

Fig. 244. Selenium Eye.

traction of the pupil of the eye from the action of light on the iris. (See *Photometer, Selenium.*)

F

Fac-Simile Telegraphy, or Pantelegraphy.—(See *Telegraphy, Fac-Simile.*)

Fahrenheit's Thermometer Scale.—(See *Scale, Thermometer, Fahrenheit's.*)

Fall of Potential.—(See *Potential, Fall of.*)

False Magnetic Pole — —(See *Pole, Magnetic, False.*)

False Resistance.—(See *Resistance, False.*)

False Zero.—(See *Zero, False.*)

Fan Guard.—(See *Guard, Fan.*)

Farad.—The practical unit of electric capacity.

Such a capacity of a conductor or condenser that one coulomb of electricity is required to produce in the conductor or condenser a difference of potential of one volt.

As in gases, a quart vessel will hold a quart of gas under unit pressure of one atmosphere, so, in electricity, a conductor or *condenser*, whose capacity is one farad, will hold a quantity of electricity equal to one *coulomb* when under an electromotive force of one volt.

It may cause some perplexity to the student to understand why there should be in electricity one *unit of capacity* to represent the *size* of the vessel or conductor, and another to represent the *amount* or quantity of electricity required to fill

such vessel. But, like a gas, electricity acts, in effect, as if it were very compressible, so that the quantity required to fill any condenser will de-

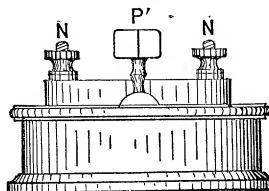

Fig. 245. Elevation of Standardized Condenser.

pend on the electromotive force under which it is put into the conductor or condenser.

For purposes of measurement, capacities of conductors are compared with those of condensers

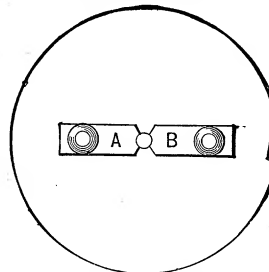

Fig. 246. Plan of Standardized Condenser.

whose capacities are known in microfarads, or fractions thereof. The microfarad, or the $\frac{1}{1,000,000}$ of a farad, is used because of the very great size of a farad.

Fig. 245 shows an elevation, and Fig. 246 a plan of the form often given to a standardized condenser or microfarad. The condenser is charged by connecting the terminals of the electric source to the binding posts N and N'. It is discharged by means of the plug key P', that connects the brass pieces A and B, when pushed firmly into the conical space between them.

The condenser is made by placing sheets of tin foil between sheets of oiled silk or mica in the box and connecting the alternate sheets to one of the brass pieces B, and the other set to the brass piece A, as will be better understood from an inspection of Fig. 247.

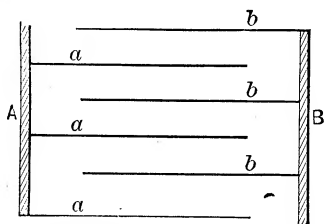

Fig. 247. Method of Construction of a Condenser.

Condensers are generally made of the capacity of the $\frac{1}{3}$ of a *microfarad*. Sometimes, however, they are made so that either all or part of the condenser may be employed, by the insertion of the different plug keys.

The form of condenser shown in Fig. 248 is

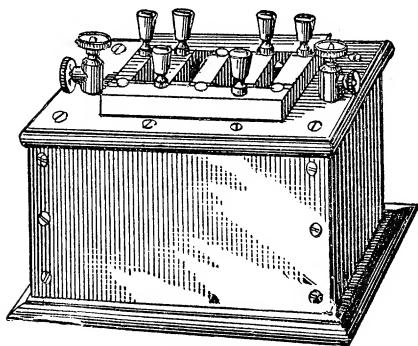

Fig. 248. Standard Condenser.

capable of ready division into five separate values, viz.: .05, .05, .2, .2 and .5 microfarad.

Farad, Micro — —The millionth part of a farad. (See *Farad*.)

Faraday Effect.—(See *Effect, Faraday*.)

Faraday's Cube.—(See *Cube, Faraday's*.)

Faraday's Dark Space.—(See *Space, Dark, Faraday's*.)

Faraday's Net.—(See *Net, Faraday's*.)

Faradic Apparatus, Magneto-Electric — —(See *Apparatus, Faradic, Magneto-Electric*.)

Faradic Brush.—(See *Brush, Faradic*.)

Faradic Current.—(See *Current Faradic*.)

Faradic Excitation.—(See *Excitation, Faradic*.)

Faradic Induction Apparatus.—(See *Apparatus, Faradic Induction*.)

Faradic Irritability.—(See *Irritability, Faradic*.)

Faradic Machine.—(See *Machine, Faradic*.)

Faradization.—In electro-therapeutics, the effects produced on the nerves or muscles by the use of a faradic current, in order to distinguish such effects from galvanization or those produced by a voltaic current. (See *Galvanization*.)

Faradization, General — —A method of applying the faradic current similar to that employed in general galvanization. (See *Galvanization, General*.)

Faradization, Local — —A method of applying the faradic current in general similar to that employed in local galvanization. (See *Galvanization, Local*.)

Fault.—Any failure in the proper working of a circuit due to ground contacts, cross-contacts or disconnections. (See *Contacts, Cross*.)

Faults are of three kinds, viz.:

- (1.) Disconnections. (See *Disconnection*.)
- (2.) Earths. (See *Earth*.)
- (3.) Contacts. (See *Contacts*.)

Various methods are employed for *detecting* and *localizing* faults, for the explanation of which reference should be had to standard electrical works on testing or measurements.

Fault, Ironwork, of Dynamo — —A ground or connection between the current of a dynamo and any part of its ironwork.

If the dynamo is in good connection with the ground, as is frequently the case in marine plants, this fault is the same as a ground.

•**Faults, Localization of** — —Determining the position of a fault on a telegraph line or cable by calculations based on the fall in the potential of the line measured at different points, or by loss of charge, etc.

For details, see standard works on electrical measurements.

Feed, Clockwork, for Arc Lamps — — An arrangement of clockwork for obtaining a uniform feed motion of one or both electrodes of an arc lamp.

The clockwork is automatically thrown into or out of action by an electro-magnet, usually placed in a shunt circuit around the carbons.

Feed, To — —To supply with an electric current, as by a dynamo or other source.

Feeder.—One of the conducting wires or channels through which the current is distributed to the main conductors.

Feeder, Standard or Main — —The main feeder to which the standard pressure indicator is connected, and whose pressure controls the pressure at the ends of all the other feeders.

The term pressure in the above definition is used in the sense of electromotive force or difference of potential.

Feeder-Wires.—(See *Wires, Feeder.*)

Feeders.—In a system of distribution by constant potential, as in incandescent electric lighting, the conducting wires extending between the bus-wires or bars, and the junction boxes.

A feeder differs from a main in that a main consists of a conductor that may be tapped at any point to supply a customer, while a feeder leads direct from the dynamo or other source to a main and is not tapped at any point.

Feeders, Negative — —The feeders that are connected with the negative terminal of the dynamo. (See *Feeders.*)

Feeders, Positive — —The feeders that are connected with the positive terminal of the dynamo. (See *Feeders.*)

Feeding Device of Electric Arc Lamp.— (See *Device, Feeding, of an Arc Lamp. Feed, Clockwork, for Arc-Lamps.*)

Feeding-Wire.—(See *Wire, Feeding.*)

Feet, Ampère — —The product of the current in ampères by the distance in feet through which that current passes.

It has been suggested that the term ampère-feet should be employed in expressing the strength of electro-magnetism in the field magnets of dynamo-electro machines or other similar apparatus.

Ferranti Effect.—(See *Effect, Ferranti.*)

Ferro-Magnetic Substance.—(See *Substance, Ferro-Magnetic.*)

Fibre, Quartz — —A fibre suitable for suspending galvanometer needles, etc., made of quartz.

The quartz fibre is obtained by fusing quartz and drawing out the fused material as a fine thread, in a manner similar to the production of glass fibres. Quartz fibres possess marked advantage over silk fibres, in that they are 5.4 times stronger for equal diameters, and especially, in that they return to the zero point, after very considerable deflections.

Quartz fibres are readily obtained by fusing quartz pebbles together in the voltaic arc, and drawing them apart with a rapid, but steady, uniform motion.

Fibre Suspension.—(See *Suspension, Fibre.*)

Fibre, Vulcanized — —A variety of insulating material suitable for purposes not requiring the highest insulation.

Vulcanized fibre is, however, seriously affected by long exposure to moisture.

Fibron.—An insulating substance.

Field, Air — —That portion of a magnetic field in which the lines of force pass through air only.

Field, Alternating — —An electrostatic or magnetic field the positive direction of the lines of force in which is alternately reversed or changed in direction.

Field, Alternating Electrostatic — — An electrostatic field, the potential of which is rapidly alternating.

An alternating electrostatic field is, according to Tesla's experiments, produced in the neighborhood of the terminals of the secondary of an induction coil, through whose primary, alternations of high frequency are passing.

Field, Alternating Magnetic.—A magnetic field the direction of whose lines of force is alternately reversed.

Field, Density of — —The number of lines of force that pass through any field, per unit of area of cross-section.

Field, Electric — —A term sometimes used in place of an electrostatic field. (See *Field, Electrostatic.*)

Field, Electro-Magnetic — —The space traversed by the lines of magnetic force produced by an electro-magnet. (See *Field, Magnetic.*)

Field, Electrostatic — —The region of electrostatic influence surrounding a charged body.

Electrostatic attractions or repulsions take place along certain lines called lines of electrostatic force. These lines of force produce a field called an *electrostatic field*. *Electric level* or *potential* is measured along these lines, just as gravitation levels are measured with a plumb line along the lines of gravitation force. (See *Potential, Electric.*)

Work is done when a body is moved along the lines of electrostatic force in a direction *from* an oppositely charged body, or *towards* a similarly charged body, just as work is done against gravity when a body is moved along the lines of gravitation force, away from the earth's centre, or vertically upwards.

Field, Exciter of — —In a separately excited dynamo-electric machine, the dynamo-electric machine, voltaic battery, or other electric source employed to produce the field of the field magnets. (See *Machine, Dynamo-Electric.*)

Field, Intensity of — —The strength of a field as measured by the number of lines of force that pass through it per unit of area of cross-section. (See *Field, Electrostatic. Field, Magnetic.*)

Field, Magnetic — —The region of

magnetic influence surrounding the poles of a magnet.

A space or region traversed by lines of magnetic force.

A place where a magnetic needle, if free to move, will take up a definite position, under the influence of the lines of magnetic force.

Unit strength of magnetic field is the field which would be produced by a magnetic pole of unit strength at unit distance.

Magnetic attractions and repulsions are assumed to take place along certain lines called *lines of magnetic force*. The directions of these lines in any plane of a magnetic field may be shown by sprinkling iron filings over a sheet of paper held in a horizontal position to a magnet pole inclined

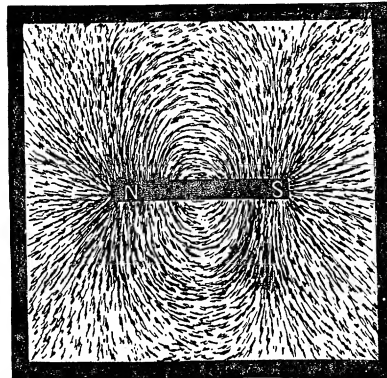

Fig. 249. Magnetic Field.

to the paper in the desired plane and then gently tapping the paper.

The groupings of iron filings so obtained are sometimes called *magnetic figures*.

The directions of the lines of force thus shown will appear from an inspection of Fig. 249, taken in a plane joining the two poles of a straight bar magnet, and Fig. 250, taken in a plane at right angles to the north pole of a straight bar magnet.

In Fig. 249, the repulsion of the lines of force at either pole is shown by the radiation of the chains of magnetized iron particles. The mutual attraction of unlike polarities is shown by the curved lines.

In Fig. 250, the repulsion of the similarly magnetized chains is clearly shown.

Lines of magnetic force are assumed to pass out from the *north pole* and back again into the magnet at its south pole. This assumed direction

is called the *direction of the lines of magnetic force*.

Faraday expressed his conception of lines of magnetic force as follows:

“Every line of force must therefore be considered as a closed circuit, passing, in some part of its course, through a magnet and having an equal amount of force in every part of its course. There

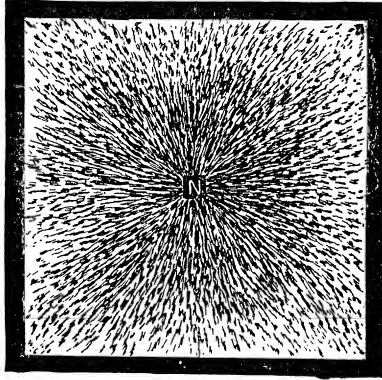

Fig. 250. Magnetic Field.

exist lines of force within the magnet of the same nature as those without. What is more, they are exactly equal in *amount* to those without. They have a relation in direction to those without and are, in fact, continuations of them.”

When a conductor, such as a wire through which a powerful current of electricity is flowing, is dipped in a mass of iron filings, a chain of iron filings is formed, the north end of which is urged around the conductor in one direction and the south end in the opposite direction, so that the movable chain of filings surrounds or grips the conductor in concentric rings or circles.

The *density of a magnetic field* is directly proportional to the number of lines of force per unit of area of cross-section.

A *single line of force*, or a *unit line of force*, is such an intensity of field as exists in each square centimetre of cross-section of a unit magnetic field.

A magnetic field is *uniform*, or possesses *uniform intensity*, when it possesses the same number of lines of force per square centimetre of area of cross-section.

Field, Magnetic, Alternating — — The magnetic field produced by means of an alternating current.

Field, Magnetic, Dissymmetrical — — A field whose lines of force are not symmetrically distributed in adjacent halves.

Field, Magnetic, Expanding of — — An increase in the length of the lines of magnetic force in any field, or an increase in the length of their magnetic circuit.

Field, Magnetic, of an Electric Current — — The magnetic field surrounding a cir-

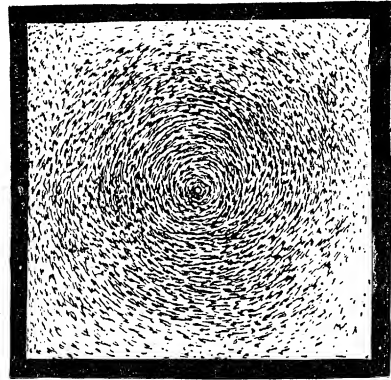
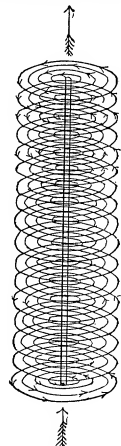

Fig. 251. Field of Current.

cuit through which an electric current is flowing.

An electric current produces a magnetic field. This was discovered by Oersted in 1819, and may be shown by sprinkling iron filings on a sheet of paper, placed on the wire conductor conveying the current, at right angles to the direction in which the current is passing. Here the lines of force appear as concentric circles, extending around the conductor, as shown in Fig. 251. Their direction, as regards the length of the conductor, is shown in Fig. 252. The electric current sets up these *magnetic whirls* around the conductor on its passage through it.



The *direction of the lines of magnetic force* produced by an electric current, and hence its *magnetic polarity*, depends on the direction in which the electric current flows. This direction

may be remembered as follows: If the current flows towards the observer, the directions of the lines of magnetic force is opposite to that of the hands of a watch, as shown in Fig. 253.

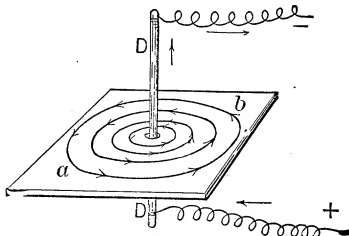

Fig 253. Direction of Lines of Force.

It is from the direction of the lines of magnetic force that the polarity of a helix carrying a current is deduced. (See *Solenoid, Magnetic. Magnet, Electro.*)

A magnetic field possesses the following properties, viz.:

(1.) All magnetizable bodies are magnetized when brought into a magnetic field. (See *Induction, Magnetic.*)

(2.) Conductors moved through a magnetic field so as to cut its lines of force have differences of potential generated in them at different points, and if these points be connected by a conductor, an electric current is produced. (See *Induction, Electro-Magnetic.*)

Field, Magnetic, Pulsatory — —A field, the strength of which pulsates in such manner as to produce oscillatory currents by induction.

Field, Magnetic, Reversing — —That portion of the field of a dynamo-electric machine, produced by the field-magnet coils, in which the currents flowing in the armature coils are stopped or reversed after the coil has passed its theoretical position of neutrality.

Sparkless commutation is obtained by placing the brushes on the commutator so as to correspond with the reversing field.

Field, Magnetic, Shifting — —A term proposed by Professor Elihu Thomson to express a field of magnetic lines of changing position with respect to the axis of the pole from which they emanate.

A shifting magnetic field is especially a phenomenon of a rapidly alternating magnetic field

occurring in a substance like hardened steel in which the coercive force is fairly high. It, for example, a single magnet pole of an electro-magnet, whose coils are traversed by a rapidly alternating current of electricity, is placed near one end of a steel file, the changing polarity developed thereby moves or shifts from the point directly over the pole towards the distant end. The presence of this shifting field can be shown by the rotation of discs of copper suitably inclined to the end of the file. In a similar manner a prismatic mass of steel, placed with one of its flat sides on the pole of a rapidly alternating magnetic field, will have a magnetic field developed in it, which will move or shift from the flat base towards the upper edge. Movable masses of good conducting metal, such as copper, will be set in rotation in a direction such as would be caused by an escape of gas therefrom.

The shifting magnetic field travels from the upper portions of the prism just as a stream of escaping gaseous substance would.

Field, Magnetic, Spreading-Out — —A term sometimes used to represent an expanding magnetic field. (See *Field, Magnetic, Expanding of.*)

Field, Magnetic, Stray — —That portion of the field of a dynamo-electric machine which is not utilized for the development of differences of potential in the armature, because its lines of force do not pass through the armature.

Field, Magnetic, Strength of — —The dynamic force acting on a free magnetic pole, placed in a magnetic field.

If a free magnetic pole could be placed in a magnetic field, it would begin to move towards the opposite pole of the field, under its magnetic attraction, just as an unsupported body, free to move, would begin to fall towards the earth. The strength of a magnetic field corresponds to the acceleration of the force of gravity in the case of a falling body. The strength of the magnetic pole corresponds to the mass of the falling body. The force impressed in the case of the magnetic field is equal to the strength of the pole multiplied by the strength of the field.

Field, Magnetic, Symmetrical — —A field whose lines of force are symmetrically distributed in adjacent halves.

Field, Magnetic, Uniform — —A field traversed by the same number of lines of magnetic force in all unit portions of area of cross-section. (See *Field, Magnetic.*)

Field, Magnetic, Waste — —A term sometimes employed for stray field. (See *Field, Magnetic, Stray.*)

Field, Rotating-Current — —A magnetic field produced by means of a rotating current. (See *Current, Rotating.*)

Field, Uniform Density of — —A uniform density in all equal areas of cross-section of field.

Field, Vortex-Ring — —The field of influence possessed by a vortex-ring.

Professor Dolbear points out the fact that the direction of the rotation of a fluid constituting a vortex-ring resembles the magnet flux in a magnetic field, and shows, from the action of such rings on one another, that they possess a true field, or atmosphere of influence outside their actual bodies. He infers that such rings possess true polarity, since the motions producing them have different directions on opposite sides or ends.

Figure of Merit of Galvanometer.—(See *Galvanometer, Figure of Merit of.*)

Figures, Breath — —Faint figures of condensed vapor produced by electrifying a coin, placing it momentarily on the surface of a sheet of clean, dry glass, and then breathing gently on the spot where the coin was placed.

The moisture collects on the electrified portions of the plate and forms a fairly distinct image of the coin.

Figures, Electric — —Figures of various shapes produced on electrified surfaces by the arrangement of dust particles or vapor vesicles under the influence of electric charges.

Electric figures are of two varieties, viz.:

- (1.) Dust figures.
- (2.) Breath figures.

Figures, Lichtenberg's Dust — — Figures produced by writing on a sheet of shellac with the knob of a charged Leyden jar and then sprinkling over the sheet dried and powdered sulphur and red lead, which have

been previously mixed together, and are so rendered, respectively negative and positive.

The red lead collects on the negative parts of the shellac surface, and the sulphur on the positive parts, in curious figures, known as *Lichtenberg's Dust Figures*, one of which is shown in Fig. 254.

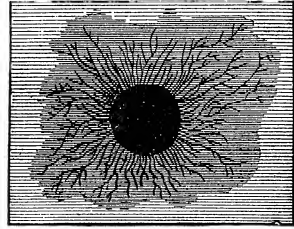

Fig. 254. *Lichtenberg's Dust Figures.*

These figures show very clearly that an electric charge tends to creep irregularly over the surface of an insulating substance.

Figures, Magnetic — —A name sometimes applied to the groupings of iron filings on a sheet of paper so held in a magnetic field as to be grouped or arranged under the influence of the lines of force of the same. (See *Field, Magnetic.*)

Filament.—A slender thread or fibre.

The term is applied generally to threads or fibres varying considerably in diameter.

Filament, Current — —A term sometimes employed in place of current streamlet. (See *Streamlets, Current.*)

Filament, Magnetic — —A polarized line or chain of ultimate magnetic particles.

This is sometimes called a *uniform magnetic filament*.

A bar-magnet possesses but two free poles. When broken at its neutral point or equator, the bar will develop free poles at the broken ends. This is explained by considering the magnet to be composed of a number of separate particles, separately magnetized. A single chain or filament of such particles is called a magnetic filament. (See *Magnet, Neutral Point of. Magnetism, Hughes' Theory of. Magnetism, Ewing's Theory of.*)

Filament of Incandescent Electric Lamp.

—(See *Lamp, Incandescent Electric, Filament of*.)

Filament, Uniform Magnetic — —A term sometimes applied to a magnetic filament. (See *Filament, Magnetic*.)

Filaments, Flashed — —Filaments for an incandescent lamp, that have been subjected to the flashing process. (See *Carbons, Flashing Process for*.)

Filamentous Armature Core.—(See *Core, Armature, Filamentous*.)

Film Cut-Out.—(See *Cut-Out, Film*.)

Finder, Induction — —A term sometimes employed for a magnetic explorer.

Finder, Position, Electric — —A device by means of which the exact position of an object can be obtained.

By means of a position-finder a gunner can be telephoned or otherwise ordered to fire at objects he cannot see, and yet obtain a fair degree of accuracy.

Finder, Range, Electric — —A device by means of which the exact distance of an enemy's ship or other target can be readily determined.

The operation of an electric range-finder is based on a method somewhat similar to the solving of a triangle for the purpose of determining distances. If the base line of a triangle and the two angles at the base are known, the other two sides and the included angle can be determined.

In the range-finder, the resistance of a German silver wire corresponds to the graduated arc of the theodolite used to measure the angles, and a rheostat, as a receiving instrument, measures the values of the angles. The base line is a constant, so that the receiving instrument is marked in yards instead of angles. To use the range-finder, two observers watch the target object continuously through a telescope. They do this and nothing else, while a third observer watches a galvanometer and so alters a resistance, by moving a contact or slide key along a resistance wire, as to keep the needle of the galvanometer constantly at zero. The exact distance being thus ascertained, the gunner can make the proper allowance in firing.

Finder, Wire — —Any form of galvanometer used to locate or find the corre-

sponding ends of different wires in a bunched cable.

The different wires in a cable are usually tagged and numbered at the end of the cable and at the joints. The telephone has been successfully employed as a wire finder.

Fire Alarm Annunciator.—(See *Annunciator, Fire Alarm*.)

Fire Alarm, Automatic — —(See *Alarm, Fire, Automatic*.)

Fire Alarm Contact.—(See *Contact, Fire Alarm*.)

Fire Alarm Signal Box.—(See *Box, Fire Alarm Signal*.)

Fire Alarm Telegraph Box.—(See *Box, Fire Alarm Telegraph*.)

Fire Ball.—(See *Ball, Fire*.)

Fire Cleansing.—(See *Cleansing, Fire*.)

Fire Extinguisher, Electric — —A thermostat or mercury contact, which automatically completes a circuit and turns on a water supply for extinguishing a fire, on a certain predetermined increase of temperature.

Fire, Hot, St. Elmo's — —A term proposed by Tesla for a form of powerful brush discharge between the secondary terminals of a high frequency induction coil. (See *Discharge, Brush-and-Spray*.)

This form of St. Elmo's fire differs from the ordinary form in being hot. Its general appearance is shown in Fig. 255, taken from Tesla.

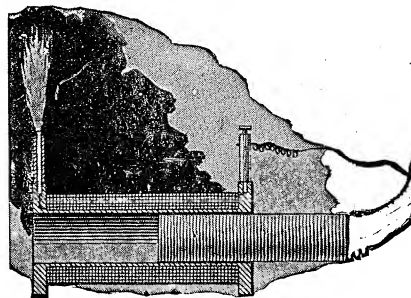

Fig. 255. St. Elmo's Hot Fire.

Describing its production he says: "In many of these experiments, when powerful effects are wanted for a short time, it is advantageous to use

iron cores with the primaries. In such case a very large primary coil may be wound and placed side by side with the secondary, and, the nearest terminal of the latter being connected to the primary, a laminated iron core is introduced through the primary into the secondary as far as the streams will permit. Under these conditions an excessively powerful brush, several inches long, which may be appropriately called 'St. Elmo's hot fire,' may be caused to appear at the other terminal of the secondary, producing striking effects. It is a most powerful ozonizer; so powerful indeed, that only a few minutes are sufficient to fill the whole room with the smell of ozone, and it undoubtedly possesses the quality of exciting chemical affinities."

Fire, St. Elmo's — — Tongues of faintly luminous fire which sometimes appear on the pointed ends of bodies in connection with the earth, such as the tops of church steeples or the masts of ships.

The appearance of the St. Elmo's fire is due to brush discharges of electricity.

Fishes, Electric — — A term applied to various fishes, such as the eel and the ray, which possess the ability of protecting themselves by giving electric shocks to objects touching them. (See *Eel, Electric*.)

Fishing Box.—(See *Box, Fishing*.)

Fittings or Fixtures, Electric Light — — The sockets, holders, arms, etc., required for holding or supporting incandescent electric lamps.

Fixed Secondary. — (See *Secondary, Fixed*.)

Fixtures, Telegraphic — — A term generally limited to the variously shaped supports provided for the attachment of telegraphic wires.

Fixtures, Telegraphic House-Top — — Telegraphic fixtures placed on the roofs of buildings for the support of the lines.

Flaming Discharge. — (See *Discharge, Flaming*.)

Flash, Side — — A sparking or lateral discharge taking place from the sides of a conductor, when an impulsive rush of electricity passes through it.

The phenomenon of side flashing is due to a lateral discharge which takes the alternative path, instead of a path of much smaller ohmic resistance. The tendency to side flash results from the fact that the metallic circuit possesses inductance. (See *Path, Alternative. Discharge, Lateral. Inductance*.)

Flashed Carbons. — (See *Carbons, Flashed*.)

Flashed Filaments. — (See *Filaments, Flashed*.)

Flashes, Auroral — — Sudden variations in the intensity of the auroral light.

Intermittent flashes of auroral light that occur during the prevalence of an aurora. (See *Aurora Borealis*.)

Flashing of Carbons, Process for the — — (See *Carbons, Flashing Process for*.)

Flashing of Dynamo-Electric Machine.— (See *Machine, Dynamo-Electric, Flashing of*.)

Flat Cable.—(See *Cable, Flat*.)

Flat Duplex Cable.—(See *Cable, Flat Duplex*.)

Flat Ring Armature.—(See *Armature, Flat Ring*.)

Flats.—A name sometimes applied to those parts of commutator segments the surface of which, through wear, has become lower than the other portions. (See *Commutator*.)

Fleming's Gauss.—(See *Gauss, Fleming's*.)

Fleming's Standard Voltaic Cell.—(See *Cell, Voltaic, Standard, Fleming's*.)

Flexible Electric Light Pendant.—(See *Pendant, Flexible Electric Light*.)

Flexible Lead.—(See *Lead, Flexible*.)

Floating Battery, De la Rive's.—(See *Battery, Floating, De la Rive's*.)

Flow.—In hydraulics, the quantity of water or other fluid which escapes from an orifice in a containing vessel, or through a pipe, in a given time.

Flow-Lines of Escaping Fluid.—Lines within the mass of a fluid in motion, drawn at

a number of points, so that the flow at any instant is tangential at such points to the curved path.

Flow, Magnetic — —The magnetic flux. (See *Flux, Magnetic*.)

Flow of Current, Assumed Direction of — —(See *Current, Assumed Direction of Flow of*.)

Flow of Energy.—(See *Energy, Flow of*.)

Flow of Lines of Electrostatic Force.—(See *Force, Electrostatic, Lines of, Assumed Flow of*.)

Flow of Magnetic Induction.—(See *Induction, Magnetic, Flux or Flow of*.)

Fluid, Depolarizing — —An electrolytic fluid in a voltaic cell that prevents polarization. (See *Cell, Voltaic, Polarization of*.)

Fluid Insulator.—(See *Insulator, Fluid*.)

Fluoresce.— To become self-luminous when exposed to light.

A body is said to fluoresce when it shines, by means of the light it produces. In this respect it differs from an illumined body, which shines by reflected light.

Fluorescence.—A property possessed by certain solid or liquid substances of becoming self-luminous while exposed to light.

In fluorescence the refrangibility of rays of light is changed. The invisible rays beyond the violet, the ultra-violet, become visible, so that the light is transformed, the particles absorbing one wave length and emitting another. (See *IncanDESCENCE*.)

Canary glass, or glass colored yellow by oxide of uranium, or a solution of sulphate of quinine, possesses fluorescent properties. The path of a pencil of light brought to a focus in either of these substances, or a beam or cone of light passed through them, is rendered visible by the particles lying in this path becoming self-luminous. The path of a beam of light entering the dusty air of a darkened chamber is visible from the light being diffused or scattered in all directions by the floating dust particles.

In a fluorescent substance, the path of the light is also rendered visible by the particles which lie in its path, throwing out light in all directions. There is, however, this difference, that in the

case of the dust particles the light which comes directly from the beam is reflected; while in the case of the fluorescent body the light comes from the particles themselves, which are set into vibration by the light that is passing through, and has been absorbed by their mass.

Fluorescence is, therefore, a variety of phosphorescence. (See *Phosphorescence*.)

Fluorescent.—Possessing the capability of fluorescing.

Fluorescing.—Exhibiting the property of fluorescence.

Flush Box.—(See *Box, Flush*.)

Fluviograph.—An apparatus for electrically registering the varying height of water in a tidal stream or in the ocean; or, in general, differences of water levels.

Flux, Magnetic — —The number of lines of magnetic force that pass or flow through a magnetic circuit.

The total number of lines of magnetic force in any magnetic field.

The magnetic flux is also called the magnetic flow.

A Committee of the American Institute of Electrical Engineers on "Units and Standards" proposed the following as the definition of magnetic flux.

"The magnetic flux through a surface bounded by a closed curve is the surface integral of magnetic induction taken over the bounded surface, and when produced by a current is also equal to the line integral of the vector potential of the current taken round the boundary."

"The uniform and unit time rate of change in flux through a closed electric circuit establishes unit electromotive force in the circuit."

Fluxes range in present practical work from 100 to 100,000,000 C. G. S. lines, and the working units would perhaps prefix milli- and micro-

Flux of Magnetic Induction.—(See *Induction, Magnetic, Flux or Flow of*.)

Flux or Flow of Magnetism.—(See *Magnetism, Flux or Flow of*.)

Fly, Electric — —A wheel or other device driven by the reaction of a convective discharge. (See *Flyer, Electric, Convection, Electric*.)

Flyer, Electric — — A wheel arranged so as to be set into rotation by the escape of convection streams from its points when connected with a charged conductor.

A wheel formed of light radial arms P, P, P, etc., shaped as shown in Fig. 256, and capable of rotation on the vertical axis A, is set into rapid rotation when connected with the prime conductor of a frictional or influence machine, through the convection streams of air particles, which are shot off from the points or extremities of the radial arms. The wheel is driven by the reaction of these streams in a direction opposite to that of their escape. (See *Discharge, Convective.*)

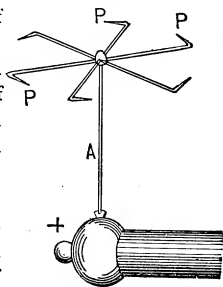

Fig. 256. Electric Flyer.

Focus.—A point in front or back of a lens or mirror, where all the rays of light meet or seem to meet. (See *Lens, Achromatic.*)

Fog, Electric — — A dense fog which occurs on rare occasions when there is an unusual quantity of free electricity in the atmosphere.

During these electric fogs the free electricity of the atmosphere changes its polarity at frequent intervals.

Following Horn of Pole Pieces of Dynamo-Electric Machine.—(See *Horns, Following, of Pole Pieces of a Dynamo-Electric Machine.*)

Foot-Candle.—(See *Candle, Foot.*)

Foot-Pound.—A unit of work. (See *Work.*)

The amount of work required to raise 1 pound vertically through a distance of 1 foot.

The same amount of work, viz., 3 foot-pounds, is done by raising 1 pound through a vertical distance of 3 feet, or 3 pounds through a vertical distance of 1 foot.

Apart from air friction, the amount of work done in raising 1 pound through 1 foot, viz., 1 foot-pound, is the same whether this work be done in one second or in one day. The *power*, or the *rate of doing work*, is, however, very different in the two cases. (See *Power.*)

Force.—Any cause which changes or tends

to change the condition of rest or motion of a body.

Force, Centrifugal — — The force that is supposed to urge a rotating body directly away from the centre of rotation.

If a stone be tied to a string and whirled around, and the string break, the stone will not fly off directly away from the centre, but will move along the tangent to the point where it was when the string broke.

The centrifugal force in reality is the force which is represented by the tension to which the string is subjected during this rotation.

Force, Coercive — — A name sometimes applied to coercive force. (See *Force, Coercive.*)

Force, Coercive — — The power of resisting magnetization or demagnetization.

Coercive force, in the sense of resisting demagnetization, is sometimes called *magnetic retentivity*.

Hardened steel possesses great coercive force; that is, it is magnetized or demagnetized with difficulty.

Soft iron possesses very feeble coercive force.

It is on account of the feeble coercive force of the soft iron core of an electro-magnet that its main value depends, since it is thereby enabled to rapidly acquire its magnetization, on the completion of a circuit through its coils, and to rapidly lose its magnetization on the opening of such circuit.

Force, Contact — — A difference of electrostatic potential, produced by the contact of dissimilar metals.

That a difference of potential is produced by the mere contact of dissimilar metals is now generally recognized. Such a force is generally called the true contact force. (See *Force, True Contact.*)

According to Lodge, a true contact force has no existence. There is no evidence, he thinks, of a peculiar electromotive force at the point of contact, but that the phenomena are due simply to the fact that the metals are immersed in air or oxygen, which is capable of combining with one of them, and that, therefore, the cause of the phenomena is the greater action, for instance, of the oxygen of the air on the zinc than on the copper.

According to this view, the voltaic effect is due not to the difference of potential between the zinc and copper, but to the difference of the action of the air or moisture.

Force de Cheval or Cheval Vapeur.—The French term for horse-power.

The force de cheval is equal to 75 kilogramme-metres per second, or 32,549 foot-pounds per minute.

The English horse-power is equal to 33,000 foot-pounds per minute. 1 force de cheval equals .98634 horse-power; 1 horse-power equals 1.01385 force de cheval.—(*Hering.*)

Force, Electric — — The force developed by electricity.

This term is generally limited to the force of attraction or repulsion produced by an electrostatic charge.

Force, Electromotive — — The force starting electricity in motion, or tending to start electricity in motion.

The force which moves or tends to move electricity.

The term is an unfortunate one. Strictly speaking, electromotive force is not a force at all: at least, it is not a force in the Newtonian sense, where force is only that which acts on *matter*.

The term electromotive force is generally written thus: E. M. F.

The unit of electromotive force is the volt.

When electric induction takes place, there results a change in the distribution of the thing called electricity, whereby a movement occurs that results in a positive and a negative charge. The cause which produces this movement is called the electromotive force.

There is an unfortunate want of uniformity at present in the use of the term "electromotive force." By some, the electromotive force is regarded as something which causes the difference of potential; by others the electromotive force is regarded as being produced by the difference of potential; and, by still others, electromotive force is regarded as the entire electric moving cause produced by any source; while anything less than this is called by them potential difference.

Those who regard the electromotive force as the cause which produces the potential difference look on the electromotive force as acting within

the source and maintaining a potential difference at its terminals.

Silvanus P. Thompson uses the term electromotive force in his "Elementary Lessons in Electricity and Magnetism" as follows: "The term 'electromotive force' is employed to denote that which moves or tends to move electricity from one place to another. For brevity we sometimes write it E. M. F. In this particular case it is obviously the result of difference of potential and proportional to it; just as in water pipes, a difference in level produces a pressure, and the pressure produces a flow as soon as the tap is turned on, so difference of potential produces electromotive force, and electromotive force sets up a current as soon as a circuit is completed for the electricity to flow through."

Mascart and Joubert, in their work on "Electricity and Magnetism," Vol. I., say: "In all cases the difference of potential $V_1 - V_2$, may be considered as producing the motion of electrical masses; it is often called the electromotive force."

Maxwell, in his "Elementary Treatise on Electricity," speaking of the potential differences which may be shown to exist at the terminals of a Daniell voltaic cell when on open circuit, says: "This difference of potential is called the electromotive force of a Daniell cell."

Balfour Stewart, in his "Electricity and Magnetism," says: "This difference of electric level we shall call E, and, indeed, it is merely a manner of expressing the cause of electromotive force."

Prof. Fleming, in his "Short Lectures to Electrical Artisans," says: "The difference of electrical level or potential must be caused by some electromotive force acting in the conductor."

Prof. Anthony, in "A Review of Modern Electrical Theories," regards the potential difference as due to electromotive force. He says: "Difference of potential results from a changed electrical distribution, an electrical strain, and represents the tendency to return to the state of equilibrium. Electromotive force is the something from without that produced the electric strain."

Hering, in his "Principles of Dynamo-Electric Machines," says: "Difference of potential is, as the name implies, the difference of electrical potential between any two points of a circuit, and may, therefore, be applied to that at the poles of a machine, battery or lamp, or at the ends of leads, or, in general, to any two points in a circuit. The term 'electromotive force,' however,

applies only to the maximum difference of potential which exists in the circuit, or, in other words, the total generated difference of potential."

This last paragraph expresses the distinction between the two terms as ordinarily used in connection with dynamos and batteries.

Force, Electromotive, Absolute Unit of

— —A unit of electromotive force expressed in absolute or C. G. S. units.

The one-hundred millionth part of a volt, since 1 volt equals 10^8 C. G. S. units of electromotive force. (See *Units, Practical*.)

Force, Electromotive, Average or Mean

— —The sum of the values of a number of separate electromotive forces divided by their number.

The square root of the mean square of the electromotive force of an alternating or variable current.

When a wire in the armature of a dynamo-electric machine cuts the lines of magnetic force in the field of the machine, the electromotive force produced depends on the number of lines of force cut per second. This will vary for different positions of the coil. The mean value of the varying electromotive forces between the brushes is the average electromotive force.

Force, Electromotive, Back — —A term sometimes used for counter electromotive force.

Counter electromotive force is the preferable term. (See *Force, Electromotive, Counter*.)

Force, Electromotive, Counter — —

An opposed or reverse electromotive force, which tends to cause a current in the opposite direction to that actually produced by the source.

In an electric motor, an electromotive force contrary to that produced by the current which drives the motor, and which is proportional to the velocity attained by the motor.

Counter electromotive force acts to diminish the current in the same manner as a resistance would, and is therefore sometimes called *spurious resistance* in order to distinguish it from an *ohmic* or *true resistance*.

Counter electromotive force is sometimes expressed in ohms, though it is not a *true ohmic resistance*. (See *Resistance, Spurious*.)

The counter electromotive force of a voltaic battery is due to the *polarization* of the cells. Since this force is due to the current in the cell, it can never exceed such current or reverse its direction. It may, however, equal it and thus stop its flow. (See *Cell, Voltaic, Polarization of*.)

In a *storage cell*, the charging current produces an electromotive force counter to itself, which, as in a motor, is a true measure of the energy stored in the cell. Economy requires that the electromotive force of the charging current should be as little as possible greater than that of the counter electromotive force of the cell it is charging.

In a voltaic arc a counter electromotive force is believed to be set up by polarization.

Force, Electromotive, Counter, of Convective Discharge — —

Resistance to the passage of an electric discharge through a high vacuum, somewhat of the nature of a counter electromotive force.

The resistance to the passage of convective discharges, therefore, is due to the following causes:

- (1.) True ohmic resistance.
- (2.) Counter electromotive force.

Force, Electromotive, Counter, of Mutual Induction — —

The counter electromotive force produced by the mutual induction of the primary and secondary circuits on each other.

Force, Electromotive, Counter, of Self-Induction — —

That part of the impressed electromotive force which is producing, or which tends to produce, at any instant a change in the current strength.

Force, Electromotive, Counter, of Self-Induction of the Primary — —

A counter electromotive force produced in the primary circuit of an induction coil by the action thereon of a simple periodic electromotive force.

The counter electromotive force produced in the primary circuit of an induction coil by the application of a simple periodic impressed electromotive force to the primary circuit.

Force, Electromotive, Counter, of Self-Induction of the Secondary — —

A counter electromotive force produced in the secondary by the periodic variations in the effective electromotive force in the secondary.

Force, Electromotive, Direct — — An electromotive force acting in the same direction as another electromotive force already existing.

The term direct electromotive force is employed in contradistinction to counter electromotive force. (See *Force, Electromotive, Counter.*)

Force, Electromotive, Effective — — The difference between the direct and the counter electromotive force.

Force, Electromotive, Effective, of Secondary — — The difference between the direct and the counter electromotive force in the secondary of an induction coil.

Force, Electromotive, Generated by Dynamo-Electric Machine, Method of Increasing — — The electromotive force of a dynamo-electric machine may be increased in the following ways, viz :

- (1.) By increasing its speed of rotation.
- (2.) By increasing the strength of the magnetic field in which the armature rotates.
- (3.) By increasing the size of the field through which the armature passes in unit time, the intensity remaining the same.
- (4.) By increasing the number of armature windings, *i. e.*, by making successive parts of the same wire pass simultaneously through the field.

Force, Electromotive, Impressed — — The electromotive force acting on any circuit to produce a current therein.

The impressed electromotive force may be regarded as producing two parts, viz. : The effective electromotive force and the counter electromotive force.

Force, Electromotive, Inductive — — A term sometimes used in place of counter electromotive force of self-induction.

Force, Electromotive, Inverse — — An electromotive force which acts in the opposite direction to another electromotive force already existing. (See *Force, Electromotive, Counter.*)

Force, Electromotive, Motor — — A term proposed by F. J. Sprague for the counter electromotive force of an electric motor. (See *Force, Electromotive, Counter.*)

This term was proposed by Sprague as express-

ing the necessity for the existence of a counter electromotive force in an electric motor, in order to permit it to utilize the energy of the electric current which drives it.

Force, Electromotive, of Induction — — The electromotive force developed by any inductive action.

In a coil of wire undergoing induction, the value of the induced electromotive force does not depend in any manner on the nature of the material of which the coil is composed.

It has been shown:

(1.) That the electromotive force of induction is independent of the width, thickness or material of the wire windings.—(*Faraday.*)

(2.) That it is dependent on the form of the conductor, and the character of the change it experiences as regards the magnetic induction which takes place through it.

Since any increase in the strength of a current flowing through a coiled circuit, produces a counter electromotive force, which opposes the electromotive force producing the current, it is clear that the impressed electromotive force must do work against this counter electromotive force all the time the current strength is increasing.

The movement of a circuit of a given length through a given field with a given velocity produces the same electromotive force whether the circuit be formed of conducting material or non-conducting material, or consists of an electrolyte.

Force, Electromotive, of Secondary or Storage Cell, Time-Fall of — — A gradual decrease in the potential difference of a storage battery observed during the discharge of the same.

When a secondary or storage battery is first discharged, a slight decrease of its potential difference takes place and a potential difference of a slightly decreased value is maintained nearly constant during a protracted period of discharge.

Force, Electromotive, of Secondary or Storage Cell, Time-Rise of — — A gradual increase in the potential difference of a secondary or storage cell observed on beginning the discharge after a prolonged rest.

When a secondary or storage cell is discharged and then given a prolonged rest by opening its circuit, a gradual but decided rise in its potential difference is observed on again beginning its discharge.

Force, Electromotive, Photo — — An electromotive force produced by the action of light on selenium. (See *Cell, Selenium*.)

Force, Electromotive, Reacting Inductive, of the Primary Circuit — — The back or counter electromotive force produced in the primary circuit by the current set up by induction in the secondary.

Force, Electromotive, Secondary Impressed — — An electromotive force produced in the secondary coil or circuit by a periodic electromotive force impressed on the primary.

Force, Electromotive, Simple-Periodic — — An electromotive force which varies in such manner as to produce a simple periodic current, or an electromotive force the variations of which can be correctly represented by a simple-periodic curve.

Force, Electromotive, Thermo — — An electromotive force, or difference of potential, produced by differences of temperature acting at thermo-electric junctions.

Force, Electromotive, Transverse — — An electromotive force excited by a magnetic field in a substance in which electric displacement is occurring.

It is to a transverse electromotive force that the Hall effect is due. (See *Effect, Hall*.)

Force, Electromotive, Zigzag — — An electromotive force, the curve of which would have the general form of a zigzag.

Force, Electrostatic — — The force producing the attractions or repulsions of charged bodies.

Force, Electrostatic, Lines of — — Lines of force produced in the neighborhood of a charged body by the presence of the charge.

Lines extending in the direction in which the force of electrostatic attraction or repulsion acts.

An insulated charged conductor produces around it an electrostatic field, in a manner somewhat similar to the magnetic field produced by a magnet or an electric current. (See *Field, Electrostatic*.)

Lines of electrostatic force pass through dielectrics. Whether the force acts to produce electrostatic induction, by means of a polarization of the dielectric, or by means of a tension set up in the substance of the dielectric, is not known.

Force, Electrostatic, Lines of, Assumed Flow of — — A mathematical conception in which the phenomena of electricity are compared with the similar phenomena of heat.

In heat no flow of heat occurs over isothermal surfaces, or surfaces at the same temperature. Between different isothermal surfaces, the flow will vary with the power of heat conduction. In electricity, no flow occurs over equipotential surfaces. Specific inductive capacity corresponds to heat conductivity; and the lines of force to the lines of heat conduction. (See *Capacity, Specific Inductive*.)

Force, Lines of, Contraction of — — A decrease that occurs in the length of the circular lines of force that surround a circuit through which an electric current is passing, while the current is decreasing in intensity or strength.

The contraction or decrease in the average diameter of the circular lines of force of an electric circuit is similar to the expansion or growth of lines of force, excepting that the movement is one of decrease in diameter, and takes place in the opposite direction, *i. e.*, towards the circuit, instead of away from it. (See *Force, Lines of, Growth or Expansion of*.)

Force, Lines of, Cutting — — Passing a conductor through lines of magnetic force, so as to cut or intersect them.

The cutting of lines of magnetic force produces differences of potential. This is true whether the conductor moves through a stationary field or whether the field itself moves through the stationary conductor, so that the lines of force and the conductor cut one another. This cutting is mutual. Each line of force cuts and is cut by the circuit. Since all lines of force form closed-circuits or paths, the cutting of the circuit by the lines of force, or the reverse, forms a link or chain, and the cutting takes place at the moment of linking or unlinking, *i. e.*, of cutting.

Force, Lines of, Diffusion of — — The deflection of the lines of magnetic force from

their ordinary position, between the poles that produce them.

Force, Lines of, Direction of — —The direction in which it is assumed that the lines of magnetic force pass.

It is generally agreed to consider the lines of magnetic force as coming out of the north pole of a magnet and passing into its south pole, as shown in Fig. 257.

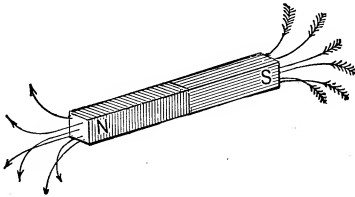

Fig. 257. Direction of Lines of Force.

This is sometimes called the positive direction of the lines of force and agrees in general with the direction in which the electric current is assumed to flow, which is from the positive to the negative. That is to say, the lines of magnetic force are assumed to flow or pass out of the north pole and into the south pole of a magnet. Of course there is no direct evidence of any flow, or of any particular direction characterizing the lines of force. (See *Field, Magnetic.*)

The lines of electrostatic force are assumed to pass out of a positively charged surface and into a negatively charged surface.

Force, Lines of, Growth or Expansion of — —The increase in the length of path through which lines of force pass, consequent on an increase in the strength of the magnetization of a magnet, or on an increase in the strength of the magnetizing current.

The circular lines of force which surround a conductor through which a current is flowing, may be regarded as starting from the surface of the conductor and growing in size as they spread outwards, at the same time new lines of force being formed in their places. This action continues while the strength of the current is increasing, somewhat like the series of concentric waves which are formed on the surface of water, when a stone is dropped into it.

In their growth or expansion outwards from the conductor, if the lines of force cut or pass through neighboring conductors, they produce

therein differences of electric potential, capable, on being connected by a conductor, of producing electric currents.

Force, Lines of, Radiation of — —The passing of lines of force out of the north pole of a magnet or solenoid.

In gross matter all lines of magnetic induction either pass through magnetized iron, or other paramagnetic substance which surrounds an electric circuit. Since lines of force pass through a vacuum, the ether which occupies such a space must also be regarded as permitting the passage of lines of force.

Force, Loops of — —A term sometimes employed in the sense of lines of force. (See *Force, Magnetic, Lines of.*)

The term "Lines of Force" is generally adopted in place of Faraday's term "Loops of Force."

Force, Magnetic — —The force which causes the attractions or repulsions of magnetic poles.

Force, Magnetic, Line of — —Arbitrarily a single line of magnetic force.

Practically the lines of magnetic force which pass through a unit area of cross-section of a magnetic field of unit strength.

Force, Magnetic, Lines of — —Lines extending in the direction in which the magnetic force acts.

Lines extending in the direction in which the force of magnetic attraction or repulsion acts. (See *Field, Magnetic.*)

Faraday regarded the lines of magnetic force as possessing tension along one direction. Lines of force act as if they were stretched elastic threads, possessed of the property of lengthening or shortening, and of repelling one another.

Force, Magnetic, Lines of, Conducting Power for — —A term employed by Faraday for magnetic permeability. (See *Permeability, Magnetic.*)

Force, Magnetic, Lines of, Positive Direction of — —The direction in which a free north-seeking pole would move along the lines of force when placed in a magnetic field.

Force, Magnetic, Tellurid — —The earth's magnetic force.

Force, Magneto-Motive — —The force that moves or drives the lines of magnetic force through a magnetic circuit against the magnetic resistance.

A Committee of the American Institute of Electrical Engineers on "Units and Standards" proposed the following definition.

The magneto-motive force in a magnetic circuit is 4π multiplied by the flow of the current linked with that circuit. The magneto-motive force between two points connected by a line is the line integral of the magnetic force along that line. Difference of magnetic potential constitutes magneto-motive force."

The same committee gave the electro-magnetic dimensional formula $L^{\frac{1}{2}} M^{\frac{1}{2}} T^{-1}$.

The flow or flux of lines of magnetic force in any magnetic circuit is proportional to the magneto-motive force divided by the magnetic resistance; or, expressing the law in the form of Ohm's law for current:

$$\text{Magnetic Flux} = \frac{\text{Magneto-Motive Force}}{\text{Reluctance.}}$$

In this formula the word reluctance is used in place of magnetic resistance. In the case of an electro-magnet, the magneto-motive force is proportional to the strength of the current which flows and the number of times it circulates; or, more simply, is proportional to the number of ampère turns. (See *Turns, Ampère*.)

Force, Magneto-Motive, Absolute Unit of — — 4π multiplied by unit current of one turn.

Force, Magneto-Motive, Practical Unit of — —A value of the magneto-motive force equal to 4π multiplied by the ampères of one turn, or to $\frac{1}{10}$ of the absolute unit.

Force, Motor Electromotive — —A term proposed by F. J. Sprague for the counter electromotive force of a motor.

During the rotation of the armature of an electric motor in its field, a counter electromotive force is produced in its coils, which acts as a spurious resistance and opposes the flow or passage of the driving current through its coils. As the speed of the motor increases, this counter electromotive force increases and the strength of the driving current decreases until a certain

maximum speed is reached, when, theoretically, no current passes.

When a load is placed on the electric motor, the speed, and consequently the counter electromotive force, is decreased and more driving current is permitted to pass. It was this consideration, viz.: that the load automatically regulates the current required to drive the motor, that led to the name motor-electromotive force. (See *Force, Electromotive, Counter*.)

Force, Resolution of — —The separation of a single force, acting with a given intensity in a given direction, into a number of separate forces acting in some other direction.

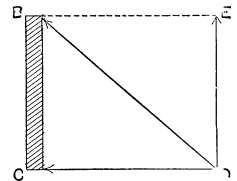

Fig. 258. Resolution of Force.

Thus the force D B, Fig. 258, acting with the intensity and in the direction shown, may be resolved into two component forces, D E and D C, acting in the directions and having the intensities shown. The single force D B, has been resolved into two separate forces D E and C D.

Force, True Contact — —A force or effect entirely distinct from the voltaic effect, which exists at the points of contact between two dissimilar metals.

The truth of the existence of a true contact force at the junction of dissimilar metals is seen by the reversible heat effects observed, when a current of electricity is passed across a junction of two dissimilar metals. When the current is passed in one direction, an increase of temperature is produced, but when passed in the opposite direction, a decrease of temperature. (See *Effect, Peltier*.)

Hence there would appear to be a force existing at the junction, helping the electricity along in one direction, but opposing it in the opposite direction. In one direction the electricity does work and consumes its own energy in so doing. In the other direction it opposes the passage of the current, and there results a generation of heat.

Force, Tubes of — —Tubes bounded by lines of electrostatic or magnetic force.

Lines of force never intersect one another. Hence a tube of force may be regarded as con-

taining the same number of lines of force at any and every cross-section.

Tubes of electrostatic force always terminate against equal quantities of positive and negative electricity respectively. They terminate when they meet a conducting surface.

The term tubes of force is somewhat misleading, since such so-called tubes are in general cones rather than tubes.

Force, Twisting — —A term sometimes used for torque. (See *Torque*.)

Force, Unit of — —A force which, acting for one second on a mass of one gramme, will give it a velocity of one centimetre per second.

Such a unit of force is called a dyne. (See *Dyne*.)

Forces, Composition of — —Finding the direction and intensity of a single force which represents the total effect of two or more forces acting simultaneously on a body. (See *Component*.)

Forces, Parallelogram of — —A parallelogram constructed about the two lines that represent the direction and intensity with which two forces are simultaneously acting on a body, in order to determine the direction and intensity of the resultant force with which it moves.

If the two forces A C and A B, Fig. 259, simultaneously act in the direction of the arrows on a body at A, the direction and intensity of the resultant A D, is determined by drawing C D and B D, parallel respectively to A B and A C. The diagonal A D, of the parallelogram A C D B, thus produced, gives this resultant. (See *Component*.)

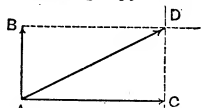

Fig. 259. Parallelogram of Forces.

Fork, Trolley — —The mechanism which mechanically connects the trolley wheel to the trolley pole. (See *Trolley*.)

Forked Circuits.—(See *Circuits, Forked*.)

Forked Lightning.—(See *Lightning, Forked*.)

Formal Inductance of Circuit.—(See *Inductance, Formal, of Circuit*.)

Forming Plates of Secondary or Storage Cells.—(See *Plates of Secondary or Storage Cells, Forming of*.)

Formulae.—Mathematical expressions for some general rule, law, or principle.

Formulae are of great assistance in science in expressing the relations which exist between certain forces or values, and the effects that result from their operations, since they enable us to express these relations in clear and concise forms.

Thus in the formulation of Ohm's law:

$$C = \frac{E}{R}$$

we see that the continuous current C, in any circuit, is equal to the electromotive force E, divided by the resistance R. Again, we see that the current is directly proportional to the electromotive force, and inversely proportional to the resistance.

Formulae are usually written in the form of an equation and therefore contain the sign of equality or =.

Formulae, Photometric — —(See *Photometric Formulae*.)

Foucault Currents.—(See *Currents, Foucault*.)

Four-Way Splice Box.—(See *Box, Splice, Four-Way*.)

Frames, Sectional Plating — —Frames employed for so holding the objects to be plated that they shall receive a greater depth of deposit on certain portions of their surface than elsewhere.

Sectional printing frames depend for their action on the fact that the portions receiving the greater depth of deposit are nearer one of the electrodes than the rest of the surface.

Franklinic Electricity.—(See *Electricity, Franklinic*.)

Franklinization.—Electrization by means of a frictional or influence machine as distinguished from faradization or electrization by means of an induction coil.

This term is used only in medical electricity.

Free Charge.—(See *Charge, Free*.)

Free Magnetic Pole.—(See *Pole, Magnetic, Free*.)

Frequency of Alternations.—(See *Alternations, Frequency of*.)

Friction Brake.—(See *Brake, Friction.*)

Frictional Electrical Machine.—(See *Machine, Frictional Electric.*)

Frictional Electricity.—(See *Electricity, Frictional.*)

Frog, Galvanoscopic — — The hind legs of a recently killed frog employed as an electroscope or galvanoscope, by sending an electric current from the nerves to the muscles. (See *Electroscope.*)

In 1786, Luigi Galvani made the observation that when the legs of a recently killed frog were touched by a metallic conductor connecting the nerves with the muscles, the legs were convulsed as though alive. He repeated this experiment and found the movements were more pronounced when two dissimilar metals, such as iron and copper, were employed in the manner shown in Fig. 260.

The classic experiment created intense excitement in the scientific world, and Galvani at first believed that he had discovered the true vital fluid of the animal, but afterwards recognized it as electricity, which he believed to be obtained from the body of the animal. Volta claimed that the movements were due to electricity caused by the contact of dissimilar metals, and thus produced his famous voltaic pile. (See *Pile, Voltaic.*)

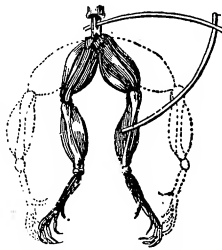

Fig. 260. Galvanoscopic Frog.

Frog, Trolley — — The name given to the device employed in fastening or holding together the trolley wires at any point where the trolley wire branches, and properly guiding the trolley wheel along the trolley wire on the movement of the car over the track.

Frog, Trolley, Right-Hand — — A trolley frog used at the point where the branch trolley wire leaves the main line on the right of the direction in which the car is moving.

Frog Trolley, Standard — — The trolley frog used at the point where two branch lines make equally converging angles to the main line.

Frog, Trolley, Three-Way — — A trolley

frog used where the line branches in three directions.

Frying of Arc.—(See *Arc, Frying of.*)

Fulgurite.—A tube of vitrified sand, believed to be formed by a bolt of lightning.

The fulgurite consists of an irregular shaped tube of glass formed of sand which has been melted by the electric discharge.

Full Contact.—(See *Contact, Metallic.*)

Fuller's Mercury Bichromate Voltaic Cell.—(See *Cell, Voltaic, Fuller's Mercury Bichromate.*)

Fulminate.—The name of a class of highly explosive compounds.

Fulminating gold, silver and mercury are highly explosive substances. Fulminates are employed in percussion caps.

Function, Trigonometrical — — Certain quantities, the values of which are dependent on the length of the arcs subtended by angles, which are taken for the measures of the arcs or angles instead of the arcs themselves.

The trigonometrical functions are the sine, the co-sine, the tangent, the co-tangent, the secant and the co-secant.

These are generally abbreviated thus, viz.: sin., cos., tan., cot., sec. and co-sec.

The sine of an angle or arc is the perpendicular distance from one extremity of the arc to the diameter passing through the other extremity.

Thus in Fig. 261 B D, is the sine of the angle B O A, or of the arc, B A.

The co-sine of an angle or arc is that part of

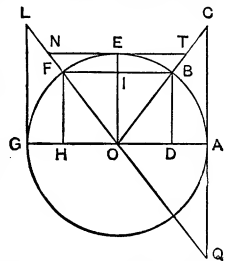

Fig. 261. Trigonometrical Functions.

between the foot of the sine and the centre. Thus, D O, is the co-sine of the angle B O A, or of the arc B A.

The co-sine of an arc is equal to the sine of its complement. Thus E O B, or B E, the complement of B A, has for its sine I B, which is equal to O D. (See *Angle, Complement of.*)

If the arc is greater than a right angle, or 90

degrees, such, for instance, as the angle $T O G$, or the arc $B E F G$, $B D$, is its sine. This is also the sine of $B O A$, or $B A$, which is the supplement of $T O G$, or $B E F G$. Hence the sine of an arc is equal to the sine of its supplement.

The same is true of the co-sine.

The tangent of an angle or arc is a straight line touching the arc at one extremity, drawn perpendicular to the diameter at that end of the arc, and limited by a straight line connecting the centre of the circle and the other end of the arc. Thus $C A$, is the tangent of the angle $B O A$, or the arc $B A$.

The co-tangent of an angle or arc is equal to the tangent of its complement. Thus $E T$, is the co-tangent of the angle $B O A$, or the arc $B A$.

The tangent of an angle or arc is equal to the tangent of its supplement. Thus $A C$, is the tangent of the angle $B O A$, or the arc $B A$. It is also equal to the tangent of the angle $B O G$, or the arc $B E F G$, the corresponding supplement of the angle $B O A$, or the arc $B A$.

The secant of an angle or arc is the straight line drawn from the centre of the circle through one extremity of the arc and limited by the tangent passing through the other extremity. Thus $O C$, is the secant of the angle $B O A$, or of the arc $B A$.

The secant of an angle or arc is equal to the secant of its supplement.

The co-secant of an angle or arc is equal to the secant of its complement.

Thus $O T$, is the co-secant of the angle $B O A$, or of the arc $B A$.

It will be observed that the co-sine, the co-tangent and the co-secant are respectively the sine, tangent and secant of the complement of the arc, or in other words, the complement-sine, the complement-tangent and the complement-secant.

Fundamental Units.—(See *Units, Fundamental*.)

Furnace, Electric — — A furnace in which heat generated electrically is employed for the purpose of effecting difficult fusions for the extraction of metals from their ores, or for other metallurgical operations.

In electric furnaces, the heat is derived either from electric incandescence or from the voltaic arc. The latter form is frequently adopted.

The substance to be treated is exposed directly

to the voltaic arc. In some forms of furnace the crushed ore is permitted to fall through the arc, and the melted matter received in a suitable vessel in which the separation of the substances so formed is afterwards completed. In other forms of furnace, the ore is placed between two electrodes of carbon or other refractory substance, between which a powerful current is passed. In the Cowles furnace, when aluminium is reduced, molten copper forms an alloy with the aluminium as soon as separated.

Very numerous applications of electricity to furnace operations have been made.

Fuse Block.—(See *Block, Fuse*.)

Fuse Board.—(See *Board, Fuse*.)

Fuse Box.—(See *Box, Fuse*.)

Fuse, Branch — — A safety fuse or strip placed in a branch circuit. (See *Fuse, Safety*.)

Fuse, Converter — — A safety fuse connected with the circuit of a converter or transformer.

Fuse, Electric — — A device for electrically igniting a charge of powder.

Electric fuses are employed both in blasting operations and for firing cannon.

Electric fuses are operated either by means of the direct spark, or by the incandescence of a thin wire placed in the circuit. They are therefore either *high tension*, or *low tension fuses*.

The advantages of an electric fuse consist in the fact that its use permits the simultaneous firing of a number of charges in a mining operation, thus obtaining a greater effect from the explosion. A fulminate of mercury is frequently employed in connection with some forms of electric fuses.

Fuse, Electric, High-Tension — — A fuse that is ignited by the heating power of an electric spark.

High-tension fuses, therefore, require a high electromotive force. This is obtained either by means of induction coils or by some form of electrostatic induction machine.

Fuse, Electric, Low-Tension — — A fuse that is ignited by heating a wire to incandescence by the passage through it of an electric current.

Fuse, Electric, Stratham's — — A form

of fuse, in which the ignition is effected by the electric spark, is shown in Fig. 262.

The spark passes through a break A B, in the insulated leads D. Since gunpowder is not readily ignited by an electric spark, a peculiar priming material is employed at A B, in the place of ordinary powder.

Fuse Links. — (See *Links, Fuse.*)

Fuse, Magazine — — A safety fuse so arranged as to readily permit the replacement of the fuse when burned out.

A spool contains a coil of fuse wire. In order to release the burned-out fuse, a wedge-shaped device is provided to open the clamps that hold the fuse strip to release the portions of burned-out fuse left, and connection with the fuse strip is severed while the attachment of the new strip is being made.

Fuse, Main — — A safety fuse or strip placed in a main circuit. (See *Fuse, Safety.*)

Fuse, Platinum — — A thin platinum wire rendered incandescent by the passage of an electric current and employed for the ignition of a charge of powder. (See *Fuse, Electric.*)

Fuse, Safety — — A strip, plate or bar of lead, or some readily fusible alloy, that automatically breaks the circuit in which it is placed on the passage of a current of suf-



Fig. 262.
Stratham's Fuse.

ficient power to fuse such strip, plate or bar, when such current would endanger the safety of other parts of the circuit.

Safety fuses are often called safety strips or safety plugs.

Safety fuses are made of alloys of lead, and are placed in boxes lined with non-combustible material in order to prevent fires from the molten metal.

Fig. 263 shows a fusible strip F, connected with leads L, L. Safety fuses are placed on all branch circuits, and are made of sizes proportionate to the number of lamps they guard.

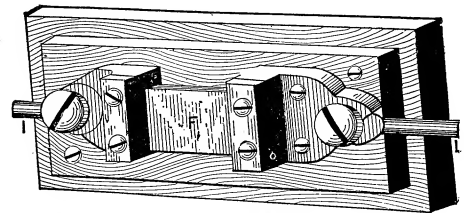

Fig. 263. *Safety Fuse.*

Since incandescent lamps are generally placed in the circuit in multiple-arc, or in multiple-series, one or more of the circuits can be opened by the fusion of the plug without interfering with the continuity of the rest of the circuits. In series circuits, however, such as arc-light circuits, when a lamp is cut out, a short circuit or path around it must be provided in order to avoid the extinguishing of the rest of the lights.

Fuse Wire.—(See *Wire, Fuse.*)

Fusible Plug.—A term commonly applied to a safety plug. (See *Fuse, Safety*)

G

Gains.—The spaces cut in the faces of telegraph poles for the support or placing of the cross arms.

Galvanic Battery.—(See *Battery, Galvanic.*)

Galvanic Cell.—(See *Cell, Voltaic.*)

Galvanic Circle.—(See *Circle, Galvanic.*)

Galvanic Circuit.—(See *Circuit, Galvanic.*)

Galvanic Dosage.—(See *Dosage, Galvanic.*)

Galvanic Electricity.—(See *Electricity, Galvanic.*)

Galvanic Excitability of Nerve or Muscular Fibre.—(See *Excitability, Electric, of Nerve or Muscular Fibre.*)

Galvanic Irritability.—(See *Irritability, Galvanic.*)

Galvanic Multiplier.—(See *Multiplier, Galvanic.*)

Galvanic Polarization.—(See *Polarization, Galvanic.*)

Galvanic Taste.—(See *Taste, Galvanic.*)

Galvanism.—A term sometimes employed to express the effects produced by voltaic electricity.

Galvanization, Central — —A variety of general galvanization in which the kathode is placed on the epigastrium and the anode moved over the body.

Galvanization, Electro-Metallurgical — —The process of covering any conductive surface with a metallic coating by electrolytic deposition, such, for example, as the thin copper coating deposited on the carbon pencils or electrodes used in systems of arc lighting.

The term is borrowed from the French, in which it has the above signification. It is preferably replaced by the term electro-plating. (See *Plating, Electro.*)

The term galvanization is never correctly applied to the process for covering iron with zinc or other metal by dipping the same in a bath of molten metal.

Galvanization, Electro-Therapeutical — —In electro-therapeutics, the effects produced on nervous or muscular tissue by the passage of a voltaic current.

Galvanization, General — —A method of applying a current therapeutically by the use of electrodes of sufficient size to direct the current through practically the entire body.

Galvanization, Labile — —A term employed in electro-therapeutics, in contradistinction to stabile galvanization, to designate the method of applying the current by keeping one electrode at rest in firm contact with one part of the body, and connecting the other electrode to a sponge which is moved over the parts of the body that are to be treated.

Galvanization, Local — —The application of galvanization to parts or organs of the body in contradistinction to general galvanization.

Galvanization, Stabile — —A term employed in electro-therapeutics in which the current is caused to pass continuously and steadily through the portions of the body undergoing galvanization.

In stabile galvanization, the current is applied to and removed from the body gradually, in order to avoid shocks at the beginning and end of the application.

Galvanized Iron.—(See *Iron, Galvanized.*)

Galvano.—A word sometimes used in France in place of the word electro, to signify an article reproduced in copper by electro-metallurgy, especially an electrotpe or wood-cut.

Galvano-Causty.—(See *Causty, Galvano.*)

Galvano-Cautery.—(See *Cautery, Galvano.*)

Galvano-Cautery, Chemical — —A term sometimes applied to electro puncture or the application of electrolysis to the treatment of diseased growths. (See *Cautery, Electric. Puncture, Electro.*)

The term chemical galvano-cautery would appear to be poorly chosen, as it would imply the existence of a cautery action, which in point of fact does not exist.

Galvano-Faradization.—In electro-therapeutics, the simultaneous excitation of a nerve or muscle by both a voltaic and a faradic current.

Galvano-Magnet.—A term sometimes used for electro-magnetic.

Electro magnetic is by far the preferable term, and is almost universally employed in the United States.

Galvanometer.—An apparatus for measuring the strength of an electric current by the deflection of a magnetic needle.

The galvanometer depends for its operation on the fact that a conductor, through which an electric current is flowing, will deflect a magnetic needle placed near it. This deflection is due to the magnetic field caused by the current. (See *Field, Magnetic, of an Electric Current.*)

This action of the current was first discovered by Oersted. A wire conveying a current in the

direction shown by the straight arrow, Fig. 264, or from + to —, will deflect a magnetic needle in the direction shown by the curved arrows.

The following rules show the direction of the

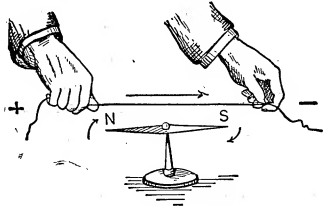

Fig. 264. Oersted's Experiment.

deflection of a magnetic pole by an electrical current :

(1.) Place the right hand on the conductor through which the current is flowing, with the palm facing the north pole, and with the fingers pointing in the direction of the current. The thumb will indicate the direction in which the north pole tends to move.

(2.) Suppose an ordinary corkscrew so placed along the conductor, through which a current of electricity is passing, that when twisted, it will move in the direction of the current. The handle will then turn in the direction in which the north pole of the magnet tends to move.

(3.) Imagine one swimming along the conductor in the direction of the current and facing the magnet. The north pole will tend to move towards the left hand of the swimmer.

Prof. Forbes has shown that the direction of the deflection of a magnet by a current is such

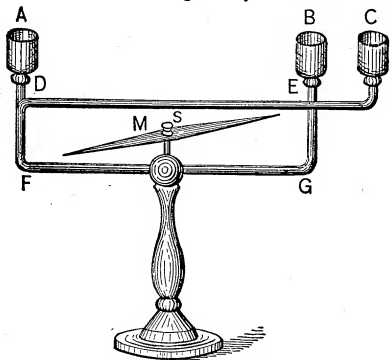

Fig. 265. Ampère's Apparatus.

that if the magnet were flexible, it would wrap itself round the current.

If the wire be bent in the form of a hollow rectangle F, D, E, G, Fig. 265, and the needle, M,

be placed inside the circuit, the upper and lower branches of the current will deflect the needle in the same direction, and the effect of the current will thus be multiplied. Mercury cups are provided at A, B and C, for a ready change in the direction of the current. (See *Needle, Astatic.*)

This principle of the multiplication of the deflecting power of a current was first applied to galvanometers by Schweigger, who used a number of turns of insulated wire for the purpose of obtaining a greater deflection of the needle. He called such a device a multiplier. In extremely sensitive galvanometers, very many turns of wire are employed, in some cases amounting to many thousands. Such galvanometers are of high resistance. Others, of low resistance, often consist of a single turn of wire and are used in the direct measurement of large currents.

A Schweigger's multiplier or coil C, C, of many turns of insulated wire, is shown in Fig. 266. The action of such a coil on the needle M, is comparatively great, even when the current is small.

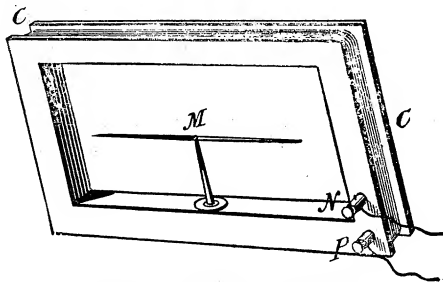

Fig. 266. Schweigger's Multiplier.

In the case of any galvanometer, when no current is passing, the needle, when at rest, should in general occupy a position parallel to the plane of the coil. On the passage of the current, the needle tends to place itself in a position at right angles to the direction of the current, or to the length of the conducting wire in the coil. The strength of the current passing is determined by observing the amount of this deflection as measured in degrees on a graduated circle over which the needle moves.

The needle is deflected by the current from a position of rest, either in the earth's magnetic field or in a field obtained from a permanent or an electro magnet. In the first case, when in use to measure a current, the plane of the galvanometer coils must coincide with the planes of the magnetic meridian. In the other case, the instru-

ment may be used in any position in which the needle is free to move.

Galvanometers assume a variety of forms according either to the purposes for which they are employed, or to the manner in which their deflections are valued.

Galvanometer, Absolute — — A galvanometer whose constant can be calculated with an absolute calibration. (See *Calibration, Absolute*.)

Such a galvanometer is called absolute because if the dimensions of its coil and needle are known, the current can be determined directly from the observed deflection of the needle.

Galvanometer, Aperiodic — — A galvanometer the needle of which comes to its position without any oscillation.

A dead-beat galvanometer. (See *Galvanometer, Dead-Beat*.)

Galvanometer, Astatic — — A galvanometer, the needle of which is astatic. (See *Needle, Astatic*.)

Nobili's astatic galvanometer is shown in Fig. 267. The astatic needle, suspended by a fibre *b*, has its lower needle placed inside a coil, *a*, consisting of many turns of insulated wire, its upper needle moving over the graduated dial. The current to be measured is led into and from the coil at the binding posts, *x* and *y*.

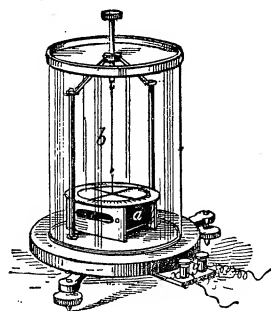

Fig. 267. Astatic Galvanometer.

In this instrument, if small deflections only are employed, the deflections are sensibly proportional to the strength of the deflecting currents.

Galvanometer, Ballistic — — A galvanometer designed to measure the strength of currents that last but for a moment, such, for example, as the current caused by the discharge of a condenser.

The quantity of electricity passing in any circuit is equal to the current multiplied by the time. Since the current caused by the discharge of a condenser lasts but for a small time, during which it passes from zero to a maximum and back again to zero, the magnetic needle in a ballistic galvanometer takes the form of a ballistic pendulum, *i. e.*, it is given such a mass, and acquires such a slow motion, that its change of position does not

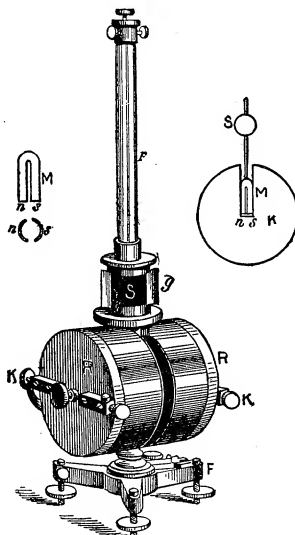

Fig. 268. Ballistic Galvanometer.

practically begin until the impulses have ceased to act.

In the ballistic galvanometer of Siemens and Halske, the coils *R, R*, Fig. 268, have a bell-shaped magnet, *M*, suspended inside them by means of an aluminium wire. The magnet is provided with a mirror *S*, for measuring the deflections. The bell-shaped magnet is shown in elevation at *M*, and in plane at *n, s*.

In using the ballistic galvanometer, it is necessary to see that the needle is absolutely at rest before the charge is sent through the coils.

A form of ballistic galvanometer by Nalder is shown in Fig. 269.

The ordinary form of compensating magnet is, in this galvanometer, replaced by the small magnet *A*, capable of rotation in a horizontal plane, but incapable of being raised or lowered, as is usual in such magnets. This form of compensating magnet possesses the advantage of being able to alter the direction of the field on the needle system,

without considerably altering its intensity. When the galvanometer is for ready use the magnet A, is turned until the needle is brought to zero. The

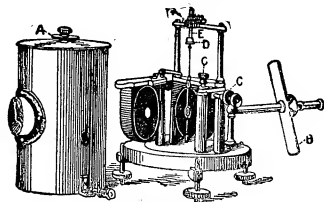

Fig. 269. Nalder's Galvanometer.

combined field of earth and magnet A, are then brought to the degree of sensitiveness required

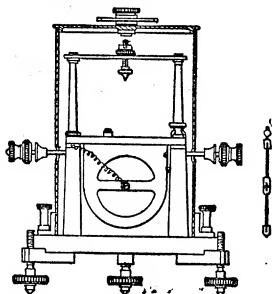

Fig. 270. Nalder's Galvanometer.

by rotating magnet B, on its shaft, or altering its distance from the needle. In order to insure ease in replacing the fibre, the front coil is hinged as shown. The fibre D, is supported on E, one end of which it is free to turn, so as to permit of the removal of torsion; D, being twisted can be raised or lowered at E. The needle system with heavy bell-shaped magnet is shown in Fig. 270.

Galvanometer, Combined Tangent and Sine — — A galvanometer furnished with two magnetic needles of different lengths. The small needle is used for tangent measurements, and the long needle for sine measurements.

Galvanometer Constant.—(See *Constant, Galvanometer.*)

Galvanometer, Dead-Beat — — A galvanometer, the needle of which comes quickly to rest, instead of swinging repeatedly to-and-fro. (See *Damping.*)

Galvanometer, Deprez-D'Arsonval — — A form of dead-beat galvanometer.

The movable part of the Deprez-D'Arsonval galvanometer consists of a light rectangular coil

C, Fig. 271, of many turns of wire, supported by two silver wires H J and D E, between the poles of a strong permanent horseshoe magnet A A. The position of the coil may be altered as to height by screws at H and E. The supporting wires, prevent by their torsion the swinging of the coil, as does also the cylinder of soft iron B, placed inside the coil, and supported independently of it. The movements of the coil are observed by means of a spot of light reflected from a mirror J, attached to the wire H J.

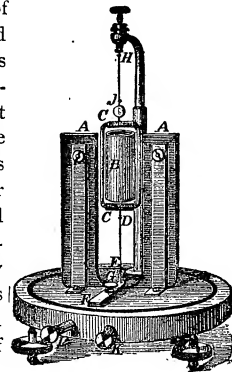

Fig. 271. Deprez-D'Arsonval Galvanometer.

Galvanometer, Detector — — A form of galvanometer employed for rough testing work.

A form of detector galvanometer is shown in Fig. 272.

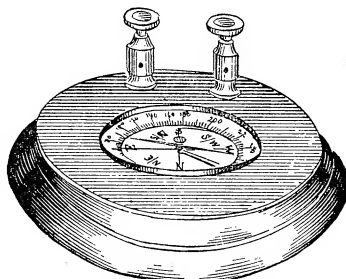

Fig. 272. Detector Galvanometer.

Galvanometer, Differential — — A galvanometer containing two coils so wound as to tend to deflect the needle in opposite directions.

The needle of a differential galvanometer shows no deflection when two equal currents are sent through the coils in opposite directions, since, under these conditions, each coil neutralizes the other's effects. Such instruments may be used in comparing resistances. The Wheatstone Bridge, however, in most cases, affords a preferable method for such purposes. (See *Bridge, Electric.*)

A form of differential galvanometer is shown in Fig. 273.

Sometimes the current is so sent through the two coils, that each coil deflects the needle in the same direction. In this case the instrument is no longer differential in action.

If the magnetic needle, in such cases, is suspended at the exact centre of the line which joins the centres of the coils, the advantage is gained by obtaining a field of more nearly uniform intensity

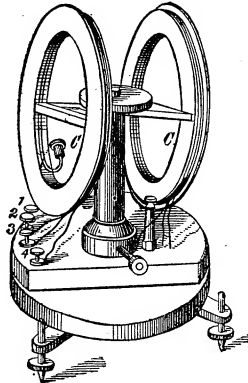

Fig. 273. Differential Galvanometer.

Galvanometer, Figure of Merit of — —

The reciprocal of the current required to produce a deflection of the galvanometer needle through one degree of the scale.

The smaller the current required to produce a deflection of one degree, the greater the figure of merit, or the greater the sensitiveness of the galvanometer.

Galvanometer, Marine — —A galvanometer devised by Sir William Thomson for use on steamships where the motion of magnetized masses of iron would seriously disturb the needles of ordinary instruments.

An unshielded needle would be so much affected by the motion of the engines, the shaft and the screw, as to be useless for galvanometric measurement.

The needle of the marine galvanometer is shielded or cut off from the extraneous fields so produced, by the use of a magnetic screen or shield, consisting of an iron box with thick sides, inside of which the instrument is placed.

The needle is suspended by means of a silk fibre attached both above and below, in line with the centre of gravity of the needle. In this manner, the oscillations of the ship do not affect the needle.

Galvanometer, Mirror — —A galvanometer in which, instead of reading the deflections of the needle directly by its move-

ments over a graduated circle, they are read by the movements of a spot of light reflected from a mirror attached to the needle.

This spot of light moves over a graduated scale, or its movements are observed by means of a telescope.

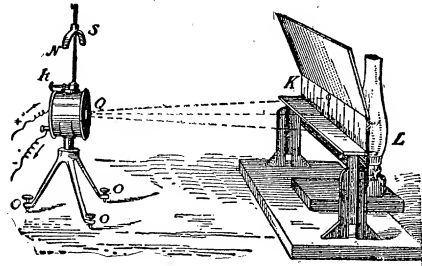

Fig. 274. Mirror Galvanometer.

A form of mirror galvanometer designed by Sir William Thomson is shown in Fig. 274. The needle is attached directly to the back of a light, silvered glass mirror, and consists of several small magnets made of pieces of a watch spring. The needle and mirror are suspended by a single silk fibre and are placed inside the coil. A compensating magnet N S, movable on a vertical axis, is used to vary the sensitiveness of the instrument. The lamp L, placed back of a slot in a wide screen K, throws a pencil of light on the mirror Q, from which it is reflected to the scale K.

A form of lamp and scale with slot for light is shown in Fig. 275.

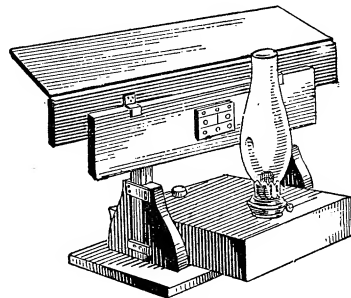

Fig. 275. Galvanometer Lamp and Scale.

Galvanometer, Potential — —A term sometimes applied to a voltmeter. (See *Voltmeter*.)

Galvanometer, Reflecting — —A term sometimes applied to a mirror galvanometer. (See *Galvanometer, Mirror*.)

Galvanometer, Sensibility of — —The readiness and extent to which the needle of a galvanometer responds to the passage of an electric current through its coils. (See *Galvanometer*.)

Galvanometer-Shunt.—(See *Shunt*, *Galvanometer*.)

Galvanometer, Sine — —A galvanometer in which a vertical coil is movable around a vertical axis, so that it can be made to follow the magnetic needle in its deflections.

In the sine galvanometer, the coil is moved so as to follow the needle until it is parallel with the coil. Under these circumstances, the strength of the deflecting currents in any two different cases is proportional to the sines of the angles of deflection.

A form of sine galvanometer is shown in Fig. 276. The vertical wire coil is seen at M. A needle of any length less than the diameter of the coil M, moves over the graduated circle N. The coil M, is movable over the graduated horizontal circle H, by which the amount of the movement

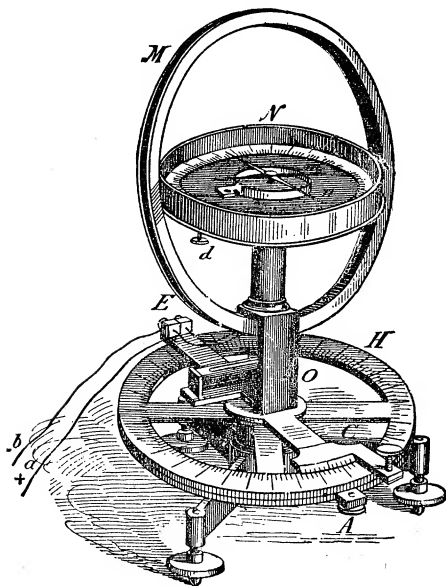

Fig. 276. Sine Galvanometer.

necessary to bring the needle to zero is measured. The current strength is proportional to the sine of the angle measured on this circle, through which it is necessary to move the coil M, from its

position when the needle is at rest in the plane of the earth's magnetic meridian, until the needle is not further deflected by the current, although parallel to the coil M.

Galvanometer, Tangent — —An instrument in which the deflecting coil consists of a coil of wire within which is placed a needle very short in proportion to the diameter of the coil, and supported at the centre of the coil.

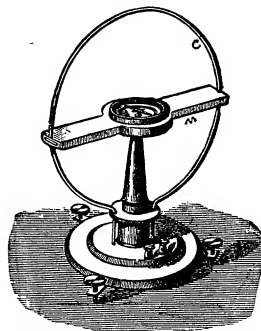

Fig. 277. Tangent Galvanometer.

A galvanometer acts as a tangent galvanometer only when the needle is very small as compared with the diameter of the coil. The length of the needle should be less than one-twelfth the diameter of the coil.

A form of tangent galvanometer is shown in Fig. 277. The needle is supported at the exact centre of the coil C.

Under these circumstances, the strengths of two different deflecting currents are proportional to the tangents of the angles of deflection. Tangent galvanometers are sometimes made with coils of wire containing many separate turns.

Galvanometer, Tangent, Obach's — — — A form of galvanometer in which the deflecting coil, instead of being in a fixed vertical position, is movable about a horizontal axis, so as to decrease the delicacy of the instrument, and thus increase its range of work.

Galvanometer, Torsion — —A galvanometer in which the strength of the deflecting current is measured by the torsion exerted on the suspension system.

A ball-shaped magnet, shown at the right of Fig. 278, is suspended by a thread and spiral

spring between two coils of high resistance, placed parallel to each other in the positions shown. On the deflection of the magnet, by the current to be measured, the strength of the current is determined by the amount of the torsion required to bring the magnet back to its zero point.

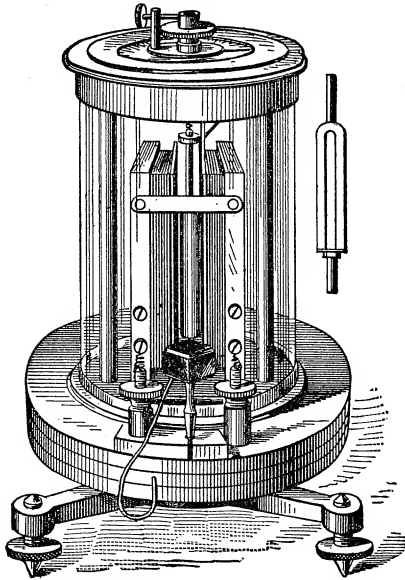

Fig. 278. Torsion Galvanometer.

The angle of torsion is measured on the horizontal scale at the top of the instrument.

In the torsion galvanometer, unlike the electro-dynamometer, the action between the coils and the movable magnet is as the current strength causing the deflection. In the electro-dynamometer, since an increase of current in the deflecting coils also takes place in the deflected coil, the mutual action of the two is as the square of the current strength causing the deflection.

Galvanometer, Upright — —A galvanometer, the needle of which moves in a vertical plane. (See *Galvanometer, Vertical*.)

Galvanometer, Vertical — —A galvanometer the needle of which is capable of motion in a vertical plane only.

In the vertical galvanometer, the north pole of the needle is weighted so that the needle assumes a vertical position when no current is passing. In the form shown in Fig. 279, two needles

are sometimes employed, one of which is placed inside the coils C, C.

The vertical galvanometer is not as sensitive as the ordinary forms. It is employed, however, in various forms for an electric current indicator, or even for a rough current measurer.

Galvanometer Voltmeter.—An instrument devised by Sir William Thomson, for the measurement of differences of electric potential.

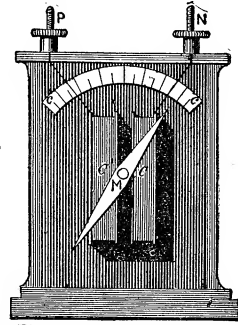

Fig. 279. Vertical Galvanometer.

This instrument is so arranged that by a single correction for the varying strength of the earth's field in any place, the results are read at once in volts.

A coil of insulated wire shown at A, Fig. 280, has a resistance of over 5,000 ohms. A magnetic needle, formed of short parallel needles placed above one another, and called a magnetometer needle, is attached to a long but light aluminium index, moving over a graduated scale. A movable, semi-circular magnet B, called the restoring magnet, is placed over the needle, and is used for varying the effect of the earth's field at any point. The sensitiveness of the instrument may be varied either by the restoring magnet or by sliding the magnetometer box nearer to or further away from the coil.

The voltmeter galvanometer depends for its operation on the fact that when a galvanometer of sufficiently high resistance is introduced be-

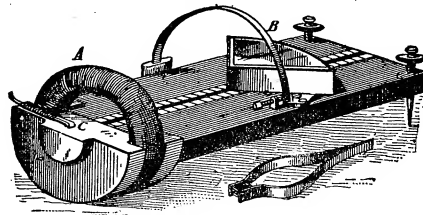

Fig. 280. Galvanometer Voltmeter.

tween any two points in a circuit, the current that passes through it, and hence the deflection of its needle, is directly proportional to the difference of potential between such two points.

Galvanometers for the commercial measurements of currents assume a variety of forms. They are generally so constructed as to read off the ampères, volts, ohms, watts, etc., directly. They are called ampèremeters or ammeters, voltmeters, ohmmeters, wattmeters, etc. For their fuller description reference should be had to standard works on electrical measurement.

Galvanometric.—Of or pertaining to the galvanometer. (See *Galvanometer*.)

Galvanometrical.—Of or pertaining to the galvanometer. (See *Galvanometer*.)

Galvanometrically.—In a galvanometric manner.

Galvano-Plastics.—(See *Plastics, Galvano*.)

Galvanoplasty.—The art of galvanoplastics. (See *Plastics, Galvano*.)

Galvano-Puncture.—(See *Puncture, Galvano*.)

Galvanoscope.—A term sometimes improperly employed in place of galvanometer.

A galvanoscope, strictly speaking, is an instrument intended rather to show the existence of an electric current than to measure it in degrees. It may, however, be roughly calibrated, and then it differs from a galvanometer only in delicacy and accuracy.

Galvano-Therapeutics.—A term sometimes used for electro-therapeutics.

Electro-therapeutics is by far the preferable term and is almost universally employed in the United States.

Gap, Air — —A gap, or opening in a magnetic circuit containing air only. (See *Gap, Air, Magnetic*.)

The air gap between two magnetic poles may be regarded as the space in which an armature acting as a magneto-receptive device is placed, which by the action upon it of the lines of magnetic force passing through the gap has differences of potential generated in its coils of insulated wire.

Gap, Air, Magnetic — —A gap filled with air which exists in the opening at any part of a core of iron or other medium of high permeability.

The space between the pole pieces and arma-

ture core is called the air gap in dynamos or motors even though partly filled with copper conductors. It is also called the interference space.

The gap or air space of an electro-magnet decreases the strength of its magnetization because—

The increased reluctance of the air gap causes a decrease in the number of lines of magnetic force which pass through the magnetic circuit.

Gap, Spark — —A gap forming part of a circuit between two opposing conductors, separated by air, or other similar dielectric which is closed by the formation of a spark only when a certain difference of potential is attained.

Gap, Wire-Gauge — —(See *Gauge, Wire, Gap*.)

Gas-Battery.—(See *Battery, Gas*.)

Gas Burner, Argand, Plain-Pendant, Electric — —(See *Burner, Argand Electric, Plain-Pendant*.)

Gas Burner, Argand, Ratchet-Pendant, Electric — —(See *Burner, Argand Electric, Ratchet-Pendant*.)

Gas Burner, Automatic Electric — —(See *Burner, Automatic Electric*.)

Gas Burner, Plain-Pendant, Electric — —(See *Burner, Plain-Pendant Electric*.)

Gas Burner, Ratchet-Pendant, Electric — —(See *Burner, Ratchet-Pendant Electric*.)

Gas, Carbonic Acid — —A gaseous substance formed by the union of one atom of carbon with two atoms of oxygen.

Carbonic acid gas is formed during the combustion of carbon by a sufficient supply of air.

Gas, Dielectric Density of — —A term sometimes employed instead of dielectric strength of gas. (See *Gas, Dielectric Strength of*.)

Gas, Dielectric Strength of — —The strain a gas is capable of bearing without suffering disruption, or without permitting a disruptive discharge to pass through it.

The dielectric strength of a gas depends—

(1.) On the nature of the gas.

(2.) On its pressure.

It has been calculated roughly that it requires 40,000 volts per centimetre to pass a disruptive discharge through dry air at ordinary pressures.

Gas-Jet, Carcel Standard — —(See *Carcel Standard Gas-Jet*.)

Gas-Jet Photometer.—(See *Photometer*.)

Gas-Lighting, Electric — —The electric ignition of a gas-jet from a distance.

Gas-Lighting, Multiple Electric — —
A system of electric gas-lighting in which a number of gas-jets are lighted by means of a discharge of high electromotive force, derived from a Ruhmkorff coil or a static induction machine.

Such devices are operated by means of minute electric sparks which are caused to pass through the escaping gas-jets.

The spark for this purpose is obtained either by means of the extra current from a spark coil, by means of an induction coil or by static discharges. (See *Currents, Extra. Coil, Spark. Coil, Induction*.)

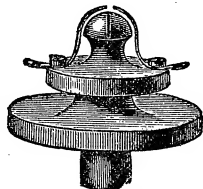

Fig. 281. Multiple Gas-Jet.

A gas tip for use in multiple gas-lighting apparatus is shown in Fig. 281. The spark is formed immediately over the slot in the burner, and therefore ignites the escaping gas.

Gas, Occlusion of — —The absorption or shutting up of a gas in the pores, or on the surfaces of various substances.

Carbon possesses in a marked degree the property of occluding or absorbing gases in its pores. These occluded gases must be driven out from the carbon conductor employed in an incandescent lamp, since otherwise their expulsion, on the incandescence of the carbon, consequent on the lighting of the lamp, will destroy the high vacuum of the lamp chamber and thus lead to the ultimate destruction of the filament. (See *Lamp, Electric, Incandescent*.)

Gassing.—The evolution of gas from the plates of a storage or secondary cell.

Gastroscope.—An electric apparatus for the illumination and inspection of the human stomach.

The light is obtained by means of a platinum spiral in a glass tube surrounded by a layer of water to prevent undue heating. The platinum spiral is placed at the extremities of a tube, provided with prisms, and passed into the stomach of the patient. A separate tube for the supply of air for the extension of the stomach is also provided.

Gastroscopy.—The examination of the stomach by the gastroscope. (See *Gastroscope*.)

Gauge, Battery.—A form of portable galvanometer, suitable for ordinary testing work.

A form of battery gauge is shown in Fig. 282.

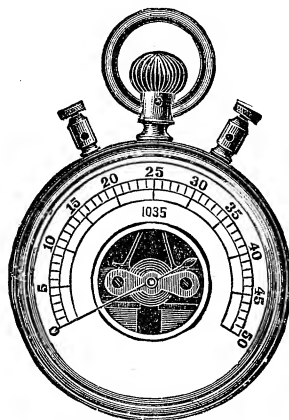

Fig. 282. Battery Gauge.

Gauge, Electrometer — —A device employed in connection with some of Sir William Thomson's electrometers to ascertain whether the needle, connected with the layer of acid that acts as the inner coating of the Leyden jar used in connection therewith, is at its normal potential.

Gauge, Wire, American — —A name sometimes applied to the Brown & Sharpe Wire Gauge. (See *Gauges, Wire, Varieties of*.)

Gauge, Wire, Birmingham — —A term sometimes applied to one of the English wire gauges.

Gauge, Wire, Gap — —A wire gauge in which gaps are left for the introduction of the wire to be measured.

Gauge, Wire, Micrometer — A gauge employed for accurately measuring the diameter of a wire in thousandths of an inch, based on the principle of the vernier or micrometer. (See Fig. 283.)

The wire to be measured is placed between a fixed support B, and the end C, of a long movable screw, which accurately fits a threaded tube a. A thimble D, provided with a milled head, fits over the screw C, and is attached to the upper part. The lower circumference of D, is divided into a scale of twenty equal parts. The tube A, is graduated into divisions equal to the pitch of the screw. Every fifth of these divisions is marked as a larger division.

The principle of the operation of the gauge is as follows: Suppose the screw has fifty threads to the inch, the pitch of the screw, or the distance between two contiguous threads, is therefore $\frac{1}{50}$ or .02 of an inch.

One complete turn of the screw will, therefore, advance the sleeve D, over the scale a, the .02 of an inch. If the screw is only moved through one of the twenty parts marked on the end of the thimble or sleeve parts, or the $\frac{1}{250}$ of a com-

plete turn, the end C, advances towards B, the $\frac{1}{250}$ of $\frac{1}{50}$, i. e., $\frac{1}{10000}$ or .001 inch.

Suppose now a wire is placed between B and C, and the screw advanced until it fairly fills the

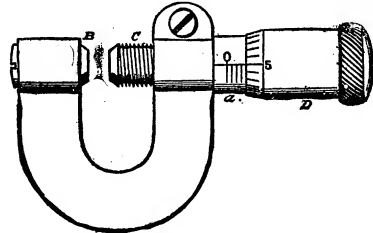

Fig. 283. Vernier Wire Gauge.

space between them, and the reading shows two of the larger divisions on the scale a, three of the smaller ones and three on the end of the sleeve D, then

Two large divisions of scale a..... = .2 inch
 Three smaller divisions of scale a.. = .06 "
 Three divisions on circular scale
 on D..... = .003 "
 Diameter of wire..... = .263

Serious inconvenience has arisen in practice

NEW LEGAL STANDARD WIRE GAUGE (ENGLISH).
 Tables of Sizes, Weights, Lengths and Breaking Strains of Iron Wire.

Size on Wire Gauge.	Diameter.		Sectional area in sq. inches.	Weight of		Length of Cwt.	Breaking Strains.		Size on Wire Gauge.
	Inch.	Millimetres.		100 yards.	Mile.		Annealed.	Bright.	
7/0.....	.500	12.7	.1963	Lbs. 193.4	Lbs. 3404	Yards. 58	Lbs. 10470	Lbs. 15700	7/0
6/0.....	.471	11.8	.1691	166.5	2930	67	9017	13525	6/0
5/0.....	.432	11.	.1466	144.4	2541	78	7814	11725	5/0
4/0.....	.400	10.2	.1257	123.8	2179	91	6702	10052	4/0
3/0.....	.372	9.4	.1087	107.1	1885	105	5796	8694	3/0
2/0.....	.348	8.8	.0951	93.7	1619	120	5072	7608	2/0
1/0.....	.324	8.2	.0824	81.2	1429	138	4397	6595	1/0
1.....	.300	7.6	.0707	69.9	1225	161	3770	5655	1
2.....	.276	7.	.0598	58.9	1037	190	3190	4785	2
3.....	.252	6.4	.0499	49.1	864	228	2660	3990	3
4.....	.232	5.9	.0423	41.6	732	269	2254	3381	4
5.....	.212	5.4	.0353	34.8	612	322	1883	2824	5
6.....	.192	4.9	.0290	28.0	502	393	1544	2316	6
7.....	.176	4.5	.0243	24.	422	467	1298	1946	7
8.....	.160	4.1	.0201	19.8	348	566	1072	1608	8
9.....	.144	3.7	.0163	16.	282	700	869	1303	9
10.....	.128	3.3	.0129	12.7	223	882	687	1030	10
11.....	.116	3.	.0106	10.4	183	1077	564	845	11
12.....	.104	2.6	.0085	8.4	148	1333	454	680	12
13.....	.092	2.3	.0066	6.5	114	1723	355	532	13
14.....	.080	2.	.0050	5.	88	2240	268	402	14
15.....	.072	1.8	.0041	4.	70	2800	218	326	15
16.....	.064	1.6	.0032	3.2	56	3500	172	257	16
17.....	.056	1.4	.0025	2.4	42	4607	131	197	17
18.....	.048	1.2	.0018	1.8	32	6222	97	145	18
19.....	.040	1.	.0013	1.2	21	9333	67	100	19
20.....	.036	.9	.0010	1.	18	11200	55	82	20

(Issued by the Iron and Steel Wire Manufacturers' Association.)

from the numerous arbitrary numbers of sizes of wires employed by different manufacturers. These differences are gradually leading to the abandonment of arbitrary sizes for wires and employing in place thereof the diameters directly in inches or thousandths of an inch.

Gauge, Wire, Round — — A device for accurately measuring the diameter of a wire.

The round wire gauge shown in Fig. 284 is very generally used for telegraph lines. Notches

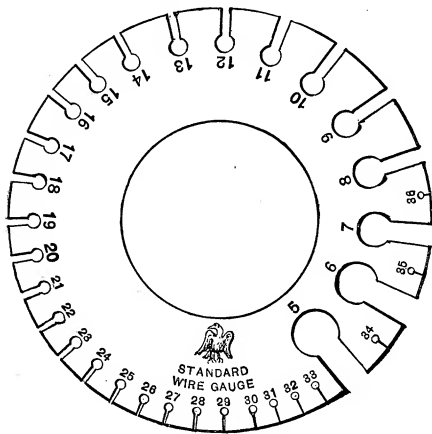

Fig. 284. Round Wire Gauge.

for varying widths, cut in the edges of a circular plate of tempered steel, serve to approximately measure the diameter of a wire, the sides of the wire being passed through the slots. Numbers, indicating the different sizes of the wire, are affixed to each of the openings.

Gauge, Wire, Self-Registering — — A wire gauge arranged to give the exact diameter of the wire to be measured directly without calculation.

A form of self-registering wire gauge is shown in Fig. 285. The wire or plate is inserted in the gap between a fixed and a movable plate. The numbers corresponding to the diameter of the wire or plate are shown on one side of the gauge and the gauge numbers on the other side.

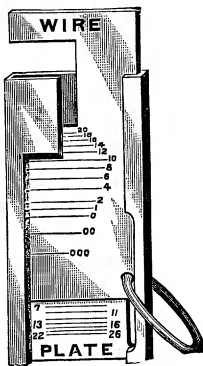

Fig. 285. Wire and Plate Gauge.

Gauge, Wire, Standard — — A wire gauge adopted by the National Telephone Exchange Association at Providence, R. I., and by the National Electric Light Association, at Baltimore, Md., in February, 1886.

The value of the standard as compared with the other gauges will be seen from an inspection of the table in this column:

Gauges, Wire, Varieties of — — The following table gives a comparison of the principal wire gauges in use.

COMPARISON OF THE DIFFERENT WIRE GAUGES.

Number of Wire Gauge.	American or Brown & Sharpe.	Birmingham, or Stubs.	Washburn & Moen Mfg. Co., Worcester, Mass.	Trenton Iron Co., Trenton, N. J.	Standard Wire Gauge.	Old English from Brass Mfrs.' List.
00000046			
0000043	.45		
0000	.46	.454	.393	.4	.400	
000	.40964	.425	.362	.36	.372	
00	.3648	.38	.331	.33	.348	
0	.32495	.34	.307	.305	.324	
1	.2893	.3	.283	.285	.300	
2	.25763	.284	.263	.265	.276	
3	.22942	.259	.244	.245	.252	
4	.20431	.238	.225	.225	.232	
5	.18104	.22	.207	.205	.212	
6	.16202	.203	.192	.19	.192	
7	.14428	.18	.177	.175	.176	
8	.12849	.165	.162	.16	.160	
9	.11443	.148	.148	.145	.144	
10	.10189	.134	.135	.13	.128	
11	.090742	.12	.12	.1175	.116	
12	.080808	.109	.105	.105	.104	
13	.07161	.095	.092	.0925	.092	
14	.064084	.083	.08	.08	.080	.083
15	.057068	.072	.072	.072	.072	.072
16	.05082	.065	.063	.061	.064	.065
17	.04525	.058	.052	.0525	.056	.058
18	.040303	.049	.047	.045	.048	.049
19	.035990	.042	.041	.039	.040	.04
20	.031661	.035	.035	.034	.036	.035
21	.028462	.032	.032	.03	.032	.0315
22	.025347	.028	.028	.27	.028	.0295
23	.022571	.025	.025	.024	.024	.027
24	.0201	.022	.023	.0215	.022	.025
25	.0179	.02	.02	.019	.020	.023
26	.01594	.018	.018	.018	.018	.0205
27	.014195	.016	.017	.017	.0164	.01875
28	.012641	.014	.016	.016	.0148	.0165
29	.011257	.013	.015	.015	.0136	.0155
30	.010025	.012	.014	.014	.0124	.01375
31	.008928	.01	.0135	.013	.0116	.01225
32	.00795	.009	.013	.012	.0108	.01125
33	.00708	.008	.011	.011	.0100	.01025
34	.006304	.007	.01	.01	.0092	.0095
35	.005614	.005	.0095	.009	.0084	.009
36	.005	.004	.009	.008	.0076	.0075
37	.0044530085	.00725	.0068	.0065
38	.003965008	.0065	.006	.00575
39	.0035310075	.00575	.0057	.005
40	.003144007	.005	.0048	.0045

NUMBER, DIAMETER, WEIGHT, LENGTH AND RESISTANCE OF PURE COPPER WIRE.

American Gauge.

No.	Diameter. Inches.	Weight, sp. gr. = 8.89.		Length.	Resistance of Pure Copper at 70° Fahrenheit.		
		Grs. per ft.	Lbs. per 1,000 feet.	Ft. per lb.	Ohms per 1,000 ft.	Feet per ohm.	Ohms per lb.
0000...	.46000	4475.33	640.40	1.56	.051	19605.69	.0000798
000...	.40964	3549.07	507.01	1.97	.064	15547.87	.000127
00...	.36480	2814.62	402.09	2.49	.081	12330.36	.000202
0...	.32486	2233.28	319.04	3.13	.102	9753.63	.000320
1...	.28930	1770.13	252.88	3.95	.129	7754.66	.00051
2...	.25763	1403.79	200.54	4.99	.163	6149.78	.000811
3...	.22942	1113.20	159.03	6.29	.205	4876.73	.001289
4...	.20431	882.85	126.12	7.93	.259	3867.62	.00205
5...	.18194	700.10	100.01	10.00	.326	3067.06	.00326
6...	.16202	555.0	79.32	12.61	.411	2432.22	.00518
7...	.14429	440.27	62.90	15.90	.519	1928.75	.00824
8...	.12849	349.18	49.88	20.05	.654	1529.69	.01311
9...	.11443	276.94	39.56	25.28	.824	1213.22	.02083
10...	.10190	219.57	31.37	31.88	1.040	961.91	.03314
11...	.09074	174.15	24.88	40.20	1.311	762.93	.05269
12...	.08081	138.11	19.73	50.69	1.653	605.03	.08377
13...	.07196	109.52	15.05	63.91	2.084	479.80	.13321
14...	.06408	86.86	12.41	80.59	2.628	380.51	.2118
15...	.05707	68.88	9.84	101.63	3.314	301.75	.3368
16...	.05082	54.63	7.81	128.14	4.179	239.32	.5355
17...	.04525	43.32	6.19	161.59	5.269	189.78	.8515
18...	.04030	34.35	4.91	203.76	6.645	150.50	1.3539
19...	.03589	26.49	3.78	264.26	8.617	116.05	2.2772
20...	.03196	21.61	3.09	324.00	10.566	94.65	3.423
21...	.02846	17.13	2.45	408.56	13.323	75.06	5.443
22...	.025347	13.59	1.94	515.15	16.799	59.53	8.654
23...	.022572	10.77	1.54	649.66	21.185	47.20	13.763
24...	.0201	8.54	1.22	819.21	26.713	37.43	21.885
25...	.0179	6.78	.97	1032.96	33.684	29.69	34.795
26...	.01594	5.37	.77	1302.61	42.477	23.54	55.331
27...	.014195	4.26	.61	1642.55	53.593	18.68	87.979
28...	.012641	3.38	.48	2071.22	67.542	14.81	139.893
29...	.011258	2.68	.38	2611.82	85.170	11.74	222.449
30...	.010025	2.13	.30	3293.97	107.391	9.31	353.742
31...	.008928	1.69	.24	4152.22	135.402	7.39	562.221
32...	.00795	1.34	.19	5236.66	170.765	5.86	894.242
33...	.00708	1.06	.15	660.271	215.312	4.64	1421.646
34...	.0063	.84	.12	8328.30	271.583	3.68	2261.82
35...	.00561	.67	.10	10501.35	342.413	2.92	3596.104
36...	.005	.53	.08	13238.83	431.712	2.32	5715.36
37...	.00445	.42	.06	16691.06	544.287	1.84	9084.71
38...	.003965	.34	.05	20854.65	686.511	1.46	14320.26
39...	.003531	.27	.04	26302.23	865.046	1.16	22752.6
40...	.003144	.21	.03	33175.94	1091.865	.92	36223.59

Gauss.—The unit of intensity of magnetic field.

The term gauss for unit of intensity of magnetic field was proposed by S. P. Thompson as being that of a field whose intensity is equal to 10⁸ C. G. S. units, that is, 10⁸ lines of force per square centimetre.

J. A. Fleming proposes, for the value of the gauss, such strength of field as would develop an electromotive force of one volt in a wire one million centimetres in length, moving through such a field with unit velocity.

Fleming's value for the gauss was assumed on account of the small value of the gauss proposed

by S. P. Thompson. It is one hundred times greater in value than Thompson's gauss.

Sir William Thomson proposes, for the value of the gauss, such an intensity of magnetic field as is produced by a current of one weber (ampère) at the distance of one centimetre.

Gauss, Fleming's — — Such a strength of magnetic field as is able to develop an electromotive force of one volt in a wire one million centimetres in length moved through the field with unit velocity. (See Gauss.)

Gauss, S. P. Thompson's — — Such a strength of magnetic field that its intensity is equal to 10⁸ C. G. S. units. (See Gauss.)

Gauss, Sir William Thomson's — — Such an intensity of magnetic field as would be produced by a current of one ampère at the distance of one centimetre. (See *Gauss*.)

Geissler Mercurial Pump.—(See *Pump, Air, Geissler, Mercurial*.)

Geissler Tubes.—(See *Tubes, Geissler*.)

General Faradization.—(See *Faradization, General*.)

General Galvanization.—(See *Galvanization, General*.)

Generation of Current by Dynamo-Electric Machine.—(See *Current, Generation of, by Dynamo-Electric Machine*.)

Generator, Dynamo-Electric — — An apparatus in which electricity is produced by the mechanical movement of conductors through a magnetic field so as to cut the lines of force.

A dynamo-electric machine. (See *Machine, Dynamo-Electric*.)

A dynamo electric machine operates on the general principles of electro-dynamic induction. Strictly speaking, however, in a dynamo-electric generator the conductors are actually moved through the lines of force. In this respect, therefore, a dynamo-electric generator differs from a transformer, in which the lines of force are moved through the conductor. (See *Induction, Electro-Dynamic. Transformer. Inaction, Mutual*.)

Generator, Motor — — A dynamo-electric generator in which the power required to drive the dynamo is obtained from an electric current.

Motor generators are used in systems of electrical distribution for the purpose of changing the potential of the current. They consist of dynamos, the armatures of which are furnished with two separate windings, of fine and coarse wire respectively. One of these, generally the fine wire, receives the driving or motor current, usually of high potential, and the other, the coarse wire, furnishes the current used, usually of low potential.

The advantage of having the windings, which receive the driving current, of fine wire, is to enable a current of high potential to be distributed over the line from distant stations to

places where it is desired to use the energy of the current at a much lower potential.

Motor generators often consist simply of two distinct machines mechanically connected, one acting as a motor and the other as a dynamo.

Motor generators are sometimes called dynamomotors or dynamotors.

Aldrich draws the following distinction between a dynamo-motor and a dynamotor :

(1.) A dynamo-motor is an energy transformer with the dynamo and motor in the same electric circuit.

(2.) A dynamotor is an energy transformer with the dynamo and motor in the same magnetic circuit.

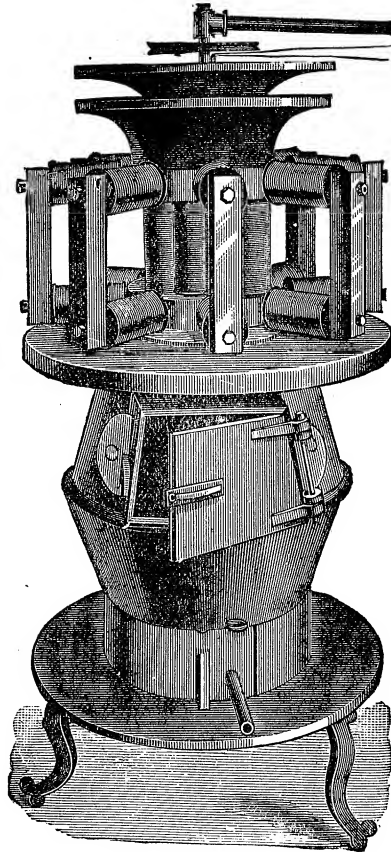

Fig. 286. Edison's Pyro-Magnetic Generator.

Generator, Pyro-Magnetic — — An apparatus for producing electricity directly from heat derived from the burning of fuel.

The operation of the pyro-magnetic generator is dependent upon the fact that any variation in the number of lines of magnetic force that pass through a conductor will develop differences of electric potential therein. Such variations may be effected either by varying the position of the conductor as regards the magnetic field, or by varying the magnetic field itself. The latter method of generating differences of potential is utilized in the pyro-magnetic generator, and is effected in it by varying the magnetization of rolls of thin iron or nickel by the action of heat.

A form of pyro-magnetic generator devised by Edison is shown in Figs. 286 and 287.

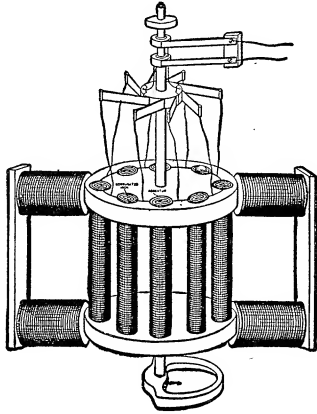

Fig. 287. Edison's Pyro-Magnetic Generator.

This apparatus is sometimes called a pyro-magnetic dynamo.

Eight electro-magnets are provided, each with an armature consisting of a roll of corrugated iron. Each of these armatures is provided with a coil of insulated wire wound on it and protected by asbestos paper. The armatures pass through two iron discs as shown. The armature coils are connected in series in a closed-circuit, the wires from the coils being connected with metallic brushes that rest on a commutator supported on a vertical axis. A pair of metallic rings is provided above the commutator to carry off the current generated.

The vertical axis is provided below with a semi-circular screen called a guard plate which rotates with the axis and cuts off or screens one half the iron armatures from the heated air.

When the axis is rotated, the difference in the

magnetization of the armatures, when hot and cold, develops electromotive forces which result in the production of an electric current.

Generator, Secondary — — A term frequently employed for a converter or transformer.

The word transformer is now almost universally employed. (See *Transformer*.)

Generator, Watt — — A term sometimes employed for stating the power in watts that any electric source is capable of producing.

Estimating the power of a dynamo-electric machine by the number of watts it is capable of producing is very convenient in practice, and is now very generally adopted. A dynamo capable of furnishing a difference of potential of 1,000 volts, and a current of 10 ampères, would be said to be a 10,000 watt-generator.

The term watt-generator, though applicable to the case of any electric source, is in practice generally limited to the case of dynamo-electric machines or secondary batteries.

Generators, Motor, Distribution of Electricity by — — (See *Electricity, Distribution of, by Motor Generators*.)

Geographical Distribution of Thunder Storms.—(See *Storms, Thunder, Geographical Distribution of*.)

Geographical Equator.—(See *Equator, Geographical*.)

Geographical Meridian.—(See *Meridian, Geographical*.)

German Silver Alloy.—(See *Alloy, German Silver*.)

Gilding, Electric — — The electrolytic deposition of gold on any object.

Electro-plating with gold. (See *Plating, Electro*.)

The surfaces of the object to be gilded are made electrically conducting, if not already so, and are then connected to the negative terminal of a voltaic cell or other source, and immersed in a plating bath containing a solution of a salt of gold, directly opposite a plate of gold, connected with the positive terminal of the source. The objects to be plated thus become the cathode, and the plate of gold the anode of the plating bath. On the passage of a suitable current, the gold is dissolved from the plate at the anode and deposited

on the object at the kathode. (See *Bath, Gold. Kathode. Anode.*)

Gilt Plumbago.—(See *Plumbago, Gilt.*)

Gimbals.—Concentric rings of brass, suspended on pivots in a compass box, and on which the compass card is supported so as to enable it to remain horizontal notwithstanding the movements of the ship. (See *Compass, Azimuth.*)

Each ring is suspended on two pivots placed directly opposite each other, that is, at the ends of a diameter, which in one ring is at right angles to that in the other.

Girder Armature.—(See *Armature, Girder.*)

Globe, Vapor, of Incandescence Lamp — —A glass globe surrounding the chamber of an incandescent electric lamp, for the purpose of enabling the lamp to be safely used in an explosive atmosphere, or to permit the lamp to be exposed in places where water is liable to fall on it.

Such a vapor globe is shown in Fig. 288. In the event of accidental breakage of the outside globe, the lamp chamber proper prevents the ignition of the explosive gases. In such cases, however, the outer protecting chamber should be promptly replaced.

In some forms of vapor globes, a valve is provided, opening outwards, in order to permit the expanded air to escape when a given pressure is reached, and yet, at the same time, to prevent the entrance of gas or vapor from without.

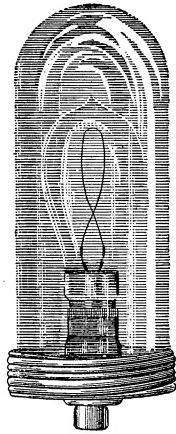

Fig. 288. Vapor Globe.

Glow Discharge.—(See *Discharge, Glow.*)

Glow Lamp.—(See *Lamp, Electric Glow.*)

Gold Bath.—(See *Bath, Gold.*)

Gold-Leaf Electroscope.—(See *Electroscope, Gold-Leaf.*)

Gold-Plating.—(See *Plating, Gold.*)

Gong, Electro-Mechanical — —A gong

struck or operated by mechanical force at times which are dependent on the passage of an electric current.

The motive power is the mechanical force developed by a bent spring, the fall of a weight, etc., and, by suitable mechanism, is permitted to act only on the passage of an electric current.

Governor, Centrifugal — —A device for maintaining constant the speed of a steam engine or other prime mover, despite sudden changes in the load or work.

In a ball governor, any increase in speed causes the balls to fly out from the centre of rotation by centrifugal force. This motion is utilized to control a valve or other regulating device. If the speed of the engine falls, the balls move towards the centre, shifting the valve or regulating device in the opposite direction.

Governor, Current — —A current regulator.

A device for maintaining constant the current strength in any circuit.

Current governors are either automatic or non-automatic. (See *Regulation, Automatic.*)

Governor, Electric — —A device for electrically controlling the speed of a steam engine, the direction of current in a plating bath, the speed of an electric motor, the resistance of an electric circuit, the flow of water or gas into or from a containing vessel, or for other similar purposes.

The particular form assumed by the apparatus varies with the character of the work it is intended to accomplish. In some cases an ordinary ball or centrifugal governor is employed to open or close a circuit; or, a mass of mercury in a rotating vessel is caused, at a certain speed, to open or close a circuit; or, the resistance of a bundle of carbon discs is caused to vary, either by pressure produced by centrifugal force, or by the movement of an armature.

Governor, Periodic — —A name applied by Ayrton & Perry to a form of governor for an electric motor, in which the current is automatically cut out for a certain portion of each revolution.

Governor, Spasmodic — —A name given by Ayrton & Perry to a form of governor for an electric motor, in which the cur-

rent is automatically cut off in proportion as the work is cut off.

The spasmodic governor consists essentially of a cone dipping into the surface of mercury in a rotating vessel. As the speed of the governor increases on a lightening of the load, the surface of the mercury is curved by the increased centrifugal force, until finally the mercury leaves the contact point and thus cuts off the current.

Governor, Steam, Electric — —A device used in connection with a valve to so electrically regulate the supply of steam to an engine, that the engine shall be driven at such a speed as will maintain either a constant current or a constant potential.

In the electric governor, the steam valve is operated by an electro-magnet, whose coils, in the case of a constant current machine, are of thick wire placed in the main circuit, and, in that of a constant potential machine, are of thin wire placed in a shunt around the mains.

Graduators.—Devices, generally electromagnetic, employed in systems of simultaneous telegraphic and telephonic transmission over the same wire, so inserted in the line circuit as to obtain the makes and breaks required in a system of telegraphic communication so gradually that they fail to sensibly influence the diaphragm of a telephone placed in the same circuit.

Gramme.—A unit of weight equal to 15.43235 grains.

The gramme is equal to the weight of one cubic centimetre of pure water at the temperature of its maximum density. It has various multiples and decimal divisions—of the former, the kilogramme or one thousand grammes is the most frequently used; of the latter, the centigramme or the one-hundredth of a gramme, and the milligramme or the one-thousandth of a gramme. (See *Weights and Measures, Metric System of.*)

Gramme Atom.—(See *Atom, Gramme.*)

Gramme Molecule.—(See *Molecule, Gramme.*)

Gramophone.—An apparatus for recording and reproducing articulate speech. (See *Phonograph.*)

Gramophone Record.—(See *Record, Gramophone.*)

Graphite.—A soft variety of carbon suitable for writing on paper or similar surfaces.

Graphite is the material that is employed for the so-called black lead of lead pencils. It is sometimes called plumbago. Strictly speaking, the term graphite is only applicable to the variety of plumbago suitable for use in lead pencils.

Graphite is used for rendering surfaces to be electro-plated, electrically conducting, and also for the brushes of dynamos and motors. For the latter purpose it possesses the additional advantage of decreasing the friction by means of its marked lubricating properties.

Graphophone, Micro — —A modification of the phonograph in which, instead of a single diaphragm, a number of separate non-metallic diaphragms are caused to act on a single diaphragm to record the speech, so that the separate diaphragms can be thrown into strong vibration when reproducing the speech.

Graphophone, Phonograph — —A term sometimes applied to the graphophone. (See *Graphophone, Micro. Phonograph.*)

Graphophone Record.—(See *Record, Graphophone.*)

Gray's Harmonic Telegraphic Analyzer.—(See *Analyzer, Gray's Harmonic Telegraphic.*)

Gray's Harmonic Telegraphy.—(See *Telegraphy, Gray's Harmonic Multiple.*)

Gravitation.—A name applied to the force which causes masses of matter to tend to move towards one another.

This motion is assumed to be that of attraction, that is, the bodies are assumed to be drawn together. It is not impossible, however, that they may be pushed together.

Gravitation, like electricity, is well known, so far as its effects are concerned; but, as to the true cause of either, particularly the former, we are in comparative ignorance.

The general facts of gravitation may be succinctly stated by the following law, generally known as Newton's law.

Every particle of matter in the universe is attracted by every other particle of matter, and itself attracts every other particle of matter, with a force which is directly proportional to the product of the masses of the two quantities of matter

and inversely proportional to the square of the distance between them.

Gravity Ammeter.—(See *Ammeter, Gravity*.)

Gravity, Centre of — —The centre of weight of a body.

Bodies supported at their centres of gravity are in equilibrium, since their weight is then evenly distributed around the point of support.

Gravity-Drop Annunciator.—(See *Annunciator, Gravity-Drop*.)

Gravity, Voltaic Cell — —(See *Cell, Voltaic, Gravity*.)

Gravity Voltmeter.—(See *Voltmeter, Gravity*.)

Great Calorie.—(See *Calorie, Great*.)

Grenet Voltaic Cell.—(See *Cell, Voltaic, Grenet*.)

Grid.—A lead plate, provided with perforations, or other irregularities of surface, and employed in storage cells for the support of the active material.

The support provided for the active material on the plate of a secondary or storage cell.

The grid receives its name from its resemblance to a gridiron. The active material is generally maintained on the grid by means of variously shaped apertures or holes. These are generally larger near the centre, so as to prevent the falling out of the material after it has been hardened by compression. (See *Cell, Secondary, Cell, Storage*.)

Various forms have been given to the grid. The object of these forms, in general, is to insure the retention of the active material by the grid.

The grids are preferably suspended from suitable supports fastened to the top of the battery jars, instead of resting on the bottom of the battery jars.

Grip, Cable — —A grip provided for seizing the end of a cable when it is to be drawn into a duct or conduit.

Grove's Voltaic Cell.—(See *Cell, Voltaic, Grove*.)

Grothüss' Hypothesis.—(See *Hypothesis, Grothüss'*.)

Ground Circuit.—(See *Circuit, Ground*.)

Ground Detector.—(See *Detector, Ground*.)

Ground or Earth.—A general term for the earth when employed as a conductor, or as a large reservoir of electricity.

The term ground is also applied to a fault caused by an accidental and undesired connection between an electric circuit, line or apparatus and the ground. (See *Fault*.)

Ground Plate of Lightning Protector.—(See *Plate, Ground, of Lightning Protector*.)

Ground-Return.—A general term used to indicate the use of the ground or earth for a part of an electric circuit.

The earth or ground which forms part of the return path of an electric circuit.

The ground-return is generally used in the Morse system of telegraphy as practiced in the United States.

Ground-Wire.—The wire or conductor leading to or connecting with the ground or earth in a grounded circuit.

This is sometimes called an earth-grounded wire.

A circuit is grounded when it is completed in part by the ground or earth.

Grounded Circuit.—(See *Circuit, Grounded*.)

Growth or Expansion of Lines of Force.—(See *Force, Lines of, Growth or Expansion of*.)

Guard, Fan — —A wire netting placed around the fan of an electric motor for the purpose of preventing its revolving arms from striking external objects.

Guard, Lightning — —A term sometimes used for lightning rod. (See *Rod, Lightning*.)

Guard, Transformer, Lightning — —A transformer lightning arrester. (See *Arrester, Lightning, Transformer*.)

Guard, Wire Shade — —A guard of wire netting provided for the protection of a shade.

A form of wire shade is shown in Fig. 289.

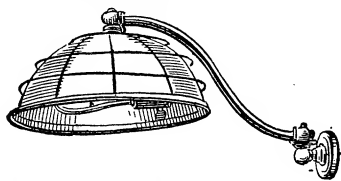

Fig. 289. Wire Shade Guard.

Gutta-Percha.—A resinous gum obtained from a tropical tree, and valuable electrically for its high insulating powers.

Gutta-percha readily softens by heat, but on

cooling becomes hard and tough. Unlike India-rubber, it possesses but little elasticity. Its specific inductive capacity is 4.2, that of air being 1, and of vulcanized rubber, 2.94. (See *Capacity, Specific Inductive.*)

Gutta-percha is obtained largely from the East Indies, from a tree which yields a brownish gum. It is a fibrous and tenacious substance with but little flexibility, and is unaffected by acids. Oils produce less effect upon it than on India-rubber.

Gutta-percha is one of the best insulating materials known for sub-aqueous cables.

Gymnotus Electricus.—The electric eel. (See *Eel, Electric.*)

Gyrometer.—A speed indicator. (See *Indicator, Speed.*)

H

H.—A contraction for the horizontal intensity of the earth's magnetism.

H.—A contraction proposed for one unit of self-induction.

H.—A contraction used in mathematical writings for the magnetizing force that exists at any point, or, generally, for the intensity of the magnetic force.

The letter H, when used in mathematical writings or formulæ for the intensity of the magnetic force, is always represented in bold or heavy faced type, thus : **H**.

H-Armature Core.—(See *Core, Armature, H.*)

Hail, Assumed Electric Origin of — — A hypothesis, now generally rejected, framed to explain the origin of the alternate coatings of ice and snow in a hail stone, by the alternate electric attractions and repulsions of the stones between neighboring, oppositely charged, snow and rain clouds.

It is now generally recognized that the electric manifestations attending hail storms are the effects and not the causes of the hail. (See *Paragrèles.*)

Hair, Electrolytic Removal of — — The permanent removal of hair from any part

of the body, by the electrolytic destruction of the hair follicles.

A platinum negative electrode is inserted in the hair follicle and the positive electrode, covered with moist sponge or cotton, is held in the hand of the patient. A current of from two to four *milli-amperes* from a battery of from eight to ten Leclanché elements is then passed for from ten to thirty seconds. A few bubbles of gas appear, and the hairs are then removed from the follicles by a pair of forceps. (See *Milli-Ampère.*)

When the work is properly done there is no destruction of the skin and therefore no marks or scars.

In the removal of hair from the face, it is preferable that the current should slowly reach its maximum strength.

Half-Shades for Incandescent Lamps. —Shades for incandescent electric lamps, in which one-half of the lamp chamber proper is covered with a coating of silver, or other reflecting surface for reflecting the light, or is ground for the purpose of diffusing the light.

The half-shade is applicable to cases where it is desired to throw out the light, not in all directions, but on one side only of any plane. Sometimes the dividing plane is taken parallel to the length of the incandescing filament and sometimes at right angles to it. When the lamp is placed

within a surrounding globe the reflecting surface may be placed on this globe instead of on the lamp chamber.

Hall Effect.—(See *Effect, Hall*.)

Halleyan Lines.—(See *Lines, Halleyan*.)

Halpine-Savage Torpedo.—(See *Torpedo, Halpine-Savage*.)

Handhole of Conduit.—A box or opening communicating with an underground cable, provided for readily tapping the cable, and of sufficient size to permit of the introduction of the hand.

Hand-Lighting Argand Electric Burner.—(See *Burner, Argand Electric, Hand-Lighter*.)

Hand-Lighting Electric Burner.—(See *Burner, Hand-Lighting Electric*.)

Hand-Regulation.—(See *Regulation, Hand*.)

Hand-Regulator.—(See *Regulator, Hand*.)

Hanger-Board.—(See *Board, Hanger*.)

Hanger, Cable — —A hanger or hook suitably secured to the cable and designed to sustain the weight of the cable by intermediately supporting it on iron or steel wires strung above the cable.

A cable hanger or cable clip is shown in Fig. 290. The mode of supporting the cable C, by the hanger hook H, will be readily understood from an inspection of the figure.

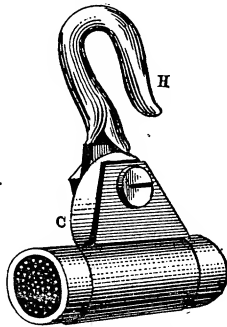

Fig. 290. Cable Hanger.

The weight per foot of an aerial cable is generally so great that the poles or supports would require to be very near together, unless the device of intermediate supports, by means of cable clips or hangers, were adopted.

Hanger, Double-Curve Trolley — —A trolley hanger generally employed at the ends of single and double curves, and on intermediate points on double track curves, supported by lateral strain in opposite directions.

Hanger, Single-Curve Trolley — —A trolley hanger supported on a single track curve, except at the ends and on the inside curve of a double track line, by lateral strain in one direction.

Hanger, Straight-Line Trolley — —A trolley hanger on a straight trolley line suitably supported by a span wire so as to have a vertical strain only.

Hanger, Trolley — —A device for supporting and properly insulating trolley wires.

Hard-Drawn Copper Wire.—(See *Wire, Copper, Hard-Drawn*.)

Harmonic Receiver.—(See *Receiver, Harmonic*.)

Harmonic Telegraphy.—(See *Telegraphy, Gray's Harmonic Multiple*.)

Head Bath, Electric — —(See *Bath, Head, Electric*.)

Head Breeze, Electro-Therapeutic — —(See *Breeze, Head, Electro-Therapeutic*.)

Head Light, Locomotive, Electric — —An electric light placed in the focus of a parabolic reflector in front of a locomotive engine.

The lamp is so placed that its voltaic arc is a little out of the focus of the reflector, so that, by giving a slight divergence to the reflected light, the illumination extends a short distance on either side of the tracks.

Heat.—A form of energy.

The phenomena of heat are due to a vibratory motion impressed on the molecules of matter by the action of some form of energy.

Heat in a body is due to the vibrations or oscillations of its molecules. Heat is transmitted through space by means of a wave motion in the universal ether. This wave motion is the same as that causing light.

A hot body loses its heat by producing a wave motion in the surrounding ether. This process is called *radiation*. (See *Radiation*.)

The energy given off by a heated body cooling is called radiant energy.

Radiant energy is transmitted by means of ether waves; it is of two kinds, viz.:

(1.) *Obscure Heat*, or heat which does not affect the eye, although it can impress a photographic image on a sufficiently sensitive photographic plate.

(2.) *Luminous Heat*, or heat which accompanies light. (See *Energy, Radiant*.)

Heat is conducted, or transmitted through bodies, with different degrees of readiness.

Some bodies are good conductors of heat, others are poor conductors.

Heat is transmitted through liquids by means of currents occasioned by differences in density caused by differences of temperature. These currents are called *convection currents*.

Heat is measured as to its *relative degree of intensity* by the *thermometer*. It is measured as to its *amount* or *quantity* by the *calorimeter*. (See *Thermometer, Electric. Calorimeter*.)

The heat unit most commonly employed is, perhaps, the *calorie*, or the amount of heat required to raise one gramme of water one degree centigrade.

Another *heat unit*, very generally employed in the United States and England, is the quantity of heat required to raise one pound of water one degree Fahrenheit. This is called the English heat unit. (See *Calorie. Units, Heat. Joule. Volt-Coulomb*.)

Heat, Absorption and Generation of, in Voltaic Cell — — The heat effects which attend the action of a voltaic cell.

The chemical action of the exciting liquid or electrolyte on the positive plate or element of a voltaic cell, like all cases of chemical combination, is attended by a development of heat.

When, however, the circuit of the cell is closed, the energy liberated during the chemical combination appears as electricity, which develops heat in all parts of the circuit. (See *Heat, Electric. Cell, Voltaic*.)

Heat, Atomic — — A constant product obtained by multiplying the specific heat of an elementary substance by its *atomic weight*. (See *Weight, Atomic*.)

Dulong and Petit have discovered the remarkable fact that the product of the specific heat of all elementary substances by their atomic weights is nearly the same. The product is called the *atomic heat*, and is about equal to 6.4.

Dulong and Petit's law may be stated as follows, viz.: *All elementary atoms require the same quantity of heat to heat them to the same number of degrees.*

The atomic heat of any body divided by its specific heat gives its atomic weight.

The heat imparted to any body performs three kinds of work, viz.:

(1.) That expended in external work, such, for example, as in overcoming the atmospheric pressure.

(2.) That expended in internal work, or in overcoming the attractions of the atoms and driving them apart.

(3.) That expended in overcoming the temperature, or the true specific heat, or heat expended in increasing the molecular vis-viva.

The expenditure of energy is greatest in the third head. The exact value of the three factors is as yet unknown, and in the opinion of Weber and others the correctness of Dulong and Petit's law cannot be regarded as being satisfactorily established.

Regnault has proved that Dulong and Petit's law is true for compound bodies, *i. e.*, in all compounds of similar composition the product of the specific heat by the total chemical equivalent is constant.

The following table from Anthony and Bracket illustrates the law of Dulong and Petit:

Elements.	Specific Heat of Equal Weigh..	Atomic Weight.	Product of Specific Heat into Atomic Weight.
Iron.....	0.114	55.9	6.372
Copper.....	0.095	63.17	6.001
Mercury.....	0.0314 (Solid)	199.71	6.128
Silver.....	0.057	107.67	6.137
Gold.....	0.0329	196.15	6.453
Tin.....	0.056	117.7	6.591
Lead.....	0.0314	206.47	6.483
Zinc.....	0.0955	64.9	6.198

“This product—the atomic heat of elements, the molecular heat of compounds—has the following physical meaning: Of any substance whose atomic or molecular weight we know, we may take a number of grammes numerically equal to the atomic or molecular weight; for example, 35.5 grammes of chlorine, 16 grammes of marsh gas; we may call such quantity the gramme atom or the gramme molecule of the substance. The atomic heat or the molecular heat of a substance is the number of calories of heat necessary to raise the temperature of a gramme atom or a gramme molecule of the substance through 1 degree C.”—(Daniell.)

Heat, Electric — — The heat developed by the passage of an electric current through a conductor.

Heat is developed by the passage of a current through any conductor, no matter what its resistance may be.

If the conductor is of considerable length, and of good conducting power, the heat developed is not very sensible, since it is spread over a considerable area, and is rapidly lost by radiation.

H, the heat generated in any conductor of a resistance R, by the passage through it of an electric current C, is equal to

$$H = C^2 R, \text{ in watts.}$$

But one watt = .24 small calorie per second.

Therefore, the heat which is generated,

$$H = C^2 R \times .24 \text{ calories per second.}$$

For the case of a uniform wire of circular cross-section the resistance R, in ohms is directly proportional to the length l, and inversely proportional to the area of cross-section πr^2 , or

$$R = \frac{l}{\pi r^2}; \text{ that is, } H = C^2 \left(\frac{l}{\pi r^2} \right).$$

The temperature to which a wire of a given resistance is raised, will of course vary with the mass of the wire, its radiating surface, and its specific heat capacity. If the same number of heat calories are generated in a small weight of a conductor, whose radiating surface is small, the resulting temperature will of course be far higher than if generated in a larger mass provided with a much greater radiating surface. In general, however, its temperature increases as the square of the current strength when the resistance is constant, and increases as the resistance of the wire per unit of length is greater.

The temperature a wire acquires by the passage of a current through it varies inversely as the third power of the radius. If two wires of the same material have the same lengths, but different radii, the temperature, acquired by the passage of an electric current, will depend on the heat developed per second, less that radiated per second. Since the former varies as $\frac{I}{r^2}$, and the latter as r, that is, as $l \times 2\pi r$, the temperatures attained vary as $\frac{I}{r^3}$, and not as $\frac{I}{r^2}$, as frequently stated.—(Larden.)

The current required to raise the temperature of a bare copper wire a given number of degrees above the temperature of the air is given in the following table :

BARE COPPER WIRES.

Current required to increase the temperature of a copper wire t° Centigrade above the surrounding air, the copper wire being bright polished or blackened.

Diameter in Centimetres and Mils (thousandths of an inch).		CURRENT IN AMPÈRES.					
		t = 1° C.		t = 9° C.		t = 25° C.	
Cm.	Mils.	Bright	Black	Bright	Black	Bright	Black
.1	40	1.0	1.4	3.0	4.1	4.8	6.6
.2	80	2.8	3.9	8.3	11.5	13.5	18.7
.3	120	5.2	7.2	15.3	21.2	24.9	34.4
.4	160	8.0	11.0	23.6	32.7	38.3	53.0
.5	200	11.1	15.4	33.0	45.7	53.5	74.1
.6	240	14.6	20.3	43.4	60.0	70.3	97.4
.7	280	18.5	25.6	54.6	75.6	88.7	123
.8	310	22.6	31.3	66.7	92.4	108	150
.9	350	26.9	37.3	79.6	110	129	179
1.0	390	31.5	43.6	93.3	129	151	210
2.0	790	89.2	123	264	365	428	593
3.0	1180	164	227	485	671	787	1090
4.0	1570	252	349	746	1035	1211	1675
5.0	1970	353	488	1043	1444	1699	2343
6.0	2360	463	642	1371	1828	2225	3080
7.0	2760	584	808	1728	2392	2803	3882
8.0	3150	714	988	2110	2922	3422	4741
9.0	3540	851	1178	2519	3486	4088	5659
10.0	3940	997	1380	2950	4084	4788	6626
34.4

Diameter in Centimetres and Mils (thousandths of an inch).		CURRENT IN AMPÈRES.			
		t = 49° C.		t = 81° C.	
Cm.	Mils.	Bright.	Black.	Bright.	Black.
.1	40	6.5	8.9	7.9	11.0
.2	80	18.3	25.3	22.4	31.0
.3	120	33.5	46.4	41.2	57.0
.4	160	51.7	71.5	63.4	87.8
.5	200	72.2	99.9	88.6	123
.6	240	94.9	131	116	161
.7	280	119	165	147	203
.8	310	146	202	179	248
.9	350	174	241	214	296
1.0	390	204	283	251	347
2.0	790	577	769	709	931
3.0	1180	1061	1468	1303	1805
4.0	1570	1633	2260	2066	2776
5.0	1970	2283	3160	2802	3880
6.0	2360	3000	4154	3685	5100
7.0	2760	3781	5233	4642	6426
8.0	3150	4620	6396	5671	7850
9.0	3540	5511	7630	6769	9370
10.0	3940	6425	8935	7926	10973
34.4	70000

—(Forbes.)

Heat, Electric Convection of — — A term employed to express the dissymmetrical distribution of temperature that occurs when a

current of electricity is sent through a metallic wire, the middle of which is maintained at a constant temperature, and the ends at the temperature of melting ice.

The distribution of heat during the passage of a current through an unequally heated conductor.

If the central portions of a metallic bar are heated the curve of heat distribution is symmetrical. On sending an electric current through the wire it is heated according to Joule's law, and the curve of heat distribution is still symmetrical. But the current in passing from the colder to the hotter parts of the wire produces an additional heating effect at this point, and in passing from the warmer to the colder parts of the wire produces a cooling effect. (See *Effect, Peltier. Effect, Thomson.*) The curve of heat distribution is then no longer symmetrical. The term *Electrical Convection of Heat*, has been given to the dissymmetrical distribution of heat so effected.

Sir William Thomson, who studied these effects, found that the electrical convection of heat in copper takes place in the opposite direction to that in iron; that is to say, the electrical convection of heat is negative in iron, (*i. e.*, the direction is opposite to that of the current), and positive in copper.

Heat, Irreversible — — Heat produced in a homogeneous conductor by the passage of electricity through it.

This heat, according to Joule's law, is proportional to the square of the current, and is produced no matter in what direction the current is passing. In this respect it is unlike the heat produced by the passage of electricity through a heterogeneous conductor, in which case heat is developed or liberated only by the passage of the current in a given direction: on the passage of the current in the opposite direction, heat being absorbed and the temperature lowered. (See *Heat, Reversible.*)

Heat Lightning.—(See *Lightning, Heat.*)

Heat, Luminous — — A variety of radiant energy which affects the eye, as light.

Radiant heat and light are, in reality, different effects produced by one and the same cause, *viz.*, by vibrations or waves in the universal ether. In general the waves producing heat are of

greater length and smaller frequency than are those producing light.

Heat, Mechanical Equivalent of. — — The amount of mechanical energy, converted into heat, that would be required to raise the temperature of 1 pound of water 1 degree Fahr.

The mechanical equivalence between the amount of energy expended and the amount of heat produced, as measured in heat units.

Joule's experiments, the results of which are generally accepted, gave 7.2 foot-pounds as the energy equivalent to that expended in raising the temperature of 1 pound of water 1 degree Fahr.

Heat, Molecular — — The number of calories of heat required to raise the temperature of one gramme-molecule of any substance 1 degree C. (See *Molecule, Gramme. Heat, Atomic.*)

Heat, Obscure — — A variety of radiant energy which does not effect the eye.

Radiant heat is sometimes divided into luminous heat and obscure heat. (See *Heat, Luminous.*)

Heat, Red — — The temperature at which a body, whose temperature is gradually increasing, begins to glow or to emit red rays of light.

When a refractory solid body is gradually heated to incandescence, the red waves of light are first emitted, then the orange, and successively afterwards the yellow, green, blue, indigo and violet, when the body emits white light or is white hot.

Heat, Reversible — — The heat produced in a heterogeneous conductor by the passage through it of an electric current in a certain direction.

Reversible heat is produced at the junction of two metals, where a difference of potential exists between them, or where their heterogeneity is greatest. It is called reversible because it depends upon the direction in which the current is passing. If the current be passed in a certain direction across the junction, heat is liberated; while, if it be passed in the opposite direction, heat is absorbed, or cold results.

Reversible heat effects are seen in the Peltier effect. (See *Effect, Peltier.*)

Heat, Specific — —The capacity of a substance for heat as compared with the capacity of an equal quantity of some other substance taken as unity.

Water is generally taken as the standard for comparison, because its capacity for heat is greater than that of any other common substance.

Different quantities of heat are required to raise the temperature of a given weight of different substances through 1 degree. The specific heats of substances are generally compared with water or with hydrogen, the capacity of these substances for heat being very great.

According to Dulong and Petit, the specific heat of all elementary atoms is the same. For example, the heat energy of an atom of hydrogen is equal to that of an atom of oxygen, but since a given mass of hydrogen, under similar conditions of temperature and pressure, contains sixteen times as many atoms as an equal mass of oxygen, therefore, when compared weight for weight, hydrogen has a specific heat sixteen times greater than that of oxygen.

Or, in general, comparing equal weights, the specific heat of an elementary substance is inversely proportional to its atomic weight. (See *Heat, Atomic.*)

Heat, Specific, of Electricity — —(See *Electricity, Specific Heat of.*)

Heat Unit.—The quantity of heat required to raise a given weight of water through a single degree.

There are a number of different heat units. The most important are:

(1.) The British Heat Unit, or Thermal Unit, or the amount of heat required to raise 1 pound of water 1 degree Fahr. This unit represents an amount of work equal to 772 foot-pounds.

(2.) The Greater Calorie, or the amount of heat required to raise the temperature of 1,000 grammes of water 1 degree C. (See *Calorie.*)

(3.) The Smaller Calorie, or the amount of heat required to raise the temperature of one gramme of water 1 degree C.

(4.) The Joule, or the quantity of heat developed in one second by the passage of a current of one ampère through a resistance of one ohm.

1 joule equals .0002407 large calories.

1 joule equals .2407 small calories.

1 foot-pound equals 1.356 joules.

1 pound-Centigrade equals 1884.66 joules.

1 " " " " 1389.6 foot-pounds.

1 " Fahrenheit " " 1047.03 joules.

Heat Unit, English — —(See *Units, Heat.*)

Heat Unit or Calorie.—(See *Calorie.*)

Heat Unit or Joule.—(See *Joule.*)

Heat, White — —The temperature at which light of all wave lengths from the red to the violet is emitted from a heated body, and the body, therefore, glows with a white light.

A solid substance heated to white incandescence emits a continuous spectrum, *i. e.*, a spectrum in which all the wave lengths of light from the red to the violet are present.

Heater, Electric — —A device for the conversion of electricity into heat for purposes of artificial heating.

Electric heaters consist essentially of coils or circuits of some refractory metal through which the current is passed. These coils or circuits are surrounded by air or finely divided solids, and are placed inside metallic boxes or radiators, which throw off or radiate the heat produced.

When employed for the heating of liquids the coils are placed directly in the liquid to be heated, or are surrounded by radiating boxes placed in the liquid.

Heating Effects of Currents.—(See *Currents, Heating Effects of.*)

Hedgehog Transformer.—(See *Transformer, Hedgehog.*)

Hecto-Ampère — —One hundred ampères.

Heliograph.—An instrument for telegraphic communication that operates by employing flashes of light to represent the dots and dashes of the Morse alphabet, or the movements of the needles of a needle telegraph to the right or the left. (See *Alphabet, Telegraphic.*)

The flashes of light are thrown from the surface of a plane mirror. Motions to the right or left may be employed in order to distinguish between the dots and dashes, or the same may be effected by the relative durations of the flashes of

light, or by the intervals between successive flashes.

Telegraphic communication has been carried on between steamers during foggy weather by means of their fog horns; or between locomotives by their steam whistles.

Helix, Dextrorsal — — A name sometimes applied to a dextrorsal solenoid. (See *Solenoid, Dextrorsal*.)

The magnetic polarity of a helix or solenoid depends not only on the direction in which the current is passed, but also on the direction in which the wire is coiled or wound. (See *Magnet, Electro*.)

Helix, Sinistrorsal — — A name sometimes applied to a sinistrorsal solenoid. (See *Solenoid, Sinistrorsal*.)

Hemihedral Crystal.—(See *Crystal, Hemihedral*.)

Henry, A — — The practical unit of self-induction.

It has been generally agreed in the United States to call the practical unit of self-induction a henry, in place of a secohm or quadrant. The name henry should be adopted, not only by American electricians, but also by those of other countries, since the terms secohm or quadrant are contrary to the generally adopted usage of employing for such the names of distinguished electricians, who have passed from their labors.

The fact that of all discoverers in the field of self-induction, none possesses so great a claim as that of Prof. Henry, must be generally acknowledged. As early as 1832 he published in *Silliman's Journal* a paper in which he described experiments, showing clearly that the spark obtained by breaking the current of a battery, in which a long wire was interposed, was greater than when a short wire was employed, and that this increased length of spark was further increased by coiling the wire, and that the phenomena were ascribed to the action of the current on itself.

A committee of the American Institute of Electrical Engineers, after careful consideration, recommended to the Institute that the value of the practical unit of inductance should be equal to 10⁹ C. G. S. units of inductance, usually expressed by a length equal to one earth quadrant or 1,000,000,000 centimetres.

The value of the practical unit of inductance, or the "henry," may in some cases be too high for

convenience; in such cases it may be expressed by some fractional dimension, such, for example, as milli-henry.

Hercules Stone.—(See *Stone, Hercules*.)

Hermetical Seal.—(See *Seal, Hermetical*.)

Hertz's Theory of Electricity.—(See *Electricity, Hertz's Theory of*.)

Heterostatic.—A term applied by Sir William Thomson to distinguish a form of electrometer in which the electrification is measured by determining the mutual influence of the attraction exerted by the charge to be measured and the attraction of an opposite charge imparted to the instrument by a source independent of the charge to be measured.

The term heterostatic distinguishes this form of electrometer from an idiostatic instrument, or one in which the measurement is effected by determining the repulsion between the charge to be measured and the repulsion of a charge of the same name, *i. e.*, positive or negative, imparted to the instrument from an independent source. (See *Electrometer*.)

Hick's Automatic Button Repeater.—(See *Repeaters, Telegraphic*.)

High-Bars.—A term applied to those commutator segments, or parts of commutator segments, which, through less wear, faulty construction or looseness, are higher than adjoining portions. (See *Commutator*.)

High-Frequency Currents, Electric Lighting by — — (See *Lighting, Electric, by High-Frequency Currents*.)

High Resistance Magnet.—(See *Magnet, High Resistance*.)

High Speed Electric Motor.—(See *Motor, Electric, High Speed*.)

High Tension Electric Fuse.—(See *Fuse, Electric High Tension*.)

Hissing of Arc.—(See *Arc, Hissing of*.)

Holder for Safety Fuse.—A box or other receptacle of refractory material for holding a safety fuse, and catching the molten metal when fused.

The holder or fuse box is provided to prevent the

molten metal of the fuse from setting fire to any combustible material on which it might otherwise fall.

Holders, Carbon, for Arc Lamps — — A clutch or clamp attached to the end of the lamp rod or other support, and provided to hold the carbon pencils used on arc lamps. (See *Lamp, Arc, Electric.*)

Holders for Brushes of Dynamo-Electric Machine.—A device for holding the collecting brushes of a dynamo-electric machine.— (See *Machine, Dynamo-Electric.*)

Hole, Armature — — A term sometimes applied for armature bore or chamber. (See *Bore, Armature.*)

Hole, Armature Bore, Elliptical — — An armature bore or chamber ellipsoidal in shape.

Holohedral Crystal.—(See *Crystal, Holohedral.*)

Holtz Machine.—(See *Machine, Holtz.*)

Home Station.—(See *Station, Home.*)

Homogeneous Current Distribution.— (See *Current, Homogeneous Distribution of.*)

Hood for Electric Lamp.—A hood provided for the double purpose of protecting the

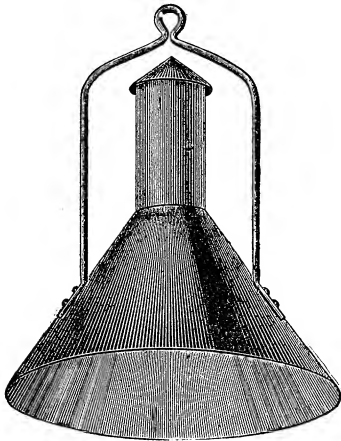

Fig. 291. Arc Lamp Hood.

body of an electric lamp from rain or sun, and for throwing its light in a general downward direction.

Hoods for arc lamps are generally conical in shape.

A form of hood for an exposed arc lamp is shown in Fig. 291.

Horizontal Component of Earth's Magnetism.—(See *Component, Horizontal, of Earth's Magnetism.*)

Horns, Following, of Pole Pieces of a Dynamo-Electric Machine — — The edges or terminals of the pole pieces of a dynamo-electric machine towards which the armature is carried during its rotation.

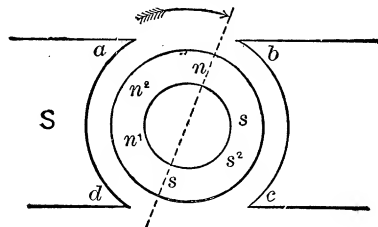

Fig. 292. Horns of Dynamo.

According to S. P. Thompson, the following horns, b, d, Fig. 292, are those towards which the armature is carried; the leading horns, a, c, those from which it is carried.

As the change in the magnetic intensity is more sudden when the armature is moved from the pole pieces, and least when moved towards them, it is clear that the leading horns in a dynamo-electric machine, and the following horns in an electric motor, become heated during rotation by the production of Foucault currents. (See *Currents, Foucault. Machine, Dynamo Electric.*)

Horns, Leading, of Pole Pieces of a Dynamo-Electric Machine — — The edges or terminals of the pole pieces of a dynamo-electrical machine from which the armature is carried during its rotation.

Thus, in Fig. 292, a and c, are the leading horns of the pole pieces.

Horns of Pole Pieces of Dynamo-Electric Machine.—The edges of the pole pieces of a dynamo-electric machine towards or from which the armature is carried during its rotation.

These are called the following and the leading horns.

Horse-Power.—A commercial unit for power or rate of doing work.

A rate of doing work equal to 33,000 pounds raised 1 foot per minute, or 550 pounds raised 1 foot per second.

A rate of doing work equal to 4,562.33 kilogrammes raised 1 metre per minute.

A careful distinction must be drawn between work and power. The same amount of work is done in raising 1 pound through 10 feet whether it be done in one minute or in one hour. The power expended or the rate of doing work is, however, quite different, being in the former case sixty times greater than in the latter.

1 horse-power = 550 foot-pounds per second.

“ = 33,000 foot-pounds per minute.

“ = 4,562.33 kilogramme-metres per minute.

“ = 745,941 watts.

“ = 1.01385 metric horse-power.

Horse-Power, Electric — (See *Power, Horse, Electric*.)

Horse-Power Hour.—(See *Hour, Horse-Power*.)

Horse-Power, Metric — —A unit of power in which rate of doing work is equal to 75 kilogramme-metres. (See *Horse-Power*.)

Horseshoe Electro-Magnet.—(See *Magnet, Electro, Horseshoe*.)

Horseshoe Magnet.—(See *Magnet, Horseshoe*.)

Hot, Red — —Sufficiently heated to emit red light only. (See *Heat, Red*.)

Hot St. Elmo's Fire.—(See *Fire, Hot, St. Elmo's*.)

Hot, White — —Sufficiently heated to emit all the colored lights of the spectrum. (See *Heat, White*.)

Hotel Annunciator.—(See *Annunciator, Hotel*.)

Hour, Ampère — —A unit of electrical quantity equal to one ampère flowing for one hour.

The ampère-hour is in reality a unit of quantity like the coulomb. It is used in the service of electric currents, and is equal to the product of the current delivered by the time in hours. The ampère-hour is not a measure of energy, but when

combined with the volt, and expressed in watt hours, it is a measure of energy.

The capacity of any service for maintaining a flow of current is measured in ampère-hours. Thus, if any service, such as a primary or secondary battery, has a capacity of 80 ampère-hours, it will supply 8 ampères for ten hours, or it may give 10 ampères for eight hours.

The storing capacity of accumulators is generally given in ampère-hours. The same is true of primary batteries.

One coulomb equals .0002778 ampère-hours.

One ampère-hour equals 3,600 coulombs.

Hour, Horse-Power — —A unit of work. An amount of work equal to one horse-power for an hour.

One horse power is equal to 1,980,000 foot-pounds, or 745.941 watt hours.

Hour, Kilo-Watt — —A unit of electrical power equal to a kilo-watt maintained for one hour.

Hour, Lamp — —Such a service of electric current as will maintain one electric lamp during one hour.

The number of lamp-hours is obtained by multiplying the number of lamps by the average number of hours during which the lamps are burning.

The use of lamp-hours is for the purpose of estimating the current supplied to a consumer by counting the number of hours each lamp is in service.

To convert lamp-hours to watt-hours, multiply the number of lamp-hours by the number of watts per lamp. The watt hours, divided by 746, will then give the electrical horse-power hours. (See *Hour, Watt*.)

Hour, Watt — —A unit of electrical work.

An expenditure of an electrical work of one watt for one hour.

Lamp-hours are converted to watt-hours by multiplying the number of lamp-hours by the number of watts per lamp. (See *Hour, Lamp*.)

House Annunciator.—(See *Annunciator, House*.)

House Main.—(See *Main, House*.)

House-Service Conductor.—(See *Conductor, House-Service*.)

House-Top Fixtures, Telegraphic — —
(See *Fixtures, Telegraphic House-Top*.)

House Wire.—(See *Wire, House*.)

Hughes' Electro-Magnet.—(See *Magnet, Electro, Hughes'*.)

Human Body, Electric Resistance of — —
(See *Body, Human, Resistance of*.)

Hydro-Electric Bath.—(See *Bath, Hydro-Electric*.)

Hydro-Electric Machine, Armstrong's — —
(See *Machine, Armstrong's Hydro-Electric*.)

Hydrogen, Electrolytic — —Hydrogen produced by electrolytic decomposition.

It is the electrolytic hydrogen liberated in a voltaic cell at the surface of the negative plate, which causes polarization and consequent decrease in the resulting current strength, by reason both of the counter-electromotive force it produces and the increased resistance it produces in the cell.

Electrolytic hydrogen is atomic hydrogen; *i. e.*, hydrogen with its bonds open or free. It therefore possesses much stronger chemical affinities than does molecular hydrogen. Electrolytic oxygen which is evolved at the same time as the electrolytic hydrogen has been successfully employed in electric bleaching. Hydrogen peroxide is also formed and acts as a bleaching agent.

Hydrometer or Areometer.—An apparatus for determining the specific gravity of liquids. (See *Areometer or Hydrometer*.)

Hydro-Plastics.—(See *Plastics, Hydro*.)

Hydro-Plasty.—The art of hydro-plastics. (See *Plastics, Hydro*.)

Hydrotasimeter, Electric — —An electrically operated apparatus designed to show at a distance the exact position of any water level.

In most forms of the electric hydrotasimeter a float placed in the liquid and connected with an electric circuit breaks this circuit, and, at intervals, sends positive impulses into the line when rising and negative impulses when falling. These are registered by means of an index moved by a step-by-step motion, positive currents moving it in one direction and negative currents moving it in the opposite direction.

Hygrometer.—An apparatus for determining the amount of moisture in the air.

Hygrometrical.—Of or pertaining to the hygrometer.

Hygrometrically.—In the manner of the hygrometer.

Hypothesis.—A provisional assumption of facts or causes the real nature of which is unknown, made for the purpose of studying the effects of such causes.

When the facts assumed by a hypothesis can be shown to be presumably true the hypothesis becomes a theory. A theory, therefore, gives a more correct expression of the relations between the causes and effects of natural phenomena than does a hypothesis.

Hypothesis, Double-Fluid Electric — —
(See *Electricity, Double-Fluid Hypothesis of*.)

Hypothesis, Grothüss' — —A hypothesis proposed by Grothüss to account for the electrolytic phenomena that occur on closing the circuit of a voltaic cell.

Grothüss' hypothesis assumes:

(1.) That before the electric circuit is closed the molecules of the electrolyte are arranged in an irregular or unpolarized condition, as repre-

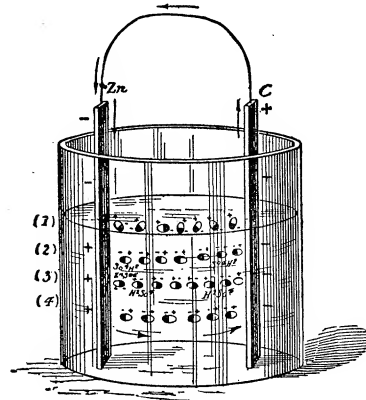

Fig. 293. Grothüss' Hypothesis of Electrolytic Polarization.

sented at (1), Fig. 293. These molecules are shaded as shown in Fig. 294, to indicate their composition and polarity.

(2.) When the circuit is closed and a current

begins to pass, a polarization of the electrolyte, as shown at (2), ensues, whereby all the negative ends of the molecules of hydrogen sulphate, or sulphuric acid, are turned towards the positive or zinc plate, and all the positive ends towards the negative or copper plate. This, as will be seen, will turn the SO_4 ends towards the zinc, and the H_2 ends towards the copper.

(3.) A decomposition of the polarized chain, whereby the SO_4 unites with the zinc and the H_2 liberated reunites with the SO_4 of the molecule next to it in the chain, and its liberated H_2 with the one next to it, and so on until the last liberated H_2 in the chain is given off at the surface of the copper or negative plate. This leaves the chain of molecules as shown at (3).

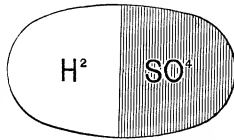

Fig. 294. Conventionalized Molecule.

(4.) A semi-rotation of the molecules of the chain, as at (3), until they assume the position shown at (4). This rotation is required, since all the molecules in (3) are turned with their similar poles towards similarly charged battery plates.

Hypothesis, Single-Fluid Electric —
—(See *Electricity, Single-Fluid Hypothesis of.*)

Hypothetical.—Of or pertaining to a hypothesis.

Hypsometer.—An apparatus for determining the height of a mountain or other elevation by ascertaining the exact temperature at which water boils at such elevation.

The use of a thermometer to measure the height of a mountain or other elevation is based on the fact that a given decrease in the temperature of the boiling point of water invariably attends a given decrease in the atmospheric pressure. Therefore, as the observer goes further above the level of the sea, the boiling point of water becomes lower, and from this decrease the height of the mountain or other elevation may be calculated.

Hypsometrical.—Of or pertaining to the hypsometer.

Hypsometrically.—In the manner of the hypsometer.

Hysteresial Dissipation of Energy.—(See *Energy, Hysteresial Dissipation of.*)

Hysteresis.—Molecular friction to magnetic change of stress.

A retardation of the magnetizing or demagnetizing effects as regards the causes which produce them.

The quality of a paramagnetic substance by virtue of which energy is dissipated on the reversal of its magnetization.

The ratio of magnetic induction to the magnetizing force producing it, or, in other words, the magnetic permeability, is greater when the magnetizing force is decreasing, than when it is increasing. This phenomenon is seen in the well known retention of magnetism in iron after the withdrawal of the force causing the magnetization, and was called by Ewing *hysteresis*, from $\nu\sigma\tau\epsilon\rho\acute{\epsilon}\omega$, to lag behind.

If a curve is constructed in which the horizontal abscissas represent the magnetizing force, or the magnetizing current to which they are proportional, and the vertical ordinates the number of lines of induction passing through the body that is being magnetized, both in the case of gradually increasing and gradually decreasing currents, the curve will be found to have greater values for the decreasing than for the increasing current. Constructing a curve in this manner for the case of a ring of iron, which has been first suddenly magnetized and then demagnetized, taking the magnetizing force along the line F H, Fig. 295, and the resulting magnetization along the line M N, a loop is formed in the curve, as shown in the figure.

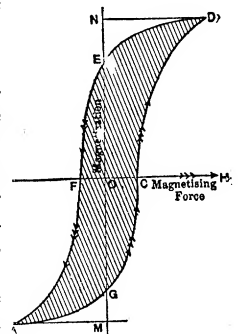

Fig. 295. Curves of Hysteresis (Ewing). The shaded area the work done due to hysteresis.

The area of this loop represents the amount of energy per unit of volume expended in performing a magnetic cycle, *i. e.*, in carrying the iron ring through a magnetization and subsequent demagnetization.

The physical meaning of the loop is that a lag-

ging of magnetization has occurred. This lagging of the magnetization is due to hysteresis.

Ewing gives the value for the energy in ergs dissipated per cubic centimetre, for a complete magnetic cycle for a number of substances, as follows :

Sample of Iron operated upon.	Energy dissipated in ergs per cubic centimetre, during a complete cycle of doubly reversed strong magnetization.
Very soft annealed iron.....	9,300 ergs.
Less soft annealed iron.....	16,300 "
Hard drawn steel wire.....	60,000 "
Annealed steel wire.....	70,500 "
Same steel, glass hard.....	76,000 "
Piano-forte steel wire, normal temper.....	116,000 "
Same, annealed.....	94,000 "
Same, glass hard.....	117,000 "

Approximately 28 foot-pounds of energy are required to make a double reversal of strong magnetization in a cubic foot of iron. Energy expended in this way takes the form of heat. This heat, however, is to be distinguished from heat produced by Foucault currents.

According to Ewing, hysteresis is greatly decreased by keeping the iron in a state of magnetic vibration. In this way, the energy dissipated in a complete magnetic cycle is correspondingly decreased. This observation of Ewing agrees with the prior observation of Hughes, who noticed that tapping or twisting a bar of iron greatly accelerates the removal of its residual magnetism.

The phenomena of hysteresis, according to Fleming, accounts for part of the energy which is dissipated in a dynamo-electric machine:

(1.) In the field magnets.

In an ordinarily constructed continuous-current dynamo, work is done in magnetizing the field magnets, not only to give the iron its initial magnetism, but also to constantly reproduce the magnetism which the machine loses by reason of the

continual vibrations to which it is subjected during its run. If sufficient residual magnetism were retained, on the withdrawal of the magnetizing force there would be no necessity for the current in the field magnets; but, since this is removed by even a small vibration, the energy of the exciting current must needs be expended.

(2.) In the armature of the dynamo.

The soft iron of the core is subjected to successive magnetizations and demagnetizations. According to Fleming, in the case of a core having a volume of 9,000 cubic centimetres, with fifteen reversals per second, the loss is equal to about $\frac{1}{4}$ horse-power.

Hysteresis, Static — — That quality in iron, or other paramagnetic substance, by virtue of which energy is dissipated during every reversal of its magnetization.

Static hysteresis is so named in order to distinguish it from viscous hysteresis. (See *Hysteresis, Viscous*.)

Hysteresis, Viscous — — The time-lag observed in magnetizing a bar of iron, which is referable neither to induction in the iron, nor to self-induction in the magnetizing current, but to the magnetic viscosity of the substance.

A sluggishness exhibited by iron for magnetization or demagnetization due to magnetic viscosity.

The difference between static and viscous hysteresis is thus stated by Fleming in considering the analogous mechanical case of lifting a weight in a viscous fluid. "Apart from fluid resistance, the work done in lifting the weight against gravity, say one hundred times, is a hundred times the work required to be spent to lift it once; but if fluid resistance comes into play, and if this varies as the square of the velocity of the moving body, then the total work done in lifting the weight through the fluid will be dependent also upon the rate at which the cycle is performed."

I

I. H. P.—A contraction for indicated horse-power, or the horse-power of an engine as obtained by the means of an indicator card.

I. W. G.—A contraction for Indian wire gauge.

Idio-Electrics.—A name formerly applied to such bodies as amber, resin or glass, which are readily electrified by friction, and which were then supposed to be electric in themselves.

This distinction was based on an erroneous conception, and the word is now obsolete.

Idiostatic.—A term employed by Sir William Thomson to designate an electrometer in which the measurement is effected by determining the repulsion between the charge to be measured and that of a charge of the same sign imparted to the instrument from an independent source. (See *Heterostatic.*)

Idle Poles.—(See *Poles, Idle.*)

Igniter, Jablochhoff — —A small strip of carbon, or some carbonaceous material that is readily rendered incandescent by the current, placed between the free ends of the parallel carbons of a Jablochhoff candle, for the establishment of the arc on the passage of the current.

The igniter is necessary in the Jablochhoff electric candle, since the parallel carbons are rigidly kept at a constant distance apart by the insulating material placed between them, and cannot therefore be moved together as in the case of the ordinary lamp. (See *Candle, Jablochhoff.*)

Ignition, Electric — —The ignition of a combustible material by heat of electric origin.

The electric ignition of wires is generally accomplished by electric incandescence. Ignition may be accomplished by the heat of the voltaic arc. (See *Heat, Electric. Furnace, Electric.*)

The ignition of combustible gases is accomplished by the heat of the electric spark. (See *Burner, Automatic, Electric.*)

Illumination, Artificial — —The employment of artificial sources of light.

A good artificial illuminant should possess the following properties, viz.:

(1.) It should give a general or uniform illumination as distinguished from sharply marked regions of light and shadow.

To this end a number of small lights well distributed are preferable to a few large lights.

(2.) It should give a steady light, uniform in brilliancy, as distinguished from a flickering, unsteady light. Sudden changes in the intensity of a light injure the eyes and prevent distinct vision.

(3.) It should be economical, or not cost too much to produce.

(4.) It should be safe, or not likely to cause loss of life or property. To this intent it should, if possible, be inclosed in or surrounded by a lantern or chamber of some incombustible material, and should preferably be lighted at a distance.

(5.) It should not give off noxious fumes or vapors when in use, nor should it unduly heat the air of the space it illumines.

(6.) It should be reliable, or not apt to be unexpectedly extinguished when once lighted.

The electric incandescent lamp is an excellent artificial illuminant.

(1.) It is capable of great subdivision, and can, therefore, produce a uniform illumination.

(2.) It is steady and free from sudden changes in its intensity.

(3.) It compares favorably in point of economy with coal oil or gas, provided its extent of use is sufficiently great.

(4.) It is safer than any known illuminant, since it can be entirely inclosed and can be lighted from a distance or at the burner without the dangerous friction match.

The leads, however, must be carefully insulated and protected by safety fuses. (See *Fuse, Safety.*)

(5.) It gives off no gases, and produces far less heat than a gas-burner of the same candle power.

It perplexes many people to understand why the incandescent electric light should not heat the air of a room as much as a gas light, since it is quite as hot as the gas light. It must be remembered, however, that a gas-burner, when lighted, not only permits the same quantity of

gas to enter the room which would enter it if the gas were simply turned on and not lighted, but that this bulk of gas is still given off, and is, indeed, considerably increased by the combination of the illuminating gas with the oxygen of the atmosphere; and, moreover, this great bulk of gas escapes as highly heated gases. Such gases are entirely absent in the incandescent electric light, and consequently its power of heating the surrounding air is much less than that of gas lights.

(6.) It is quite reliable, and will continue to burn as long as the current is supplied to it.

Illumination, Lighthouse, Electric —
—The application of the electric arc light to lighthouses.

A powerful arc light is placed in the focus of the dioptric lens now commonly employed in lighthouses. Since the consumption of the carbon electrodes would alter the position of the focus of the light, electric lamps for such purposes are constructed to feed both of their carbons, instead of the upper carbon only, as in the case of the ordinary arc lamp. Such lamps are called focusing lamps.

Illumination, Unit of — —A standard of illumination proposed by Preece, equal to the illumination given by a standard candle at the distance of 12.7 inches.

According to Preece, the illumination of the average streets of London, where gas is employed, is equal to about one-tenth of this standard in the neighborhood of a gas lamp, and about one-fiftieth in the middle space between two lamps.

The term unit of illumination, in place of intensity of light, was proposed by Preece in order to avoid the very great difficulty in determining the intensity of a light in a street or space where there were a number of luminous sources, and where the directions of incidence of the different lights vary so greatly.

A carcel standard at the distance of a metre will illumine a surface to the same intensity of illumination as a standard candle at the distance of 12.7 inches. (See *Candle, Foot*.)

Illumined Electrode.—(See *Electrode, Illumined*.)

Imbibition Currents.—(See *Currents, Imbibition*.)

Images, Electric — —A term some-

times applied to the charge produced on a neighboring surface by induction from a known charge.

A positive charge produces, by induction, on a flat metallic surface near it, a negative charge which is distributed with varying density over the surface, but acts electrically as would an equal quantity of negative electricity placed back of the plate at the same distance the positive charge is in front of it. The correspondence of this charge with the image of an object seen in a plane mirror, has led to the term electric image.

Maxwell defines electric image as follows: "An electric image is an electrified point, or system of points, on one side of a surface, which would produce, on the other side of that surface, the same electrical action which the actual electrification of the surface really does produce."

Impedance.—Generally any opposition to current flow.

The sum of the ohmic resistance and the spurious resistance of a circuit measured in ohms.

A quantity which is related to the strength of the impressed electromotive force of a simple periodic or alternating current, in the same manner that resistance is related to the steady electromotive force of a continuous current.

In the case of steady currents, the current strength is equal to the electromotive force divided by the resistance; or,

$$\text{Current strength} = \frac{\text{Electromotive force}}{\text{Resistance.}}$$

In the case of a simple periodic or alternating current, the average current strength is equal to the average impressed electromotive force divided by the impedance; or,

$$\text{Average current strength} = \frac{\text{Average impressed electromotive force}}{\text{Impedance.}}$$

Since impedance, like true resistance of the circuit, can be measured in ohms, it is sometimes called the virtual resistance.

Impedance is a quantity equal to the square root of the sum of the squares of the inductive resistance of the circuit and the ohmic resistance.

In the case of simple periodic or alternating currents, the average current strength is equal to the average impressed electromotive force, divided by the impedance; the maximum current strength

is equal to the maximum impressed electromotive force, divided by the impedance.

The impedance of a circuit can be represented geometrically as follows: Draw a right angled triangle (Fig. 296), the base of which represents the ohmic resistance of the circuit, and the perpendicular, the inductive resistance; then the hypotenuse will represent the impedance.

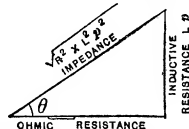

Fig. 296. Geometrical Representation of Impedance.

Since the ohmic resistance equals R , and the inductive resistance equals the inductance L , multiplied by $2\pi n$, in which n , is the frequency, the value of the impedance is equal to

$$\sqrt{R^2 + 4\pi^2 n^2 L^2}.$$

Impedance Coil.—(See *Coil, Impedance*.)

Impedance, Impulsive or Oscillatory — —The impedance which a conductor offers to an impulsive or oscillatory discharge.

The impulsive impedance varies in simple proportion to the frequency of the periodic current. It depends on the form and size of the circuit, but it is independent of its resistance or permeability.

Imponderable.—That which possesses no weight.

A term formerly applied to the luminiferous or universal ether, but now generally abandoned.

It is very questionable whether it is possible for any form of matter to be actually imponderable or to possess no attraction for other matter.

An imponderable fluid, as, for example, the universal ether, as the term is now generally employed, is a fluid whose weight is comparatively small and insignificant, and not a fluid an infinite quantity of which would be entirely devoid of weight.

Impressed Electromotive Force.—(See *Force, Electromotive, Impressed*.)

Impulse, Electro-Magnetic — —An impulse produced in the ether surrounding a conductor by the action of an impulsive discharge, or by a pulsating field.

Impulse, Electromotive — —An impulse producing an impulsive rush of electricity.

The term is employed to distinguish between the ordinary electromotive force which produces a steady current of electricity and an electromotive impulse which produces an impulsive rush of electricity or impulsive discharge.

Impulsion Cell.—(See *Cell, Impulsion*.)

Impulsion Effect.—(See *Effect, Impulsion*.)

Impulsive Impedance.—(See *Impedance, Impulsive or Oscillatory*.)

Incandescence.—To shine or glow by means of heat.

Incandescence.—The shining or glowing of a substance, generally a solid, by reason of a sufficiently high temperature.

Incandescence, Electric — —The shining or glowing of a substance, generally a solid, by means of heat of electric origin.

Electric incandescence of solid substances differs from ordinary incandescence, in the fact that unless the substance is electrically homogeneous throughout, the temperature is not uniform in all parts, but is highest in those portions where the resistance is highest and the radiation smallest.

The deposition of carbon in and on a carbon conductor by the *flashing process* is quite different as performed by electrical incandescence, than it would be if the carbons were heated by ordinary furnace or other heat. (See *Carbons, Flashing Process for*.)

Incandescence, Thermal — —The shining or glowing of a substance, generally a solid, by means of heat other than that of electric origin.

Incandescent.—Shining or glowing with heat.

Incandescent Ball Electric Lamp.—(See *Lamp, Electric, Incandescent Ball*.)

Incandescent Electric Lamp, Life Curve of — —(See *Curve, Life, of Incandescent Lamp*.)

Incandescent Electric Lamp, Life of — —(See *Lamp, Electric, Incandescent, Life of*.)

Incandescent Straight Filament Lamp.—(See *Lamp, Incandescent, Straight Filament*.)

Incandescing.—Glowing or shining by means of heat.

Inclination, Angle of — —The angle which a magnetic needle, free to move in a vertical and horizontal plane, makes with a horizontal line passing through its point of support.

The angle of magnetic dip.

A magnetic needle, supported at its centre of gravity, and capable of moving freely in a vertical as well as in a horizontal plane, does not retain a horizontal position at all parts of the earth's surface.

The angle which marks its deviation from the horizontal position is called the angle of dip or inclination. (See *Dip, Magnetic.*)

Incandescent Electric Lamp. — (See *Lamp, Electric, Incandescent.*)

Inclination Chart.—(See *Chart, Inclination.*)

Inclination Compass.—(See *Compass, Inclination.*)

Inclination, Magnetic — —The angular deviation from a horizontal position of a freely suspended magnetic needle. (See *Dip, Magnetic. Chart, Inclination.*)

Inclination Map.—(See *Map or Chart, Inclination.*)

Inclination of Magnetic Needle.—(See *Needle, Magnetic, Inclination of.*)

Inclinometer.—A name sometimes given to an inclination compass. (See *Compass, Inclination.*)

Incomplete Circuit.—(See *Circuit, Incomplete.*)

Increased Electric Irritability.—(See *Irritability, Electric, Increased.*)

Increment Key.—(See *Key, Increment.*)

Increment Key of a Quadruplex Telegraphic System.—(See *Key, Increment, of Quadruplex Telegraphic System.*)

India Rubber.—A resinous substance obtained from the milky juices of several tropical trees.

India rubber or caoutchouc is obtained from the *Siphonia elastica* of South America.

India rubber is quite elastic and possesses high powers of electric insulation. When vulcanized or combined with sulphur, it still retains its powers of electric insulation in a high degree. In this state it is highly electrified by friction. (See *Caoutchouc.*)

Indicating Bell.—(See *Bell, Indicating.*)

Indicator, Automatic — —Any automatic device for electrically indicating the number of times a circuit has been opened or closed, and thus the number of times a given operation has occurred which has caused the opening or closing of such circuit.

An annunciator with an automatic drop is sometimes called an automatic indicator. (See *Annunciator, Electro-Magnetic. Annunciator Drop, Automatic.*)

Indicator, Electric — —A name applied to various devices, generally operated by the deflection of a magnetic needle, or the ringing of a bell, or both, for indicating, at some distant point, the condition of an electric circuit, the strength of current that is passing through it, the height of water or other liquid, the pressure on a boiler, the temperature, the speed of an engine or line of shafting, the working of a machine or other similar events or occurrences.

A term sometimes used in place of annunciator. (See *Annunciator, Electro-Magnetic.*)

Indicators are of various forms. They are generally electro-magnetic in character. They are automatic in action.

Indicator, Electric Circuit — —A device, generally in the form of a vertical galvanometer, employed to indicate the presence and direction of a current in a circuit, and often to roughly measure its strength. (See *Galvanometer, Vertical.*)

Indicator, Electric, for Steamships — —An electric indicator operated by circuits connected with the throttle valve and reversing gear of the steam engine.

The signal "stop," for example, sent by the navigating officer to the engineer, causes him to close the throttle. This act places the indicator needle at "stop," and thus informs the officer that his signal has been obeyed. In the same

manner, the opening of the throttle sets the indicator needle to "ahead," etc.

Indicator, Electric Throwback — — An annunciator with a drop that is electrically replaced. (See *Annunciator, Electro-Magnetic.*)

Indicator, Lamp — — An apparatus used in the central station of a system of incandescent lamp distribution to indicate the presence of the proper voltage or potential difference on the mains.

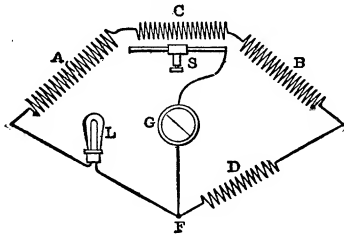

Fig. 297. Edison-Howell Lamp Indicator.

The lamp indicator of Edison and Howell is shown in Fig. 297. It consists essentially of a Wheatstone bridge with the resistances arranged as shown. A galvanometer at G, serves, by the movements of its magnetic needle, to act as an indicator. This needle remains at zero, when the potential difference is the exact voltage required on the circuit with which the indicator is connected. The incandescent lamp at L, being one of the resistances, and being constantly traversed by the current, will have a fixed resistance for the temperature at which it is designed to run. The other resistances are so proportioned as to insure the needle at G, remaining at zero. If, however, the potential varies, the temperature of the lamp L, varies, and, being carbon, its resistance also varies, a rise of temperature corresponding to a fall of lamp resistance, which destroys the balance of the bridge and deflects the galvanometer needle. The attendant then regulates the potential to bring the needle back to zero.

Indicator, Mechanical Throwback — — An annunciator with a mechanical drop. (See *Annunciator, Electro-Magnetic. Annunciator, Drop. Annunciator, Gravity.*)

Indicator, Pendulum — — An annunciator, the indicating arm of which is operated

by means of a pendulum. (See *Annunciator, Pendulum.*)

Indicator, Potential — — An apparatus for indicating the potential difference between any points of a circuit.

A voltmeter is a potential indicator. It is, however, more than an indicator, since it gives the value of the potential difference in volts. (See *Voltmeter.*) A lamp indicator is a potential indicator. (See *Indicator, Lamp.*)

Indicator, Semaphore — — An annunciator in which a gravity drop or shutter is caused to fall by the action of the electric current, thus exposing a number of other signals back of the drop or shutter.

Indicator, Speed — — A name sometimes applied to a tachometer. (See *Tachometer.*)

A form of speed indicator is shown in Fig. 298. The endless screw drives the wheel when the triangular point is held firmly against the centre of the revolving shaft or pulley.

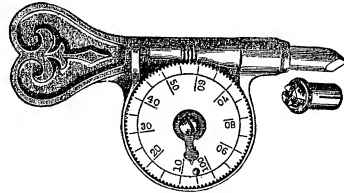

Fig. 298. Speed Indicator.

Indicator, Voltaic Battery — — A device for indicating the condition of a voltaic battery.

Indifferent Point.—(See *Point, Indifferent.*)

Indirect Excitation.—(See *Excitation, Indirect.*)

Induced Atomic Currents.—(See *Currents, Induced, Atomic or Molecular.*)

Induced Current.—(See *Current, Induced.*)

Induced Direct Current.—(See *Current, Direct, Induced.*)

Induced Electrostatic Charge.—(See *Charge, Induced Electrostatic.*)

Induced Molecular Currents.—(See *Currents, Induced Molecular.*)

Induced Reverse Currents.—(See *Current, Reverse, Induced.*)

Inductance — —The induction of a circuit on itself, or on other circuits.

Self-induction.

A term now generally employed instead of self-induction.

That property in virtue of which a finite electromotive force, acting on a circuit, does not immediately generate the full current due to its resistance, and when the electromotive force is withdrawn, time is required for the current strength to fall to zero.—(*Fleming.*)

A quality by virtue of which the passage of an electric current is necessarily accompanied by the absorption of electric energy in the formation of a magnetic field.

The inductance of a circuit depends:

- (1.) On the form or shape of the circuit.
- (2.) On the magnetic permeability of the space surrounding the circuit.
- (3.) On the magnetic permeability of the circuit itself.

For the variations of current strength in electric circuits, inductance is not unlike mass, or moment of inertia, as regards variations of velocity. Time is required to produce velocity in a heavy body by the action of any force; so also time is required to produce a current by the action of an electromotive force.

The electro-magnetic energy present in any given current is equal to the square of the current multiplied by the inductance. Since one of these factors (the current strength) represents the force, the other, the inductance, must have the dimension of a distance or length. Inductance, therefore, is measurable in units of length. If the circuits are formed of magnetizable materials, the inductance of a circuit is the ratio between the total inductance taking place through the circuit to the current producing it.

If the circuit is formed entirely of non-magnetic material, surrounded entirely by materials of constant magnetic permeability (such as air, insulators and diamagnetic materials generally), the inductance is a constant quantity and depends only on the form or shape of the circuit. In this case, the total inductance through the circuit is proportional to the magnetizing force, and the magnetic resistance, or the magnetic conductance of the magnetic circuit, is equal to the total induc-

tion through the circuit, divided by the magnetizing force.

In cases where the magnetic circuit is partly or wholly of paramagnetic substances, where the induction bears no constant ratio to the magnetizing force, and where the induction takes place partly or wholly in media of variable permeability, the co-efficient of self-induction, or the inductance, must be defined in three ways:

(1.) As the ratio between the counter electromotive force in any circuit and the time rate of variation of the current producing it.

(2.) As the ratio between the total induction through the circuit and the current producing it.

(3.) As the energy associated with the circuit in the form of magnetic field, due to unit current in that circuit, or as the co-efficient by which half the square of the current must be multiplied to obtain the electro-kinetic energy of the circuit at that instant.—(*Fleming.*)

A flat sheet or strip of metal possesses less inductance than a round conductor of equal cross-section.

This may be explained by conceiving that a flat conductor presents a greater absorption surface to the dielectric.

Therefore, the perfect form for a conductor transmitting rapidly alternating currents is that of a flat sheet or strip of copper, or preferably a copper tube.

The experiments of Hughes show that the inductance of a conductor may be regarded as an effect due to the time required for the rapidly periodic current to penetrate the conductor, and that the decrease in the inductance, produced by forming the conductor of a strip or bar, is due to the decreased distance the current has to pass to the inner parts.

Inductance, Absolute Unit of — —A unit of length equal to one centimetre.

A length equal to an earth quadrant or 10^9 centimetres is called the practical unit of inductance. The practical unit of inductance was formerly called a secohm or quadrant. It is now generally called a henry. (See *Henry, A.*)

Inductance Bridge.—(See *Bridge, Inductance.*)

Inductance, Co-efficient of — —A constant quantity, such that when multiplied by the current strength passing in any coil or circuit, will represent numerically the induction through the coil or circuit due to that current.

A term sometimes used for co-efficient of self-induction. (See *Induction, Co-efficient of.*)

Inductance, Constant — —The inductance which occurs in circuits formed wholly of non-magnetic materials, immersed in or surrounded by media of constant magnetic permeability or magnetic conductance for lines of magnetic force. (See *Permeability, Magnetic.*)

When the lines of magnetic force pass through such materials as ordinary insulators, or diamagnetic materials, such as copper, the inductance is constant, provided the geometric form of the circuit remains the same.

Inductance, Formal, of Circuit — — That part of the counter electromotive force of a circuit which depends on the form of the circuit.

Inductance, or Self-Induction, Practical Unit of — —A length equal to the earth quadrant or 10^9 centimetres.

The absolute unit of inductance is equal to 1 centimetre.

Inductance, Oscillatory, Electric — — Inductance produced by electric oscillations.

Inductance, Unit of — —A term now generally used for unit of self-induction.

The value of the inductance may be given either in absolute or in practical units of inductance. The absolute unit of inductance is equal to a length of one centimetre. The practical unit of inductance is equal to 1,000,000,000 centimetres or 10^9 centimetres.

The practical unit of inductance was formerly called a seohm. The term henry is generally used for this unit. (See *Henry, A.*)

Inductance, Variable — —The inductance which occurs in circuits formed partly or wholly of substances like iron or other paramagnetic substances, the magnetic permeability of which varies with the intensity of the magnetic induction, and where the lines of force have their circuit partly or wholly in such material of variable magnetic permeability.

Induction.—An influence exerted by a

charged body or by a magnetic field on neighboring bodies without apparent communication.

A medium is necessary to connect the body producing the induction and that in which the induction is produced. (See *Induction, Electrostatic. Induction, Magnetic. Induction, Electro-Dynamic.*)

Induction, Apparent Co-efficient of — —A term sometimes used for co-efficient of apparent magnetic induction. (See *Induction, Magnetic, Apparent Co-efficient of.*)

It is called the apparent co-efficient of induction because its value is different from what it would be if the eddy currents were entirely suppressed. The eddy currents increase the resistance of the primary and decrease its inductance.

Induction-Balance, Hughes' — —(See *Balance, Induction, Hughes'.*)

Induction, Balance of, in Cable — — The removal of induction in a cable by neutralization by the presence of equal and opposite effects.

A balance is obtained of the inductive effects of the neighboring conductors, whether in the bunched cable or outside of it.

Induction-Bridge.—(See *Bridge, Inductance.*)

Induction, Co-efficient of — —A term sometimes used for co-efficient of magnetic induction. (See *Induction, Magnetic, Co-efficient of.*)

Induction Coil.—(See *Coil, Induction.*)

Induction Coil, Inverted — —(See *Coil, Induction, Inverted. Transformer.*)

Induction, Current — —A term sometimes used for voltaic induction. (See *Induction, Voltaic. Induction, Electro-Dynamic.*)

Induction, Dissymmetrical, of Armature — —An induction produced by the passage of a different number of lines of magnetic force through adjoining halves of the armature.

Induction, Electro-Dynamic — —Electromotive forces set up by induction in conductors which are either actually or practically moved so as to cut the lines of magnetic force.

These electromotive forces, when permitted to act through a circuit, produce an electric current.

Electro-dynamic induction may be produced in any circuit in two ways:

(1.) By causing expanding or contracting lines of magnetic force to pass through that circuit.

(2.) By causing the circuit or conductor to pass through the lines of magnetic force.

In all cases the lines of force are made to pass through the conductor or wire.

There are four cases of electro-magnetic induction:

(1.) That in which expanding or contracting lines of magnetic force, produced by rapidly varying the current in any circuit, are caused to pass through or cut that circuit and consequently to produce differences of potential therein.

(2.) That in which expanding or contracting lines of magnetic force produced by any circuit by the rapidly varying strength of the electric current passing through that circuit, are caused to pass through another neighboring circuit and thus produce differences of potential therein.

(3.) That produced by moving a conductor through a magnetic field so as to cut its lines of magnetic force. In this way the strength of the magnetic field may remain practically constant, but this strength as regards the field of the fixed conductor is varying, as the magnet producing such a field is moved toward or from such circuit, and in this way differences of potential are produced in the circuit.

(4.) That produced by moving an inducing field past a fixed conductor. This may be accomplished by moving an electro-magnet, an electric circuit, or a permanent magnet past the conductor in which the difference of potential is to be induced.

There are therefore four distinct varieties of electro-dynamic induction:

(1.) Self-induction or inductance. (See *Inductance*.)

(2.) Mutual induction, or, as it is sometimes called, voltaic current induction. (See *Induction, Mutual*.)

(3.) Electro-magnetic induction, or, as it is sometimes called, dynamo-electric induction.

(4.) Magneto-electric induction.

If the terminals of a voltaic cell be connected with the ends of a comparatively long coil of insulated wire, no appreciable spark will be observed on closing the cell, because the current induced by self-induction is in the opposite direction to the

current of the cell and weakens it. On breaking contact, however, a spark is readily observed. This is due to the induced current on breaking, which, flowing in the same direction as the current of the cell, strengthens it.

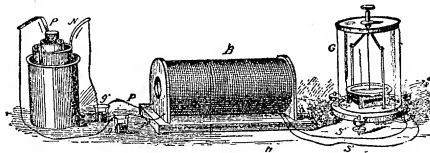

Fig. 299. Mutual Induction

The coil B, Fig. 299, consists of two parallel coils of insulated wire, the terminals of one of which, called the *primary coil*, are connected with the battery cell P N, and those of the other, called the *secondary coil*, with the galvanometer G.

Under these circumstances it is found:

(1.) That at the moment of closing the circuit through the primary coil, a momentary current is produced in the secondary coil in a *direction opposite to that of the current through the primary*, as is shown by the direction of the deflection of the needle of the galvanometer.

(2.) At the moment of breaking the circuit through the primary coil, an induced current is produced in the secondary coil in the *same direction as that flowing through the primary coil*.

(3.) These induced currents are momentary, and continue in the secondary only while the intensity of the current in the primary is varying, *i. e.*, while variations are occurring in the strength of the magnetic field in which the secondary coil is placed, therefore while the expanding or contracting lines of force are passing through the secondary coil.

If, for instance, when the current is established in the primary coil, and no current exists in the

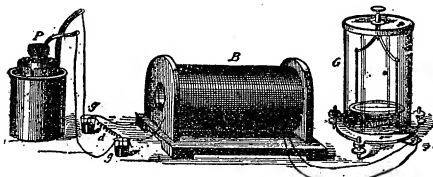

Fig. 300. Mutual Induction.

secondary, the intensity of the current in the primary be varied by establishing a *shunt circuit* across the battery terminals, as by placing a short wire d, Fig. 300, in the mercury cups g, g, thus

decreasing the intensity of the current in the primary, an induced current will be set up in the secondary circuit in the same direction as the primary current.

From all of these phenomena, we see that any *increase* of current in a conductor produces in a neighboring conductor an *induced inverse* current, or one in the *opposite direction to the inducing current*, while a *decrease* of such current produces a *direct induced current*, or one in the *same direction as the inducing current*.

If the induction coil be made, as in Fig. 301, with its primary coil movable into and out of the secondary coil, then the following phenomena will occur:

(1.) When the primary coil is moved toward the secondary coil an *inverse* current is induced in the secondary; and,

(2.) When the primary coil is moved away from the secondary coil a *direct* current is induced in the secondary.

The movements of permanent magnets towards or from a coil will also produce an induced current.

If, for example, the apparatus be arranged as in Fig. 302, then:

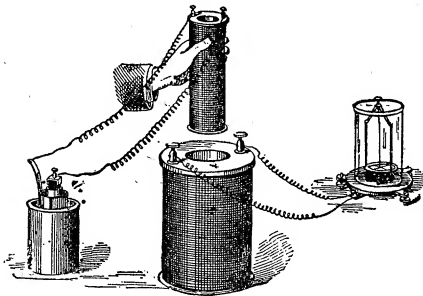

Fig. 301. Electro-Dynamic Induction.

(1.) A motion of the magnet towards the coil produces an induced current in the coil in one direction, and

(2.) Its motion away from the magnet produces an induced current in the coil in the opposite direction.

The directions of these induced currents are respectively *inverse* and *direct* as compared with the direction of the ampèrian currents which are assumed to produce the magnetic poles of permanent magnets, or of the currents that actually produce electro-magnets. (See *Magnetism, Ampère's Theory of*.)

These facts may be expressed by the following laws :

(1.) Any *increase* in the number of lines of force

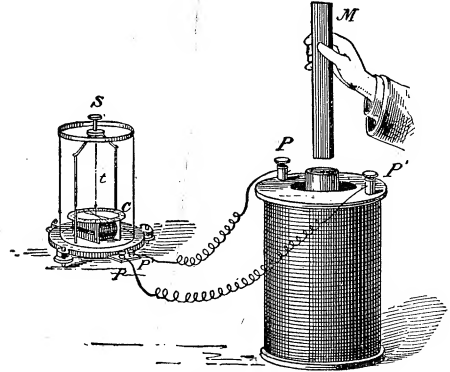

Fig. 302. Magneto-Electric Induction.

which pass through a circuit produces an inverse current in that circuit, while any *decrease* in the number of such lines of force which pass through any circuit produces a *direct* current in that circuit.

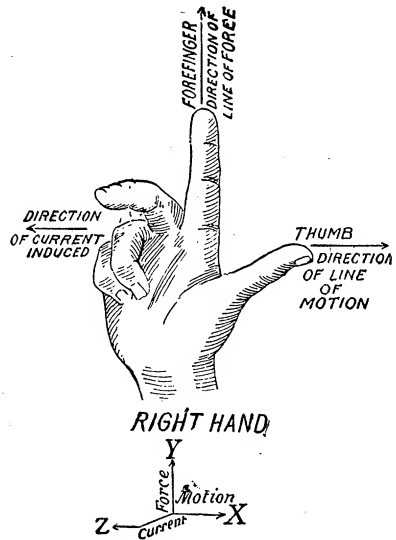

Fig. 303. Fleming's Rule.

(2.) The intensity of the induced current, or, more correctly, the *difference of potential* produced, is proportional to the rate of *increase* or *decrease* of the lines of force passing through the circuit.

A conductor, therefore, when moved through

a magnetic field so as to cut the lines of magnetic force, will have a difference of potential generated, and if its circuit is closed so that the difference of potential can neutralize itself, it will have a current produced in it by induction.

A simple but effective manner of remembering the direction of such currents is that proposed by Fleming.

If the hand be held with the fingers extended, as in Fig. 303, and the direction of the *forefinger* represent the positive direction of the lines of force, *i. e.*, those coming out of the N. pole of a magnet, then, if a wire or other conductor be moved in the direction in which the *thumb* points, so as to cut these lines of force at right angles, that is, if the conductor have its length moved directly across these lines, it will have an induced current developed in it in the direction in which the *middle finger* points. (See *Force, Lines of, Direction of.*)

Or, the same thing can, perhaps, be even more readily remembered by cutting a piece of paper in the shape shown in Fig. 304, marking it as shown, and then bending the arm P, upward at the dotted line, so as to form three axes at right angles to one another.

As has been already remarked, a *difference of potential*, and not a current, is produced by moving a conductor through a magnetic field so as to cut its lines of force.

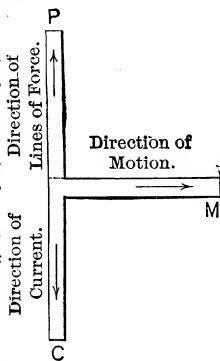

Fig. 304. Fleming's Rule.

It can be shown that in order to generate a difference of potential of *one volt*, 100,000,000 C. G. S. lines of force must be cut per second.

In electro-dynamic induction, the induced current is produced by the energy absorbed in moving the conductor through the magnetic field. Lenz has shown that in all cases of electro-dynamic induction, produced by the movement either of the circuit or of the magnet, the current induced in the circuit is in such a direction as to produce a magnet pole which would tend to oppose the motion.

Induction, Electro-Magnetic — — A variety of electro-dynamic induction in which electric currents are produced by the motion

of electro-magnets or electro-magnetic solenoids. (See *Induction, Electro-Dynamic.*)

Induction, Electrostatic — — The production of an electric charge in a conductor brought into an electrostatic field.

If the insulated conductor A B, Fig. 305, be brought into the positive electrostatic field of the insulated conductor C, then,

(1.) A charge will be produced on A and B, as will be indicated by the divergence of the pith balls.

(2.) This charge is negative at the end A, nearest C, and positive at the end B, furthest from C, as can be shown by an *electroscope*. (See *Electroscope.*)

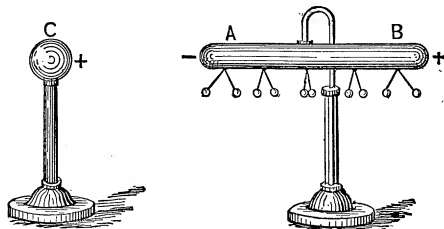

Fig. 305. Electrostatic Induction.

(3.) The charges at A and B, are equal to each other; for, if the conductor A B, be removed from the field of C, without touching it, the opposite charges completely neutralize each other.

(4.) If, however, the conductor A B, be touched at any place by a conductor connected with the earth, it will lose its positive charge, and will remain negatively charged when removed from the field of C. It is in this manner that an *electrophorus* is charged. (See *Electrophorus.*)

(5.) The amount of the charges produced in the conductor, A B, can never be greater than that in the inducing body C. That is to say, the

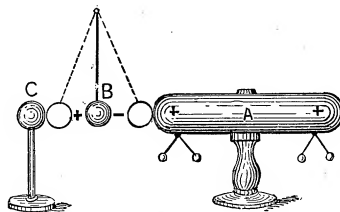

Fig. 306. Induction Precedes Attraction.

negative electricity at A, may be sufficient in amount to neutralize the positive charge on C, if allowed to do so. In point of fact the charge in-

duced is less in amount than the inducing charge, according to the distance between C and A, and the nature and condition of the medium which separates them.

The attractions of light bodies by charged surfaces are due to the opposite charge produced on those parts of the light bodies that are nearest the charged body.

The pith ball B, Fig. 306, suspended by a silk thread between an insulated positively charged conductor A, and the uninsulated conductor C, will receive by induction a negative charge on the side nearest A, and a positive charge on the side nearest C. It is therefore attracted to A, where, receiving a positive charge, it is repelled to C, where it is discharged and again assumes a vertical position. Induction again occurs, and consequent attraction and repulsion. These movements follow one another so long as a sufficient charge remains in A.

Induction, Faradic, Apparatus — —
(See *Apparatus, Faradic Induction.*)

Induction-Finder.—(See *Finder, Induction.*)

Induction, Lateral — —An induction observed between closely approached portions of a circuit through which an impulsive discharge, such as the disruptive discharge of a Leyden jar, is passed as a long spark, thereby making the resistance of the circuit high.

A long copper wire, bent in the form of a rectangle, has its free ends near their extremities bent so as to approach within half an inch of each other. One of the ends of the wire is provided with a metallic ball and the other end connected with the earth. If, now, a Leyden jar charge is passed through the wire by connecting the outer coating with the end of the earth-connected wire and holding the inside coating near the knob, a spark will pass through the half inch of space between the approached portions of the circuit.

This discharge is due to what was formerly called lateral induction. The discharge of a Leyden jar is an oscillatory discharge, and it passes through the intervening air space instead of through the conductor because the resistance of the latter to the rapid alternations produces a counter electromotive force which acts as a resistance whose value is greater than that of the air space itself. (See *Path, Alternative.*)

Induction, Magnetic — —The production of magnetism in a magnetizable substance by bringing it into a magnetic field.

Suppose a small portion of a magnetizable body is placed in a magnetic field produced in a gap separating two closely approximated poles. To simplify matters, suppose this small portion to be a free unit pole. It will be acted on by two forces:

(1.) The force due to the magnetic field.

(2.) The force due to the free magnetism, which appears at the surface of the gap or cut.

The force on the unit pole is compounded of these two separate forces, and is called the *magnetic induction* of the space. Magnetic induction is, therefore, strictly speaking, a quantity.

The direction of magnetic force and the magnetic induction are the same in an air space outside a magnet. Within a bar of iron or other paramagnetic material, under induction in a magnetic field, the magnetic force at any point is due not only to the external or original field, but also to the field produced by the polarity induced, which acts opposed to the magnetic force at points. Magnetic force and magnetic induction are identical only where there is no magnetism.—(*Fleming.*)

When a magnetizable body is brought into a magnetic field the following phenomena occur, viz.:

(1.) The lines of magnetic force pass through the body and are condensed upon it. (See *Field, Magnetic. Paramagnetic.*)

(2.) If the body is free to move around an axis, but is not free to move bodily towards the magnet pole, it will come to rest with its greatest extent or length in the direction of the lines of force; *i. e.*, in the direction in which it will offer the least resistance to the lines of force that thread through it.

(3.) The body will therefore become a magnet, its south pole being situated where the lines of force enter it and its north pole where they pass out from it. Since the lines of magnetic force are assumed to come out of the north pole of a magnet and to enter its south pole, if a magnetizable substance is brought near a north pole, the lines of force from that north pole will enter it at those parts nearest such north pole, thereby rendering such points south, and will pass out of its further end, which will thereby become north.

(4.) The intensity of the induced magnetism

will depend on the number of lines of force that pass through it.

(5.) The direction of the *axis of magnetization* will depend on the directions in which the lines of force thread through the body. (See *Axis, Magnetic.*)

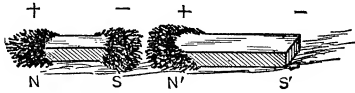

Fig. 307. *Magnetic Induction.*

If a bar of iron, $N' S'$, Fig. 307, be brought near the magnetized bar, $N S$, poles will be produced in it by induction, as may be shown by throwing iron filings on it.

The nearer the body to be magnetized is brought to the magnetizing pole the greater will be the number of lines of force that thread through it. Consequently, the intensity of the induced magnetism will be greater; this will be greatest when the bodies actually touch each other.

The production of magnetism, therefore, by contact or touch is only a special case of the production of magnetization by induction.

The attraction of a magnetizable body by a magnet pole is caused by the mutual attraction which exists between the pole produced by induction and the pole producing the induction. This, it will be seen, is similar to the attraction caused by an electric charge.

The following terms are given by Fleming as employed in the same sense as magnetic induction of an area:

- (1.) The number of unit tubes of induction passing through the area.
- (2.) The number of lines of force (induction) passing through the area.—(*Faraday.*)
- (3.) The total magnetic induction through the area.—(*Maxwell.*)
- (4.) The flux or flow of magnetic induction through an area.—(*Mascart & Foubert.*)
- (5.) The surface-integral of magnetic induction over an area.—(*Fleming.*)

Induction, Magnetic, Apparent Co-efficient of — —The co-efficient of induction as influenced by the presence of eddy currents.

This is called the co-efficient of apparent induction, because its value is not the same as it would be if the eddy currents were entirely suppressed.

The value of the co-efficient of apparent induction depends on the amount of the retardation of the magnetism; or, what is the same thing, on the strength of the eddy currents.

Induction, Magnetic, Co-efficient of — —A term sometimes used instead of magnetic permeability. (See *Permeability, Magnetic.*)

The ratio existing between the number of lines of magnetic induction that pass through any area of cross-section of a magnetic circuit and the magnetizing force producing such induction.

If B , equals the magnetic induction, or the number of lines of force that pass through any area of cross-section, and H , equals the magnetizing force, and μ , equals the permeability, or the co-efficient of magnetic induction; then,

$$\mu = \frac{B}{H}$$

Induction, Magnetic, Dynamic — —The induction which takes place in the field of a magnet whose field is moving as regards the body in which induction is occurring.

This movement of the field may be attained,

- (1.) By the movement of the magnet.
- (2.) By the movement of the body in which induction is taking place.
- (3.) By the expansion or contraction of the lines of magnetic force produced by variations of the strength of the magnetic field; or, in other words, by the movement of the field. (See *Induction, Electro-Dynamic.*)

Induction, Magnetic, Flux or Flow of — —A term employed in the same sense as the magnetic induction which takes place through any given area.

The flux or flow of magnetic induction is equal to the magnitude of the area multiplied by the normal induction which takes place in one unit of that area.

Induction, Magnetic, Lines of — —Lines which show not only the direction in which magnetic induction takes place, but also the magnitude of the induction.

A line of induction may be regarded as a line along which induction takes place, or as the axis of a tube of induction.

This term is often loosely used for lines of force.

Induction, Magnetic, Static — —The

induction which takes place in the field of a magnet whose field is stationary as regards the body in which induction is occurring.

The term static magnetic induction is used in contradistinction to dynamic magnetic induction which occurs in a moving field. (See *Induction, Electro-Dynamic.*)

Induction, Magnetic, Surface-Integral of — — A term employed in the same sense as the magnetic induction which takes place over a given area.

Induction, Magneto-Electric — — A variety of electro-dynamic induction in which electric currents are produced by the motion of permanent magnets, or of conductors past permanent magnets. (See *Induction, Electro-Dynamic.*)

Induction, Mutual — — Induction produced by two neighboring circuits on each other by the mutual interaction of their magnetic fields. (See *Induction, Electro-Dynamic. Currents, Extra.*)

Induction produced in neighboring charged conductors by the mutual interaction of their electrostatic fields. (See *Field, Electrostatic.*)

The mutual induction of two conductors or circuits, is equal to the ratio of the induction which takes place through one of the circuits, to the strength of current in the other circuit, which is producing the induction

Induction, Mutual, Co-efficient of — — The quantity which represents the number of lines of force which are common to or linked in with two circuits, which are producing mutual induction on each other.

The maximum value the co-efficient of mutual induction can have, is equal to the square root of the product of the inductance of the two circuits, or $\sqrt{L \times N}$, in which L and N, are the constant co-efficients of self-induction of the two circuits.

Induction, Mutual, Loops of — — Loops or lines of induction produced in any circuit by variations in the intensity of the current flowing in a neighboring circuit.

The lines of induction produced by a circuit, in which a current of electricity is flowing, are closed loops or circles surrounding the circuit once or more. The wire or circuit is formed by

coiling a conductor a number of times in a circular coil, and this circular coil is placed near another coil in which a varying current is flowing.

As the lines of induction grow or increase, they cut the circular coil, forming lines of induction in the shape of loops, a number of which pass around it. They are called loops of mutual induction.

Induction, Open-Circuit — — The induction produced in an open circuit by means of electric pulses in neighboring circuits.

The researches of Hertz have shown that when an impulsive discharge, or an oscillatory discharge, occurs, an induction occurs even in open circuited conductors. He shows that these inductive effects are due to electro-magnetic waves or oscillations set up in the surrounding ether, which are propagated through free ether with the velocity of light. When these electro-magnetic waves or radiations impinge on any circuit, if its dimensions be such that sympathetic vibrations can be excited therein, such vibrations are set up and cause similar phenomena to those of the exciting cause, viz., oscillatory discharges or electro-magnetic vibrations. Hertz calls these sympathetic circuits, resonators, from their resemblance to acoustic resonators. (See *Resonators, Electric.*)

Induction, Oscillatory — — A name sometimes applied to open-circuit induction. (See *Induction, Open-Circuit.*)

Induction, Reflection of — — A term proposed by Fleming to express an action which resembles a reflection of inductive power.

The coils A and B, Fig. 308, are arranged as

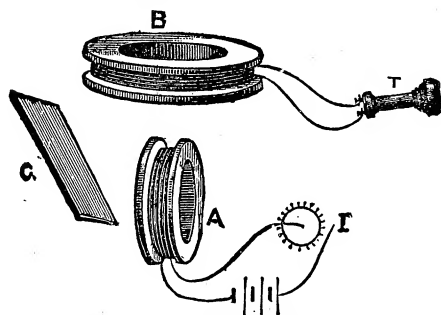

Fig. 308. Reflection of Induction.

shown, so as to act as the primary and secondary respectively of an induction coil, and are placed

conjugate or perpendicular to each other. (See *Coils, Conjugate*.) Therefore, no sounds are heard in the telephone T, when the current is rapidly reversed. If, however, a plate of copper, C, is placed in the position shown, then sounds are heard in the telephone. The action here resembles a reflection of the inductive action from A to B, by means of the plate C. The explanation is, of course, simple. Though A, can exert no action on B, because the two coils are conjugate to each other, yet A, can produce secondary currents in C; and these reacting on B, produce tertiary currents in C, and, therefore, sounds in the telephone.

Induction, Self — — Induction produced in a circuit at the moment of starting or stopping the currents therein by the induction of the current on itself. (See *Currents, Extra*.)

A coil having unit self-induction, is sometimes said to have one tube of induction, or line of force added to its field for each increase of one unit of current.

Induction, Self, Absolute Unit of — — A term sometimes employed for absolute unit of inductance. (See *Inductance, Absolute Unit of*.)

Induction, Self, Ayrton & Perry's Standard of — — A standard for the comparison of values of self-induction.

The standard of self-induction of Ayrton & Perry consists of three bobbins of wire, two fixed and one movable. The movable bobbin is so arranged as to be capable of motion through 180 degrees within the fixed bobbins. The coils are wound on the surface of the zone of a sphere.

This apparatus permits of the ready comparison of the self-induction in different circuits, or in the same circuit under different conditions.

Induction, Self, Co-efficient of — — The number of lines of force the current would induce or enclose in itself when the current flowing through it is equal to one absolute unit.

A term sometimes employed in the sense of inductance of a circuit.

The co-efficient of self-induction is defined by Fleming as follows: "In the case of circuits conveying electric currents, which are wholly made of non-magnetic material, and wholly immersed

in a medium of constant magnetic permeability, the total induction through the circuit per unit of current flowing in that circuit, when removed from the neighborhood of all other magnets and circuits, is called the co-efficient of self-induction; otherwise the ratio of the numerical values of the electro-magnetic momentum of such circuit, and the current flowing in it, when totally removed from all other currents and magnets, is the numerical value of the inductance of the circuit."

Since the magnetic lines due to a current in a circuit thread through the convolutions of the circuit itself, any variation in the current induces a difference of potential in the circuit itself, since the lines of force produced by the current in the circuit pass through or cut the circuit.

The ratio between this self-induced electromotive force, and the rate of change in the current which causes it, is called the co-efficient of self-induction.—(S. P. Thompson.)

For a given coil the co-efficient of self-induction is, according to S. P. Thompson:

(1.) Proportional to the square of the number of convolutions.

(2.) Is increased by the use of an iron core.

(3.) If the magnetic permeability is assumed as constant, the co-efficient of self-induction is numerically equal to the product of the number of lines of magnetic force due to the current, and the number of times they are enclosed by the circuit.

Induction, Self, Magnetic — — A retardation in the appearance of magnetization, after the application of the magnetizing force, due to the influence of the magnetic lag.

Magnetic retardation.

This retardation in the magnetization has received the name of magnetic self-induction or retardation because it corresponds to the retardation in the starting or stopping of a current, in a conducting circuit, due to the self-induction of the current.

Induction, Self, Unit of — — The unit of inductance. (See *Inductance, Unit of*.)

The unit of self-induction is now generally called the unit of inductance.

Induction, Symmetrical, of Armature — — An induction produced by the simultaneous passage of the same number of lines of magnetic force through adjoining halves of the armature.

Induction Telegraphy, Current Induction System of — — (See *Telegraphy, Induction, Current Induction System of.*)

Induction Telegraphy, Static Induction System of — — (See *Telegraphy, Induction, Static Induction System of.*)

Induction Top.—(See *Top, Induction.*)

Induction, Total Magnetic — — The total magnetic induction of any space is the number of lines of magnetic induction which pass through that space, where the magnetizable material is placed, together with the lines added by the magnetization of the magnetic material.

Induction, Tubes of — — A portion of a magnetic field containing a number of closely contiguous lines of induction terminated by equipotential surfaces, or surfaces perpendicular to the lines of induction.

Tubes of induction possess the following characteristics :

(1.) The product of a normal cross-section of a tube and the mean magnetic induction which takes place over that section is the same for all cross-sections of the tube. In other words, the flux or flow of induction is constant throughout the entire length of the tube.

(2.) The normal cross-section of any equipotential surface at any point of a tube of induction is inversely proportional to the magnetic induction at that point.

(3.) All tubes of induction form endless tubes. This is necessary, since all lines of induction form closed circuits.

(4.) All tubes of induction may be expressed by a single line of induction, which, in the case of a uniform field, occupies the centre of the tube, (See *Force, Tubes of.*)

Induction, Voltaic — — A variety of electro-dynamic induction produced by circuits on themselves or on neighboring circuits.

Mutual induction. (See *Induction, Electro-Dynamic.*)

This kind of induction is usually called current induction.

Induction, Unipolar — — A term sometimes applied to the induction that occurs when a conductor is so moved through a

magnetic field as to continuously cut its lines of force.

If the conducting wire, A B C, Fig. 309, be ro-

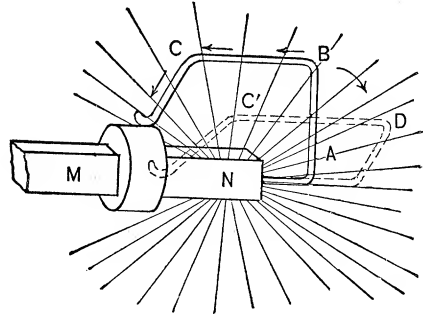

Fig. 309. Unipolar Induction.

tated (in a direction toward the observer) around the pole N, of a magnet, it will continuously cut its lines of magnetic force in practically the same direction, and will therefore produce a difference of potential that will result in a continuous current in the direction of the arrows. The end A, is supported in a recess in N, while the end near C, slides on a projection on the middle of the magnet.

Unipolar induction occurs in the case of Sturgeon's wheel, in which a metallic disc mounted on an axis is rotated between the poles of a magnet so as to cut the lines of magnetic force. In this case a difference of potential is generated which will produce a current that flows from the axis to the periphery, provided contact points are placed on the axis of rotation and the periphery of the disc connecting these parts of the disc in a closed circuit.

Unipolar dynamos operate by the continuous cutting of lines of magnetic force.

Strictly speaking, there is no such thing as a unipolar dynamo or unipolar induction, since a single magnetic pole cannot exist by itself. Continuous cutting of lines of magnetic force, however, can exist, and produces, unlike the ordinary bipolar induction, a continuous current without the use of a commutator.

Inductionless Resistance. — (See *Resistance, Inductionless.*)

Inductive Capacity, Specific — — (See *Capacity, Specific Inductive.*)

Inductive Circuit.—(See *Circuit, Inductive.*)

Inductive Electromotive Force.—(See *Force, Electromotive, Inductive.*)

Inductive Retardation.—(See *Retardation, Inductive.*)

Inductive Resistance.—(See *Resistance, Inductive.*)

Inductivity, Specific Magnetic — — A term sometimes employed for specific magnetic conductivity. (See *Conductivity, Specific Magnetic.*)

Inductometer, Differential — — An apparatus for measuring, by means of a galvanometer, the momentary currents produced by the discharge of a cable.

Currents produced by the discharge of a cable are of so short a duration that they do not produce much more than a momentary effect on a galvanometer needle.

The inductive charge in a cable, or the quantity of electricity produced in it by induction, is:

(1.) Directly as the electromotive force of the charging battery;

(2.) Inversely as the square root of the thickness of the coating of gutta-percha or other insulating material between the conducting wires and the metallic sheathing;

(3.) Directly as the square root of the diameter of the copper wire of the conductor; and

(4.) Dependent on the specific inductive capacity of the insulating material employed in the cable.

In order to cause the cable discharge to more thoroughly affect the galvanometer needle, Mr. Latimer Clark employed a differential instrument with a large battery and three reversing keys, by means of which he gave a rapid succession of charges to the cable. He called the instrument a *Differential Inductometer*.

Inductophone.—A device, suggested by Mr. Willoughby Smith, for obtaining electric communication between moving trains and fixed stations by means of the currents developed by induction in a spiral of wire fixed on the moving engine, by its motion past spirals on the line, into which intermittent currents are passed.

The spiral on the engine is placed in the circuit of a telephone. (See *Telegraph, Inductive.*)

Inductor Dynamo.—(See *Dynamo, Inductor.*)

Inductorium.—A name sometimes applied to a Ruhmkorff induction coil. (See *Coil, Induction.*)

Inequality, Annual, of Earth's Magnetic Variation or Inclination — — Annual variations in the value of the magnetic variation or inclination at any place. (See *Variation, Magnetic. Inclination, Magnetic.*)

Inequality, Annual, of Earth's Magnetism — — Variations in the value of the earth's magnetism during the earth's revolution depending on the position of the sun.

Annual variations in the earth's magnetism. (See *Variations, Magnetic, Annual.*)

Inequality, Diurnal, of Earth's Magnetic Variation or Inclination — — Diurnal variations in the value of the earth's magnetic variation or inclination. (See *Variation, Magnetic. Inclination, Magnetic.*)

Inequality, Diurnal, of Earth's Magnetism — — Inequalities or variations in the value of the earth's magnetism, dependent on the position of the sun during the earth's rotation.

Inequality, Lunar, of Earth's Magnetic Variation or Inclination — — Small variations in the value of the magnetic variation or inclination, dependent on the position of the moon as regards the magnetic meridian.

Inequality, Lunar, of Earth's Magnetism — — Small variations in the value of the earth's magnetism dependent on the position of the moon as regards the magnetic meridian.

Inertia.—The inability of a body to change its condition of rest or motion, unless some force acts on it.

The inertia of matter is expressed in Newton's first law of motion, as follows:

“Every body tends to preserve its state of rest or of uniform motion in a straight line, except in so far as it is acted on by an impressed force.”

All matter possesses inertia.

Inertia, Electric — — A term sometimes employed instead of electro-magnetic inertia. (See *Inertia, Electro-Magnetic.*)

A term employed to indicate the tendency of a current to resist its stopping or starting.

By self-induction an electromotive force is produced in a wire or other conductor at the moment of starting the current in it that tends to oppose the starting of such current, and also an electromotive force at the moment of stopping the current, in such a direction as to prolong or continue the current. In other words, self-induction tends to retard the rise or fall of the current.

Fleming traces the following comparison between the moment of inertia of a rotating wheel and the energy of its rotation on the one side, and the inductance of a circuit and the electro-magnetic energy of the circuit on the other.

(1.) The angular momentum of a fly-wheel is equal to the numerical product of its moment of inertia and the angular velocity of the wheel. Similarly the electro-magnetic momentum is equal to the product of the inductance of the circuit by the current flowing through it at any instant.

(2.) The rate of change of the angular momentum of the wheel, at any instant, is a measure of the rotational force of the couple acting at that instant.

Similarly the rate of change of the electro-magnetic momentum of the circuit is the measure of the electromotive force acting on it so far as mere change of current is concerned, and irrespective of that part of the electromotive force required to overcome the ohmic resistance.

An electric current does not start or stop instantaneously. It requires time to do either, just as a stream of water or other fluid does, and it is this property which is referred to by the term electric inertia. Inertia does not appear to be possessed by electricity apart from matter. "It is doubtful," says Lodge, "whether electricity of itself, and disconnected from matter, has any inertia"

Inertia, Electro-Magnetic — — A term sometimes employed instead of inductance, or the self-induction of a current. (See *Inductance, Inertia, Electric.*)

Inertia, Electro-Magnetic, Co-efficient of — — A term sometimes employed in place of the co-efficient of inductance or self-inductance of a circuit.

Inertia, Magnetic — — The inability of a magnetic core to instantly lose or acquire magnetism.

A magnet core tends to continue in the magnetic state in which it was placed.

The magnetic inertia is sometimes called the magnetic lag.

To decrease the magnetic inertia, the strength of the magnetizing current is increased and the length of the iron core decreased. The iron should also be quite soft. (See *Lag, Magnetic Force, Coercive.*)

Inferred Zero.—(See *Zero, Inferred.*)

Infinity Plug.—(See *Plug, Infinity.*)

Influence.—A term sometimes used instead of electrostatic induction. (See *Induction, Electrostatic.*)

The word influence is used by some to apply to the case of electrostatic induction, as distinguished from electro-magnetic or magnetic induction.

Influence Charge.—(See *Charge, Influence.*)

Influence Machine.—(See *Machine, Influence.*)

Inker, Morse — — A form of telegraphic ink-writer. (See *Ink-Writer, Telegraphic.*)

Ink-Writer, Telegraphic — — A device employed for recording the dots and dashes of a telegraphic message in ink on a fillet or strip of paper.

A telegraphic ink-writer is a form of telegraphic recorder. (See *Recorder, Morse.*)

Inside Wiring.—(See *Wiring, Inside.*)

Insolation, Electric — — A term sometimes employed for electric sunstroke, or electric prostration. (See *Sunstroke, Electric, Prostration, Electric.*)

Installation.—A term embracing the entire plant and its accessories required to perform any specified work.

The act of placing, arranging or erecting a plant or apparatus.

Installation, Electric — — The establishment of any electric plant.

An electric light installation, for example, includes the steam engine and boilers, or other prime movers, the dynamo-electric machines, the line wires or leads, and the lamps.

Insulated Body.—(See *Body, Insulated.*)

Insulating Cements.—(See *Cements, Insulating.*)

Insulating Sleeve.—(See *Sleeve, Insulating.*)

Insulating Stool.—(See *Stool, Insulating.*)

Insulating Tape.—(See *Tape, Insulating.*)

Insulating Tube.—(See *Tube, Insulating.*)

Insulating Varnish.—(See *Varnish, Electric.*)

Insulation, Electric — —Non-conducting material so placed with respect to a conductor as to prevent the loss of a charge, or the leakage of a current.

In the case of coils the character of the insulation of the coil of wires through which the current is to pass must be considered from the standpoint of the cooling of the coil by radiation.

In considering the safest and most economical current density to employ in any dynamo or motor, the depth of the coil, *i. e.*, the thickness of its coils, must be considered, as well as the character of the materials employed for the insulation. Such substances as silk or wool, which are characterized by low heat conduction, retain the heat longer than cotton. Hence the depth of a silk covered coil should necessarily be less than that of one covered with cotton.

Insulation Joint.—(See *Joint, Insulation.*)

Insulation, Porous — —An insulating material containing air or gas placed between the conductor and the insulating covering.

A strip of perforated paper is used for covering the bare conductor, and the insulating material is placed on the outside of this; or, a cord is wrapped separately around the conductor, and the insulating material is placed on the outside of this. By these means, as will be seen, a layer of air exists between the conductor and its insulating covering.

Insulation Resistance.—(See *Resistance, Insulation.*)

Insulation, Static — —A term employed in electro-therapeutics for a method of treatment by convection streams or dis-

charges, in which the patient is seated on an insulated stool connected to one pole or electrode of an influence machine, while the other pole or electrode is connected to the ground.

Insulator Cap.—(See *Cap, Insulator.*)

Insulator, Dice-Box — —A name sometimes applied to a double-cone insulator. (See *Insulator, Double-Cone.*)

Insulator, Double-Cone — —An insulator in which the line wire passes through and is supported by means of a tube consisting of two inverted cones joined at their smaller bases.

Insulator, Double-Cup — —An insulator consisting of two funnel-shaped cups, placed in an inverted position on the supporting pin and insulated from one another by a free air space, except near the ends, which are cemented.

The wire is wrapped in a groove on the outside of the outer cup. This possesses the advantage of exposing it to the rain, which thus cleanses the insulator and improves its power of insulation. The inner cup is supported on a pin and the outer cup cemented to it. Any leakage must, therefore, pass over the entire surface of both cups.

Insulator, Double-Shackle — —A form of insulator used in shackling a wire, consisting of two single-shackle insulators.

Insulator, Double-Shed — —A double-cup insulator. (See *Insulator, Double-Cup.*)

Insulator, Fluid — —An insulator provided with a small, internally placed, annular, cup-shaped space, filled with an insulating oil, thus increasing the insulating power of the support.

The line wire is wrapped in a groove on the outside of the insulator. Any surface leakage between the wire and ground in wet weather must occur between the outer surface of the insulator, which is kept cleansed by the rain, and the inner surface, where it is supported by the pin. But to do this, the current must cross the oil in the cup, which, from its high power of insulation, effectually prevents leakage.

Insulator, Invert — —An insulator

placed on the top of the wire instead of underneath it, as was formerly done.

Insulator, Oil — —A fluid insulator filled with oil. (See *Insulator, Fluid*.)

Insulator Pins.—(See *Pins, Insulator*.)

Insulator, Single-Shackle — —A form of insulator used for shackling a wire. (See *Shackling a Wire*.)

Insulator, Single-Shed — —An insulator with a single inverted cup.

The wire is wrapped around a groove on the outside of the cup, where it is exposed to the cleansing action of the rain. The cup is inverted and supported on a pin, to which it is screwed and cemented.

Insulator, Telegraphic or Telephonic — —A non-conducting support of telegraphic, telephonic, electric light or other wires.

Insulators are generally made of glass, earthen-

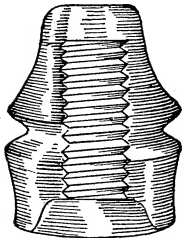

Fig. 310. Glass Insulator.

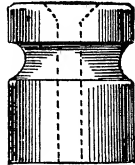

Fig. 311. Porcelain Insulator.

ware, porcelain or hard rubber, and assume a variety of forms, some of which are shown in Figs. 310, 311 and 312. Of whatever material they are made, it is necessary that the surface on which the wire rests, or around which it is wrapped, should be smooth, so as to avoid abrasion, either of its insulating covering or of the wire itself.

Two things are to be considered in the selection of an insulator, viz.:

(1.) The insulating power of the material of which the insulator is composed, so as to reduce the leakage as much as possible. (See *Leakage, Electric*.)

(2.) The tensile strength of the material. so

that in case of heavy wires no breaks may result from the fracture of the insulator.

Some forms of insulators are shown in Figs. 310, 311 and 312. They are screwed to the pins by the threads shown. The insulating materials of which they are formed are of glass, porcelain and hard rubber respectively.

Insulator, Window-Tube — —A tube of vulcanite or other insulating material provided for the insulation of a wire entering a room.

The wire conductor passes through the middle of the tube, which is firmly fixed in an opening passing through the window frame.

Insulator, Z — —A form of double-cup insulator in which the insulating material, earthenware or porcelain, is made in a single piece, instead of in two separate pieces.

The body of the insulator is conical in form, and the interior air space presents a shape approximately that of the letter Z.

The double form is used in order to diminish the leakage.

Intensity Armature.—(See *Armature, Intensity*.)

Intensity, Connection of Voltaic Cells for — —A term formerly employed for series-connected voltaic battery cells. (Obsolete.)

Intensity, Magnetic — —Density of magnetic induction.

Magnetic flux per square centimetre.

A committee of the American Institute of Electrical Engineers on "Units and Standards," proposes the following definition for magnetic intensity:

The induction density at a point within an element of surface is the surface differential at that point.

The practical unit of magnetic intensity is 10^8 or 100,000,000 C. G. S. lines per square centimetre.

In practice, excluding the earth's field, intensities range from 100 to 20,000 C. G. S. lines per square centimetre, and the working unit should, perhaps, have the prefix milli or micro.

Intensity, Magnetic, Pole of — —The earth's magnetic poles as determined by means of the oscillations of a magnetic needle.

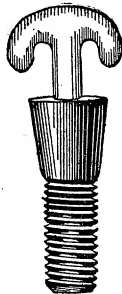

Fig. 312. Hard Rubber Insulator.

The points of the earth's greatest magnetic intensity.

Intensity of Current.—(See *Current, Intensity of*.)

Intensity of Field.—(See *Field, Intensity of*.)

Intensity of Light.—(See *Light, Intensity of*.)

Intensity of Magnetization.—(See *Magnetization, Intensity of*.)

Intensity, Photometric, Unit of — — The amount of light produced by a candle that consumes two grains of spermaceti wax per minute. (See *Candle*.)

Inter Air Space.—(See *Space, Inter Air*.)

Intercrossing.—In a system of telephonic communication, a device for avoiding the disturbing effects of induction by alternately crossing equal sections of the line. (See *Connection, Telephonic Cross*.)

Interference of Electro-Magnetic Waves.—(See *Waves, Electro-Magnetic, Interference of*.)

Interlocking Apparatus.—(See *Apparatus Interlocking*.)

Intermittent Contact.—(See *Contact, Intermittent*.)

Intermittent Cross.—A form of electric cross. (See *Cross, Electric*.)

Intermittent Current.—(See *Current, Intermittent*.)

Intermittent Disconnection.—(See *Disconnection, Intermittent*.)

Intermittent Earth.—(See *Earth, Intermittent*.)

Internal Circuit.—(See *Circuit, Internal*.)

Internal Polarization of Moist Bodies.—(See *Polarization, Internal, of Moist Bodies*.)

Interrupter.—Any device for interrupting or breaking a circuit.

Interrupter, Automatic — — An automatic contact breaker. (See *Make-and-Break, Automatic*.)

Interrupter, Reed — — A term sometimes applied to a tuning-fork interrupter. (See *Interrupter, Tuning-Fork*.)

Interrupter, Tuning-Fork — — An interrupter in which the successive makes and breaks are produced by the vibrations of a tuning-fork or reed.

The tuning-fork or reed is maintained in vibration by any suitable means. Such interrupters are applied to various uses. Synchronous multiplex telegraphy affords an example of such uses.

Invariable Calibration of Galvanometer.—(See *Calibration, Invariable, of Galvanometer*.)

Inverse Electromotive Force.—(See *Force, Electromotive, Inverse*.)

Inverse or Make-Induced Current.—(See *Current, Make-Induced*.)

Inverse Secondary Current.—(See *Current, Inverse Secondary*.)

Inversion, Thermo-Electric — — An inversion of the thermo-electric electromotive force of a couple at certain temperatures. (See *Diagram, Thermo-Electric*.)

Invert Insulator.—(See *Insulator, Invert*.)

Inverted Induction Coil.—(See *Coil, Induction, Inverted*.)

Inverted Type of Dynamo.—(See *Dynamo, Inverted*.)

Invisible Electric Floor Matting.—(See *Matting, Invisible Electric Floor*.)

Ions.—Groups of atoms or radicals which result from the electrolytic decomposition of a molecule.

The ions are respectively electro-positive and electro-negative. The electro-positive ion appears at the plate connected with the *electro-negative terminal*, or at the *cathode*, and is called the *kathion*.

The electro-negative ion appears at the plate connected with the *electro-positive terminal*, or at the *anode*, and is called the *anion*. (See *Electrolysis, Kathion, Anion*.)

Ions, Electro-Negative — — The negative atoms, or groups of atoms, called radicals, into which the molecules of an electro-

lyte are decomposed by electrolysis. (See *Electrolysis*.)

The electro-negative ions are called the anions, because they appear at the anode of a decomposition cell. (See *Anions. Anode*.)

Ions, Electro-Positive — —The positive atoms, or groups of atoms, called radicals, into which the molecules of an electrolyte are decomposed by electrolysis. (See *Electrolysis*.)

The electro-positive ions are called the kathions, because they appear at the kathode of a decomposition cell. (See *Kathion. Kathode*.)

Iron-Clad Electro-Magnet.—(See *Magnet, Electro, Iron-Clad*.)

Iron-Clad Magnet.—(See *Magnet, Iron-Clad*.)

Iron Core, Effect of, on the Magnetic Strength of a Hollow Coil of Wire — — An increase in the number of lines of magnetic force, beyond those produced by the current itself, due to the opening out of the closed magnetic circuits in the atoms or molecules of the iron.

The atoms or molecules of the iron possess naturally closed magnetic circuits, or closed lines of magnetic force, lying entirely within the mass of the iron. When the iron is placed in a magnetic field, these minute closed circuits open out and are added to the lines of force produced by the circuit itself. The opening out of these closed atomic or molecular lines of magnetic force is attended by the formation of lines of polarized molecules or atoms.

Roughly speaking, according to Lodge, for each single line of magnetic force produced by the electric current, there are some 3,000 lines of magnetic force added to it from the iron, the exact number varying with the kind of iron, the physical condition of the iron and the degree of magnetization.

Iron, Galvanized — —Iron covered by a layer of zinc by dipping it in a bath of molten zinc.

The process of galvanizing iron is designed to prevent the corrosion or rusting of the iron on exposure to the air. (See *Metals, Electrical Protection of*.)

The word galvanized probably had its origin in

an assumed galvanic or voltaic action, in causing the zinc to adhere to the iron. The true galvanic or voltaic action, viz., the galvanic protection, comes after the galvanizing process is completed.

Iron-Work Fault of Dynamo.—(See *Fault, Iron-Work, of Dynamo*.)

Irreversible Heat.—(See *Heat, Irreversible*.)

Irritability, Electric — —Irritability of nervous or muscular tissue by an electric discharge.

Irritability, Electric, Diminished — — A decreased irritability of nervous or muscular tissue, produced by an electric current of given strength.

Diminished electric irritability is often present in certain diseases of the motor apparatus.

Irritability, Electric, Increased — — An irritability of nervous or muscular tissue produced by a much weaker electric current than that required to produce it in normal tissue.

Irritability, Faradic — —Muscular contractions produced by the action of a faradic current on a nerve.

The action of the faradic current is to cause a prolonged tonic contraction, which continues while the current continues. Though the natural action is to produce a contraction, followed by a relaxation on each make and break, yet the makes and breaks follow one another so rapidly that the relaxation has not time to occur before the next contraction follows.

Irritability, Galvanic — —Muscular contractions produced by the action of a galvanic current.

The action of a galvanic current is to cause a single, quick, momentary contraction of a muscle on each starting or completion of the circuit.

The contractions are stronger in the case of galvanic currents when the direction of the current is reversed with a commutator instead of by an actual break at the poles. Such a break is called a voltaic alternative, and the currents so produced *voltaic alternatives*. (See *Alternatives, Voltaic*.)

Isobaric Lines.—(See *Lines, Isobaric*.)

Isobars.—Lines connecting places on the

earth's surface which have the same barometric pressure.

The isobaric lines are generally corrected for differences of elevation of the surface.

Isobars are often called isobaric lines.

A study of the isobaric lines, or isobars, is of great assistance in making forecasts or predictions of coming changes in the weather.

Isochasmic Curves.—(See *Curves, Isochasmic*.)

Isochronism.—Equality of time of vibration or motion.

Isochronize.—To produce equality of time of vibration or motion.—(See *Isochronism*.)

Isochronizing.—Producing equality of time of vibration or motion. (See *Isochronism*.)

Isochronous Vibrations or Oscillations.—(See *Vibrations or Oscillations, Isochronous*.)

Isoclinic Chart.—(See *Chart, Inclination*.)

Isoclinic Lines.—(See *Lines, Isoclinic*.)

Isodynamic Chart.—(See *Chart, Isodynamic*.)

Isodynamic Lines.—(See *Lines, Isodynamic*.)

Isodynamic Map.—(See *Chart, Isodynamic*.)

Iso-Electric Points.—(See *Points, Iso-Electric*.)

Isogonal.—Pertaining to the isogonic lines.

Isogonal Lines.—(See *Lines, Isogonal*.)

Isogonal Map or Chart.—(See *Map or Chart, Isogonal*.)

Isogonic.—Pertaining to the isogonic lines.

Isogonic Chart.—(See *Chart, Isogonic*.)

Isogonic Lines.—(See *Lines, Isogonic*.)

Isogonic Map.—(See *Map, Isogonic*.)

Isolated Electric Lighting.—(See *Lighting, Electric, Isolated*.)

Isolatine.—A kind of insulating material.

Isothermal Surfaces.—(See *Surfaces, Isothermal*.)

Isotropic Conductor.—(See *Conductor, Isotropic*.)

Isotropic Medium.—(See *Medium, Isotropic*.)

J

J.—A contraction proposed for Joule.

Jablochkoff Candle.—(See *Candle, Jablochkoff*.)

Jacketed Magnet.—(See *Magnet, Jacketed*.)

Jacobi's Law.—(See *Law, Jacobi's*.)

Jar, Electric — —A name formerly given to the Leyden jar.

Jar, Leyden — —A condenser in the form of a jar, in which the metallic coatings are placed opposite each other on the outside and the inside of the jar respectively.

The metal coatings should not extend to more than two-thirds of the height of the jar, the rest of the glass being varnished to avoid the creeping of the charges over the glass in damp weather. The inside coating is connected by means of a

metallic chain to a knob on the top of the jar, as shown in Fig. 313. The conductor supporting the knob passes through a dry cork or plug of some insulating material.

To charge the jar, the outside coating is connected with the earth, as by holding it in the hand, and the outside coating is connected with the conductor of a machine. (See *Condenser, Accumulator*.)

The inner coating of the jar is usually connected with the knob by means of a chain or wire as shown above. This necessitates a support for the ball and stem, which is generally obtained by a cork or wooden plug inserted in the mouth of

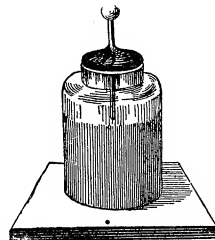

Fig. 313. Leyden Jar.

the jar. Such a form, however, is extremely objectionable, since, although the top of the jar be covered with shellac varnish to avoid leakage, it affords but a poor insulation in damp weather, because both the metallic rod supporting the ball and

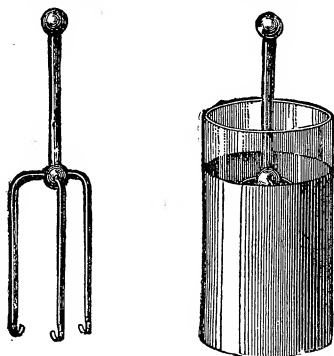

Fig. 314. Sir William Thomson's Leyden jar.

the damp wood or cork are in connection with the glass and thus facilitate leakage.

To overcome these objections a form of jar has been devised by Sir William Thomson, in which the knob is supported on three feet, which rest on the inner coating. In this form the uncoated glass can be readily kept dry and clean. This form is shown in Fig. 314.

A layer of sulphuric acid is sometimes employed for the inner coating of the Leyden jar. This serves the double purpose of acting as a coating and an absorber of moisture during damp weather.

Jar, Leyden, Capacity of — —The quantity of electricity a Leyden jar will hold at a given difference of potential.

The capacity of a jar is equal to the quantity of electricity divided by the difference of potential such quantity produces in the jar; or the capacity $= \frac{Q}{V}$ where Q = the quantity, and V , the difference of potential.

Jar, Leyden, Coatings of — —(See *Coatings of Leyden Jar*.)

Jar, Lightning — —A Leyden jar, the coatings of which consist of metallic filings.

As the discharge passes, an irregular series of sparks appear, which somewhat resemble in their shape a lightning flash. Hence the origin of the term.

Jar of Secondary Cell.—The containing

vessel in which the plates of a single secondary cell are placed.

Jar, Porous — —A porous cell. (See *Cell, Porous*.)

Jar, Scintillating — —A Leyden jar, the coatings of which, instead of being formed of continuous sheets of tin-foil or other conducting substances, are formed of small pieces of such substances, placed at regular intervals on the glass or dielectric so as to leave a small space between them.

Such a jar has received the name of scintillating jar, because when discharged by connecting its two opposite coatings the discharge appears as minute sparks, which jump across the space between the metallic pieces.

Jar, Unit — —A small Leyden jar sometimes employed to measure approximately the quantity of electricity passed into a Leyden battery or condenser.

As shown in Fig. 315, the unit jar consists of a small Leyden jar j , whose outer coating is connected with a sliding metallic rod b , provided at each end with a rounded knob, and the inner coating of which is connected with a metallic knob c , placed as shown, inside a glass jar d , opposite a ball on the lower end of b .

When, now, the inside of the unit jar, or the end connected with c , is connected with the charging source, such as a machine, and the outside at a , is connected with the jar or jars to be charged, for every spark that passes between d and c , a definite quantity has passed a.

The value of this unit charge may be varied by varying the distance between d and c .

The smaller the unit jar is in proportion to the jar to be charged, and the shorter the distance between c and d , the more reliable are the comparative results obtained.

Jars, Leyden, Charging, by Cascade — —(See *Cascade, Charging Leyden Jars by*.)

Jet, Gas, Carcel Standard — —A lighted gas jet employed for determining the candle-power of gas by measuring the height

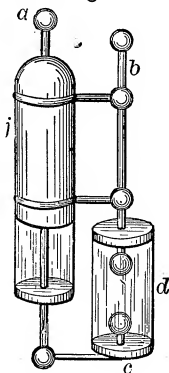

Fig. 315. Unit jar.

of a jet of gas burning under a given pressure, and used in connection with the light of a larger gas burner, burning under similar conditions, for the photometric measurement of electric lights.

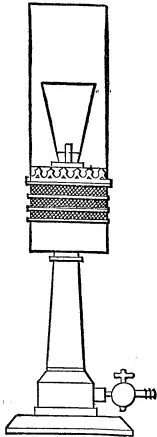

Fig. 316. Seven-Carcel Standard Gas Jet.

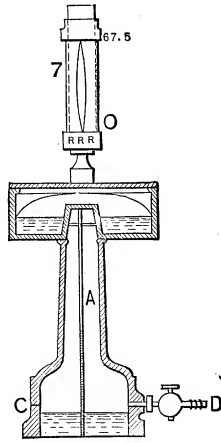

Fig. 317. Carcel Candle Burner.

In Fig. 316 is shown a section of a seven-carcel standard gas jet, and in Fig. 317, a section of a candle burner, connected within the same service pipe. The gas for both burners is received in a chamber, from whence it passes by an opening to the burner, under the constant pressure obtained by the weight of the bell C, and the tube A. The burner shown in Fig. 317, which is used as the standard of comparison, will give a candle-power determined from the height of the jet of the burning gas. This height is measured in millimetres by the motion of a circular screen.

The determination of the candle-power of gas by means of a jet photometer is only approximately correct, unless many precautions are taken.

Jet Photometer.—(See *Photometer, Jet.*)

Jewelry, Electric — Minute incandescent electric lamps substituted for the rarer gems in articles of jewelry.

The lamps are lighted by means of small primary or storage batteries, carried in the pocket or elsewhere on the person.

Joint, American Twist — —A telegraphic or telephonic joint in which each of the two wires is twisted around the other. (See *Joint, Telegraphic or Telephonic.*)

The twisted joint is sometimes subsequently soldered.



Fig. 318. American Twist Joint.

The American twist joint is shown in Fig. 318. This joint is easily made and is very serviceable.

Joint, Bell-Hanger's — —A joint for telegraphic or telephonic wires in which the ends are merely looped together. (See *Joint, Telegraphic or Telephonic.*)

Joint, Britannia — —A telegraphic or telephonic joint in which the wires are laid side by side, bound together and subsequently soldered. (See *Joint, Telegraphic or Telephonic.*)

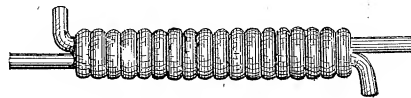

Fig. 319. Britannia Joint.

The Britannia joint is shown in Fig. 319. No. 16 wire, B. W. G., is used as the binding wire.

Joint, Butt — —An end-to-end joint.

A joint effected in wires by placing the wires end on and subsequently soldering.

Butt joints are formed by bringing the ends to be joined together and securing them while in such position.

Joint, Butt and Lap, of Belts — —The joint in a leather belt, employed for transmitting power from a line of shafting where the ends are simply brought together and laced, is called a butt joint, in contradistinction to a lap joint, or a joint formed by placing one end of the belt over the other and lacing or riveting the two.

In using delicate galvanometers, the slightest change in the speed of the engine driving the dynamo-electric machine producing the current, causes an annoying fluctuation of the needle that prevents accurate reading, when lap joints are used in the belt instead of butt joints, unless the former are very carefully made. Lap joints may also cause a flickering in the lights. When, however, lap joints are made by cutting the belt by an oblique section and properly securing them so that their

elevation at the joint is no greater than elsewhere, the lap joint is preferable to the butt joint.

Joint, Expansion — — A joint for underground conductors, tubes or pipes, exposed to considerable changes of temperature, in which a sliding joint is provided to safely permit a change of length on expansion or contraction.

Joint, Insulation — — A joint in an insulating material or covering in which a continuity is insured in the conducting as well as the insulating substance.

Joint, Lap — — A joint effected by overlapping short portions near the ends of the things to be joined, and securing them while in such position.

Joint, Lap, for Wires — — A joint effected between two wires by overlapping their ends and subsequently soldering.

Joint, Magnetic — — The line of junction between two separate parts of magnetizable material.

Magnetic joints should be of such a nature as to permit the passage of the lines of magnetic force with the least increase in the resistance of the magnetic circuit.

Magnetic joints in the field magnets of a dynamo-electric machine should be as few as possible, since the resistance of the best magnetic joint to the passage of the lines of force is necessarily greater than that of the same material without such joints.

Joint, Metallic Conducting — — A joint in a conductor in which a continuity of conducting power is secured.

Joint Resistance of Parallel Circuits. — (See *Resistance, Joint, of Parallel Circuits.*)

Joint, Sleeve — — A junction of the ends of conducting wires obtained by passing them through tubes and then twisting and soldering.

All joints should be soldered, but in so doing care must be taken that the soldering liquid or solid employed is free from acids or other corrosive materials, and that all traces of the soldering liquid or solid are removed from the wire before the joint is covered with insulating material.

Kerite, okonite or other insulating tape, should

preferably be wrapped around the joint after it is soldered.

In making a joint in a gutta-percha covered wire, such as a submarine cable, the following method may be employed: The bared and cleansed wires are twisted together and soldered. The soldered joint is then covered with a layer of plastic insulating material made of a mixture of gutta-percha, tar and rosin. (See *Chatterton's Compound.*) In order to insure a good junction between this and the gutta-percha covering on the rest of the wire, the outer surface of the gutta-percha is removed for about two inches from each side of the joint, so as to remove its oxidized surface. After the coating is put on, it is warmed gently by a warm joining tool, not by the flame of a lamp. A sheet of warmed gutta-percha is then wrapped around the joint, and while it and the joint are still hot, another coating of the plastic insulating material is applied. Successive layers of gutta-percha and some other insulating material are generally applied in the case of submarine cables.—(*Culley.*)

Joint, Telegraphic, McIntire's Parallel Sleeve — — A joint for telegraphic or other wires, in which the ends to be joined are slipped into parallel sleeves or tubes, which are afterward twisted around each other.

A general view of the parallel sleeve joint, both before and after twisting, is shown in Fig. 320.

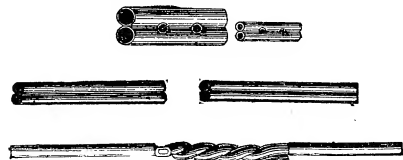

Fig. 320. McIntire's Parallel Sleeve Joint.

The twisting is done by means of the specially devised twisting clamp shown in Fig. 321.



Fig. 321. Twisting Clamp for McIntire's Parallel Joint.

Joint, Telegraphic or Telephonic — — A juncture of the ends of two electric conductors so as to insure a permanent junction whose resistance shall not be appreciably greater per unit of length than that of the rest of the wire.

In making a joint, care should always be taken to scrape the insulating material from the wires and clean their surfaces before twisting them together.

Telegraph wires were formerly joined by the ordinary bell-hangers' joint; that is, the wires were simply looped together. The constant vibrations to which the wires are subjected caused such a joint to be abandoned and an improvement introduced by bolting the ends together, as shown in Fig. 322.



Fig. 322. Telegraphic joint.

Joint, Testing of—Ascertaining the resistance of the insulating material around a joint in a cable.

The resistance of the insulating material of a cable at a joint is necessarily high, since the joint forms but a small part of length of the cable. It should not, however, be large as compared with an equal length of another part of the cable with a perfect core.

Two methods for testing cable joints are generally employed, viz.:

(1.) A conductor is charged through the joints for a given time, and the deflection obtained by its discharge compared with the discharge of the same condenser charged for an equal length of time through a few feet of perfect cable.

(2.) A charged conductor is permitted to discharge itself through the joint, and the amount lost in a given time noted.

For description of different methods, see Kempe's "Handbook of Electrical Testing."

Joulad.—A term proposed for the Joule.

This term is not generally adopted. (See *Joule*.)

Joule.—The unit of electric energy or work.

The volt-coulomb.

The amount of electric work required to raise the potential of one coulomb of electricity one volt.

The joule may be regarded as a unit of energy or work in general, apart from electrical work or energy.

1 joule.....	= 10,000,000 ergs.
1 joule.....	= .73732 foot-pounds.
1 joule.....	= 1 volt-coulomb.
1 joule.....	= .24 calorie.
4.2 joules.....	= 1 small calorie.
1 joule per second	= 1 watt.

The British Association proposed to call one joule the work done by one watt in one second.

Joule, as a Heat Unit.—The quantity of heat developed by the passage of a current of one ampère through a resistance of one ohm. (See *Joule*.)

Joule Effect.—(See *Effect, Joule*.)

Joule's Cylindrical Electro-Magnet.—(See *Magnet, Electro, Joule's Cylindrical*.)

Joule's Law.—(See *Laws of Joule*.)

Junction Box.—(See *Box, Junction*.)

Jump-Spark Burner.—(See *Burner, Jump-Spark*.)

Junction, Thermo-Electric.—A junction between any thermo-electric couple. (See *Cell, Thermo-Electric*.)

K

K.—A contraction for electrostatic capacity. (See *Capacity, Electrostatic*.)

K. C. C.—In electro-therapeutics, a brief method of writing cathodic closure contraction, or the effects of muscular contraction observed at the kathode on the closure of a circuit.

K. D. C.—In electro-therapeutics, a brief method of writing cathodic duration con-

traction, or the effects of muscular contraction observed at the kathode after the current has been passing for some time.

K. W.—A contraction for kilo-watt. (See *Watt, Kilo*.)

Kaolin.—A variety of white clay sometimes employed for insulating purposes.

Jablochkoff sometimes employed kaolin between the parallel carbons of his electric candle

for the purpose of insulating them from each other. He also devised an electric lamp in which a spark of considerable difference of potential, obtained from an ordinary induction coil, was caused to raise a surface of kaolin to incandescence by passage over it.

Kapp Lines.—(See *Lines, Kapp*.)

Kartavert.—A kind of insulating material.

Katelectrotonus.—A word sometimes used instead of kathelectrotonus. (See *Kathelectrotonus*.)

Kathelectrotonic State.—(See *State, Kathelectrotonic*.)

Kathelectrotonic Zone.—(See *Zone, Kathelectrotonic*.)

Kathelectrotonus.—In electro-therapeutics, the condition of increased functional activity that occurs in a nerve in the neighborhood of the kathode or negative electrode. (See *Electrotonus*.)

Kathion.—The electro-positive ion, atom or radical into which the molecule of an electrolyte is decomposed by electrolysis. (See *Electrolysis, Ions*.)

Kathion is sometimes written *cathion*.

In electrolysis the *kathion*, or the electro-positive ion or radical, appears at the kathode or electro-negative electrode. Similarly, the *anion*, or the electro-negative ion or radical, appears at the anode or the electro-positive electrode.

Kathodal.—Pertaining to the kathode. (See *Kathode*.)

Kathode.—The conductor or plate of an electro-decomposition cell connected with the negative terminal or electrode of a battery or other source.

The word kathode is sometimes applied to the negative terminal of a battery or source, whether connected with a decomposition cell or not. It is preferable, however, to restrict its use to decomposition cells. (See *Anode*.)

The word kathode is sometimes written *cathode*.

Kathodic.—Pertaining to the kathode. (See *Kathode*.)

Kathodic Electro-Diagnostic Reactions.—(See *Reactions, Electro-Diagnostic*.)

Keeper of Magnet.—(See *Magnet, Keeper*

Kerite.—An insulating material.

Kerr Effect.—(See *Effect, Kerr*.)

Key Board.—(See *Board, Key*.)

Key, Capillary Contact — — A form of fluid contact in which the circuit is closed or broken by means of a wire which is dipped into or removed from the surface of a mass of mercury.

In order to avoid an increase in the resistance of the circuit, due to the formation of oxide of mercury, the contact surface of the mercury is kept covered with a layer of dilute alcohol.

Key, Discharge — — A key employed to enable the discharge from a condenser or cable to be readily passed through a galvanometer for purposes of measurement.

Key, Discharge, Kempe's — — A discharge key constructed as shown in Fig. 323.

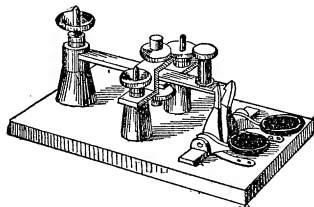

Fig. 323. Kempe's Discharge Key.

The solid lever, hinged at one extremity, plays between two contacts connected to two terminals, and has two finger triggers at its free end marked "Discharge" and "Insulate," connected respectively to two ebonite hooks. The hook attached to that marked "Discharge" is a little higher than the other, so that when the lever is caught against it, the key rests in an intermediate position between the contacts, and, when caught against the lower trigger, it rests against the bottom contact. When in the last position, a depression of the "Insulate" trigger causes the lever to spring up against the second hook, thus insulating it from either contact, and on the depression of the "Discharge" trigger, the lever springs up against the top contact.

Key, Discharge, Webb's — — A discharge key constructed as shown in Fig. 324.

A horizontal lever L, Fig. 324, passing between two contacts and hinged at J, is pressed upward by a spring. The free end of this lever terminates in two steps, 1 and 2. A vertical lever, pro-

vided with an insulating handle, is jointed at J', and has at C, a projecting metallic tongue that engages in the upper step when the lever H, is vertical, and on the lower step when it is slightly moved from the free end.

When the projection C, rests on the lower step 2, the lever L, is intermediate between the top and bottom contacts, and is, therefore, discon-

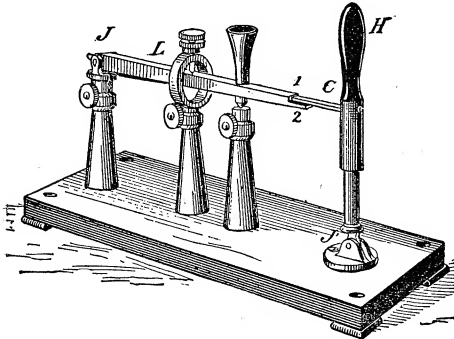

Fig. 324. Webb's Discharge Key.

nected from either of them; but, when it rests on the upper step, it is in contact with the lower contact.

When the lever H, is so moved as to have the projection C, away from both steps, the lever L, is pressed by its spring against the upper contact.

The battery terminals are connected with the condenser terminals when the lever L, is touching the lower contact, but when the lever L, touches the top contact, the condenser is connected with the galvanometer terminals.

Key, Double-Contact Form of Bridge, Sprague's — — A key designed to successively close two separate circuits.

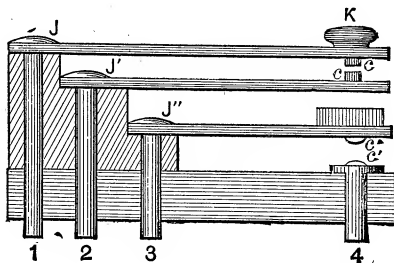

Fig. 325. Sprague's Double-Contact Key.

Sprague's double-contact key is shown in Fig. 325. On depressing K, the contacts c, c, are first closed and afterwards contacts at c', c'. Metallic

pieces, 1, 2, 3 and 4, serve to make contacts with apparatus used in connection with the key.

The battery circuit is connected to 1 and 2, and the galvanometer to 3 and 4, so that the battery circuit is closed first, and the galvanometer afterwards. This form of key is used in connection with the Wheatstone Bridge.

Key, Double-Contact, Lambert's — —

A key used in cable-work, and constructed as shown in Fig. 326.

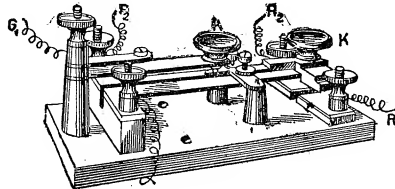

Fig. 326. Lambert's Double-Contact Key.

In Thomson's method for the determination of electrostatic capacity, the capacity of the cable is compared with that of a condenser containing a known charge. These two charges are so connected electrically as to discharge into and neutralize each other if equal, but if not, to produce a galvanometer deflection by a charge equal to their difference.

A Lambert double contact key is shown in Fig. 326. The connections are such that the pushing forward of K, depresses keys that permit a battery to simultaneously charge the condenser and the cable. On drawing K, back, the two charges are allowed to mix. Then on depressing K, the difference of the charges, if any, is discharged through the galvanometer.

Key, Double-Tapper — — The key used in a system of needle telegraphy to send electric impulses through the lines in alternately opposite directions. (See *Telegraphy, Single-Needle.*)

Key, Increment — — A telegraphic key so connected that an increase or increment in the line current occurs whenever the key is depressed.

The increment key is used in duplex and quadruplex systems of telegraphic transmission.

Key, Increment, of Quadruplex Telegraphic System — — A key employed to increase the strength of the current and so operate one of the distant instruments in a

quadruplex system by an increase in the strength of the current. (See *Telegraphy, Quadruplex.*)

Key, Magneto-Electric — —A telegraph key for sending an electric impulse into a line, so arranged that a coil of wire on an armature connected with the key lever is, by the movements of the key, moved toward or from the poles of a permanent magnet, the movements of the key thus producing the currents sent into the line.

Key, Plug — —A simple form of key in which a connection is readily made or broken by the insertion of a plug of metal between two metallic plates that are thus introduced into a circuit.

A form of plug key is shown in Fig. 327.

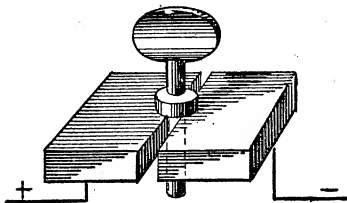

Fig. 327. Plug Key.

Key, Reversing — —A key inserted in the circuit of a galvanometer for obtaining deflections of the needle on either side of the galvanometer scale.

A form of reversing key is shown in Fig. 328. The galvanometer terminals are connected to the binding posts 2 and 3, and the circuit terminals to the other two posts. On depressing K, the

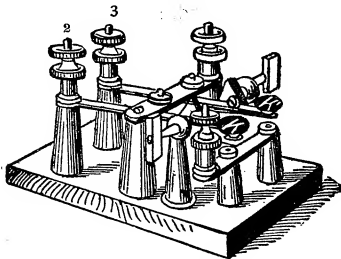

Fig. 328. Reversing Key.

current flows in one direction and on depressing K, it flows in the opposite direction. Clamps, operated by handles, are provided so as to close either of the keys permanently, if so desired.

Key, Reversing, of Quadruplex Telegraphic System — —A key employed to reverse the direction of the current and so operate one of the distant instruments, in a quadruplex system, by a change in the direction of the current. (See *Telegraphy, Quadruplex.*)

Key, Short-Circuit — —A key which in its normal condition short circuits the galvanometer.

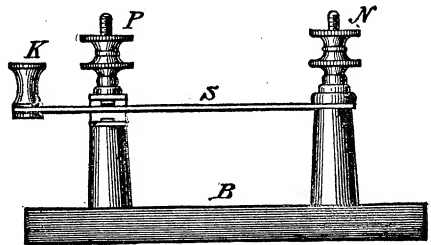

Fig. 329. Short-Circuit Key.

Such a short-circuit key is provided for the purpose of protecting the galvanometer from injury by large currents being accidentally passed through its coils. In the form shown in Fig. 329, the spring S, rests against a platinum contact; but when depressed by the insulated head at K, it rests against an ebonite contact, and throws the galvanometer into the desired circuit.

The key is provided with double binding posts at P and N, for convenience of attachment to resistance coils, batteries, etc.

In the form of a short-circuit key shown in Fig. 330, a catch is provided for the purpose of keeping the key down when once depressed. Its arrangement will be readily understood from an inspection of the figure.

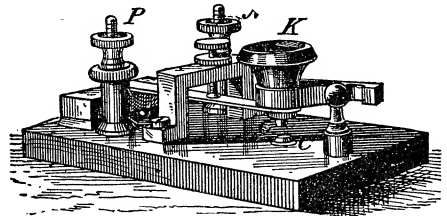

Fig. 330. Short-Circuit Key.

Key, Sliding-Contact — —The key employed in the slide form of Wheatstone bridge, to make contact with the wire over which the sliding contact passes. (See *Bridge, Electric, Slide Form of.*)

Key, Stationary Floor — —An electric key or push button placed on the floor so as to be readily closed by the foot.

This form of key is especially suitable for use in connection with an electric bell and annunciator for readily calling an attendant. (See *Annunciator, Electro-Magnetic.*)

Key, Telegraphic — —The key employed for sending over the line the successive makes and breaks that produce the dots and dashes of the Morse alphabet, or the deflections of the needle of the needle telegraph. (See *Telegraphy, American System of.*)

Kick.—A recoil.

Kicking Coil.—(See *Coil, Kicking.*)

Kilo (*as a prefix*).—One thousand times.

Kiloampère.—One thousand ampères.

Kiloampère Balance.—(See *Balance, Kiloampère.*)

Kilodyne.—One thousand dynes. (See *Dyne.*)

Kilogramme.—One thousand grammes, or 2.2046 pounds avoirdupois. (See *Weights, French System of.*)

Kilojoule.—One thousand joules.

Kilometre.—One thousand metres.

Kilowatt.—One thousand watts.

Kilowatt Hour.—(See *Hour, Kilowatt.*)

Kine.—A unit of velocity proposed by the British Association.

A kine equals 1 centimetre per second.

Kinetic Energy.—(See *Energy, Kinetic.*)

Kinetic Theory of Matter.—(See *Matter, Kinetic Theory of.*)

Kinetics, Electro — —A term sometimes applied to the phenomena of electric currents, or electricity in motion, as distinguished from electrostatics, or the phenomena of electric charges, or electricity at rest.

Kinetograph.—A device for the simultaneous reproduction of a distant stage and its actors under circumstances such that the actors can be heard at any distance from the theatre.

The sounds heard by the distant audience are actual reproductions of those uttered during the

performance, though not at the time of their utterance. The appearance of the stage and its actors represents the appearance of a previous reproduction of the play or opera or other performance, as taken by means of a Kodak camera with a film cylinder and drop shutter, operated by an electric motor, exposing, say, forty plates a second. By means of a projecting lantern these photographic pictures are thrown on a curtain on a stage at the distant theatre in regular order of sequence, while a loud-speaking phonograph puts song and speech into the mouths of the mimic actors and thus gives the phantom stage the semblance of life and reality.

Kite, Franklin's — —A kite raised in Philadelphia, Pa., in June, 1752, by means of which Franklin experimentally demonstrated the identity between lightning and electricity, and which, therefore, led to the invention of the lightning rod.

It is true that Dalibard, on the 10th of May, 1752, prior to Franklin's experiment, succeeded in drawing sparks from a tall iron pole he had erected in France. This experiment was, however, tried at the suggestion of Franklin, to whom it must properly be ascribed.

A description of this kite is given by Franklin in the following letter:

Letter XI, from BENJ. FRANKLIN, Esq., of Philadelphia, to PETER COLLINSON, Esq.,
F. R. S., London.

“OCT. 19, 1752.

“As frequent mention is made in public papers, from Europe, of the success of the Philadelphia experiment for drawing the electric fire from clouds by means of pointed rods of iron erected on high buildings, etc., it may be agreeable to the curious to be informed that the same experiment has succeeded in Philadelphia, though made in a different and more easy manner, which is as follows:

“Make a small cross of two light strips of cedar, the arms so long as to reach to the four corners of a large thin handkerchief when extended; tie the corners of the handkerchief to the extremities of the cross, so you have the body of a kite, which, being properly accommodated with a tail, loop and string, will rise in the air like those made of paper, but this, being of silk, is fitter to bear the wet and wind of a thunder gust without tearing. To the top of the upright stick of the cross is to

be fixed a very sharp pointed wire rising a foot or more above the wood. To the end of the twine, next the hand, is to be tied a silk ribbon, and where the silk and twine join, a key may be fastened. This kite is to be raised when a thunder gust appears to be coming on, and the person who holds the string must stand within a door or window, or under some cover, so that the silk ribbon may not be wet, and care must be taken that the twine does not touch the frame of the door or window. As soon as any of the thunder clouds come over the kite the pointed wire will draw the electric fire from them, and the kite, with all the twine, will be electrified, and the loose filaments of the twine will stand out every way, and be attracted by an approaching finger. And when the rain has wet the kite and twine so that it can conduct the electric fire freely, you will find it stream out plentifully from the key on the approach of your knuckle. At this key the phial may be charged, and from electric fire thus obtained spirits may be kindled, and all the other electric experiments be performed, which are usually done by the help of a

rubbed glass globe or tube, and thereby the sameness of the electric matter with that of lightning completely demonstrated.

“B. FRANKLIN.”

Knife Break Switch.—(See *Switch, Knife Break.*)

Knot or Nautical Mile.—A length equal to 6,087 feet.

The English statute mile is equal to 5,280 feet. The value of the nautical mile is therefore in excess of that of the statute mile.

Kohlrausch's Law.—(See *Law of Kohlrausch.*)

Krizik's Bars.—(See *Bars, Krizik's.*)

Kyanized.—Subjected to the kyanizing process. (See *Kyanizing.*)

Kyanizing.—A process employed for the preservation of wooden telegraphic poles by injecting a solution of corrosive sublimate into the pores of the wood. (See *Pole, Telegraphic.*)

L

L.—A contraction for co-efficient of inductance. (See *Inductance, Co-efficient of.*)

L.—A contraction for length.

Labile Galvanization.—(See *Galvanization, Labile.*)

Lag, Angle of — —The angle through which the axis of magnetism of the armature of a dynamo-electric machine is shifted by reason of the resistance its core offers to sudden reversals of magnetization.

An armature of a bi polar dynamo electric machine has its magnetism reversed twice in every rotation. The iron of the core resists these magnetic reversals. The result of this resistance is to shift the axis of magnetism in the direction of rotation. The angle through which the axis has thereby been shifted is called the *angle of lag*.

The term, angle of lag, is sometimes incorrectly applied so as to include a similar result produced by the magnetization due to the armature current itself. It is this latter action which, in armatures with soft iron cores, is the main cause of the angle

of lead. (See *Brushes, Lead of. Lead, Angle of.*)

Lag, Angle of, of Current — —An angle whose tangent is equal to the ratio of the inductive to the ohmic resistance.

An angle, the tangent of which is equal to the inductive resistance of the circuit, divided by the ohmic resistance of the circuit.

An angle, the co-sine of which is equal to the ohmic resistance of the circuit, divided by the impedance of the circuit.

Lag, Magnetic — —A magnetic viscosity as manifested by the sluggishness with which a magnetizing force produces its magnetizing effects in iron.

The tendency of the iron core of a magnet, or of the armature of a dynamo-electric machine, to resist, and, therefore, retard magnetization.

This retardation, or lag, is called the *magnetic lag*.

The lead necessary to give the brushes of a dynamo-electric machine to insure quiet action has by

some been erroneously ascribed to the magnetic lag. The lead, though due to lag in part, in reality is mainly due to the resultant magnetization of the armature both by the field magnets and by its own current. (See *Lead, Angle of.*) This displacement of the brushes is measured by an angle sometimes, though erroneously, called the angle of lag. (See *Lag, Angle of.*)

Lamellar Distribution of Magnetism.—(See *Magnetism, Lamellar Distribution of.*)

Laminated Core.
—(See *Core, Laminated.*)

Laminating Core.
—(See *Core, Lamination of.*)

Lamination of Armature Core.—
(See *Core, Armature, Lamination of.*)

Lamination of Cores.—(See *Core, Lamination of.*)

Lamp, All-Night
—A term sometimes applied to a double-carbon arc lamp. (See *Lamp, Electric Arc, Double-Carbon.*)

A form of all-night arc lamp is shown in Fig. 331. When the consumption of the first pair of carbons has reached a certain limit the current is automatically switched over to the other pair.

Lamp, All-Night Electric —A lamp provided with carbon electrodes so as to burn all night without recarboning.

A double-carbon electric lamp. (See *Lamp, All-Night.*)

Lamp, Arc —An electric lamp, the source of whose light is a voltaic arc.

Lamp, Arc, Electric —An electric lamp in which the light is produced by a voltaic arc formed between two or more carbon electrodes.

The carbon electrodes are placed in various positions, either parallel, horizontal, inclined to one another or vertically one above the other. The latter is the form most generally adopted, since it permits the ready feeding of the upper carbon.

The carbons are maintained during their consumption at a constant distance apart, by the aid of various *feeding devices*. Such devices are operated generally by trains of wheel-work, by mechanical or electrical motors, or by the simple action of a spring, by gravity or by the attraction of a solenoid.

The carbon pencils or electrodes are held in *carbon holders*, consisting of *clutches* or *clamps*, attached to the end of the *lamp rods*.

When the lamp is not in operation the carbons are usually in contact with one another; but, on the passage of the current, they are separated the required distance by the action of an electro-magnet whose coils are traversed by the direct or main current.

In order to maintain the electrodes a constant distance apart, the upper carbon in some lamps is held in position by the operation of a clutch, or, in others, by a detent, that engages in a toothed wheel. The position of this clutch or detent is controlled by the action of an electro-magnet whose coils are usually situated in a *shunt* or *derived circuit*, of high resistance, around the electrodes. When the carbons are at their normal distance apart, the shunt current is not of sufficient strength to move the clutch or detent from the position in which it prevents the downward motion of the upper carbon rod. When, however, by the burning or consumption of the carbons, the resistance of the arc has increased to an extent which can be predetermined, the increased current that is thereby passed through the shunt circuit is now sufficiently strong to release the clutch or detent, thus permitting the fall or feed of the upper carbon. In a well designed lamp this occurs

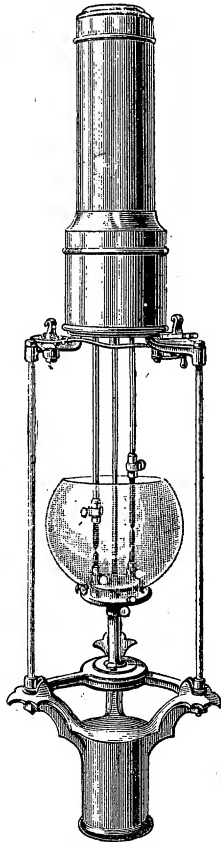

Fig. 331. All-Night Arc Lamp.

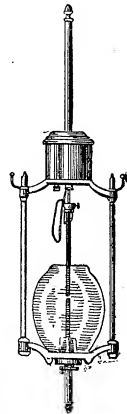

Fig. 332. Arc Lamp.

so gradually as to produce no perceptible effect on the steadiness of the light.

Arc lamps are generally placed in *series circuits*, that is, in circuits in which the current passes successively through all the lamps in the circuit, and returns to the source. In order to avoid the breaking of the entire circuit through the extinguishing of a single arc, on the breaking of its circuit, an *automatic safety device* is provided for each lamp. This safety device consists essentially of an electro-magnet so placed in a shunt circuit, that, as the resistance of the arc becomes too great, the increased current, which will then flow through the coils of the electro-magnet, at last produces a movement of its armature which closes a short circuit around the lamp, and thus cuts it out of the circuit.

Arc lamps assume a great variety of forms. A well known form is shown in Fig. 332.

Lamp, Arc, Triple Carbon — —An arc lamp in which three carbon electrodes are used.

The positive carbons consist of two ordinary cylindrical carbons, placed parallel to each other. The negative carbon is shaped like the figure 8. The arc is established between one of the positive carbons and the corresponding side of the negative carbon. The feeding of the lamp is attended by a shifting back and forth of the arc between the positive carbons and from side to side of the negative carbons.

The design of the triple carbon arc lamp is to produce a lamp of long life.

Lamp Bracket, Electric — —(See *Bracket, Lamp, Electric*.)

Lamp Bulb.—(See *Bulb, Lamp*.)

Lamp, Carcel — —An oil lamp employed in France as a photometric standard.

Fig. 333 shows a form of carcel lamp. Like the standard candle, the carcel is a standard only when it consumes a given weight of the light-producing substance in a given time.

Lamp, Chamber of — —
The glass bulb or chamber of an incandescing electric lamp in which the incandescing conductor is

placed, and in which is maintained a high vacuum.

The transparency of the lamp chamber and consequently the efficiency of the lamp may decrease—

(1.) From the settling of dust or dirt on its outer walls.

(2.) From the deposit of carbon or metal on its inner walls.

To obviate the first cause of diminished transparency the outside of the lamp chamber should be frequently cleansed. The diminished transparency, due to the second cause, cannot be removed. When it has reached a certain point, it is more economical to replace the old lamp by a new lamp.

In a properly made lamp the dimming of the lamp chamber is not apt to occur unless a stronger current than the normal current is passed through the lamp.

Lamp Clamp.—(See *Clamp for Arc Lamps*.)

Lamp, Contact — —A form of semi-incandescing electric lamp in which a carbon pencil is pressed against a slab of carbon or other refractory material.

The source of light in an electric contact lamp is twofold, viz.:

(1.) A minute arc formed at the points of imperfect contact.

(2.) The incandescence of the carbon pencil, and the points of the slab of carbon against which it is pressed.

Lamp Contacts.—(See *Contacts, Lamp*.)

Lamp, Electric, Arc, Carbon Electrodes for — —(See *Electrodes, Carbon, for Arc Lamps*.)

Lamp, Electric, Arc, Differential — —
An arc lamp in which the movements of the carbons are controlled by the differential action of two magnets opposed to each other, one of whose coils is in the direct and the other in a shunt circuit around the carbons.

Sometimes the differential coils are placed on the same magnet core.

Lamp, Electric, Arc, Double Carbon — —
—An electric arc lamp provided with two pairs of carbon electrodes, so arranged that when one pair is consumed, the circuit is automatically completed through the other pair.

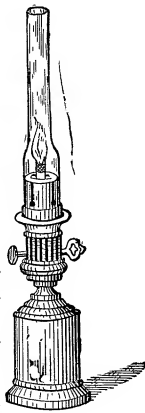

Fig. 333.
Carcel Lamp.

Lamp, Electric Glow — — A term employed mainly in Europe for an incandescent electric lamp. (See *Lamp, Electric, Incandescent*.)

Lamp, Electric, Incandescent — — An electric lamp in which the light is produced by the electric incandescence of a strip or filament of some refractory substance, generally carbon.

The carbon strip or filament is usually bent into the form of a horseshoe or loop, and placed inside a glass vessel called the lamp chamber. The lamp chamber is exhausted by means of a mercury pump, generally to a fairly high vacuum.

In order to insure the complete removal from the lamp chamber of all the air it originally contained, the carbon strips that are placed within it are maintained at a high temperature during the process of exhaustion. This temperature, in practice, is obtained by sending the current through the carbon strip as soon as nearly all the air is removed. Towards the end of the pumping operation the current is increased so as to raise the carbons to their full brilliancy.

The lamp chamber is also maintained at a fairly high temperature.

To insure this heating of the walls of the lamp chamber by the incandescent carbons during pumping, for the purpose of driving off all the air adhering to the walls of the chamber, they are sometimes covered with some readily removable preparation of lamp black.

The operation of driving off the gases absorbed by the carbons is termed the *occluded gas process*, and is essential to the successful sealing of an incandescent lamp. By its means, a considerable quantity of air or other gaseous substances shut up or occluded by the carbon is driven out of the carbon, which it would be impossible to get rid of by the mere operation of pumping. In order to insure the success of the operation, it is necessary that the heating must take place while the lamp is being exhausted, since otherwise the expelled gases would be re-absorbed. (See *Gas, Occlusion of*.)

Both the exhaustion and the incandescence continue up to the moment the lamp chamber is hermetically sealed; otherwise, some of the air might remain in the lamp chamber.

The lamp chamber is hermetically sealed, usually by the fusion of the glass in the manner

adopted in the sealing of Geissler tubes or Crookes' radiometers.

For the preparation of the carbon strip, its carbonization and the flashing of the strip, see *Carbonization, Processes of. Carbons, Flashing Process for*.

The ends of the carbon strip, or filament, are attached to *leading-in wires* of platinum that pass through the glass walls of the lamp chamber, and are fused therein by melting the glass around them in the same manner as are the leading-in wires of the Geissler tubes and other similar apparatus.

Incandescent lamps are generally connected to the leads or circuits in multiple-arc or in multiple-series. They are, however, sometimes connected to the line in series. (See *Circuits, Varieties of*.)

In the case of multiple-arc or multiple-series connection, the resistance of the filament is comparatively high. In the case of series-connection the resistance is comparatively low.

Incandescent electric lamps assume a variety of different forms. In all cases, however, the shape of the filament is such that the leading-in wires that carry the current to and from the filament shall enter and leave the lamp chamber at points that are comparatively near together. This is for the purpose of avoiding the unnecessary production of shadows.

Commercial incandescent electric lamps are generally marked with the potential difference in volts that must be applied at the terminals in order to furnish the current necessary to properly operate them. If this potential difference is made greater, the can-



Fig. 334. Incandescent Electric Lamp.

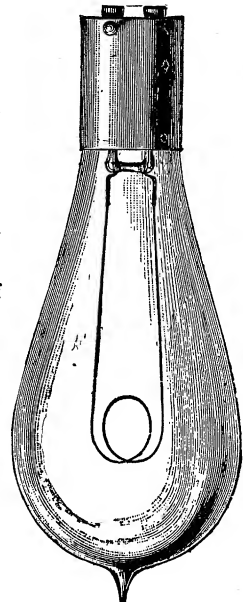

Fig. 335. Swan Incandescent Lamp.

able-power of the lamp is greatly increased, but its life greatly decreased.

The lamp chamber is more liable in such cases to become less transparent from the deposit of a thin layer of carbon or metal on its inner surfaces.

In the Swan lamp the filament is made of cotton thread. These threads are immersed in a mixture of two parts of sulphuric acid and one of water, which converts the cellulose of the thread into artificial parchment. The filaments are rapidly washed as soon as they are removed from the sulphuric acid until all traces of the acid are removed. They are then passed through discs so as to insure a uniform area of cross-section, and are then wrapped on rods of carbon or earthenware of the required outline, packed in a crucible filled with powdered charcoal, and carbonized.

The form generally given to the Swan filament is that shown in Fig. 335.

Lamp, Electric, Incandescent Ball —
—An incandescent electric lamp in which the light is produced by a sphere or ball of carbon placed in an exhausted receiver of glass.

When subjected to the effects of electrostatic waves of high frequency of alternation, such a lamp becomes luminous from the incandescence of the carbon ball or sphere. Tesla's incandescent ball electric lamp is a modification of his straight filament lamp. (See *Lamp, Incandescent, Straight Filament.*)

The construction of Tesla's ball incandescent electric lamp will be readily understood from an inspection of Fig. 336.

Lamp, Electric, Incandescent, Half-Shades for — (See *Half-Shades for Incandescent Lamps.*)

Lamp, Electric, Incandescent, Life of — —The number of hours that an incandescent electric lamp, when traversed by the normal current, will continue to afford a good commercial light.

The failure of an electric incandescent lamp results either from the volatilization or rupture of the carbon conductor, or from the failure of the

vacuum of the lamp chamber. Since the employment of the flashing process, and the process for removing the occluded gases, it is not unusual for incandescent lamps to have a life of several thousand hours. (See *Carbons, Flashing Process for.*)

The life of an incandescent electric lamp should not be considered as continuing until the filament actually breaks. As soon as the lamp chamber has become covered with such a deposit of carbon or coating of metal as to considerably decrease the amount of light which passes through the chamber, the lamp should be considered as useless.

Lamp, Electric, Incandescent, Three-Filament, for Multi-Phase Circuits —

—An incandescent lamp for use on multi-phase circuits, provided with three leading-in wires, connected to the free ends of three filaments, the other ends of which are connected in a common joint.

When properly acting, the current passing through each filament should, at any instant, equal the sum of the currents in the other two filaments, which, as is well known, is the property of any three-phase circuit.

Lamp, Electric, Outrigger for — —
(See *Outrigger for Electric Lamp.*)

Lamp, Electric, Pendant — —An incandescent electric lamp suspended by flexible twin-wire.

Lamp, Electric, Safety — —An incandescent electric lamp, with thoroughly insulated leads, employed in mines, or other similar places, where the explosive effects of readily ignitable substances are to be feared.

Such lamps are often directly attached to a portable battery, in which case they can be readily carried about from place to place.

Lamp, Electric, Semi-Incandescent — —
—An electric lamp in which the light is due to the combined effects of a voltaic arc and electric incandescence.

In the Reynier semi-incandescent lamp, shown in Fig. 337, a thin pencil of carbon C, is gently pressed against a block of graphite B. A lateral contact is provided at L, through a block of graphite I, by means of which the current is con-

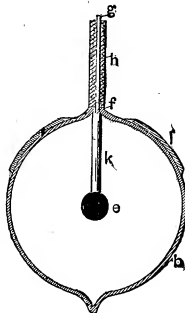

Fig. 336. Tesla's Incandescent Ball Electric Lamp.

veyed to the lower part only of the movable rod C, which part alone is rendered incandescent.

In this lamp, the light is due both to the incan-

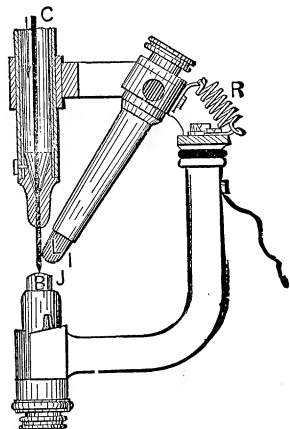

Fig. 337. Semi-Incandescent Lamp.

descence of the rod C, and to the small arc formed at J, between its lower end and the contact block B, though mainly from the latter. The semi-incandescent electric lamp has not as yet been introduced to any considerable extent.

Lamp, Electric, Series-Connected Incandescent — — An incandescent electric lamp adapted for use in series circuits.

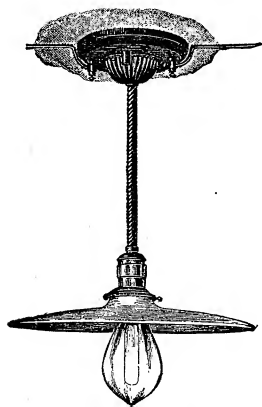

Fig. 338. Series Incandescent Electric Lamp.

A form of series incandescent lamp, attached to pendant and shade, is shown in Fig. 338.

In the series connected incandescent lamp, unlike the multiple-connected incandescent electric lamp, the resistance of the filament is low. This is done in order to prevent the total resistance of

the circuit from requiring too high an electromotive force for operation. In order to preserve the continuity of the circuit on the failure of any lamp to operate, some form of automatic cut-out is employed. This is generally some form of film cut-out. (See *Cut-Out, Film.*)

Lamp Hour.—(See *Hour, Lamp.*)

Lamp, Incandescent, Electric Filament of — — A term now generally applied to the incandescing conductor of an incandescent electric lamp, whether the same be of very small cross-section or of comparatively large cross-section.

The term filament is properly applied to a conductor containing fibres or filaments extending in the general direction of the length of the incandescing conductor. Such a conductor is made of carbonizable fibrous material, cut or shaped prior to carbonization so as to have its fibres extending with their greatest length in the direction of length of the filament.

Lamp, Incandescent, Straight Filament — — An incandescent electric lamp in which a straight filament, placed in an exhausted glass chamber, is rendered luminous by the effects of electrostatic waves or thrusts of high frequency.

The straight filament in incandescent lamp is the invention of Tesla. One form of such a lamp is shown in Fig. 339.

The glass globe b, of the lamp is provided with a cylindrical neck, inside of which is placed a tube m, of conducting material, on the side and over the end of the insulating plug n.

The light-giving filament e, is a straight carbon stem, connected to the plate by a conductor covered with a refractory insulating material k. An insulated tube-socket p, provided with a metallic lining s, serves to support the lamp and connect it with one pole of the source of current. It will be noticed that the coat-

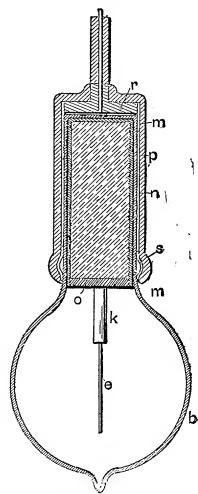

Fig. 339. Tesla's Straight Filament Incandescent Lamp.

ings *s* and *m*, form the plates of a condenser. The other terminal of the machine may be connected to the metal coated walls of the room, or to metallic plates suspended from the ceiling.

Lamp Indicator.—(See *Indicator, Lamp*.)

Lamp, Pilot — —In systems for the operation of electric lamps, an incandescent lamp employed in a station to indicate the difference of potential at the dynamo terminals, by means of the intensity of its emitted light.

Lamp Rod.—(See *Rod, Lamp*.)

Lamp Socket Switch.—(See *Switch, Lamp Socket*.)

Lamps, Bank of — —A term applied to a number of lamps, equal to about half the load, that were formerly placed in view of the attendant in circuit with a dynamo that is to be placed in a parallel circuit with another dynamo, one of the lamps of which is also in view.

When the lamps "in bank" were judged to be of the same brilliancy as the one fed by the other dynamo, the attendant switched the dynamo parallel with the other, and at the same time cut off the bank of lamps from the switched in dynamo.

The method is, however, wrong. The proper way is to make the voltage of the dynamo equal to that of the circuit. Then connect it and finally raise its electromotive force until it takes its share of the load.

Lamps, Carboning — —Placing carbons in electric arc lamps.

When the carbons are consumed, the lamp requires recarboning. The old carbon ends are replaced by new carbons, and the lamp rods cleansed.

Large Calorie.—(See *Calorie, Great*.)

Latent Electricity.—(See *Electricity, Latent*.)

Lateral Discharge.—(See *Discharge, Lateral*.)

Lateral Induction.—(See *Induction, Lateral*.)

Lateral Leakage of Lines of Magnetic Force.—(See *Leakage, Lateral, of Lines of Magnetic Force*.)

Lateral Magnetic Leakage.—(See *Leakage, Lateral, of Lines of Magnetic Force*.)

Latitude, Magnetic — —The distance a place is situated north or south of the magnetic equator.

All places that have the same magnetic latitude have the same value for the magnetic inclination and magnetic intensity, or are on the same isoclinical and isodynamic lines. The magnetic latitude is the same at all points of a magnetic parallel.

Launch, Electric — —A boat, the motive power for which is electricity, suitable for launching from a ship.

Up to the present time electric launches have been propelled by means of electric motors, driven by means of powerful storage batteries.

A form of electric launch constructed for the English Government is shown in Fig. 340. It is

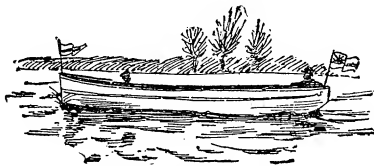

Fig. 340. Electric Launch.

48½ feet in length over all, by 8 feet 9 inches beam, with an average draft of 2 feet 3 inches. Its speed is 8 knots per hour. It will carry forty fully equipped soldiers.

Law, Jacobi's — —The maximum work done by a motor is reached when the counter-electromotive force is equal to one-half of the impressed electromotive force, or,

$$E = \frac{e}{2}$$

Law, Joule's — —The heating power of a current is proportional to the product of the resistance and the square of the current strength. (See *Heat, Electric*.)

Law, Natural — —A correct expression of the order in which the causes and effects of natural phenomena follow one another.

The law of gravitation, for example, correctly expresses the order of sequence of the phenomena which result when unsupported bodies fall to the earth. It should be carefully borne in mind, however, that natural laws cannot be regarded as explaining the ultimate causes of natural pheno-

mena, but merely express their order of occurrence or sequence.

We are ignorant, for example, of the true cause of gravitation and are only acquainted with its effects. This is true of all ultimate physical causes, save for our belief in their origin in a Divine will.

Law of Electro-Chemical Equivalence.

—(See *Equivalence, Electro-Chemical, Law of.*)

Law of Kohlrausch.—In electrolytic conduction, each atom has a rate of motion for a given liquid, which is independent of the element with which it may have been combined.

In the following table, the rate of motion of various kinds of atoms through nearly pure water for a difference of potential of one volt per linear centimetre, is given:

H.....	1.08	centimetres per hour.
K.....	0.205	centimetre “
Na.....	0.126	“ “
Li.....	0.094	“ “
Ag.....	0.166	“ “
C.....	0.213	“ “
I.....	0.216	“ “
NO ₃	0.174	“ “

Law of Ohm, or Law of Current Strength.

—The strength of a continuous current is directly proportional to the difference of potential or electromotive force in the circuit, and inversely proportional to the resistance of the circuit, *i. e.*, is equal to the quotient arising from dividing the electromotive force by the resistance.

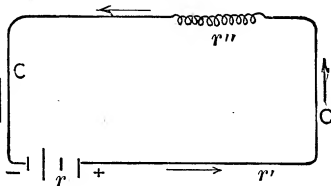

Fig. 341. Current Strength in Circuit.

Ohm's law is expressed algebraically thus:

$$C = \frac{E}{R}; \text{ or, } E = C R.$$

If the electromotive force is given in volts, and the resistance in ohms, the formula will give the current strength directly in ampères.

The resistance of any electric circuit, as, for example, that shown in Fig. 341, consists of three parts, viz.:

- (1.) The internal resistance of the source, *r*.
- (2.) That of the conducting wires or leads, *r'*; and
- (3.) That of the electro-receptive, *r''*, energized by the current. Ohm's law applied to this case would be:

$$C = \frac{E}{r + r' + r''}.$$

That is, the resistance of the entire circuit is equal to the sum of the separate resistances of its different parts.

Since $C = \frac{E}{R}$, (1); then $E = C R$, (2);

and $R = \frac{E}{C}$, (3).

But, since a current of one ampère is equal to one coulomb per second, then, in order to determine in coulombs the quantity of electricity passing in a given number of seconds, it is only necessary to multiply the current by the time in seconds, or $Q = C T$ (4).

Hence, referring to the above equations (1), (2), (3) and (4); according to Ohm's law:

- (1.) The current in ampères is equal to the electromotive force in volts divided by the resistance in ohms.
- (2.) The electromotive force in volts is equal to the product of the current in ampères and the resistance in ohms.
- (3.) The resistance in ohms is equal to the electromotive force in volts divided by the current in ampères.
- (4.) The quantity of electricity in coulombs is equal to the current in ampères multiplied by the time in seconds.

Law of Volta, or Law for Contact-Series.

—A law for the differences of electric potential produced by the contact of dissimilar metals or other substances.

“The difference of potential between any two metals is equal to the sum of the differences of potential between the intervening substances in the contact series.” (See *Electricity, Contact Series, Contact.*)

Law, Pfüger's — — A given tract of nerve is stimulated by the appearance of kathelectrotonus and the disappearance of anelectrotonus; not, however, by the disap-

pearance of kathelectrotonus nor by the appearance of anelectrotonus.—(*Landois and Stirling.*)

Law, Poynting's — — At any point in a magnetic field, or a conductor conveying current, the energy moves perpendicularly to the plane containing the lines of electric force or the lines of magnetic force, and the amount of energy crossing the unit of area of this plane per second is equal to the product of the intensities of the two forces multiplied by the sine of the angle between them, divided by 4π .

If E , represents the electric force of a small body charged with positive electricity, and H , the magnetic force or forces of a smaller free unit north pole, and, if these forces at any point in the magnetic field are inclined at an angle, θ , then e , the flow of energy per second at this point, in a direction perpendicular to the planes of E and H is,

$$e = \frac{E H \sin. \theta}{4 \pi}.$$

There is, therefore, a difference in the direction of the flow of electricity and the flow of electric energy. Electricity may be conceived as passing through the conductor something like water through a pipe, but electrical energy does not travel in this way. Electrical energy travels through the surrounding dielectric, which is thereby strained, and it propagates this strain from point to point until it reaches the conductor and is there dissipated.

Law, Voltametric — — The chemical action produced by electrolysis in any electrolyte is proportional to the amount of electricity which passes through the electrolyte.

This is called the Voltametric law, because any vessel containing an electrolyte, and furnished with electrodes, so that electrolysis may take place on the passage of the current, and is provided with means for measuring the amount of the electrolysis which occurs, is called a Voltameter. (See *Voltameter. Electrolysis.*)

Laws, Ampère's, or Laws of Electro-Dynamic Attraction and Repulsion — — Laws expressing the attractions and repulsions of electric circuits on one another or on magnets.

Laws, Dub's — — "The magnetism excited at any transverse section of a magnet is proportional to the square root of the distance between the given section and the near end of the magnet."

"The free magnetism at any given transverse section of a magnet is proportional to the difference between the square root of half the length of the magnet and the square root of the distance between the given section and the nearest end."

Laws, Kirchoff's — — The laws for branched or shunted circuits.

These laws may be expressed as follows:

(1.) In any number of conductors meeting at a point, if currents flowing to the point be considered as +, and those flowing away from it as —, the algebraic sum of the meeting currents will be zero.

This is the same thing as saying as much electricity must flow away from the point as flows toward it.

(2.) In any system of closed circuits the algebraic sum of the products of the currents into the resistances is equal to the electromotive force in the circuit.

In this case all currents flowing in a certain direction are taken as positive, and those flowing in the opposite direction as negative. All electromotive forces tending to produce currents in the direction of the positive current are taken as positive, and those tending to produce currents in the opposite direction, as negative.

This follows from Ohm's law; for, since $C = \frac{E}{R}$, the electromotive force $E = CR$, and this is true, no matter how often the circuit is branched.

Laws, Lenz's — — Laws for determining the directions of currents produced by electrodynamic induction.

The direction of the currents set up by electrodynamic induction is always such as to oppose the notions by which such currents were produced.

Laws of Becquerel, or Laws of Magneto-Optic Rotation. — Laws for the magneto-optic rotation of the plane of polarization of light. (See *Rotation, Magneto-Optic.*)

Laws of Coulomb, or Laws of Electro-

static and Magnetic Attractions and Repulsions.—Laws for the force of attraction and repulsion between charged bodies or between magnet poles.

The fact that the force of electrostatic attraction or repulsion between two charges, is directly proportional to the product of the quantities of electricity of the two charges and inversely proportional to the square of the distance between them, is known as *Coulomb's Law*. Coulomb also ascertained that the attractions and repulsions between magnet poles are directly proportional to the product of the strength of the two poles, and inversely proportional to the square of the distance between them. This is also called Coulomb's Law.

Coulomb's law, in order to be accurate, must take into account the specific inductive capacity of the intervening medium. The correct expression for the force between two quantities q and q' , of electricity would be, therefore,

$$F = \frac{q q'}{r^2 K},$$

where K , is equal to the specific inductive capacity of the medium separating the two charges.

In a similar manner when the force is exerted between two magnet poles, to be accurate, we must take into account the magnetic permeability of the medium between the two magnets. The correct expression for the force between two magnet poles is, therefore,

$$F = \frac{m m'}{r^2 \mu},$$

when μ , is the magnetic permeability.

Laws of Faraday, or Laws of Electrolysis

—Laws for the effects of electrolytic decomposition. (See *Electrolysis*.)

These laws are as follows:

(1.) The amount of an electrolyte decomposed is directly proportional to the quantity of electricity which passes through it; or, the rate at which a body is electrolyzed is proportional to the current strength producing such electrolysis.

(2.) If the same current be passed through different electrolytes, the quantity of each ion evolved is proportional to its chemical equivalent.

Laws of Joule.—Laws expressing the development of heat produced in a circuit by an electric current.

These laws may be expressed as follows:

(1.) The amount of heat developed in any cir-

cuit is proportional to its resistance, providing the current strength is constant.

(2.) The amount of heat developed in any circuit is proportional to the square of the current passing, providing the resistance is constant.

(3.) The amount of heat developed in any circuit is proportional to the time the current continues.

$$\text{Or, } H = C^2 R t \times 0.24.$$

Where H , equals the heat in small calories, C , equals the current in ampères, R equals the resistance in ohms, t , equals the time in seconds, and 0.24, the heat-units per second developed in a resistance of 1 ohm by the passage of 1 ampère.

Lay Torpedo.—(See *Torpedo, Lay*.)

Layer, Crookes' ——A layer, or stratum, of the residual atmosphere of a vacuum space, in which the molecules, recoiling from a heated or electrified surface, do not meet other molecules, but impinge on the walls of the vessel directly opposite such heated or electrified surface.

A Crookes layer may result as the effect of two different causes, viz.:

(1.) The rarefaction of the gas is such that the distance between the walls of the vessel and the heated surface is less than the mean-free-path of the molecules.

(2.) The wall is so near the heated surface that the distance between the two is less than the actual mean-free-path of the molecules. Under these last-named circumstances Crookes' layers may result, whatever be the density of the gas.

Laying-Up Cables.—(See *Cables, Laying-Up*.)

Lead, Angle of ——The angular deviation from the normal position, which must be given to the collecting brushes on the commutator cylinder of a dynamo-electric machine, in order to avoid destructive burning. (See *Commutator, Burning at*.)

The necessity for giving the collecting brushes a lead, arises both from the magnetic lag and from the distortion of the field of the machine by the magnetization of the armature current. The angle of lead is, therefore, equal to the sum of the angle of lag, and the angular distortion due to the magnetization produced by the armature current.

Lead, Cable — —A lead containing a conductor formed of several stranded conductors, as distinguished from a wire lead or a lead containing a single conductor.

Lead, Flexible — —A conductor formed of a number of small stranded conductors for the purpose of obtaining flexibility.

Lead, Flexible Twin — —A flexible conductor in which two parallel and separately insulated wires are placed.

Lead of Brushes of Dynamo-Electric Machine.—The angular deviation from the normal position, which it is necessary to give the brushes on the commutator of a dynamo-electric machine, in order to obtain efficient action. (See *Lead, Angle of.*)

Lead Scoring Tool.—(See *Tool, Scoring, Lead.*)

Lead Sleeve.—(See *Sleeve, Lead.*)

Lead, Tee.—(See *Tee, Lead.*)

Lead, Wire — —A lead consisting of a single conductor, as distinguished from a cable lead, or a lead containing a number of stranded conductors.

Lead Wire.—(See *Wire, Lead.*)

Leading Horn of Pole Pieces of Dynamo-Electric Machine.—(See *Horns, Leading, of Pole Pieces of a Dynamo-Electric Machine.*)

Leading-In Wires.—(See *Wires, Leading-In.*)

Leading-Up Wires.—(See *Wires, Leading-Up.*)

Leads.—The conductors in any system of electric distribution.

In distribution by parallel, the conductors through which the current flows from the source are sometimes called the leads in contradistinction to those through which it returns to the source.

The leads, or main conductors, in a multiple system of electric lighting, must maintain a constant potential at the lamp terminals. The dimensions of the leads are, therefore, so proportioned as to absorb as small an amount of potential as possible. Since, in incandescent lighting, where the lamps are connected to the leads in multiple-arc, the total resistance of the lamps is comparatively

small, the resistance of the leads must be quite small in order to avoid a marked drop of potential. Comparatively large conductors must, therefore, be used.

The main conductor for series circuits, such as for arc-lights, has in all parts the same current strength. Since the sum of the resistances of the lamps in such a circuit is quite high, a comparatively high resistance in the conductor may be employed without a proportionally large absorption of potential. Comparatively small conductors can therefore be used. (See *Electricity, Distribution of, by Constant Currents. Electricity, Distribution of, by Alternating Currents.*)

Leads, Armature, Twist in — —A displacement of the ends of the wires connected to the commutator segment, with respect to the position of the coils on the armature, for the purpose of obtaining a more convenient position for the diameter of commutation, that is, for the collecting brushes.

Leak, Oscillatory — —A leak or gradual loss of electricity which takes place in alternately opposite directions.

Leak, Unidirectional — —A gradual loss or leakage of electricity which takes place in one and the same direction.

The term has been employed to distinguish such a leak from an oscillatory leak.

Leakage Conductor.—(See *Conductor, Leakage.*)

Leakage, Electric — —The gradual dissipation of a current due to insufficient insulation.

Some leakage occurs under nearly all circumstances. On telegraphic lines, during wet weather, the leakage is often so great as to interfere with the proper working of the lines.

Leakage, Electrostatic — —The gradual dissipation of a charge due to insufficient insulation.

The leakage of a well insulated conductor, placed in a high vacuum, is almost inappreciable. Crookes has maintained electric charges in high vacua for years without appreciable loss.

Leakage, Lateral, of Lines of Magnetic Force — —The failure of lines of magnetic

force to pass approximately parallel to one another through a bar of iron or other magnetizable material, when it has come to rest in a magnetic field in which it is free to move.

The escape of the lines of magnetic force from the sides of a bar or other similar magnet, instead of from the poles at the end.

When a bar of magnetizable material, suspended so as to be free to move, comes to rest in a magnetic field in which it is undergoing magnetization, it has its greatest length parallel to the direction of the lines of force. If the bar is a long, thin, straight bar, the lines of force do not all pass in or come out at its ends. On the contrary, many of these lines of force or induction pass in or come out at other points. The magnetic induction is, therefore, unequal at different sections of the bar. In other words, the magnetic flux or intensity is not constant per unit of all cross-sections of such bar.

Leakage, Magnetic — — A useless dissipation of the lines of magnetic force of a dynamo-electric machine, or other similar device, by their failure to pass through the armature where they are needed.

Useless dissipation of lines of magnetic force outside that portion of the field of a dynamo-electric machine through which the armature moves.

Such a leakage can be detected by an instrument called a *magnetophone*. (See *Magnetophone*.)

Magnetic leakage results in lowering the efficiency of the dynamo. (See *Co-efficient, Economic, of a Dynamo-Electric Machine*.)

Leclanché's Voltaic Cell.—(See *Cell, Voltaic, Leclanché*.)

Leg.—In a system of telephonic exchange, where a ground return is used, a single wire, or, where a metallic circuit is employed, two wires, for connecting a subscriber with the main switchboard, by means of which any subscriber may be legged or placed directly in circuit with two or more other parties.

Leg of Circuit.—(See *Circuit, Leg of*.)

Legal Earth Quadrant.—(See *Quadrant, Legal Earth*.)

Legal Ohm.—(See *Ohm, Legal*.)

Legging-Key Board.—(See *Board, Legging-Key*.)

Length of Spark.—(See *Spark, Length of*.)

Lens, Achromatic — — A lens the images formed by which are free from the false coloration produced in other lenses by dispersion.

An ordinary lens can be rendered approximately achromatic by the use of a diaphragm. Achromatic lenses generally consist of the com-

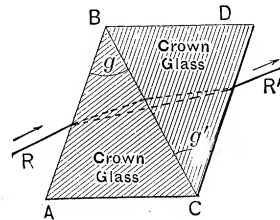

Fig. 342. Equal and Opposite Refracting Angles.

bination of a double convex lens of flint glass and a concave lens of crown glass.

The ray of light entering the prism A B C, Fig. 342, suffers dispersion (separation into prismatic colors). This dispersion in the same

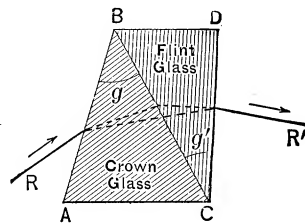

Fig. 343. Principle of Achromatism.

medium is proportional to the angle g , between the incident and emergent faces, called the *refracting angle*.

If, now, another prism B C D, of the same material, with a refracting angle g' , equal to g , is combined with the first prism in the manner shown in Fig. 342, it will produce an equal but opposite dispersion, so that the ray of light will emerge at R' , free from rainbow tints, but parallel to its original direction.

The variety of glass called *crown glass* produces only half as great dispersion of light as the variety called *flint glass*, under the same refract-

ing angle g . If the prism $A B C$, of crown glass, Fig. 343, whose angle g , is twice as great as the refracting angle g' , of the prism $B C D$, of flint glass, be placed together in the manner shown, then the ray R , will be transmitted at R' , free from color, *but will not emerge parallel to its original direction*; in other words, it suffers refraction or bending. Consequently such a combination can be used to free a pencil of light from false coloration and yet permit it to undergo refraction, and thus act as a lens. (See *Refraction*.)

The construction of achromatic lenses is based on this principle.

The crown glass is generally made with two

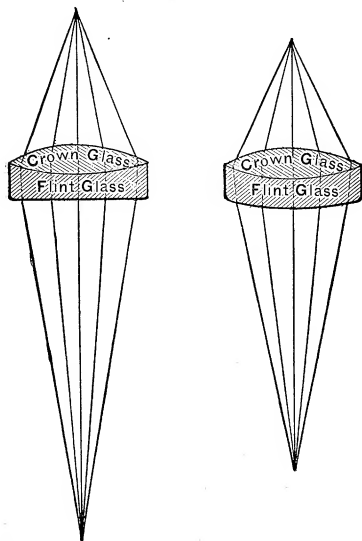

Fig. 344. Plano-Convex Achromatic Lens. Fig. 345. Achromatic Lens.

convex surfaces; the flint glass, with one concave and one plane surface, as shown in Fig. 344.

Sometimes both surfaces of the flint glass are made curved, as in Fig. 345.

Lenz's Law.—(See *Law, Lenz's*.)

Letter Box, Electric — —A device that announces the deposit of a letter in a box by the ringing of a bell, or by the movement of a needle or index.

These devices generally act by the closing or opening of an electric circuit on the fall of the letter into the box.

Leyden Jar.—(See *Jar, Leyden*.)

Leyden Jar Pattery.—(See *Battery, Leyden Jar*.)

Lichtenberg's Dust Figures.—(See *Figures, Lichtenberg's Dust*.)

Life Curve of Incandescent Electric Lamp.—(See *Curve, Life, of Incandescent Electric Lamp*.)

Life of Electric Incandescent Lamp.—(See *Lamp, Incandescent, Life of*.)

Light, Auroral — —The light given off during the prevalence of an aurora. (See *Aurora Borealis*.)

Light, Electric — —Light produced by the action of electric energy.

Electric light is produced by electric energy in various ways, the most important of which are as follows, viz.:

(1.) By the passage of an electric discharge through a gas or vapor, either in a rarefied condition, at ordinary atmospheric pressure, or at pressures higher than that of the ordinary pressure. In any of these cases the gas or vapor is heated to incandescence by the passage of the discharge.

(2.) By the incandescence of a solid by the heating power of the current, as in the incandescent lamp.

(3.) By the incandescence of a solid by the action of a rapidly alternating electrostatic field, as in Tesla's incandescent lamp.

(4.) By the volatilization of a solid and the formation thereby of a voltaic arc.

(5.) By the combination of the effects of incandescence and the voltaic arc.

The amount of light produced in proportion to the amount of energy expended to produce it is probably least in the case of light produced by the sparks of a Wimshurst or Holtz machine, or as in (1), than in any other case in which electric energy acts to produce luminous energy.

Light, Electric, Pumping of — —(See *Pumping of Electric Light*.)

Light, Intensity of — —The brilliancy or illuminating power of a light as measured by a photometer in standard candles or other standard units. (See *Photometer, Candle, Standard*.)

Light, Maxwell's Electro - Magnetic Theory of — —A hypothesis for the

cause of light proposed by Maxwell, based on the relations existing between the phenomena of light and those of electro-magnetism.

Maxwell's electro-magnetic theory of light assumes that the phenomena of light and magnetism are each due to certain motions of the ether, electricity and magnetism being due to its rotations, and light to oscillations, or its to-and-fro motions.

Maxwell proposed this theory to show that the phenomena of light, heat, electricity and magnetism could all be explained by one and the same cause, viz., a vibratory or oscillatory motion of the particles of the hypothetical ether. Maxwell died before completing his hypothesis, and it has never since been sufficiently developed to thoroughly entitle it to the name of a theory. This theory has more recently been elaborated by Hertz. (See *Electricity, Hertz's Theory of Electro-Magnetic Radiations or Waves.*)

There are, however, numerous considerations which render it probable that electric and magnetic phenomena, like those of light and heat, have their origin in a vibratory or oscillatory motion of the luminiferous ether. A few of these, as pointed out by Maxwell, S. P. Thompson, Lodge, Larden and others, are as follows:

(1.) It is possible that the thing called electricity is the ether itself, negative electrification consisting in an *excess* of the ether, and positive electrification in a *deficit*. (See *Electricity, Single-Fluid Hypothesis of.*)

(2.) It is possible that electrostatic phenomena consist in a *strain* or *deformation* of the ether. A *dielectric* may differ from a conductor in that the former may have such an attraction for the ether as to give it the properties of an elastic solid, while in the latter the ether is so free to move that no strain can possibly be retained by it. (See *Dielectric. Conductor.*)

(3.) Dielectrics are transparent and conductors are opaque.

There are exceptions to this in the case of vulcanite and many other excellent dielectrics. Nor should this similarity be expected to be general in view of the well known differences that exist between diathermancy and transparency.

(4.) It is possible that an electric current consists of a real motion of translation of the ether through a conductor.

(5.) It is possible that electromotive force re-

sults from differences of *ether pressures*. This would of course follow from (4).

(6.) The vibrations of light are propagated in a direction at right angles to the direction in which the light is moving. The magnetic field of a current is propagated in planes at right angles to the direction in which the current is flowing.

(7.) It is possible that lines of electrostatic and magnetic force consist of chains of polarized ether particles.

(8.) The velocity of propagation of light agrees very nearly with the velocity of propagation of electro-magnetic induction. (See *Ratio Velocity.*)

(9.) In certain axial crystals the difference of transparency in the direction of certain axes, corresponds with the direction in which such crystals conduct electricity.

Recent investigations render it almost certain that light and electro-magnetic waves or radiations are one and the same, and, therefore, have the same velocity of propagation through free ether. Through fixed ether, that is, through the ether that exists between the molecules of different kinds of matter, as is well known, the velocity of propagation differs with different substances. (See *Electricity, Hertz's Theory of Electro-Magnetic Radiations or Waves.*)

Light, Northern — —(See *Aurora Borealis.*)

Light, Platinum-Standard — —The light emitted by a surface of platinum one square centimetre in area, at its temperature of fusion.

This is called the Violle Standard and is extensively used in France.

Light, Search, Automatic — —A search light in which a parallel or slightly diverging beam of light is automatically caused to sweep the horizon, and thus disclose the approach of a torpedo boat or other similar danger.

This is called an automatic search light because it may be caused to automatically sweep the horizon, instead of being manipulated by hand, as usual.

Light, Search, Electric — —An electric arc light placed in a focusing lamp before a lens or mirror, so as to obtain either a parallel beam or a slightly divergent pencil of light

for lighting the surrounding space for purposes of exploration.

Light, Southern — —(See *Aurora Australis*.)

Light, Tail — —A light displayed at the rear end of trains in order to avoid rear collisions. (See *Railroads, Block System for*.)

Lighter, Cigar, Electric — —An apparatus for electrically lighting a cigar.

A cigar lighter consists essentially of a wire or rod of refractory substance, rendered incandescent by the passage of a current obtained from a voltaic battery, secondary generator, or other electric source.

Lighter, Electric, Argand — —A name sometimes given to an argand electric plain-pendant burner. (See *Burner, Argand-Electric, Plain-Pendant*.)

Lighter, Electric, Argand Valve — —A name sometimes given to an argand electric ratchet-pendant burner. (See *Burner, Argand-Electric, Ratchet-Pendant*.)

Lighthouse Illumination, Electric — —(See *Illumination, Lighthouse, Electric*.)

Lighting, Arc — —Artificial illumination obtained by means of an arc light.

The term arc lighting is used in contradistinction to incandescent lighting. In the United States, and, indeed, generally, a number of arc lights are placed in series on the line circuit, connected generally with a series dynamo. Each of the lamps is provided with a safety cut-out, which cuts out or removes a defective lamp from the circuit by automatically turning or switching the current through a shunt of low resistance.

Lighting, Electric, by High Frequency Currents — —A system of electric lighting, in which rods, bars or filaments of carbon or other refractory substances are raised to incandescence when placed in a rapidly alternating electrostatic field.

This system of electric lighting was invented by Nikola Tesla. Its general principles will be understood from an inspection of Fig. 346.

G, is a dynamo producing alternating currents of comparatively low potential. A portion of its current P, acting as the primary of an induction coil, induces alternating currents of high

potential in the secondary circuit S, which, charging the condenser C, is disruptively discharged into the circuit A, provided with an air gap at A' through P'. The inductive action of P', on S', produces oscillatory currents of

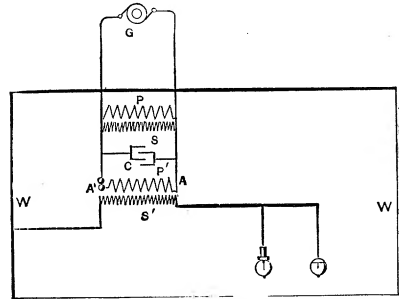

Fig. 346. Tesla's High Frequency Currents System of Lighting.

enormous frequency and potential in the secondary circuits connected therewith. In the apparatus shown in Fig. 346, two incandescent electric lamps are connected with the secondary circuit, one with a single straight filament, and the other with a ball conductor. The other terminal of S', is connected to the walls of the room to be lighted. (See *Lamp, Incandescent, Straight Filament. Lamp, Electric, Incandescent Ball*.)

Lighting, Electric, Central Station — —The lighting of a number of houses or other buildings from a single station, centrally located.

Central station lighting is distinguished from isolated lighting by the fact that a number of separate buildings, houses or areas, are lighted by the current produced at a single station, centrally located, instead of from a number of separate electric sources located in each of the houses, etc., to be lighted. (See *Electricity, Distribution of*.)

Lighting, Electric Gas — —Igniting gas jets by means of electric discharges.

Electric sparks are caused to pass through a jet of escaping gas, and thus to light it. These sparks are obtained from a spark-coil, *i. e.*, a coil of insulated wire connected in series with the circuit so as to produce an extra current on the sudden breaking of the circuit, the discharge of which produces a spark capable of igniting the gas. In cases where a number of burners are to be simultaneously lighted the sparks required for

lighting the gas are obtained from the secondary of an induction coil. (See *Burner, Automatic Electric.*)

Lighting, Electric, Isolated — —A system of electric lighting where a separate electric source is placed in each house or area to be lighted, as distinguished from the central station lighting, where electric sources are provided for the production of the current required for an entire neighborhood.

Lighting, Electric, Long-Arc System of — —A system of electric lighting in which long arcs are maintained between the carbon electrodes.

Lighting, Electric, Short-Arc System — —A system of electric lighting in which short voltaic arcs are maintained between the carbon electrodes.

Systems of short arcs require an electromotive force of about 25 volts, which is about one-half that employed in long arcs. To develop an equal amount of heat energy in a short arc as in a long arc, therefore, requires that the current be of double strength.

The greater part of the light of a voltaic arc is given off from a tiny crater, which is formed in the end of the positive carbon. In the short-arc system the crater lies so near the negative carbon that much of its light is necessarily obscured, and troublesome shadows are sometimes produced. The long-arc system avoids these difficulties.

Lightning.—The spark or bolt that results from the disruptive discharge of a cloud to the earth, or to a neighboring cloud. (See *Electricity, Atmospheric. Kite, Franklin's.*)

Lightning Arrester.—(See *Arrester, Lightning.*)

Lightning, Back-Stroke of — —An electric discharge, caused by an induced charge, which occurs after the direct discharge of a lightning flash.

The shock is not caused by the lightning flash itself, but most probably by a charge which is induced in neighboring conductors by the discharge. A similar effect may be noticed by standing near the conductor of a powerful electric machine, when shocks are felt at every discharge.

The back-stroke has been ascribed by many to

the oscillations by which a disruptive discharge is effected. (See *Discharge, Oscillating.*)

The effects of the return shock are sometimes quite severe. They are often experienced by sensitive people, on the occurrence of a lightning discharge, at a considerable distance from the place where the discharge occurred.

In some instances, the return stroke has been sufficiently intense to cause death. In general, however, its effects are much less severe than those of the direct lightning discharge.

Lightning, Ball — —A name sometimes given to globular lightning. (See *Lightning, Globular.*)

Lightning, Chain — —A variety of lightning flash in which the discharge takes a rippling path, somewhat resembling a chain.

Lightning Conductor.—(See *Rod, Lightning.*)

Lightning, Forked — —A variety of lightning flash, in which the discharge, on nearing the earth or other object, divides into two or more branches.

Lightning, Globular — —A rare form of lightning, in which a globe of fire appears, which quietly floats for a while in the air, and then explodes with great violence.

The exact cause of globular lightning is unknown. Phenomena allied to it, however, have been observed by Planté during the series discharge of his rheostatic machine. Similar phenomena are sometimes, though rarely, observed during the discharge of a powerful Leyden battery. Sir Wm. Thomson ascribes the effect to an optical illusion due to the persistence of the visual impression of a bright flash. This, however, would not account for the explosion which almost invariably attends globular lightning.

Lightning Guard.—(See *Guard, Lightning.*)

Lightning, Heat — —A variety of lightning flash in which the discharge lights up the surfaces of the neighboring clouds.

Sheet lightning is unaccompanied by thunder. It may be regarded as a brush discharge from one cloud to another.

Heat lightning is a variety of sheet lightning. (See *Lightning, Sheet.*)

Lightning Jar.—(See *Jar, Lightning*.)

Lightning, Return-Stroke of —A term sometimes applied to the back-stroke of lightning. (See *Lightning, Back-Stroke of*.)

Lightning Rod.—(See *Rod, Lightning*.)

Lightning Rod for Ships.—(See *Rod, Lightning, for Ships*.)

Lightning, Sheet —A variety of lightning flash unaccompanied by any thunder audible to the observer, in which the entire surfaces of the clouds are illumined.

The cause of sheet lightning has been ascribed to reflection from clouds of lightning flashes that occur too far below the horizon either to permit them to be directly seen, or the thunder to be heard.

If a Geissler tube, which contains several concentric tubes, be charged by a Holtz machine, and then touched at different parts by the hands, a succession of luminous discharges will be seen in the dark, that bear a remarkable resemblance to the flashes of heat or sheet lightning.

Lightning Stroke.—(See *Stroke, Lightning*.)

Lightning Stroke, Back or Return —
—(See *Stroke, Lightning, Back or Return*.)

Lightning, Summer —A name sometimes given to heat lightning. (See *Lightning, Heat*.)

Lightning, Volcanic —The lightning discharges that attend most volcanic eruptions.

Volcanic lightning is possibly sometimes due to the friction of volcanic dust particles against one another, or against the air, but is more probably caused by the sudden condensation of the water vapor that is generally disengaged during volcanic eruptions.

Lightning, Zigzag —The commonest variety of lightning flashes, in which the discharge apparently assumes a forked zigzag, or even a chain-shaped path.

This form is seen in the discharge of a Holtz machine, or of a *Ruhmkorff Induction Coil*.

Photographic pictures of such lightning discharges appear to show that these discharges are in reality zigzag curves, rather than sharp angular zigzags.

Limiting Stop.—(See *Stop, Limiting*.)

Limb, Rheoscopic —A term sometimes applied to a sensitive nerve muscle preparation, employed to detect the presence of an electric current. (See *Frog, Galvanoscope*.)

Line.—A wire or other conductor connecting any two points or stations.

Line, Aclinic —A line connecting places on the earth's surface which have no magnetic inclination.

The magnetic equator of the earth. (See *Equator, Magnetic*.)

Line Adjuster.—An instrument invented by Delany for overcoming the effects of leakage on the adjustment of the relays in a way line.

When any key is opened, the line circuit is simultaneously broken at both ends so that there is a moment of no current, which causes all the relays to respond.

Line, Aerial —An air line as distinguished from an underground conductor.

Line, Agonic —A line connecting places on the earth's surface where the magnetic needle has no declination, or where it points to the true geographical north. (See *Agonic*.)

Line, Artificial —A line so made up by condensers and resistance coils as to have the same inductive effects on charging or discharging as an actual telegraph line.

In duplex telegraphy by the differential method, the artificial line used must have its capacity balanced against that of the line, so as to avoid the effects of self-induction, and other effects produced by charging and discharging.

Line, Capacity of —The ability of a line or cable to act like a condenser, and therefore like it to possess a capacity. (See *Cable, Capacity of*.)

Line Circuit.—(See *Circuit, Line*.)

Line Circuit, Telegraphic —(See *Circuit, Line, Telegraphic*.)

Line, Neutral, of a Magnet —A line joining the neutral points of a magnet or

points approximately midway between the poles.

This is sometimes called the equator of the magnet.

The neutral point is the point where the lines of force outside the magnet extend parallel to the surface of the magnet.—(*Hering.*)

Line, Neutral, of Commutator Cylinder

—A line on the commutator cylinder of a dynamo-electric machine connecting the neutral points, or the points of maximum positive and negative difference of potential. (See *Machine, Dynamo-Electric.*)

Line of Least Sparking.—(See *Sparking, Least Line of.*)

Line, Single-Wire —A term sometimes used for a solid-wire conductor. (See *Line, Solid.*)

Line, Solid —A line formed of a single conductor, as distinguished from a line formed of several conductors or by a stranded cable.

Line, Stranded —A line formed of several strands or separate conductors twisted into one.

Line, Telegraphic, Telephonic, etc. —The conducting circuit provided for the transmission of the electric impulses or currents employed in any system of electric transmission.

Line, Telfer —The conducting line used in a system of telferage. (See *Telferage.*)

Line, Through —A line extending between two terminal points, as distinguished from a line containing way stations.

Line, Trunk —In a system of telephonic communication any line connecting distant stations and used by a number of subscribers at each end for purposes of intercommunication.

Line, Way —A line communicating with way stations.

Line Wire.—(See *Wire, Line.*)

Lineman.—One who puts up and repairs line circuits and attends to the devices connected therewith.

In a system of electric lighting the lineman attends to carboning the lamps, cleaning the lamp rods, and, generally, to the minor details of the lines, insulators and the electro-receptive devices placed on the line.

Lines, Halleyan —A term sometimes applied to the isogonal lines.

The isogonal lines are sometimes called the Halleyan lines, from Halley, who published the first chart of such lines in the year 1701.

Lines, Isobaric —Lines connecting places on the earth's surface which simultaneously have the same barometric pressure.

The isobaric lines are sometimes called isobars.

Lines, Isoclinic —Lines connecting places that have the same angle of magnetic dip or inclination. (See *Dip, Magnetic.*)

Lines, Isodynamic —Lines connecting places which have the same total magnetic intensity.

The magnetic intensity of a place is determined by the number of oscillations that a small magnetic needle, moved from its position of rest in the magnetic meridian of any place, makes in a given time. This method is similar to that employed for determining the intensity of gravity at any place by observing the number of oscillations that a pendulum of a given length makes in a given time at that place. If, for example, a magnetic needle at one place makes 211 oscillations in ten minutes, and 245 in the same time at another place, then the relative intensities of magnetism at these places are as the squares of those numbers, or as 44,521 : 60,025, or as 1 : 1.348.

Lines, Isogonal —Lines connecting places that have the same magnetic declination. (See *Declination.*)

Lines, Isogonic —A term sometimes used for isogonal lines. (See *Lines, Isogonic.*)

Lines, Isothermal —Lines connecting points or places which have the same mean temperature.

Lines, Kapp —A term proposed by Mr. Gisbert Kapp for a unit of lines of magnetic force.

One Kapp line = 6,000 C. G. S. magnetic lines.

Since there are 6.4514 square centimetres in a square inch, 1 Kapp line per square inch = $\frac{6,000}{6.4514} = 930$ C. G. S. lines per square cm.

The total number of Kapp lines passing through a magnet and air space is equal to the ampère turns divided by the total magnetic reluctance in the magnetic circuit.—(*Urquhart.*)

Lines of Electric Displacement.—(See *Displacement, Electric, Lines of.*)

Lines of Electrostatic Force.—(See *Force, Electrostatic, Lines of.*)

Lines of Force, Cutting — —(See *Force, Lines of, Cutting.*)

Lines of Force, Direction of — —(See *Force, Lines of, Direction of.*)

Lines of Inductive Action.—(See *Action, Inductive, Lines of.*)

Lines of Magnetic Force.—(See *Force, Magnetic, Lines of.*)

Lines of Magnetic Force, Conducting Power for — —(See *Force, Magnetic, Lines of, Conducting Power for.*)

Lines of Magnetic Induction.—(See *Induction, Magnetic, Lines of.*)

Lines, Overhead — —A term applied to telegraph, telephone and electric light or power lines that run overhead, in contradistinction to similar lines placed underground.

Lines, Vortex-Stream — —Lines extending in the direction in which the particles of a fluid are moving.

A vortex stream is supposed to be composed of a number of vortex-stream lines.

Linked Magnetic and Electric Chain.—(See *Chain, Linked Magnetic and Electric.*)

Links, Fuse — —Strips or plates of fusible metal in the form of links, employed for safety fuses for incandescent or other circuits.

Liquid, Bright Dipping — —A liquid used in electro-plating for dipping articles preparatory to electro-plating, so as to insure a bright plating deposit on them when afterwards subjected to the plating process.

A bright dipping liquid is prepared by the addition of 1 volume of common table salt to a mixture of 100 volumes each of sulphuric and nitric acids. For small objects or articles of copper, or other readily corroded metals, the

above solution is diluted by the addition of one-eighth its volume of water.

Liquid, Electropon — —A battery liquid consisting of 1 pound of bichromate of potash dissolved in 10 pounds of water, to which 2½ pounds of commercial sulphuric acid has been gradually added.

This liquid is employed with the carbon-zinc cell or the bichromate of potash cell.

Liquid, Exciting, of Voltaic Cell — —The electrolyte or liquid in a voltaic cell, which acts on the positive plate.

Liquid Level Alarm.—(See *Alarm, Water or Liquid Level.*)

Liquid Resistance Load.—(See *Load, Liquid Resistance.*)

Liquid, Stripping — —A liquid employed to remove a coating of one metal from the surface of another, without affecting the other metal.

The character of the stripping liquid used will depend on the kind of metal to be removed, and whether the stripping is to be accomplished by solution effected by chemical action, or by electrolytic action.

Liquid, Specific Resistance of — —(See *Resistance, Specific, of Liquid.*)

Liquor, Spent — —Any liquor, such as that in the acid or other baths used in electro-plating, that has become weakened by use.

Listening Cam.—(See *Cam, Listening.*)

Load, Liquid Resistance — —An artificial load for a dynamo-electric machine, consisting of a mass of liquid interposed between electrodes.

A liquid is generally rendered better conducting by the addition of a small quantity of soluble salt, such, for example, as sulphate of soda.

Local Action of Dynamo-Electric Machine.—(See *Action, Local, of Dynamo-Electric Machine.*)

Local Action of Voltaic Cell.—(See *Action, Local, of Voltaic Cell.*)

Local Battery.—(See *Battery, Local.*)

Local Battery Circuit.—(See *Circuit, Local-Battery.*)

Local Currents.—(See *Currents, Local*.)

Local Faradization.—(See *Faradization, Local*.)

Local Galvanization.—(See *Galvanization, Local*.)

Localization of Faults.—(See *Faults, Localization of*.)

Lock, Electric — —A lock that is automatically unlocked by the aid of electricity.

The electric lock is so arranged that the action of a push button at a distance unlocks the door. A speaking tube communicates with the house, and the pressing of a push button on any floor of the house unlocks the door. The mere shutting of the door locks it.

A form of electric lock is shown in Fig. 347.

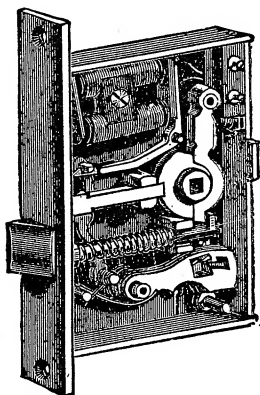

Fig. 347. Electric Lock.

Locomotive, Electric — —A railway engine whose motive power is electricity. (See *Railroads, Electric*.)

Locomotive Head Light, Electric — — (See *Head Light, Locomotive*.)

Lodestone.—A name formerly applied to an ore of iron (magnetic iron ore), that naturally possesses the power of attracting pieces of iron to it.

Lodestone, or magnetic iron ore, must be regarded as a magnetizable substance that has become permanently magnetic from its situation in the earth's magnetic field. Such beds of ore concentrate the lines of the earth's magnetic field on them, and thus become magnetic.

Lodge's Standard Voltaic Cell. —(See *Cell, Voltaic, Standard, Lodge's*.)

Log, Electric — —An electric device for measuring the speed of a vessel.

A log, operated by the rotation of a wheel, is caused to register the number of its rotations by a step-by-step recording apparatus operated by breaks in the circuit, made during the rotation of the wheel, at any given number of turns, say 100, or some other convenient multiple. Such a log may be kept constantly in the water, and observed when required, or it can be caused to make a permanent record of its actual speed at any time during the entire run.

Logarithm.—The exponent of the power to which it is necessary to raise a fixed number, in order to produce a given number.

A table of logarithms enables the operations of multiplication, division, the raising of powers, and the extraction of roots, to be readily performed by simple addition, subtraction, multiplication or division, respectively. When thoroughly understood, logarithms greatly reduce the labor of mathematical calculations. For the manner in which they are used, the student is referred to any standard work on mathematics.

Logarithmic Curve.—(See *Curve, Logarithmic*.)

Long-Coil Magnet.—(See *Magnet, Long-Coil*.)

Long-Core Electro-Magnet.—(See *Magnet, Electro, Long-Core*.)

Long-Shunt Compound-Wound Dynamo-Electric Machine.—(See *Machine, Dynamo-Electric, Compound-Wound, Long-Shunt*.)

Longitude, Electric Determination of — —The determination of the longitude of a place, by differences in time between it and a place on the prime meridian, as simultaneously determined telegraphically.

In determinations of this character allowance must be made for the retarding effects of long telegraphic lines, or cables.

Loom, Electric — —A device by means of which Jacquard cards in the ordinary loom are replaced by a simple perforated metal plate, the perforations in which correspond to those in the Jacquard card.

The necessary movements are effected by means of electro-magnets.

Loop Break.—A device for introducing a loop in a break made at any part of a circuit.

The rigidity of the line wire, between the points of attachment of the loop introduced, is maintained by means of some inflexible non-conducting material inserted in the break.

Loop Circuit.—(See *Circuit, Loop*.)

Loop, Drip — — An inclined loop placed where the outside conductors enter a building.

The inclination is upwards towards the point of entrance to the building. This device of a drip loop is adopted for the purpose of preventing the rain water from flowing along the inclined wire into the building. This is effected by making the wire incline from the building, thus throwing the drainage from the building.

Loop, Electric — — A portion of a main circuit consisting of a wire going out from one side of a break in the main circuit and returning to the other side of the break.

Loops are employed for the purpose of connecting a branch telegraph office with the main line; for placing one or more electric arc lamps on the main line circuit; for connecting a *mes-senger call* or *telephone circuit* with a main line; and for numerous similar purposes.

Loops of Force.—(See *Forcé, Loops of*.)

Loops of Mutual Induction.—(See *Induction, Mutual, Loops of*.)

Low-Resistance Magnet.—(See *Magnet, Low-Resistance*.)

Low-Tension Electric Fuse.—(See *Fuse, Electric, Low-Tension*.)

Loxodrograph.—An apparatus for electrically recording on paper the actual course of a ship by the combined action of magnetism and photography.

Luces.—Plural of lux. (See *Lux*.)

Luminescence.—A limited power of emitting light, possessed by certain bodies which have previously acquired potential energy by exposure to light or radiant energy.

The term luminescence was proposed by E. Wiedemann to cover the case of the emission of

light under circumstances differing from the emission or radiation of light by incandescence. Luminescence applies to the case of a radiation, generally selective in character, that is apparently due to effects allied to, or the same as, those of fluorescence and phosphorescence. For example, magnesium oxide or zinc oxide, when heated above a certain critical temperature, radiates far more light than equally hot carbon.

The spectrum of such luminescent light is especially rich in certain wave lengths. The ability of the substance to continue to furnish this extra light is, however, limited. After a comparatively short time, the additional light, or selective radiation, disappears. The luminescent light is apparently due to molecular potential energy stored in the substance during its exposure to light. Luminescence may be developed in bodies in the following manner, viz.:

- (1.) By heat.
- (2.) By chemical action.
- (3.) By friction.
- (4.) By exposure to the sun, or by actual impact of light waves.
- (5.) By electricity.
- (6.) By vital forces, as in the fire fly, or the glow worm.

Luminescence, Rejuvenation of — — Reimparting by exposure to light, or any other suitable means, the power of luminescence to a substance after it has lost this power.

Luminous Absorption.—(See *Absorption, Luminous*.)

Lunar Inequality of Earth's Magnetic Variation or Inclination.—(See *Inequality, Lunar, of Earth's Magnetic Variation or Inclination*.)

Lunar Inequality of Earth's Magnetism.—(See *Inequality, Lunar, of Earth's Magnetism*.)

Lux.—A name proposed by Preece for the unit of intensity of illumination.

The illumination given by a standard candle at the distance of 12.7 inches.

The illumination given by 1 carcel at the distance of 1 metre.

The illumination given by a lamp of 10,000 candles at 105.8 feet. (See *Illumination, Unit of*.)

M

M.—A contraction sometimes used to express a gaseous pressure of the .000001 of an atmosphere.

1,000,000 M. equals 760 mm. of mercury or 1 atmosphere of pressure.

A vessel containing air, which has been exhausted to the .000001 of its pressure at 760 mm., or one atmosphere, has a pressure or tension of 1 M.

This contraction is used by Crookes in his researches on the properties of radiant matter. (See *Matter, Radiant, or Ultra Gaseous.*)

μ .—A contraction used in mathematical writings for magnetic permeability, or the specific conductivity of any substance for lines of magnetic force.

mm.—A contraction for millimetre. (See *Weights, French System of.*)

M. P. H.—A contraction sometimes used in railroad work to indicate miles per hour.

Machine, Armstrong's Hydro-Electric — — A machine for the development of electricity by the friction of a jet of steam passing over a water surface.

Steam generated in a suitably insulated boiler,

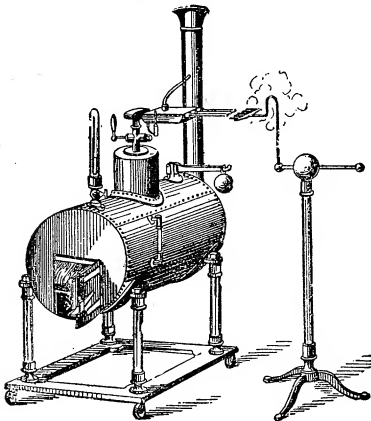

Fig. 348. Armstrong's Hydro-Electric Machine.

Fig. 348, is allowed to escape through a tortuous nozzle, from a series of apertures opposite a pointed comb, attached to an insulated conductor.

The cooling of the steam during its passage through a flat box, termed the *cooling box*, connected with the nozzles, causes a partial condensation, so that the box always contains a small quantity of water.

The friction of the drops of water against the orifice, and, possibly, their friction against the water surface itself, are the cause of the electricity produced.

A conductor connected with the pointed comb furnishes positive electricity. The boiler furnishes negative electricity. The hydro-electric machine is not a very economical source of electricity, and is only employed for experimental purposes. It was discovered accidentally through a shock given to an engineer, who placed his hand in a jet of steam escaping from a leaking boiler he was endeavoring to mend. The causes were first studied by Sir Wm. Armstrong, who, in 1840, devised the apparatus just described.

Machine, Dynamo-Electric — — A machine for the conversion of mechanical energy into electrical energy, by means of magneto-electric induction.

The term is also applied to a machine by means of which electrical energy is converted into mechanical energy by means of magneto-electric induction. Machines of the latter class are generally called *motors*, those of the former, *generators*.

Prof. S. P. Thompson defines a dynamo-electric machine as follows, viz.: "A machine for converting energy in the form of mechanical power into energy in the form of electric currents, or vice versa, by the operation of setting conductors (usually in the form of coils of copper wire) to rotate in a magnetic field, or by varying a magnetic field in the presence of conductors."

The term dynamo was first applied to such machines, because in the form in which this machine first appeared, viz.: the series-wound machine, it was self-exciting, or required no excitement other than what it received by the rotation of its armature in the field of its magnets, or, indeed, in the field of the earth. (See *Machine, Dynamo-Electric, Reaction Principle of.*)

A dynamo-electric generator, or a dynamo-elec-

tric machine proper, consists of the following parts, viz.:

(1.) The revolving portion, usually the *armature*, in which the electromotive force is developed, which produces the current.

It must be borne in mind that it is not current, but *difference of electric potential*, or *electromotive force*, that is developed by any electric source from which a current is obtained. For ease of reference, however, we will speak of an electric current as being generated by the armature, or by the source. No ambiguity will be introduced if the student bears the above in mind.

(2.) The *field magnets*, which produce the field in which the armature revolves.

(3.) *h: pole pieces*, or free terminals of the field magnets.

(4.) The *commutator*, by which the currents developed in the armature are caused to flow in one and the same direction. In alternating machines, and in some continuous current dynamos this part is called the *collector*, and does not rectify the currents.

(5.) The *collecting brushes*, that rest on the *commutator cylinder* and take off the current generated in the armature.

Machine, Dynamo-Electric, Alternating-Current — —A dynamo-electric machine in which alternating currents are produced.

The field magnets may be either permanent magnets or electro-magnets. When electro-magnets are used, their coils may be separately excited by another machine whose current is continuous; or, they may be excited by the commuted current of a separate coil on the armature; or, they may be partly excited by commuted currents and partly by commuted currents from a transformer, placed in the main circuit of the dynamo.

Machine, Dynamo-Electric, Armature of — —(See *Armature, Dynamo-Electric Machine*.)

Machine, Dynamo-Electric, Bed-Piece of — —The frame or base on which a dynamo is supported.

The bed-piece is sometimes called the dynamo frame or base.

Machine, Dynamo-Electric, Bi-Polar — —A dynamo-electric machine, the armature of which rotates in a field formed by two magnet poles, as distinguished from a ma-

chine the armature of which rotates in a field formed by more than two magnet poles.

A dynamo-electric machine whose armature rotates in the field formed by more than two poles is called a multi-polar machine. (See *Machine, Dynamo-Electric, Multi-Polar*.)

Machine, Dynamo-Electric, Carcass of — —A term sometimes used in place of the field magnet frame of a dynamo-electric machine. (See *Machine, Dynamo-Electric, Frame of*.)

The term, field magnet frame, would appear to be the preferable term. The term, however, is used in France, and is derived from the French word for skeleton.

Machine, Dynamo-Electric, Closed-Coil — —A dynamo-electric machine, the armature coils of which are grouped in sections, communicating with successive bars of a collector, so as to be connected continuously together in a closed circuit.

The Gramme dynamo and most continuous-current dynamos are closed-coil dynamos.

Machine, Dynamo-Electric, Closed-Coil Disc — —A closed-coil dynamo-electric machine, the armature core of which is disc-shaped.

Machine, Dynamo-Electric, Closed-Coil Drum — —A closed-coil dynamo-electric machine, the armature core of which is drum-shaped.

Machine, Dynamo-Electric, Closed-Coil Ring — —A closed-coil dynamo-electric machine, the armature core of which is ring-shaped.

Machine, Dynamo-Electric, Collectors — —(See *Collectors of Dynamo-Electric Machines*.)

Machine, Dynamo-Electric, Compound Winding of — —(See *Winding, Compound, of Dynamo-Electric Machine*.)

Machine, Dynamo-Electric, Compound-Wound — —Machines whose field magnets are excited by more than one circuit of coils, or by more than a single electric source.

The object of compound winding is to make

the dynamo self-regulating under changes in its working load. A shunt-wound dynamo renders both series and multiple circuits approximately constant as regards their working. Multiple circuits, however, require great constancy of potential, and for this purpose the compounding of the dynamos is necessary.

In the compound dynamo, the shunt coils are superposed on the series coils, or are used in connection with them. The shunt coils consist of a much greater number of convolutions of fine wire than the series coils, which are of coarse wire.

Separate excitation is sometimes compounded either with series or with shunt field magnet coils.

Compound dynamos are of two classes, viz.:

(1.) Those designed to produce a constant potential, and

(2.) Those designed to produce a constant current.

For Constant Potential :

In the long-shunt compound-wound dynamo, the terminals of the shunt coil are connected with the binding posts of the machine. As the current leaves the armature it has two paths to take : one, the thick series coils, to the external circuit, and the other the finer and longer shunt coils. The resistance of the shunt coils is greater than that of the armature. Current variations in the armature will, therefore, produce no appreciable effect on the magnetizing power of the shunt, which acts as a nearly uniform exciter of the field.

In a shunt-wound dynamo connected to a multiple circuit, the introduction of an additional number of receptive devices into the circuit requires more current, and this would tend to cause a slight drop in the potential. The object of the series coils is to prevent this drop. The series coils, therefore, act as compensators. If the coils are too powerful the compensation will have the effect of increasing the potential.

The combination of a series and separately excited machine is shown in Fig. 351. The field is in series with the armature, but has also an additional and separate excitation.

The combination of a series and shunt machine insures the excitation of the field both by the main and by the shunted current. Such a combination is shown in Fig. 353.

For Constant Current :

The combination of shunt and separately excited machines is shown in Fig. 356. In this machine the field is excited by means of a shunt

to the external circuit, and by a current produced by a separate source.

The combination of a series and magneto machine is shown in Fig. 352. This, also, is designed to give a constant current.

Machine, Dynamo-Electric, Compound-Wound, Long-Shunt — — A compound-wound dynamo-electric machine, in which the shunt-field magnet coils form a shunt to the binding posts of the machine.

In the short-shunt compound-wound dynamo-electric machine, the ends of the shunt coil are connected to the brushes of the machine.

Machine, Dynamo-Electric, Compound-Wound, Short-Shunt — — A compound-wound dynamo-electric machine in which the shunt-field magnet coils form a shunt to the armature only, as distinguished from the armature and series coils combined.

In the short-shunt dynamo-electric machine, the ends of the shunt coil are connected to the brushes of the machine, and not to the binding posts of the machine, or to the external circuit, as in the long-shunt machine.

Machine, Dynamo-Electric, Continuous-Current — — A dynamo-electric machine, the current of which is commuted so as to flow in one and the same direction, as distinguished from an alternating dynamo.

Machine, Dynamo-Electric, Double-Magnet — — A term sometimes applied to a dynamo-electric machine, the field magnets of which have two consequent poles.

Machine, Dynamo-Electric, Economic Co-efficient of — — A name formerly applied to the efficiency of a dynamo-electric machine. (See *Machine, Dynamo-Electric, Efficiency of*.)

Machine, Dynamo-Electric, Efficiency of — — The ratio between the electric energy or the electrical horse-power produced by a dynamo, and the mechanical energy or horse-power expended in driving the dynamo.

The *Efficiency* may be the *Commercial Efficiency*, which is the useful or available energy in the external circuit divided by the total mechanical energy ; or it may be the *Electrical Efficiency*, which is the available electric energy divided by the total electric energy.

The *Efficiency of Conversion* is the total electrical energy developed, divided by the total mechanical energy applied.

If M , equals the mechanical energy,

W , the useful or available electrical energy, and

w , the electrical energy absorbed by the machine, and

m , the *Stray Power*, or the power lost in friction, eddy currents, air friction, etc.

Then, since

$$M = W + w + m,$$

$$\text{Commercial Efficiency} \dots = \frac{W}{M} = \frac{W}{W + w + m}.$$

$$\text{Electrical Efficiency} \dots = \frac{W}{W + w}.$$

$$\text{Efficiency of Conversion} = \frac{W + w}{M} = \frac{W + w}{W + w + m}.$$

Machine, Dynamo-Electric, Flashing of

— —A name given to long flashing sparks at the commutator, due to the short circuiting of the external circuit at the commutator, by arcing over the successive commutator insulating strips.

Machine, Dynamo-Electric, Frame of

— —The bed-piece that supports a dynamo-electric machine.

The frame is sometimes called the dynamo bed-piece.

The word frame is sometimes applied to the field magnet cores and yokes.

Machine, Dynamo-Electric, Local Action of — —(See *Action, Local, of Dynamo-Electric Machine.*)

Machine, Dynamo-Electric, Mouse-Mill,

Sir Wm. Thomson's — —A dynamo-electric machine designed by Sir Wm. Thomson, named from the resemblance of its armature to a mouse mill.

The armature conductor of this dynamo consists of parallel bars of copper, arranged on a hollow cylinder, like the bars on a mouse mill.

Machine, Dynamo-Electric, Multipolar

— —A dynamo-electric machine, the armature of which revolves in a field formed by more than a single pair of poles.

This form is usually adopted for large machines as being more economical.

Fig. 349 shows a multipolar dynamo with four poles.

Machine, Dynamo-Electric, Open-Coil

— —A dynamo-electric machine, the armature coils of which, though connected to

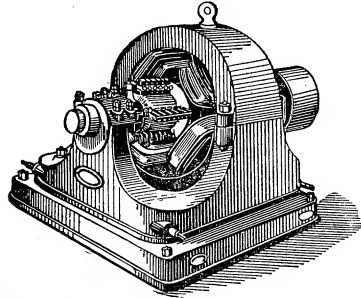

Fig. 349. *Multipolar Dynamo with Four Poles.*

the successive bars of the commutator, are not connected continuously in a closed circuit.

The Brush and the Thomson-Houston arc dynamos are open-coil machines.

Machine, Dynamo-Electric, Open-Coil

Disc — —An open-coil dynamo-electric machine, the armature of which is disc-shaped.

Machine, Dynamo-Electric, Open-Coil

Drum — —An open-coil dynamo-electric machine, the armature core of which is drum-shaped.

Machine, Dynamo-Electric, Open-Coil

Ring — —An open-coil dynamo-electric machine, the armature core of which is ring-shaped.

Machine, Dynamo-Electric, Output of

— —The electric power of the current generated by a dynamo-electric machine expressed in volt-ampères, watts or kilo-watts.

S. P. Thompson suggests that dynamo-electric machines be rated as to their practical safe capacity in *units of output of 1,000 watts*, or one *kilo-watt*. According to this, an 8-unit machine might give, say, 100 ampères at a difference of potential of 80 volts, or 2,000 ampères at a difference of potential of 4 volts. Such a unit would be far more expressive than the usual method of rating a machine as having a capacity of such and such a number of lights.

Machine, Dynamo-Electric, Reaction

Principle of — —The mutual interaction

between the current generated in the armature coils of a dynamo-electric machine and the field of the machine, each strengthening the other until the full working current, which the machine is capable of developing, is produced.

When the armature of a series or shunt dynamo commences to rotate, the differences of potential generated in its coils are very small, since the field of the magnet is weak, being merely the residual magnetism. The current so produced in the armature, circulating through the field magnet coils, increases the intensity of the magnetic field of the machine, and this, reacting on the armature, results in a more powerful current through it. This current again increases the strength of the magnetic field of the machine, which again reacts to increase the current strength in the armature coils, and this continues until the machine is producing its full output.

A dynamo-electric machine very rapidly "builds up," or reaches its maximum current after starting. The reaction principle was discovered by Soren Hjorth, of Copenhagen.

Machine, Dynamo-Electric, Reversibility of — —The ability of a dynamo to act as

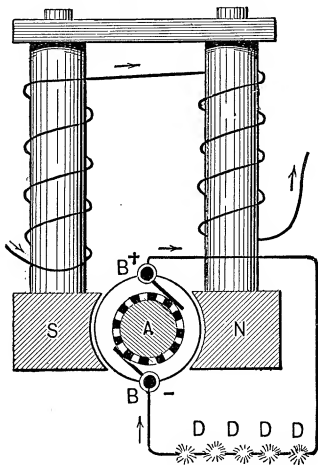

Fig. 350. Separately Excited Dynamo

a motor when traversed by an electric current. (See *Motor, Electric.*)

Machine, Dynamo-Electric, Separate Coil — —A dynamo-electric machine in which the field magnets are excited by means

of coils on the armature, separate and distinct from those which furnish current to the external circuit.

Machine, Dynamo-Electric, Separately Excited — —A dynamo-electric machine in which the field magnet coils have no connection with the armature coils, but receive their current from a separate machine or source.

A separately excited dynamo-electric machine is shown in Fig. 350.

Separate excitation for constant current machines has not come into any extended use in the United States.

Machine, Dynamo-Electric, Series and Magneto — —A compound-wound dynamo-electric machine in which the armature circuit of a magneto-electric machine is connected in series with the armature and field magnet circuits of a series dynamo.

The circuit connections of a series and magneto dynamo are shown in Fig. 351.

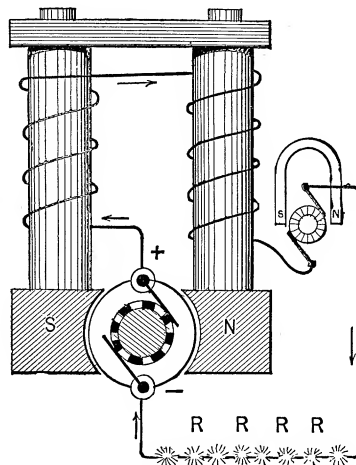

Fig. 351. Series and Magneto Dynamo.

Machine, Dynamo-Electric, Series and Separately Excited — —A compound-wound dynamo-electric machine in which there are two separate circuits on the field magnet cores, one of which is connected in series with the field magnets and the external circuit, and the other with some source by which it is separately excited.

A series and separately excited compound-wound dynamo-electric machine is shown in Fig. 352.

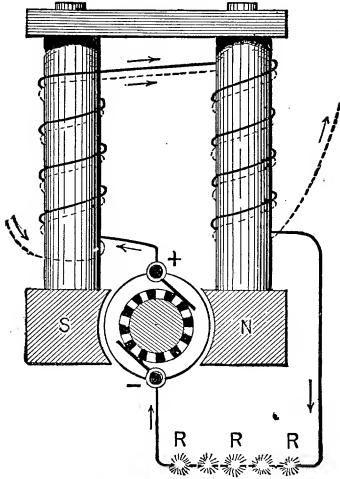

Fig. 352. Series and Separately Excited Dynamo.

This machine is employed for maintaining a constant potential at its terminals.

Machine, Dynamo-Electric, Series and Shunt Wound — — A compound-wound

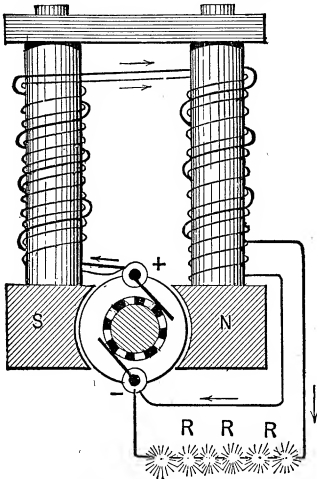

Fig. 353. Series and Shunt-Wound Dynamo.

dynamo-electric machine in which the field magnets are wound with two separate coils, one of which is in series with the armature and the external circuit, and the other in shunt with the armature.

This is usually called a compound-wound machine. (See *Machine, Dynamo-Electric, Compound-Wound.*)

A compound-wound series and shunt dynamo-electric machine is shown in Fig. 353. This machine is designed to maintain constant potential at its terminals.

There are two varieties of series and shunt-wound dynamos, viz.:

- (1.) Long-shunt compound-wound dynamo.
- (2.) Short-shunt compound-wound dynamo.

(See *Machine, Dynamo-Electric, Compound-Wound, Long-Shunt, Machine, Dynamo-Electric, Compound-Wound, Short-Shunt.*)

Machine, Dynamo-Electric, Series-Wound

— — A dynamo-electric machine, in which the field circuit and the external circuit are

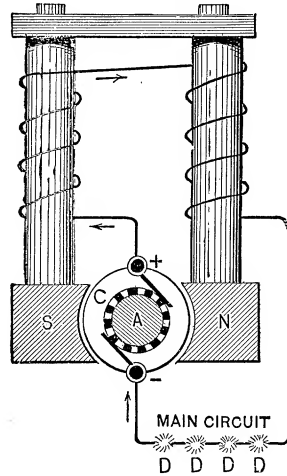

Fig. 354. Series Dynamo.

connected in series with the armature circuit, so that the entire armature current must pass through the field coils.

A series dynamo-electric machine is shown in Fig. 354. Here the armature circuit, the field circuit and the external circuit are all connected in series.

Since in a series-wound dynamo the armature coils, the field and the external series circuit are in series, any increase in the resistance of the external circuit will decrease the electromotive force from the decrease in the magnetizing currents. A decrease in the resistance of the external circuit will, in a like manner, increase the electromotive force from the increase in the magnetizing current.

The use of a regulator avoids these changes in the electromotive force.

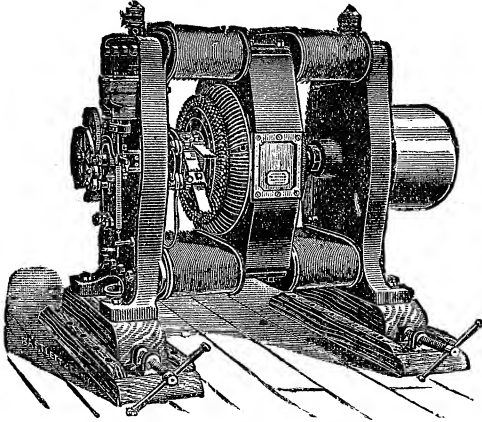

Fig. 355. Series Dynamo.

The dynamo shown in Fig. 355 is series connected. The armature is ring-shaped. The armature core consists of a ring made of soft iron wire. The field is bi-polar, and is obtained by the use of four magnet coils and two consequent poles.

Machine, Dynamo-Electric, Shunt and Separately Excited — A compound-wound dynamo-electric machine, in which

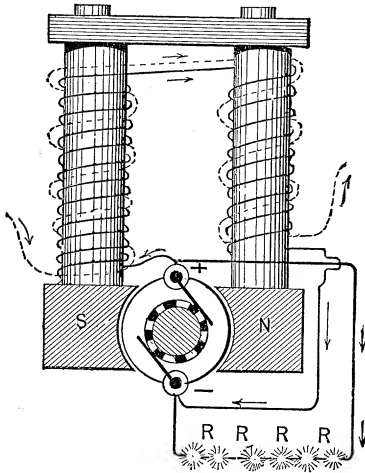

Fig. 356. Shunt and Separately Excited Dynamo.

the field is excited both by means of a shunt to the armature circuit, and by a current produced by a separate source.

A shunt and separately excited compound-

wound dynamo-electric machine is shown in Fig. 356. This machine maintains a constant current in its circuit, notwithstanding changes in its external circuit.

Machine, Dynamo-Electric, Shunt-Wound

— A dynamo-electric machine in which the field magnet coils are placed in a shunt to the armature circuit, so that only a portion of the current generated passes through the field magnet coils, but all the difference of potential of the armature acts at the terminals of the field circuit.

A shunt dynamo-electric machine is shown in Fig. 357.

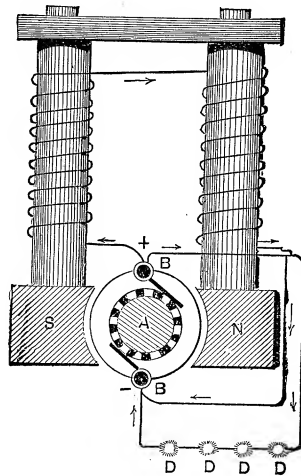

Fig. 357. Shunt Dynamo.

In a shunt dynamo-electric machine, an increase in the resistance of the external circuit increases the electromotive force, and a decrease in the resistance of the external circuit decreases the electromotive force. This is just the reverse of the series-wound dynamo.

In a shunt-wound dynamo a continuous balancing of the current occurs. The current dividing at the brushes between the field and the external circuit in the inverse proportion to the resistance of these circuits, if the resistance of the external circuit becomes greater, a proportionately greater current passes through the field magnets, and so causes the electromotive force to become greater. If, on the contrary, the resistance of the external circuit decreases, less current passes through the field, and the electromotive force is proportionately decreased.

In a shunt-wound dynamo the resistance of the shunt should be at least four hundred times that of the armature. It is sometimes as much as one thousand times as great.—(*Urquhart.*)

To obtain complete regulation of the machine some form of compounding is necessary. (See *Machine, Dynamo-Electric, Compound-Wound.*)

Machine, Dynamo-Electric, Single-Magnet — —A dynamo-electric machine, in which the field magnet poles are obtained by means of a single coil of insulated wire, instead of by more than a single coil.

Machine, Dynamo-Electric, Sparking of — —An irregular and injurious operation of a dynamo-electric machine, attended with sparks at the collecting brushes.

Sparking consists in the formation of small arcs under the collecting brushes. One cause of sparking is to be found in the brushes leaving one commutator strip before making connection with the next strip.

Sparking from this cause may be avoided by so placing the brushes as to cause them to bridge over the space between two consecutive bars, thus permitting them to touch one bar before leaving the other. Two brushes, electrically connected, are sometimes employed for this purpose, or the slots between contiguous bars are slightly inclined to the axis of rotation.

Sparking causes a burning of the commutator strips, and an irregular consumption of the brushes, both of which produce further irregularities by the wear of the brushes against the commutator bars.

At the moment the brush touches two contiguous commutator bars, it short circuits the coil terminating at those bars. On the breaking of this closed circuit, a spark appears under the brushes. This spark is often considerable, since from the comparatively small resistance of the coil, it is apt, when short circuited, to produce a heavy current if not exactly at the neutral point.

Another cause of sparking is to be found in the self-induction of the armature coils. The extra current on breaking forms an injurious spark under the brushes. This spark may be considerable, since the current produced in the coil on momentarily short circuiting it by the brushes simultaneously touching the adjoining commutator segments may be large.

Sparking occurs when the brushes are not set

close to the neutral line. Since the principal cause for the change in the lead of the brushes is the magnetizing effect of the armature coils, it is preferable to make the number of windings of these as few as possible, and to obtain the necessary differences of potential by increasing the speed of rotation and the strength of the magnetic field of the machine. Short armature coils also lessen the sparking due to *self-induction*.

Sparking at the brushes is also caused by the jumping of improperly supported or constructed brushes.

When the brushes are not set close to the neutral point, long *flashing sparks* are apt to occur.

A lack of symmetry of winding of the armature coils will necessarily be attended by injurious flashing, from the impossibility of properly adjusting the brushes.

Machine, Dynamo-Electric, Synchronizing — —Adjusting the phases of two alternating current dynamos so as to permit their being coupled or joined in parallel.

Machine, Dynamo-Electric, to Short Circuit a — —To put a dynamo-electric machine on a circuit of comparatively small electric resistance.

Machine, Dynamo-Electric, Unit of Output of — —A unit for the electric power furnished by the current of a dynamo-electric machine.

A unit of output equal to 1,000 watts or 1 kilowatt.

A machine furnishing a current of 100 ampères at a difference of potential of 80 volts, would have an output of 8,000 watts, and would, therefore, be rated as an 8-unit machine.

Machine, Electric, Rubber of — —A cushion of leather covered with an electric amalgam, and employed to produce electricity by its friction against the plate or cylinder of a frictional electric machine. (See *Machine, Frictional Electric.*)

Machine, Electrostatic Induction — — A machine in which a small initial charge produces a greatly increased charge by its inductive action on a rapidly rotated disc of glass or other dielectric.

An excellent type and example of such a machine is found in the Holtz machine, which con-

sists of the following parts, as shown in Fig. 358, viz.:

- (1.) A stationary glass plate A, fixed at its edges to insulated supports.
- (2.) A movable plate B, capable of rapid rotation on a horizontal axis, by a driving pulley.

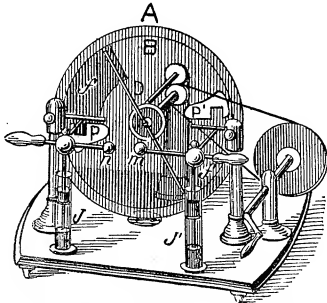

Fig. 358. Holtz Electric Machine.

(3.) Armatures of varnished paper f, f' , placed on opposite sides of the fixed plate at holes or windows P, P' , cut in the plate. The armatures are placed on the side of the fixed plate away from the moving plate, or on the back of the plate, so that the plate, on its rotation, moves *towards* tongues of paper attached to the middle of the armature.

(4.) Metal combs placed in front of the movable disc opposite the armatures, and connected with the brass balls m, n , one of which is movable towards and from the other by means of a suitably supported insulating handle connected with it.

A small initial charge is given to one of the armatures by holding a plate of electrified vulcanite against it, and rotating the machine *while* the balls m, n , are in contact. As soon as the machine is charged the balls are *gradually separated*, when a torrent of sparks will pass between them so long as the plate is rotated.

When the balls are separated too far the sparks cease to pass. The balls must then be again brought into contact and gradually separated as before.

The Holtz machine can be regarded as a revolving *electrophorus* provided with means for constantly discharging and recharging the upper metallic plate. (See *Electrophorus*.)

The action of the machine is well described by S. P. Thompson in his "Elementary Lessons on Electricity and Magnetism," as follows:

"Suppose a small $+$ charge to be imparted at the outset to the right armature f' ; this charge acts

inductively across the discs upon the metallic comb, repels electricity through it, and leaves the points negatively electrified. They discharge negatively electrified air upon the front surface of the movable disc; the repelled charge passes through the brass rods and balls, and is discharged through the left comb upon the front side of the movable disc. Here it acts inductively upon the paper armature, causing that part of it which is opposite itself to be negatively charged and repelling a $+$ charge into its farthest part, viz., into the tongue, which being bluntly pointed, slowly discharges a $+$ charge upon the *back* of the movable disc. If now the disc be turned round, this $+$ charge on the back comes over from the left to the right side, in the direction indicated by the arrow, and, when it gets opposite the comb, increases the inductive effect of the already existing $+$ charge on the armature, and therefore repels more electricity through the brass rods and knob into the left comb. Meantime the $-$ charge, which we saw had been induced in the left armature, has in turn acted on the left comb, causing a $+$ charge to be discharged by the points upon the front of the disc; and drawing electricity through the brass rods and knobs, has made the right comb still more highly $-$, increasing the discharge of $-$ ly electrified air upon the front of the disc, neutralizing the $+$ charge which is being conveyed over from the left. These actions result in causing the top half of the moving disc to be $-$ ly electrified. The charges on the front serve, as they are carried round, to neutralize the electricities let off by the points of the combs, while the charges on the back, induced respectively in the neighborhood of each of the armatures, serve, when the rotation of the disc conveys them round, to increase the inductive influence of the charge on the other armature."

The student will be aided in following Prof. Thompson's explanation by the diagrammatic sketch, shown in Fig. 359. Here the rotating plate is shown for convenience in the form of a cylinder. The armatures are shown on the back of the plate at f' and f , opposite the brass collecting combs P' and P , with their discharging rods and balls a, a .

The effect of the positive charge given to the right hand armature f' , directly through the comb P' , rods a, a , comb P , to left hand armature f , is readily seen. The rotation of the plate being in the direction of the curved arrows, the charging of the front of the plate by convection streams from the combs, and the back of the plate

from the points of the paper armatures, as well as the character of the charge, will be understood. There thus results, as is shown, a positive charge on both the front and back of the upper half of

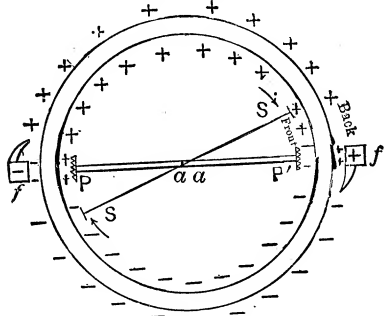

Fig. 359. Plate of Holtz Machine.

the rotating plate, and a negative charge on both sides of its lower half. A reversal of polarity of the plate occurs at the line P a P'. Sometimes the reversal does not occur, and the machine either loses its charge entirely, or in part. A conductor S S, furnished with points, is sometimes provided to lessen the chances of lack of reversal.

Machine, Faradic — — A machine for producing faradic currents.

There are two varieties of faradic machines, viz.: magneto-faradic apparatus and simple induction apparatus.

Machine, Frictional Electric — — A machine for the development of electricity by friction.

A frictional electric machine consists of a plate or cylinder of glass A, Fig. 360, capable of rotation on a horizontal axis.

A rubber formed of a chamois skin, covered with an amalgam of tin and mercury, is placed at B. By the rotation of the plate the

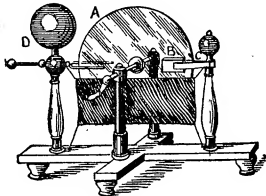

Fig. 360. Frictional Electric Machine.

rubber becomes negatively and the glass positively excited. An insulated conductor D, called the *prime* or *positive conductor*, provided with a

comb of points, becomes positively charged by induction. The machine will develop electricity best if a conductor attached to the rubber is connected with the ground, as by a chain.

Machine, Holtz — — A particular form of electrostatic induction machine. (See *Machine, Electrostatic Induction*.)

Machine, Influence — — An electrical machine depending for its action on electrostatic induction.

The Wimshurst and Holtz machines are influence machines. (See *Machine, Electrostatic Induction. Machine, Wimshurst Electrical. Machine, Holtz*.)

Machine, Influence, Wimshurst's Alternating — — An electrostatic induction machine by means of which a series of rapidly alternating charges are produced.

Although such a machine furnishes a torrent of sparks between its terminals, yet it is unable to furnish a permanent charge to a Leyden jar or condenser, since its oscillatory discharges, continually undo at any small interval of time, what was done at the preceding interval, and thus leave the jar uncharged.

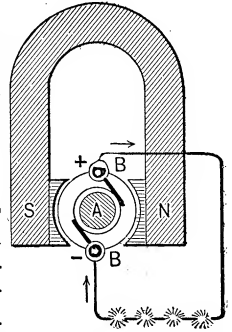

Fig. 361. Magneto-Electric Machine.

Machine, Magneto Blasting — — A magneto-electric machine employed for generating the current used in electric blasting.

Machine, Magneto-Electric — — A machine in which there are no field magnet coils, the magnetic field of the machine being due to the action of permanent steel magnets.

A dynamo in which currents are produced by the motion of armature coils past permanent magnets. (See *Machine, Dynamo-Electric*.)

A magneto-electric machine is shown in Fig. 361.

Another form of magneto-electric machine is shown in Fig. 362.

This latter form of machine is known as a hand generator, in contradistinction to one driven by power and called a power generator.

The field is obtained by means of a number of separate permanent magnets so combined as to

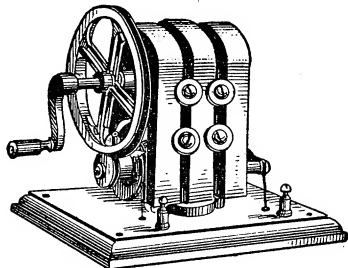

Fig. 362. Magneto-Electric Machine.

act as a single magnet. The armature is rotated by hand.

Machine, Mouse-Mill — — A form of convection induction machine, invented by Sir William Thomson to act as the replenisher of his electrometer. (See *Machine, Electrostatic Induction.*)

Machine, Rheostatic — — A machine devised by Planté in which continuous static effects of considerable intensity are obtained by charging a number of condensers in multiple-arc and discharging them in series.

The condensers are charged by connecting them with a number of secondary or storage batteries.

Machine Telegraphy.—(See *Telegraphy, Machine.*)

Machine, Töppler-Holtz — — A modified form of Holtz machine in which the initial charge of the armatures is obtained by the friction of metallic brushes against the armatures.

Machine, Wimshurst Electrical — — A form of convection electric machine invented by Wimshurst.

Like the Holtz machine, the Wimshurst machine is a convection induction machine. It is, however, more efficient in action, and will probably soon supersede the former machine. The Wimshurst machine consists of two shellac-varnished glass plates that are rapidly rotated in opposite directions. Thin metallic strips are placed on the outside of each of the plates, in the radial positions shown in Fig. 363. These strips act

both as *inductors* and *carriers*; the carriers of one plate acting as inductors to the other plate.

Two curved brass rods, terminating in fine wire brushes that touch the plates, are placed as shown, one at the front of the plate, and one at the back, at right angles to each other. Pairs of conduct-

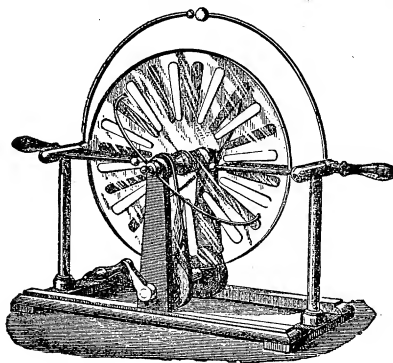

Fig. 363. The Wimshurst Electrical Machine.

ors, connected together, provided with collecting points, are placed diametrically opposite each other, as shown. Sliding conductors, terminated with metallic balls, are provided for discharging the conductors. Leyden jars, the inner coatings of which are connected with two discharging rods, and the outer coatings together, may be employed in this as in the Holtz machine.

The exact action of this machine is not thoroughly understood.

Machines, Dynamo-Electric, Varieties of — — Dynamo-electric machines may be divided into classes according to—

- (1.) The manner in which the magnetism of the field magnets is obtained.
- (2.) The character of their armatures.
- (3.) The nature of the current obtained, whether continuous or alternating.
- (4.) The form of their field magnets.
- (5.) The nature of their magnetic fields.
- (6.) The manner in which the current of the field magnets, the armature and the external circuits are connected.

Mack — — A term proposed by Mr. Oliver Heaviside for a unit of self-induction.

The term Mack is derived from Maxwell. The unit of self-induction has also been a secohm and a quadrant.

The term Max would seem to be indicated. In the United States the unit of self-induction is called a Henry, after Prof. Joseph Henry. (See *Henry, A.*)

Made Circuit.—(See *Circuit, Made.*)

Magazine Fuse.—(See *Fuse, Magazine.*)

Magne-Crystalline Action.—(See *Action, Magne-Crystalline.*)

Magnet.—A body possessing the power of attracting the unlike pole of another magnet or of repelling the like pole; or of attracting readily magnetizable bodies like iron filings to either pole.

A body possessing a magnetic field. (See *Field, Magnetic.*)

The lines of force are assumed in passing through the magnetic field to come out at the north pole of the magnet and to go in at the south pole. All lines of force form closed magnetic circuits. If a magnetizable body is brought into a magnetic field, the lines of magnetic force are concentrated on it and pass through it. The body therefore becomes magnetic. The intensity of the resulting magnetism depends on the number of lines of force that pass through the body, and the polarity on the direction in which they pass through it.

A magnetized bar cannot be regarded as a source of energy in itself. Energy must be expended to magnetize the iron, and must also be expended to demagnetize it.

Magnet, Anomalous — —A magnet possessing more than two free poles.

There is no such thing as a unipolar magnet.

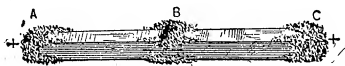

Fig. 364. Anomalous Magnet.

All magnets have two poles. Sometimes, however, several magnets are so grouped that there appear to be more than two poles in the same magnet.

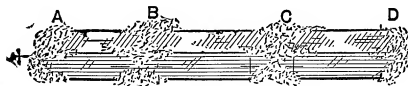

Fig. 365. Anomalous Magnet.

Thus, in Fig. 364, the magnet A B C, appears to possess three poles, two positive poles at A and C, and a central negative pole at B.

It is clear, however, that the central pole is in reality formed of two juxtaposed negative poles, and that A B C, actually consists of two magnets with two poles to each.

The magnet A B C D, Fig. 365, which in like manner appears to possess four separate poles, in reality is formed of three magnets with two poles to each.

Since unlike magnetic poles neutralize each other, it is clear that only similar poles can thus be placed together in order to produce additional magnet poles.

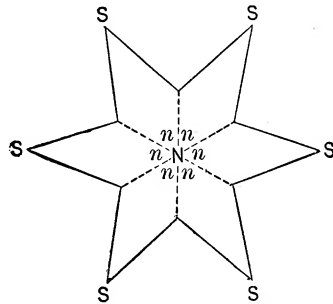

Fig. 366. Anomalous Magnet.

The six-pointed star shown in Fig. 366, is an anomalous magnet with apparently seven poles. The formation of the central N-pole, as is evident from an inspection of the drawing, is due to the six separate north poles, n, n, n, n, n, n, of the six separate magnets Sn, Sn, etc. Such a magnet would be formed by touching the star at the point N, with the S-pole of a sufficiently powerful magnet.

The extra poles are sometimes called *consequent poles*. Their presence may be shown by means of a compass needle, or by rolling the magnet in iron filings, which collect on the poles.

Magnet, Artificial — —A magnet produced by induction from another magnet, or from an electric current.

Any magnet not found in nature is called an artificial magnet.

Magnet, Axial — —A name sometimes given to a solenoid with an axial or straight core.

Magnet, Bell-Shaped — —A modification of a horseshoe magnet in which the approached poles are semi-annular in shape, and form a split tube.

Bell-shaped magnets are used in many galva-

nometers, because they can be readily dampened by surrounding them by a mass of copper. The needle in its motion produces currents that tend to oppose, and, therefore, to stop its motion. (See *Laws, Lenz's.*)

Magnet, Club-Footed — —An electro-magnet whose core is in the form of a horse-shoe and is provided with a magnetizing coil on one pole only.

Magnet Coil.—(See *Coil, Magnet.*)

Magnet, Compensating — —A magnet placed over a magnetic needle, generally over the magnetic needle of a galvanometer, for the purpose of varying the direction and intensity of the magnetic force of the earth on such needle. (See *Galvanometer, Reflecting.*)

A magnet, called a *compensating magnet*, is sometimes placed on a ship, near the compass needle, for the purpose of neutralizing the local variations produced on the compass needle by the magnetism of the ship.

Magnet, Compound — —A number of single magnets, placed parallel and with their similar poles facing one another, as shown in Fig. 367.

Compound magnets are stronger in proportion to their weight than single magnets.

Magnet, Compound Horseshoe — —A horse-shoe magnet composed of several separate horseshoe magnets placed with their similar poles together.

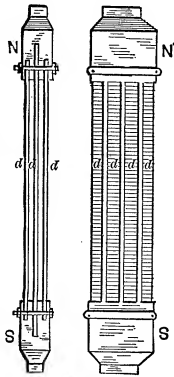

Fig. 367. Compound Magnet.

A compound horseshoe magnet is shown in Fig. 368.

A horseshoe magnet possesses greater portative power than a straight bar magnet of the same weight. (See *Power, Portative.*)

(1.) Because its opposite poles are nearer together; and

(2.) Because the magnetic resistance of its circuit is less, the lines of magnetic force closing through the armature, and thus concentrating the magnetic attraction on the armature.

Electro-magnets are generally made of the horseshoe shape.

Magnet, Controlling — —A name

sometimes applied to the controller in the Thomson-Houston automatic system of current regulation. (See *Controller.*)

Generally any magnet which controls some particular action.

Magnet, Cylindrical — —A magnet in the shape of a cylinder.

A helix or solenoid through which a current of electricity is passing is, so far as external space is concerned, the exact magnetic equivalent of a cylindrical magnet.

Magnet, Damping — —Any magnet

employed for the purpose of checking the velocity of motion of a moving body or magnet.

Damping magnets generally act by the resistance which they offer to the passage of a metallic disc, so moved as to cut the lines of force of their field.

Magnet, Electro — —A magnet produced by the passage of an electric current through a coil of insulated wire surrounding a core of magnetizable material.

The magnetizing coil is called a helix or solenoid. (See *Magnetism, Ampère's Theory of.*)

Strictly speaking, the term electro-magnet is limited to the case of a magnet provided with a soft iron core, which enables it to rapidly acquire its magnetism on the passage of the magnetizing current, and as rapidly to lose its magnetism on the cessation of such current.

An electric current passed around a bar of magnetizable material, in the manner and direction shown in Fig. 369, will produce the polarity N and S, at its ends or extremities as marked.

The directions of the currents required to produce N and S, poles respectively are shown in Fig. 370.

The cause of this difference of polarity will be readily understood from a study of the direction

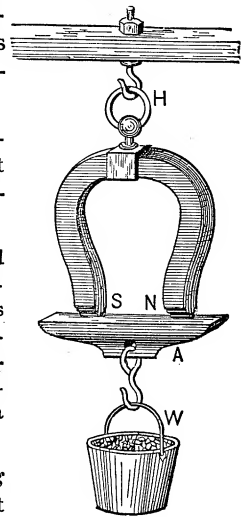

Fig. 368. Compound Horseshoe Magnet.

of lines of magnetic force in the field produced by an electric current.

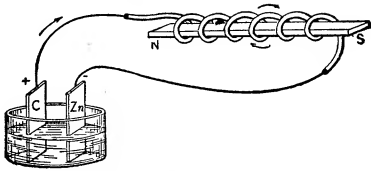

Fig. 369. Polarity of Current.

The direction of this polarity may be predicted by the following modification of a rule by Ampère:

Imagine yourself swimming in the wire in the direction of the current; if, then, your face is

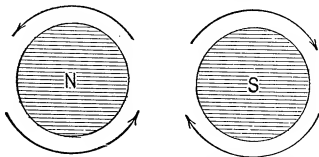

Fig. 370. North and South Magnet Poles.

turned toward the bar that is being magnetized, its North seeking pole will be on your left.

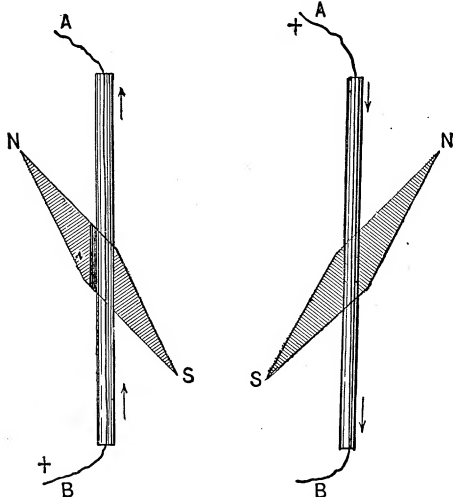

Fig. 371. Deflection of Magnetic Needle.

Fig. 372. Deflection of Magnetic Needle.

If, for example, the conductor A B, be traversed by a current in the direction from B, to A, as shown in Fig. 371, the north pole N, of the needle N S, placed under the conductor, is deflected, as shown, to the left of the observer, who is supposed to be swimming in the current, facing the needle. If the current flow in the opposite

direction, as from A, to B, as shown in Fig. 372, the N, pole of the needle is deflected as shown, but still to the left of the observer supposed to be swimming as before.

In any electric circuit, the lines of magnetic force, produced by the passage of the current, form circles around the circuit in planes at right angles to the direction of the current, as shown in Fig. 373. The direction of these lines of force is the same as that of the hands of a watch, if the current be supposed to flow away from the observer. (See *Field, Magnetic, of an Electric Current.*)

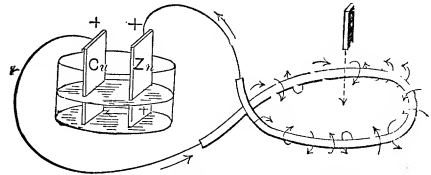

Fig. 373. Direction of Lines of Force.

Remembering now that the lines of force are supposed to come out at the north pole of a magnet, and to pass in at the south pole, it is evident that if the current flows in the direction shown in Fig.

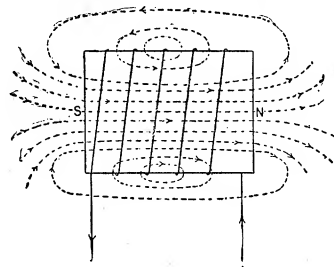

Fig. 374. Direction of Lines of Force.

374, the lines of force will come out at the north pole and pass in at the south pole.

Since in a right-handed helix the wire passes around the axis in the opposite direction to that in which it passes in a left-handed helix, it is evident that the helices shown in Fig. 375 at 1, and 2, will produce opposite polarities at the points of entrance and exit by a current flowing in the direction of the arrows.

If the current be sent through the right-handed helix, shown at 1, from b, to a, that is, from the left to the right in the figure, a south pole will be produced at b, and a north pole at a. If, however, it be sent from a, to b, the polarity will be reversed.

If the current be sent through the left-handed

helix, shown at 2, from a, to b, that is, from the left to the right in the figure, a north pole will be produced at a, and a south pole at b. If, however, it be sent in the opposite direction, the polarity will be reversed.

Therefore, in an electro-magnet, on the core of which several layers or thicknesses of wire are wound, in which the current flows through one layer, in, say a direction from right to left, the current must return through the next layer in the opposite direction, or from left to right. The polarities of the same extremities of the helices are, however, the same in all cases, *since the layers are successively right and left handed* to the current. The winding shown at 3, produces consequent poles.

The following laws express the more important principles concerning electro-magnets:

(1.) The magnetic intensity (strength) of an electro-magnet is nearly proportional to the strength of the magnetizing current, provided the core is not saturated.

(2.) The magnetic strength is proportional to the number of turns of wire in the magnetizing coil; that is, to the number of ampère turns. (See *Turns, Ampère.*)

(3.) The magnetic strength is independent of the thickness or material of the conducting wires.

These laws may be embraced in the more general statement that the strength of an electro-

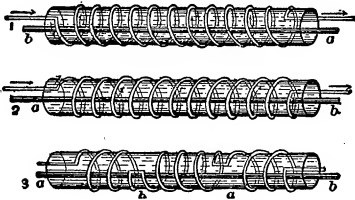

Fig. 375. Right-Handed, Left-Handed and Anomalous Helices.

magnet, the size of the magnet being the same, is proportional to the number of its ampère turns. (See *Turns, Ampère.*)

A short interval of time is required for a current to thoroughly magnetize a powerful electro-magnet.

A few moments are also required for a powerful magnet to thoroughly lose its magnetism. At the same time electro magnets are capable of acquiring or losing their magnetism with very great rapidity. It is, in fact, on this ability possessed to so remarkable a degree by soft iron, that

the value of an electro-magnet for many purposes depends. (See *Lag, Magnetic.*)

A difference exists between the action of a magnetized disc and a hollow coil of wire through which a current of electricity is passing. So far as the space outside either is concerned, the action is the same, but the coil is penetrable on the inside and the disc is not, and for the inside of the space, therefore, there is a difference in the action.

Magnet, Electro, Bar — — An electro-magnet, the core of which is in the form of a straight bar or rod.

Magnet, Electro, Cylindrical — — An electro-magnet, the core of which consists of a hollow cylinder provided with a slot extending parallel to its axis.

The gap in the cylinder suffices for the placing of the magnetizing coils, and forms the poles. This form of electro-magnet was devised by Joule. Its construction will be understood from an inspection of Fig. 376.

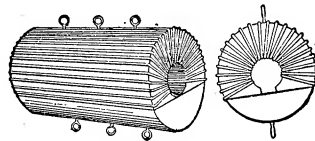

Fig. 376. Cylindrical Electro-Magnet.

Magnet, Electro, Horseshoe — — An electro-magnet, the core of which is in the shape of a horseshoe or U.

Magnet, Electro, Hughes' — — An electro-magnet in which a U-shaped permanent magnet is provided with pole pieces of soft iron, on which only are placed the magnetizing coils.

A quick acting electro-magnet, in which the magnetizing coils are placed on soft iron pole pieces that are connected with and form the prolongations of the poles of a permanent horseshoe magnet.

Hughes devised this form of electro-magnet in order to obtain the best effects from currents of but short duration.

He thus obtained a quick acting magnet, necessary to insure the success of his system of printing telegraph, where the magnetizing currents at times have a duration of but the .20 of a second.

Magnet, Electro, Joule's Cylindrical — —An electro-magnet provided with a hollow cylindrical core. (See *Magnet, Electro, Cylindrical*.)

Magnet, Electro, Iron-Clad — —An electro-magnet whose magnetizing coil is almost entirely surrounded by iron.

The effect of the iron casing is to greatly reduce the magnetic resistance of the circuit. A form of iron-clad electro-magnet is shown in Fig. 377. Here one of the poles is connected with a casing of iron, external to the coils, and is thus brought nearer to the other pole.

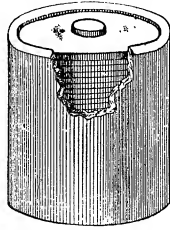

Fig. 377. Iron-Clad Electro-Magnet.

Magnet, Electro, Long-Core — —An electro-magnet with a long core of iron.

A long-core electro-magnet magnetizes and demagnetizes much more slowly than a short-core electro-magnet.

Magnet, Electro, Short-Core — —An electro-magnet with a short core of iron.

A short-core electro-magnet possesses the power of being magnetized and demagnetized much more rapidly than a long-core magnet.

Magnet, Electro, Yoked-Horseshoe — —A horseshoe electro-magnet, in which the two straight limbs are formed of two straight rods or bars, yoked together at one pair of ends by a yoke or bar of iron.

In some cases the magnetizing coils are placed on each of the limbs. Sometimes, however, a single coil is placed at the middle of the yoke and the limbs are left bare.

Even with the closest possible fitting the resistance of the magnetic circuit is much greater in this form of electro-magnet, owing to the smaller permeability of the air gap at the joints, than it would be if the entire core were made of a single piece of iron. A yoked electro-magnet is, however, more convenient to make and use.

Magnet, Electro, Zigzag — —A multipolar electro-magnet, the magnetizing coils of which are separately wound in grooves cut in the face of straight or curved bars.

A form of zigzag electro-magnet devised by Joule is shown in Fig. 378. The spiral character of the winding produces the alternate North and South polarities shown in the figure.



Fig. 378. Zigzag Electro-Magnet.

Magnet, Equator of — —A point approximately midway between the poles of a straight bar magnet, or nearly midway from the poles of a horseshoe magnet if measured along the bar from each pole.

This term was proposed by Dr. Gilbert. It is now almost entirely displaced by the term *neutral point*.

Magnet, High-Resistance — —A term sometimes used in place of long-coil magnet whose coils have a high electric resistance. (See *Magnet, Long-Coil*.)

The term long-coil magnet is, perhaps, the preferable one, because the resistance of a coil, *per se*, has nothing to do with its magnetizing power, which is determined by its ampère turns. (See *Turns, Ampère. Magnet, Long Coil*.)

Magnet, Horseshoe — —A magnetized bar of steel or iron bent in the form of a horseshoe or letter U.

Magnet, Iron-Clad — —A magnet whose magnetic resistance is lowered by a casing of iron connected with the core and provided for the passage of the lines of magnetic force. (See *Magnet, Tubular*.)

Magnet, Jacketed — —A term sometimes applied to a form of iron-clad magnet. (See *Magnet, Iron-Clad*.)

Magnet, Keeper of — —A mass of soft iron applied to the poles of a magnet through which its lines of magnetic force pass. (See *Field, Magnetic*.)

The keeper of a magnet differs from its *armature* in that the keeper while acting as such is always kept on the poles to prevent loss of magnetization, while the armature, besides acting as a keeper, may be attracted towards, or, if an electro-magnet, be repelled from the magnet poles. While performing its functions the keeper is always fixed, the armature generally, though

not always, is in motion. A keeper is, of course, only used with permanent magnets.

Opinion is divided as to the efficacy of the keeper in preventing loss of magnetization in certain cases.

Magnet, Long-Coil — —An electro-magnet whose magnetizing coil consists of many turns of thin wire.

Magnet, Low-Resistance — —A term sometimes used in place of short-coil magnet. (See *Magnet, Short-Coil*.)

This term, *short-coil magnet*, is the preferable one.

Magnet, Marked Pole of — —A name formerly applied to that pole of a magnet which points approximately to the geographical north.

If the pole of the magnet that points to the geographical north be in reality the north pole of the magnet, then the earth's magnetic pole in the Northern Hemisphere is of south magnetic polarity. In the United States, and Europe generally, this is regarded as the fact.

The French, however, formerly called the pole of the needle that points to the earth's geographical north the *south* or *austral* pole. In America and England it is called the *north pole*, the *marked pole*, or the *north-seeking pole*, and the Northern Hemisphere is assumed to possess south magnetic polarity. (See *Pole, Magnetic, Austral. Pole, Magnetic, Boreal*.)

Magnet, Moment of — —The effective force of a magnetic couple as obtained by multiplying one of the forces of the couple by the perpendicular distance between the directions of the forces.

The moment of a magnet is equal to the product of the volume of the magnet and the intensity of magnetization, or simply its magnetization.

Magnet, Natural — —A name sometimes given to a lodestone. (See *Lodestone*.)

Magnet, Neutral Line of — —(See *Line, Neutral, of a Magnet*.)

Magnet, Permanent — —A magnet of hardened steel or other paramagnetic substance which retains its magnetism for a long time after being magnetized.

A permanent magnet is distinguished, in this respect, from a temporary magnet of soft iron, which loses its magnetization very shortly after being taken from the magnetizing field.

Magnet, Portative Power of — —The lifting power of a magnet.

The *portative* or *lifting power* of a magnet, depends on the form of the magnet, as well as on its strength. A horseshoe magnet, for example, will lift a much greater weight than the same magnet if in the form of a straight bar.

This is due not only to the mutual action of the approached poles, but also to the decreased resistance of the magnetic circuit, and to the greater number of lines of magnetic force that pass through the armature. The portative power is proportional to the area of contact and the square of the magnetic intensity, the formula being

$$P = \frac{A \times B^2}{8 \pi \times 981},$$

in which P, is the lifting power in grammes, A, the area of contact in square centimetres, and B, is the number of lines of force per square centimetre.

Magnet Operation. — (See *Operation, Magnet*.)

Magnet, Receiving — —A name sometimes given to the relay of a telegraphic system. (See *Relay*.)

In general, any magnet, used directly in the receiving apparatus, at the receiving end of a line connecting a system of electric communication between transmitting and receiving instruments.

Magnet, Regulator — —A magnet, the operation of which is to automatically effect any desired regulation.

The magnet in the Thomson-Houston system of automatic regulation, by means of which the commutator collecting brushes are automatically shifted to such positions on the commutator as will maintain the current practically constant, despite the changes in the resistance of the circuit external to the machine. (See *Regulation, Automatic*.)

Magnet, Relay — —An electro-magnet, whose coils are connected to the main line of a telegraphic circuit, and the movements of

whose armature is employed to bring a local battery into action at the receiving station, the current of which operates the register or sounder.

Magnet, Short-Coil — —An electro-magnet whose magnetizing coil consists of a few turns of short, thick wire.

Magnet, Simple — —A simple magnetized bar.

The term simple magnet is used in contradistinction to compound magnet. (See *Magnet, Compound*.)

Magnet, Sluggish — —A magnet that magnetizes or demagnetizes sluggishly.

An electro-magnet becomes sluggish when surrounded by a sheathing of copper, on account of the currents induced in the sheathing in a direction opposite to those passing through the magnetizing coil.

Magnet, Solenoidal — —A thin, uniformly magnetized straight bar of steel, of such a length that its poles, situated at extremities or ends of its longer axis, act on external objects as if equal and opposite quantities of magnetism were concentrated at such extremities.

It derives its name solenoidal from the similarity between its action and that of a solenoid. Unless very carefully magnetized, a magnet will not act as a solenoidal magnet. (See *Magnet, Electro. Magnetism, Solenoidal Distribution of*.)

Magnet, Tubular — —A form of horseshoe magnet, in which one pole is brought near the opposite pole by a hollow cylinder or tube of iron, which is placed in contact with one of the magnetic poles, so as to completely surround the other, except in the plane of cross-section of that pole.

A form of iron-clad magnet. (See *Magnet, Iron-Clad*.)

There is thus obtained a magnet, with two concentric poles, one solid and the other annular, the portative power of which is much greater than that of a horseshoe magnet of equal dimensions.

Magnet, Field, of Dynamo-Electric Machine — —One of the electro-magnets employed to produce the magnetic field of a dynamo-electric machine.

The field magnets consist of a suitable *frame*, or *core*, on which the *field magnet coils* are wound.

The *field magnet cores* are made of thick and solid iron, as soft as possible. They should contain plenty of iron in order to avoid too ready *magnetic saturation*.

All edges and corners are to be avoided, since they tend to cause an irregular distribution of the field.

The field magnets should in general have sufficient magnetic strength to prevent the magnetizing effect of the armature from unduly influencing the field, and thus, by causing too great a *lead*, produce injurious *sparking*.

Magnetic or Magnetical.—Pertaining to magnetism.

Magnetic Adherence.—(See *Adherence, Magnetic*.)

Magnetic Air Circuit.—(See *Circuit, Air, Magnetic*.)

Magnetic Air Gap.—(See *Gap, Air, Magnetic*.)

Magnetic Attraction.—(See *Attraction, Magnetic*.)

Magnetic Axis.—(See *Axis, Magnetic*.)

Magnetic Axis of a Straight Needle.—(See *Axis, Magnetic, of a Straight Needle*.)

Magnetic Azimuth.—(See *Azimuth, Magnetic*.)

Magnetic Battery.—(See *Battery, Magnetic*.)

Magnetic Bridge.—(See *Bridge, Magnetic*.)

Magnetic Circuit.—(See *Circuit, Magnetic*.)

Magnetic Closed-Circuit.—(See *Circuit, Closed Magnetic*.)

Magnetic Conductance.—(See *Conductance, Magnetic*.)

Magnetic Core, Closed — —(See *Core, Closed-Magnetic*.)

Magnetic Core, Open — —(See *Core, Open-Magnetic*.)

Magnetic Couple.—(See *Couple, Magnetic*.)

Magnetic Curves.—(See *Curves, Magnetic.*)

Magnetic Day of Disturbance.—(See *Day of Disturbance, Magnetic.*)

Magnetic Declination.—(See *Declination.*)

Magnetic Density.—(See *Density, Magnetic.*)

Magnetic Dip.—(See *Dip, Magnetic.*)

Magnetic Elements of a Place.—(See *Elements, Magnetic, of a Place.*)

Magnetic Equalizer.—(See *Equalizer, Magnetic.*)

Magnetic Explorer.—(See *Explorer, Magnetic.*)

Magnetic, Ferro — —Magnetic after the manner of iron or other paramagnetic body. (See *Paramagnetic.*)

Magnetic Field.—(See *Field, Magnetic.*)

Magnetic Field, Reversing — —(See *Field, Magnetic, Reversing.*)

Magnetic Field, Shifting — —(See *Field, Magnetic, Shifting.*)

Magnetic Figures.—(See *Figures, Magnetic. Field. Magnetic.*)

Magnetic Filament. — (See *Filament, Magnetic.*)

Magnetic Flow.—(See *Flow, Magnetic.*)

Magnetic Flux.—(See *Flux, Magnetic.*)

Magnetic Force.—(See *Force, Magnetic.*)

Magnetic Inclination.—(See *Inclination, Magnetic.*)

Magnetic Induction.—(See *Induction, Magnetic.*)

Magnetic Induction, Dynamic — — (See *Induction, Magnetic, Dynamic.*)

Magnetic Induction, Static — — (See *Induction, Magnetic, Static.*)

Magnetic Inertia.—(See *Inertia, Magnetic.*)

Magnetic Intensity. — (See *Intensity, Magnetic.*)

Magnetic Joint.—(See *Joint, Magnetic.*)

Magnetic Lag.—(See *Lag, Magnetic.*)

Magnetic Latitude.—(See *Latitude, Magnetic.*)

Magnetic Leakage.—(See *Leakage, Magnetic.*)

Magnetic Lines of Force.—(See *Force, Magnetic, Lines of.*)

Magnetic Mass.—(See *Mass, Magnetic.*)

Magnetic Memory.—(See *Memory, Magnetic.*)

Magnetic Meridian.—(See *Meridian, Magnetic.*)

Magnetic Moment.—(See *Moment, Magnetic.*)

Magnetic Normal Day.—(See *Day, Normal, Magnetic.*)

Magnetic Observatory.—(See *Observatory, Magnetic.*)

Magnetic Output.—(See *Output, Magnetic.*)

Magnetic Parallel.—(See *Parallels, Magnetic.*)

Magnetic Permeability.—(See *Permeability, Magnetic.*)

Magnetic Permeance.—(See *Permeance, Magnetic.*)

Magnetic Permeation.—(See *Permeation, Magnetic.*)

Magnetic Poles.—(See *Poles, Magnetic.*)

Magnetic Poles, False — — (See *Pole, Magnetic, False.*)

Magnetic Proof Piece.—(See *Piece, Magnetic Proof.*)

Magnetic Proof Plane.—(See *Plane, Proof, Magnetic.*)

Magnetic Reluctance.—(See *Reluctance, Magnetic.*)

Magnetic Repulsion.—(See *Repulsion, Magnetic.*)

Magnetic Resistance.—(See *Resistance, Magnetic.*)

Magnetic Retardation.—(See *Retardation, Magnetic.*)

Magnetic Retentivity.—(See *Retentivity, Magnetic.*)

Magnetic Saturation.—(See *Saturation, Magnetic.*)

Magnetic Screen or Shield.—(See *Screen or Shield, Magnetic.*)

Magnetic Screening.—(See *Screening, Magnetic.*)

Magnetic Self-Induction.—(See *Induction, Self, Magnetic.*)

Magnetic Shells.—(See *Shells, Magnetic.*)

Magnetic Shunt.—(See *Shunt, Magnetic.*)

Magnetic, Sidero — — A term proposed by S. P. Thompson to replace the term ferromagnetic. (See *Magnetic, Ferro.*)

Magnetic Solenoid.—(See *Solenoid, Magnetic.*)

Magnetic Sounds.—(See *Sounds, Magnetic.*)

Magnetic Spin.—(See *Spin, Magnetic.*)

Magnetic Storm.—(See *Storm, Magnetic.*)

Magnetic Strain.—(See *Strain, Magnetic.*)

Magnetic Stress.—(See *Stress, Magnetic.*)

Magnetic Susceptibility.—(See *Susceptibility, Magnetic.*)

Magnetic Theodolite.—(See *Theodolite, Magnetic.*)

Magnetic Unit Pole.—(See *Pole, Unit, Magnetic.*)

Magnetic Units.—(See *Units, Magnetic.*)

Magnetic-Vane Ammeter.—(See *Ammeter, Magnetic-Vane.*)

Magnetic-Vane Voltmeter.—(See *Voltmeter, Magnetic-Vane.*)

Magnetic Variations.—(See *Variation, Magnetic.*)

Magnetic Variation Transit.—(See *Transit, Magnetic Variation.*)

Magnetic Variometer.—(See *Variometer, Magnetic.*)

Magnetic Viscosity.—(See *Viscosity, Magnetic.*)

Magnetic Whirl.—(See *Whirls, Magnetic.*)

Magnetic Whirl, Expanding — — (See *Whirl, Magnetic, Expanding.*)

Magnetics, Electro — — That branch of electric science which treats of the relations that exist between electric circuits and magnets.

Magnetism.—That branch of science which treats of the nature and properties of magnets and the magnetic field. (See *Field, Magnetic.*)

A property or condition of matter attended by the existence of a magnetic field.

Magnetism, Ampère's Theory of — — A theory or hypothesis proposed by Ampère, to account for the cause of magnetism, by the presence of electric currents in the ultimate particles of matter.

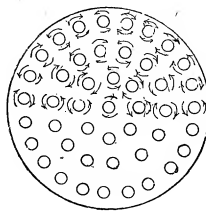

Fig. 379. Unmagnetized Bar (after Ampère).

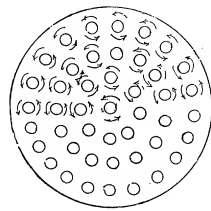

Fig. 380. Magnetized Bar (after Ampère).

This theory assumes:

(1.) That the ultimate particles of all magnetizable bodies have closed electric circuits in which electric currents are continually flowing.

(2.) That in an unmagnetized body these circuits neutralize one another because they have different directions.

(3.) That the act of magnetization consists in such a polarization of the particles as will cause these currents to flow in one and the same direction, *magnetic saturation* being reached when all the separate circuits are parallel to one another.

(4.) That *coercive force* is due to the resistance these circuits offer to a change in the direction of their planes.

Figs. 379 and 380 show the circular paths of some of these circuits. Fig. 379 shows the as-

sumed condition of an unmagnetized bar. Fig. 380 the assumed condition of a magnetized bar.

A careful inspection of the figures will show that in a magnetized bar all the separate currents flow in the same direction. *All the circuits except those on the extreme edge of the bar will, therefore, have the currents flowing in them in opposite directions to that in their neighboring circuits, and, therefore, will neutralize one another. There will remain, however, a current in a circuit on the outside of the bar, which must therefore be regarded as the magnetizing current.*

Guided by these considerations, Ampère produced a coil of wire, called a *solenoid*, which is the equivalent of the magnetizing circuit assumed by his theory.

It therefore follows that an electric current sent through a coil of insulated wire surrounding a rod or bar of soft iron, or other readily magnetizable material, will make the same a magnet. A magnet so produced is called an electro-magnet. (See *Magnet, Electro.*)

The magnetizing coil is called a helix or solenoid. (See *Solenoid, Electro-Magnetic.*)

The polarity of the magnet depends on the direction of the current, or on the direction of winding of the helix or solenoid. (See *Solenoid, Sinistrorsal. Solenoid, Dextrorsal.*)

The improbability of an electric current continually flowing in a circuit without the expenditure of energy, has led, perhaps, the majority of scientific men to reject Ampère's theory of magnetism.

Lodge, however, does not agree with the majority of physicists in regarding a constant flow of electricity through the molecules of magnetizable substances as an impossibility. On the supposition that the atoms or molecules possess no resistance, the current would flow through them forever. He says: "To all intents and purposes certainly atoms are infinitely elastic, and why should they not also be infinitely conducting? Why should the dissipation of energy occur, in respect to an electric current circulating wholly inside an atom? There is no reason why it should."

Magnetism, Animal — —A term sometimes applied to hypnotism or artificial somnambulism.

Magnetism, Earth's, Theories as to Cause of — —The various theories or hypotheses

respecting the cause of the earth's magnetism.

Any theory or hypothesis which shall satisfactorily explain the cause of the earth's magnetism must account for the following phenomena, viz.:

(1.) Variations in the intensity of the earth's magnetic field.

(2.) Variations in the earth's magnetic inclination, declination and intensity.

The following hypotheses have been proposed:

1st. That the earth's magnetism is due to the circulation round the earth of electric currents produced by differences of temperature which the earth's surface acquires from exposure to the sun during its rotation.

As the earth rotates from west to east, the area of greatest heat would move round the earth in the opposite direction, or from east to west. If now those differences of temperature could produce, in a manner not as yet explained, thermo-electric currents circulating round the earth from east to west, such currents would produce, in the Northern Hemisphere of the earth, south magnetic polarity, and in the Southern Hemisphere north magnetic polarity, which would account for the magnetic polarity of the earth.

Differences in the intensity of the earth's magnetic field, and in the inclination and direction of its lines of magnetic force, would be explained, according to this hypothesis, by the differences in the amount of the solar radiation at different times.

The objection to this theory is to be found in the fact that by far the larger part of the earth's surface at the Equator is composed of water, so that the differences of potential at such parts, produced by the differences of temperature, are not readily set up in the earth's crust, if, indeed, they are set up at all.

2d. That the earth's magnetism is due to induction from an already magnetized sun. This theory was brought forward by Secci and others. It is not generally credited.

3d. A theory proposed by Biglow, which accounts for the earth's magnetism by rotation in the magnetic field of the sun's light and radiation.

Biglow believes that the earth's magnetism is due to its rotation in the magnetic field of the sun's light. As the sun's light illumines one-half of the earth's surface, the earth's rotation causing different portions of the surface to pass through

this illumined area, produces, in Prof. Biglow's opinion, those differences in the direction and intensity of the magnetic lines of the earth's field that correspond to differences in the earth's magnetic intensity, declination and inclination.

It will be observed that in all these theories the sun is the prime factor in the production of the earth's magnetism.

The evident connection between the earth's magnetism and the solar radiation is established from the well known connection between the so-called magnetic storms and variations in the intensity of the earth's magnetism.

Magnetic storms are always attended by outbursts of solar energy, known technically as sun-spots. A series of observations on the numbers and frequency of sun-spots, plotted in the form of a curve, the ordinates of which represent the times of occurrence of the spots and the abscissas, the number of such spots, prove that such curve agrees, in a remarkable manner, with a similar curve representing the variations of the earth's magnetic field.

An evident connection, too, exists between the earth's magnetism and the prevalence of the aurora borealis.

Magnetism, Electro — —Magnetism produced by means of electric currents.

The discovery by Oersted, in 1820, of the action of an electric current on a magnetic needle, was almost immediately followed by the simultaneous and independent discoveries by Arago and Davy, of the method of magnetizing iron by the passage of an electric current around it.

These observations were first reduced to a theory by Ampère. (See *Magnetism, Ampère's Theory of. Magnet, Electro.*)

Magnetism, Ewing's Theory of — —A theory of magnetism proposed by Prof. Ewing, based on the assumption of originally magnetized particles.

Ewing's theory of magnetism assumes that the ultimate particles of matter are naturally magnetic and possess polarity. In this respect Ewing's theory agrees with the theories of Hughes and Weber. Ewing does not believe, however, in the necessity for the assumption of any arbitrary restraining or constraining force to the movements of these ultimate magnetic particles other than those due to their own mutual magnetic attractions and repulsions. He assumes that in a magnet,

the centres about which the molecular magnets rotate are maintained at constant distances from one another, save only as they are affected by the action of strain.

He has experimentally demonstrated the principles of his theory by means of a model in which a number of small magnetic needles are so supported as to be capable of free motion in a horizontal plane, when under varying magnetic forces.

According to Ewing, "magnetic hysteresis" is not the result of any quasi-frictional resistance to molecular rotation, but arises from a molecule moving from one position of stable equilibrium to another position of stable equilibrium through a position of unstable equilibrium. "This process," says Ewing, "considered mechanically, is not reversible. The forces are different for the same displacement, going and coming, and there is dissipation of energy. In the model, the energy thus expended sets the little bars swinging, and their swings take some time to subside. In the actual solid, the energy which the molecular magnet loses as it swings through unstable positions, generates eddy currents in surrounding matter. Let the magnets of the model be furnished with air vanes to damp their swings and the correspondence is complete."

In Hughes' modification of Weber's theory of magnetism, it was held, that when magnetized iron was suddenly demagnetized by torsion or flexure, it lost its magnetization because the molecular magnets came to rest in closed chains, which produced no external effects. Experimentation with Ewing's model of a magnet shows that when the separate magnets after having been placed in any particular grouping are permitted to come to rest free from any external magnetic force, they do not arrange themselves in closed chains, but in general the tendency appears to be the formation of lines consisting of two, three or more magnets each member of a line being strongly controlled by its next member in that line, but influenced by the neighbors which lie off the line on either side.

The fact that a given force, suddenly applied, produces more magnetic induction than when gradually applied, and leaves less residual magnetism when suddenly than when gradually removed, is presumably due to the inertia of the molecules.

The influence of mechanical vibration in increasing the magnetic susceptibility and decreas-

ing the magnetic retentiveness, is ascribed by Ewing to the fact that the vibrations cause periodic variations in the distances between the centres of rotation of the magnetic molecules; thus making the molecular magnets respond more readily to changes of magnetic force during the time they are moving away from one another, when their magnetic stability is less, but also increasing the ease with which they respond to changes of magnetic force, by causing them to swing.

Ewing discusses the theoretical effects of temperature on magnetism as follows, viz.: Suppose a moderate magnetizing force to be applied so that nothing like saturation is obtained, if now the temperature be raised; then

(1.) The magnetic permeability increases until the temperature reaches a certain (high) critical value.

(2.) At this temperature there is suddenly an almost complete disappearance of magnetic quality.

He explains these facts as follows, viz.: An increase of temperature by increasing the distance between the molecular centres causes a decrease in their stability.

The loss of magnetic qualities, when a certain temperature is reached, is, he believes, due to the fact that at such temperatures the magnetic molecules are set into actual rotation, when, naturally, all traces of polarity would disappear.

Ewing's theory of magnetism also accounts to a considerable extent for the effects of stress and consequent elastic strain on the magnetic qualities of iron, nickel and cobalt.

The following general summary of his theory is taken mainly from Prof. Ewing's original articles as published in the *Journal of the Society of Arts*:

(1.) That in considering the magnetization of iron and other magnetic metals to be caused by the turning of permanent molecular magnets, we may look simply to the magnetic forces which the molecular magnets exert upon one another as the cause of their directional stability. There is no need to suppose the existence of any quasi-elastic directing force, or any quasi-frictional resistance to rotation.

(2.) That the intermolecular magnetic forces are sufficient to account for all the general characteristics of the process of magnetization, including the variations of susceptibility which occur as the magnetizing force is increased.

(3.) That the intermolecular magnetic forces are equally competent to account for the known facts of retentiveness and coercive force, and the characteristics of cyclic magnetic processes.

(4.) The magnetic hysteresis and the dissipation of energy which hysteresis involves are due to molecular instability, resulting from intermolecular magnetic actions, and are not due to anything in the nature of frictional resistance to the rotation of the molecular magnets.

(5.) That this theory is wide enough to admit an explanation of the differences in magnetic quality which are shown by different substances, or by the same substance in different states.

(6.) That it accounts in a general way for the known effects of vibration, of temperature, and of stress, upon magnetic quality.

(7.) That, in particular, it accounts for the known fact that there is hysteresis in the relation of magnetism to stress.

(8.) That it further explains why there is in magnetic metals hysteresis in physical quality generally with respect to stress.

(9.) That, in consequence, any (not very small) cycle of stress occurring in a magnetic metal involves dissipation of energy.

It can be demonstrated by means of experiments with a model constructed according to Ewing's hypothesis, that this hypothesis comes nearer than any which had been proposed before in explaining the following effects:

(1.) The behavior of a piece of iron when placed in a magnetic field whose strength is made to pass through a cycle of changes.

(2.) That nearly all reversals of sign on the change of the magnetizing force are accompanied by small changes in the magnetization.

(3.) That a piece of iron submitted to vibrations or mechanical shocks, is magnetized and demagnetized more readily and with a smaller hysteresial area than if it had remained undisturbed by vibrations.

(4.) The phenomenon of "time lag" in magnetization.

(5.) The phenomena of stress, both those which occur when a body has first been placed in a magnetic field and the stress made to vary, and those which occur when a body is first placed in a constant stress and the magnetizing force is made to vary.

(6.) The effects of heat on magnetization, both as regards the effect of comparatively low heating on increase of magnetic susceptibility, and the

quently magnetized it was found to be much more powerful in comparison to its size than any other magnet.

Mr. Shelford Bidwell has shown that the act of magnetization produces a shortening rather than a lengthening of the magnetizable material. When the magnetization is moderate there is a true lengthening of the material, but when a more powerful magnetizing force is exerted a true contraction or shortening is observed.

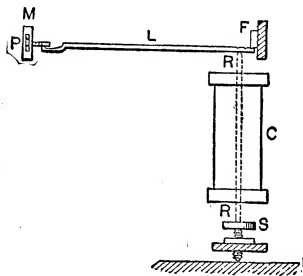

Fig. 383. Bidwell Apparatus.

The Bidwell apparatus is shown in Fig. 383. The bar of iron to be magnetized is shown at R R. The magnetization is obtained by means of the coil of wire C. The upper end of the bar presses against the rod L, fulcrumed at F. The other end of the bar bears against a pivoted mirror M, from which a spot of light is reflected.

In the case of the magnetization of nickel, the experiments of Bidwell showed the existence of contraction for both weak and strong currents. This contraction is much greater than in the case of iron.

Magnetism, Lamellar Distribution of

—The distribution of magnetism in magnetic shells.

A term sometimes applied to such a distribution of magnetism in a plate, that the magnetized particles are arranged with their greatest length in the direction of the thickness of the plate, so that the poles are situated at the faces of the plate, and consequently the extent of such polar surfaces is great when compared with the thickness of the plate.

The term lamellar distribution of magnetism is used in contradistinction to solenoidal distribution. (See *Magnetism, Solenoidal Distribution of.*)

A thin sheet or disc of magnetized material whose opposed extended faces are of opposite

magnetic polarities, and the extent of whose surface is very great as compared with its thickness, is sometimes called a *magnetic shell*.

The field produced by a magnetic shell is exactly similar to that produced by a closed voltaic circuit, the edges of the space inclosed by which correspond to the edges of the magnetic shell.

The magnetic intensity, or the number of lines of force per unit area of cross-section, is equal over all parts of the surface of a simple magnetic shell.

A magnetic shell may be conceived as consisting of a very great number of short, straight magnetic needles, placed side by side, with their north poles terminating at one of the faces of the sheet and their south poles at the opposite face, the breadth of the sheet being very great as compared with its thickness. Such a distribution of magnetism is known as a *lamellar distribution*.

Magnetism, Residual —The magnetism remaining in the core of an electro-magnet on the opening of the magnetizing circuit.

The small amount of magnetism retained by soft iron when removed from any magnetizing field.

When hard iron or steel is removed from a magnetizing field it retains nearly all its magnetism. Such magnetism is also, in reality, residual magnetism, but the term is generally limited to the case of soft iron.

Magnetism, Solenoidal Distribution of

—A term sometimes applied to such a distribution of magnetism in a bar that the magnetized particles are arranged with their poles in the direction of the length of the bar, the ends of which are of opposite magnetic polarities, and the extent of whose surfaces is small as compared with the length of the bar.

The term solenoidal distribution is used in contradistinction to lamellar distribution. (See *Magnetism, Lamellar Distribution of.*)

Magnetism, Strength of —A term sometimes used in the sense of intensity of magnetization. (See *Magnetization, Intensity of.*)

The term, strength of magnetism, is sometimes used for flux or quantity of magnetism.

Intensity of magnetization, is the preferable term.

Magnetism, Terrestrial — —A name applied to the magnetism of the earth.

Terrestrial magnetism has been ascribed to a variety of causes. (See *Magnetism, Earth's, Theories as to Cause of.*)

Magnetism, Vertical Component of Earth's — —(See *Component, Vertical, of Earth's Magnetism.*)

Magnetite.—Magnetic oxide of iron, or Fe_3O_4 , found in nature, as an ore or mineral.

Lo³e-stone consists of pieces of magnetized magnetite.

Magnetizable.—Capable of being magnetized after the manner of a paramagnetic substance like iron.

The most magnetizable metals are iron, nickel, cobalt and manganese. (See *Paramagnetism.*)

Magnetization.—The act of calling out or of endowing with magnetic properties.

Magnetizable substances are magnetized by being placed in magnetic fields. (See *Field, Magnetic. Magnetization, Methods of.*)

The act of initial magnetization is not exactly the same as the act of subsequent magnetization.

A piece of steel, which has once been magnetized and subsequently demagnetized, is a thing entirely distinct, as regards its magnetization, from a piece of steel which has never before been magnetized, and such a piece can never be placed exactly in the same position as regards a magnetizing force, unless it is actually melted and recast, or, perhaps, maintained for a comparatively long time at a white heat.

Magnetization, Anomalous — —The magnetization obtained from an oscillatory discharge, such as that of a Leyden jar.

In 1842, Henry described the real character of anomalous magnetization, and showed that there was nothing anomalous in such magnetization, but rather in the fact that the magnetizing currents possessed no simple direction. He remarks on this subject as follows:

“This anomaly, which has remained so long unexplained, and which, at first sight, appears at variance with all our theoretical ideas of the connection of electricity and magnetism, was, after considerable study, satisfactorily referred to an action of the discharge of a Leyden jar which had never before been recognized. The discharge,

whatever may be its nature, is not correctly represented (employing the simplicity of Franklin) by the single transfer of an imponderable fluid from one side of the jar to the other; the phenomena require us to admit the existence of a principal discharge in one direction and then several reflex actions backward and forward, each more feeble than the preceding, until the equilibrium is obtained. All the facts are shown to be in accordance with the hypothesis, and a ready explanation is afforded by it of a number of phenomena which are to be found in the older works on electricity, but which have until this time remained unexplained.”

Magnetization by Touch.—The production of magnetism in a magnetizable substance by touching it with a magnet.

There are three methods of magnetization by touch, viz.:

- (1.) Single touch.
- (2.) Separate touch.
- (3.) Double touch.

In single touch, the magnetization of a bar of iron or other magnetizable material is effected by the touch of a single magnet.

In Single Touch, the magnetizing magnet is drawn over the bar to be magnetized from end to end and returned through air, the stroke being repeated a number of times. The end of the bar the magnet leaves is magnetized oppositely to the magnetizing pole.

By some writers the method of single touch is described as that effected by placing the magnetizing magnet NS (Fig. 384) on the middle of the bar to be magnetized, and drawing it to the end and returning through the air as before, and then reversing the pole, placing it on the middle of the bar and drawing it towards the other end. The

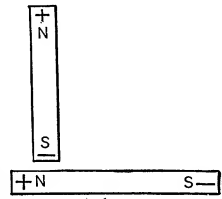

Fig. 384. Magnetization by Single Touch.

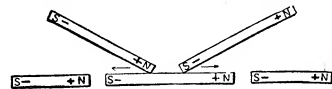

Fig. 385. Magnetization by Separate Touch.

former would, however, appear to be the better use of the term single touch.

In Separate Touch, two magnetizing bars are placed with their opposite poles at the middle

of the bar to be magnetized and drawn away from each other towards its ends, as shown in Fig. 385. This motion is repeated a number of times, the poles being each time returned through the air.

In the above, as in all cases of magnetization by touch, better effects are produced, if the bar

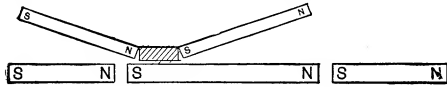

Fig. 386. Magnetization by Double Touch.

to be magnetized is rested on the opposite poles of another magnet, or, as shown in Fig. 386, placed near them.

In Double Touch the two magnets are placed with their opposite poles together on the middle of the bar to be magnetized, as shown in Fig. 386. They are then moved to one end of the bar, when, instead of removing them and passing them back through the air to the other end, they are moved over the surface of the bar to be magnetized to the other end, and these to-and-fro motions are repeated a number of times. The motion is stopped at the middle of the bar, when the magnetizing magnets are moving in the opposite direction to that at which they began to move. This insures an equal number of strokes to the two halves of the bar. The method of double touch produces stronger magnetization than either of the other methods, but does not effect such an even distribution of the magnetism, and therefore is not applicable to the magnetization of needles.

A variety of double touch is shown in Fig. 387, where four bars, to be magnetized, are placed in the form of a hollow rectangle, with only their ends touching at their edges, the angular spaces

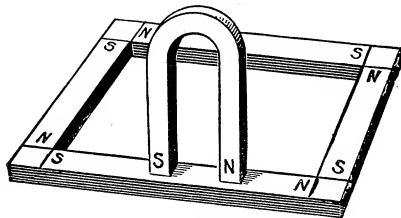

Fig. 387. Magnetization by Double Touch.

at the corners being filled with pieces of soft iron. The horseshoe magnet NS, is then moved around the circuit several times in the same direction. This is believed to produce a more uniform mag-

netization than the ordinary method of double touch.

Magnetization, Co-efficient of — A number representing the intensity of magnetization produced in a magnetizable body, divided by the magnetizing force H.

Calling k, the co-efficient of magnetization; I, the intensity of the resulting magnetization, and H, the magnetizing force producing it, then

$$k = \frac{I}{H}.$$

The co-efficient of magnetization is sometimes called the magnetic susceptibility.

A paramagnetic body when placed in a magnetic field concentrates the lines of magnetic force on it, or causes them to pass through it. The intensity of the magnetization so produced depends, therefore,

- (1.) On the intensity of the magnetizing field.
- (2.) On the ability of the metal to concentrate the lines of force on it; that is, on the nature of the metal, or on its magnetic permeability. (See *Permeability, Magnetic. Paramagnetism. Diamagnetism.*)

The intensity of magnetization will, therefore, be equal to the product of the co-efficient of magnetization and the intensity of the magnetizing field. It will, also, of course, depend on the area of cross-section of the magnetized body.

The co-efficient of magnetization of paramagnetic bodies is said to be positive, and that of diamagnetic bodies to be negative, because paramagnetic bodies concentrate the lines of magnetic force on them, while diamagnetic bodies appear to repel the lines of force. (See *Paramagnetic. Diamagnetic.*)

Magnetization, Critical Current of — The current at which any certain or definite effect of magnetization is produced.

Magnetization, Intensity of — A quantity showing the intensity of the magnetization produced in a substance.

A quantity showing the intensity with which a magnetizable substance is magnetized.

The intensity of magnetization depends:

- (1.) On the intensity of the magnetizing field.
- (2.) On the magnetic permeability, or on the conducting power of the substance for lines of magnetic force.

The greater the strength of the magnetizing field, and the greater the magnetic permeability, the greater is the intensity of the magnetization produced.

When, therefore, a magnetizable substance is placed in a magnetizing field, the intensity of the magnetization will depend on the magnetic susceptibility of the substance; that is, on the ratio of the induced magnetization to the magnetizing force producing it.

Soft iron has a high co-efficient of magnetization, or its magnetic susceptibility is high. (See *Susceptibility, Magnetic. Magnetization, Co-efficient of.*)

The intensity of magnetization through a substance is measured by dividing the magnetic moment by the magnetic volume.

If a bar of soft iron is placed with its greatest length extending in the direction of the lines of force in a magnetic field, it will have induced in it a certain intensity of magnetization which may be expressed as follows:

$$\text{Intensity of Magnetization} = \frac{m \cdot l}{\text{Volume}} = k H,$$

where m , equals the strength of the magnet; l , its length; k , the co-efficient of magnetization, and H , the intensity of the magnetizing field.—(*S. P. Thompson.*)

“The moment of a magnet, or of any element of a magnet, may be considered numerically to be made up of two factors, one, its volume, and the other its *intensity of magnetization*, or simply its *magnetization*, and hence, for a uniformly magnetized small linear needle, we may define the intensity of its magnetization by saying that it has magnetic moment of unit volume.”—(*Fleming.*)

Magnetization, Maximum — —A term sometimes used for magnetic saturation.

Urquhart states, as the result of numerous experiments, that the number of lines of magnetic force that usually pass through a bar of soft iron 1 square centimetre in area of cross-section, when magnetized to a maximum, is equal to 32,000. Ewing gives the number in the particular case of a very extraordinary magnetization as being equal to 45,350 per square centimetre area of cross-section.

Magnetization, Methods of — —Magnetization effected either by induction from another magnet, or by means of induction by an electric current.

The substance to be magnetized is brought into a magnetic field, so that the lines of magnetic force pass through it. All methods of magnetization may be divided into methods of *magnetization by touch* and *magnetization by the electric current*. (See *Magnetization by Touch.*)

Magnetization, Permanent, Intensity of — —A term employed for the intensity of a permanent magnetization produced in hard steel, as distinguished from the magnetization temporarily produced in soft iron. (See *Magnetization, Intensity of.*)

Magnetization, Temporary, Intensity of — —The intensity of the magnetization temporarily induced in a bar of soft iron, as distinguished from permanent magnetization induced in hard steel. (See *Magnetization, Intensity of.*)

Magnetization, Time-Lag of — —A lag which appears to exist between the time of action of the magnetizing force and the appearance of the magnetism.

The time which must elapse in the case of a given paramagnetic substance before a magnetizing force can produce magnetization.

In the opinion of some physicists there is no such thing as a true magnetic time-lag, the apparent time-lag being due entirely either to hysteresis or to eddy currents. According to them, while the magnetizing force is increasing, it produces, in the iron, reversely-directed surface-eddy-currents, which produce a reversed or opposed magnetizing force in the more deeply seated layers of the iron, the time-lag being due to the interval which is required for these eddy currents to die away and thus permit the magnetizing force to produce its full magnetization.

According to others, however, a true time-lag does exist entirely apart from the existence of surface-eddy-currents.

Magnetize.—To endow with magnetic properties.

Magnetized.—Endowed or impressed with magnetic properties.

Magnetizing.—Causing or producing magnetism.

Magneto-Blasting Machine.—(See *Machine, Magneto-Blasting.*)

Magneto-Electric Bell.—(See *Bell, Magneto-Electric.*)

Magneto-Electric Brake.—(See *Brake, Magneto-Electric.*)

Magneto-Electric Call-Bell.—(See *Call-Bell, Magneto-Electric.*)

Magneto-Electric Faradic Apparatus.—(See *Apparatus, Faradic, Magneto-Electric.*)

Magneto-Electric Induction.—(See *Induction, Magneto-Electric.*)

Magneto-Electric Machine.—(See *Machine, Magneto-Electric.*)

Magneto-Electric Medical Apparatus.—(See *Apparatus, Magneto-Electric Medical.*)

Magneto-Electricity.—(See *Electricity, Magneto.*)

Magnetograph.—The permanent record obtained from the action of a self-recording magnetometer. (See *Magnetometer, Self-Recording.*)

Magnetometer.—An apparatus for the measurement of magnetic force.

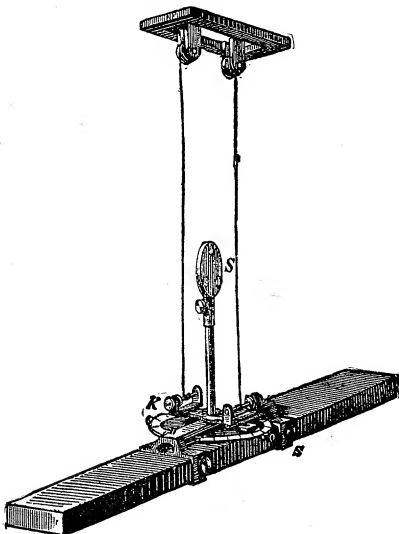

Fig 388. Magnetometer.

In some magnetometers the magnetic force is measured by the torsion of a wire, as in the *torsion balance*. (See *Balance, Coulomb's Torsion.*)

The magnetometer shown in Fig. 388, consists of a magnetized bar suspended by two wires passing over a pulley, as shown. The magnet is held by the frame S S, provided with a graduated scale K. The mirror S, is supported by a vertical post attached to the frame, and serves to reflect a scale placed below a distant reading telescope. This form of magnetometer, is called the bifilar magnetometer, and was the one used by Gauss in his study of the earth's magnetism.

A variety of forms have been given to delicate magnetometers. Some are self-recording. (See *Magnetometer, Self-Recording.*)

Magnetometer, Differential — — A form of magnetometer in which the principles of the differential galvanometer, as applied to the electric circuit, are applied to the magnetic circuit.

The differential magnetometer of Eickemeyer is shown in Figs. 389 and 390. Its principles of operation will be understood from the following considerations.

Referring to Fig. 389. Suppose F_1 and F_2 are two electromotive forces connected in series, and x and y , two resistances to be compared. Each of the resistances x and y , is shunted respectively by two conductors a and b , whose resistance we wish to compare. Since the action of each of them on the galvanometer G , is opposite, its needle remains at zero, when the current in a , is equal to the current in b .

If, instead of electric circuit, we take the idea of magnetic circuit or the number of lines of magnetic force, and instead of potential difference,

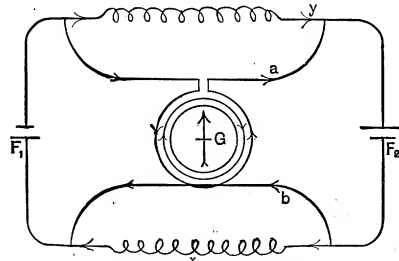

Fig. 389. Eickemeyer's Differential Magnetometer.

magneto-motive force, and instead of electric resistance, magnetic resistance, we have the principles on which the Eickemeyer differential magnetometer is founded.

The magnetic circuit of the differential magnetometer consists of two pieces of soft iron, shaped

as shown at F_1 and F_2 , Fig. 390. A magnetic coil C, surrounds the middle portion of each circuit as shown. The operation as described by Mr. Chas. Steinmetz, from whom the above description is mainly taken, is as follows, viz.: "The front part s_1 of the left iron piece becomes south, and the back part n_1 north polarity; the front part of the right iron piece n_2 becomes north, and the back part south; and the lines of magnetic force travel in the front from the right to the left, from n_2 to s_1 ; in the back the opposite way, from the left to the right, or from n_1 to s_2 , either through the air, or, when n_2 and s_1 , or n_1 and s_2 , are connected by a piece of magnetizable metal, through this and through the air.

In the middle of the coil C, stands a small soft iron needle with an aluminum indicator, which plays over a scale K, and is held in a vertical position by the lines of magnetic force of the coil C, itself, deflected to the left by the lines of magnetic force traversing the front part of the instrument from n_2 to s_1 , deflected to the right by the lines traversing the back from n_1 to s_2 . This needle shows by its zero position that the magnetic flow through the air in front from n_2 to s_1 has the same strength as the magnetic flow in the back from n_1 to s_2 through the air.

Now we put a piece of soft iron x on the front of the instrument. A large number of lines go through x, less through the air from n_2 to s_1 ; but all these lines go from n_1 to s_2 through the air at the back part of the magnetometer, the front part and back part of the instrument being connected in series in the magnetic circuit. Therefore the needle is deflected to the right by the magnetic flow in the back of the instrument.

Now, we put another piece of iron, y, on the back part of the instrument, then equilibrium would be restored as soon as the same number of lines of magnetic force go through x, as through y, because then also the same number of lines go through air in the front as in the back. As will be noted, the air here takes the place of the resistances a and b, influencing the galvanometer needle G, as in the diagram Fig. 389.

The operation of the instrument is exceedingly simple and is as follows: Into the coil C, an electric current is sent which is measured by the ammeter A, and regulated by the resistance-switch R. Then the needle, which before had no fixed position, points to zero.

Now, we lay the piece of iron, the magnetic properties of which we want to determine, on the

back part of the instrument. The needle is deflected to the left. On the front of the instrument we put Norway iron rods of known cross-section and known conductivity, until equilibrium is again restored. Then the iron in the front has the same magnetic resistance as the iron in the back, and the ratio of the cross-sections gives directly the ratio of the conductivities; so that by a single reading the magnetic conductivity of any piece of iron can be compared with that of the Norway iron standard.

For absolute determinations, the iron is turned off into pieces of exactly 4 square centimetres cross-section and 20 centimetres in length, both ends fitting into holes in large blocks of Norway iron, which are laid against the pole pieces of the magnetometer, so that the transient resistance from pole face to iron is eliminated.

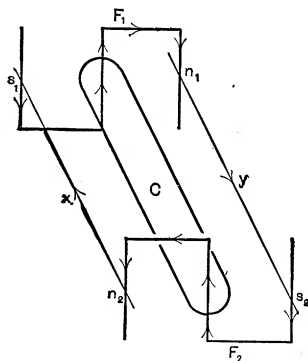

Fig. 390. Eickemeyer's Differential Magnetometer.

Magnetometer, Self-Recording — — A self-recording apparatus, by means of which the daily and hourly variations of magnetic needles in the earth's field, at any locality, are continuously registered.

The self-recording magnetometer employed in the observatory at Kew, consists essentially of means of obtaining a photographic record of a spot of light reflected from a mirror, attached to the needle whose variations are to be recorded. The photographic record is received on a strip of sensitized paper, maintained in uniform and continuous motion by means of suitable clock-work. The record so obtained is called a magnetograph.

Magneto-Motive Force. — (See *Force, Magneto-Motive*.)

Magneto-Motive Force, Absolute Unit of — —(See *Force, Magneto-Motive, Absolute Unit of*.)

Magneto-Motive Force, Practical Unit of — —(See *Force, Magneto-Motive, Practical Unit of*.)

Magneto-Optic Rotation.—(See *Rotation, Magneto-Optic*.)

Magnetophone.—A species of magnetic siren in which sounds are produced in an electro-magnetic telephone by the periodic currents produced in its coils by the rotation of a perforated metallic disc in a magnetic field.

As the speed of the disc increases, the pitch of the note increases. The apparatus was invented by Prof. Carhart, in 1883. A similar apparatus is useful in studying the distribution of the magnetic field of a dynamo-electric machine. In this case, a small, thin coil of insulated wire is held in the different regions around the machine, while the telephone is held to the ear of the observer. Magnetic leakage, or useless dissipation of lines of magnetic force outside the field proper of the machine, is at once rendered manifest by the musical note caused by variations in the intensity of the field.

Since the intensity of the note heard will vary according to the intensity of the field, and also according to the position in which the coil is held, such a coil becomes a *magnetic explorer*, and by its use the distribution and varying intensity of an irregular field can be ascertained. Its use is especially advantageous in proportioning dynamo-electric machines and electric motors. (See *Explorer, Magnetic*.)

Magneto-Receptive Device.—(See *Device, Magneto-Receptive*.)

Magneto-Static Current Meter. — (See *Meter, Current, Magneto-Static*.)

Magneto-Static Screening.—(See *Screening, Magneto-Static*.)

Magneto-Statics.—(See *Statics, Magneto*.)

Magneto-Therapy.—(See *Therapy, Magneto*.)

Main Battery.—(See *Battery, Main*.)

Main-Battery Circuit.—(See *Circuit, Main-Battery*.)

Main, Electric — —The principal conductor in any system of electric distribution.

Main Feeder.—(See *Feeder, Standard or Main*.)

Main Fuse.—(See *Fuse, Main*.)

Main, House — —A term employed in a system of multiple incandescent lamp distribution for the conductor connecting the house service conductors with a centre of distribution, or with a street main.

Main-Line Cut-Out.—(See *Cut-Out, Main-Line*.)

Main, Street — —In a system of incandescent lamp distribution the conductors extending in a system of networks through the streets from junction box to junction box, through which the current is distributed from the feeder ends, through cut-outs, to the district to be lighted, and from which service wires are taken.

Main, Sub — —A name sometimes given to the distributing conductor that is connected directly to a main.

The branch nearest the main. (See *Branch*.)

Main Wire.—(See *Wire, Main*.)

Mains of Electric Railroads.—The wires or conductors used for carrying the current from the feeders through the tap wires to the trolley wires.

Make.—A completion of a circuit.

Make-and-Break.—The periodic alternate completion and opening of a circuit.

Make-and-Break, Automatic — —A term sometimes employed for such a combination of contact points with the armature of any electro-magnet, that the circuit is automatically made and broken with great rapidity.

An automatic make-and-break is used in most forms of electric alarms in connection with some form of electric bell. (See *Alarm, Electric*.)

It is also used in the Ruhmkorff induction coil in order to produce the variations in the primary circuit. (See *Coil, Induction*.)

Make-Induced Current.—(See *Current, Make-Induced*.)

Making the Primary.—(See *Primary, Making the.*)

Mallet, Electro-Magnetic Dental —
—(See *Dental-Mallet, Electro-Magnetic.*)

Mangin Projector.—(See *Projector, Mangin.*)

Man-Hole, Compartment, of Conduit —
—A man-hole provided with suitably supported shelves or compartments, guarded by locked doors that protect different cable sections.

Man-Hole of Conduit.—An opening of sufficient size to admit a man, communicating from the surface of the roadbed with an underground conduit.

Manipulator, Breguet's — —The sending instrument employed by Breguet in his system of step-by-step or dial telegraphy. (See *Telegraphy, Step-by-Step.*)

Manometer.—An apparatus for measuring the tension or pressure of gases.

Manometers are either mercurial or metallic. Mercurial manometers are of two classes, viz., manometers with free air and manometers with compressed air.

Manometers measure the pressure of gases either in atmospheres, *i. e.*, in multiples or decimals of 15 pounds to the square inch, or in inches of mercury.

Map or Chart, Inclination — —A chart or map on which lines are drawn, showing the lines of equal dip or inclination, or the isoclinic lines.

An *inclination chart* is shown in Fig. 391.

It will be seen that the magnetic equator, or line of no dip, does not correspond with the geographical equator, being generally north of the equator in the Eastern Hemisphere, and south of it in the Western. The figures attached to the lines indicate the value of the angle of dip.

Map or Chart, Isodynamic — —A map of the earth on a mercator's projection, on which isodynamic lines are drawn.

An isodynamic chart is shown in Fig. 392. It will be observed that the *isodynamic lines* do not exactly coincide with the *isoclinic lines*, since the line of least magnetic intensity does not correspond with the line of the magnetic equator.

The point of *least magnetic intensity* is found at

about lat. 20 degrees S., and lon. 35 degrees W. The point of *greatest magnetic intensity* is found at about lat. 52 degrees N. and lon. 92 degrees W.

Another, though weaker point of magnetic intensity, is found in Siberia. These are distinguished from the true magnetic poles by the term *Poles of Intensity*.

The *Poles of Verticity*, as determined by the *dipping needle*, and the *Poles of Intensity*, as determined by the *needle of oscillation*, therefore do not coincide in the Northern Hemisphere.

Map or Chart, Isogonal — —A term sometimes used for an isogonic map or chart.

Map or Chart, Isogonic — —A chart on which the isogonic lines are marked.

An isogonic map or chart is sometimes called a declination map or chart.

In the declination or variation chart, shown in Fig. 393, the region of western declination is indicated by the shading. There is a remarkable oval patch in the northeastern part of Asia, in which the declination is west. A similar oval of decreased inclination is seen in the Southern Pacific.

The entire earth acts like a huge magnet with south magnetic polarity in the Northern Hemisphere.

It is not known whether the earth possesses but a single pair of magnetic poles or more than a single pair. The variations in the declination, and in the intensity of its magnetism, due to the position of the sun, as well as the marked magnetic disturbances that accompany the occurrence of sun spots, would appear to connect the earth's magnetism in some manner with the solar radiation. (See *Magnetism, Earth's, Theories as to Cause of.*)

Marine Galvanometer.—(See *Galvanometer, Marine.*)

Mariner's Compass.—(See *Compass, Azimuth.*)

Marked Pole of Magnet.—(See *Magnet, Marked Pole of.*)

Markers.—Colored flags, or signal lights, generally green, displayed in systems of block railway signaling at the ends of trains, in order to avoid accidents from trains breaking in two. (See *Railroads, Block System for.*)

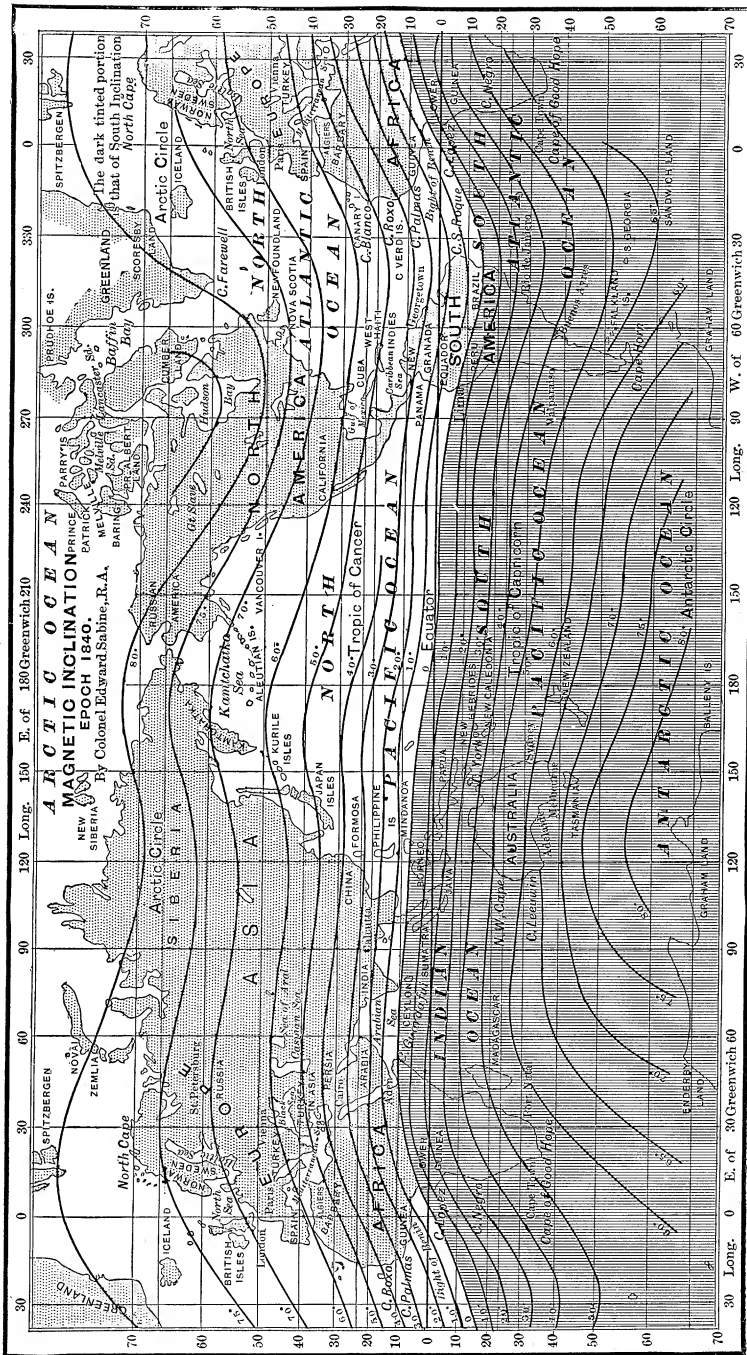

Fig. 391. Inclination Chart.

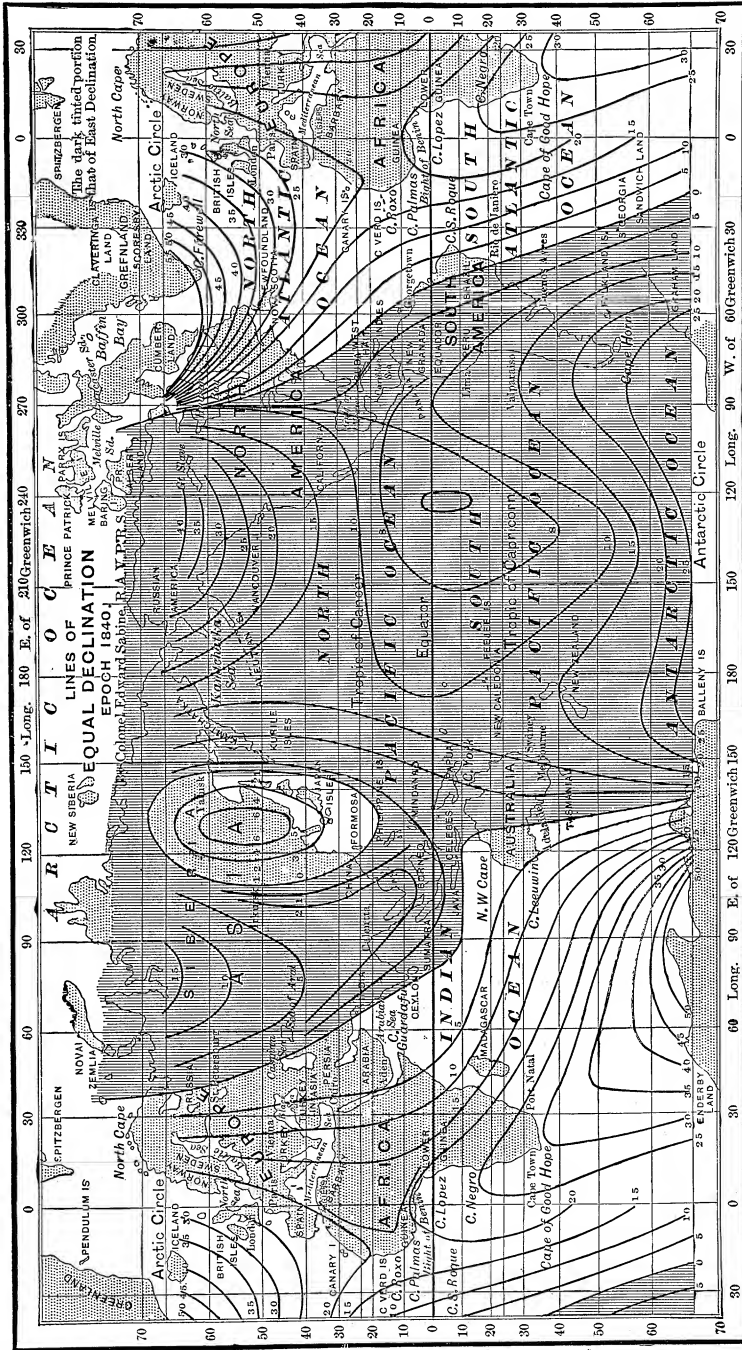

Fig. 393. Isogonic Chart.

Mass.—The quantity of matter contained in a body.

Mass must be carefully distinguished from *weight*. The weight of a given quantity of matter depends on the attraction which the earth possesses for it, and this, on the earth's surface, varies with the latitude, being greatest at the poles and least at the equator. It also varies with different elevations above the level of the sea. The *mass*, however, is the same under all circumstances, whether for different latitudes or altitudes, on the earth's surface.

Mass Attraction.—(See *Attraction, Mass.*)

Mass, Magnetic — —A quantity of magnetism which at unit distance produces an action equal to unit force.

Mass, Unit of — —The quantity of matter which under certain conditions will balance the weight of a standard gramme or pound.

The gramme is equal to the one-thousandth part of a piece of platinum called the kilogramme, deposited as a standard in the archives of the French Government, and intended to be equal to the mass of 1 cubic centimetre of water at the temperature of its maximum density.

Massage.—A treatment for the purpose of effecting changes in general nutrition or action of particular parts of the body, by kneading, rubbing, friction, etc.

Massage, Electro — —The application of electricity to the body during its massage.

Connections are established between the patient and a battery by connecting one electrode of a source to the kneading instrument, and the other electrode to the body of the patient.

Masses, Electric — —A mathematical conception for such quantities of electricity as at unit distance will produce an attraction or repulsion equal to unit force.

Electrical masses are assumed to be equal when they produce on two identical bodies of small dimensions charges of the same electric force.

Master Clock.—(See *Clock, Master.*)

Materials, Insulating — —Non-conducting substances which are placed around a conductor, in order that it may either retain an electric charge, or permit the passage of

an electric current through the conductor without sensible leakage.

Various gases, liquids or solids may be employed as insulators. A very high vacuum affords the best known insulation.

Matter.—Anything which occupies space in three directions and prevents other matter from simultaneously occupying the same space.

Matter is composed of *atoms*, which unite to form *molecules*. (See *Atom. Molecule.*)

Matter, Elementary — —Matter which cannot be decomposed into simpler matter.

Varieties of elementary matter are called *elements*. (See *Element.*)

Matter, Kinetic Theory of — —A theory which assumes that the molecules of matter are in a constant state of motion or vibration towards or from one another in paths that lie within the spheres of their mutual attractions or repulsions.

The molecules of gases have great freedom of motion, and are so far removed from one another as to be but little, if any, influenced by their mutual attractions. They are therefore assumed to move in straight lines with very great velocity until they collide against one another, or against the sides of the containing vessel, when they are reflected and again move in straight lines in a new path.

Matter, Radiant, or Ultra-Gaseous — —A term proposed by Crookes for the peculiar condition of the gaseous matter which constitutes the residual atmospheres of high vacua.

This is now generally recognized as a fourth state of matter, these four states being:

- (1.) Solid.
- (2.) Liquid.
- (3.) Gaseous.
- (4.) Ultra-gaseous or radiant.

The peculiar properties of radiant matter are seen in the mechanical effects of the localized pressures produced when such residual atmospheres are locally heated or electrified.

In *Crookes' radiometer*, vanes of mica, silvered on one face and covered with lampblack on the opposite face, are supported on a vertical axis so as to be capable of rotation and placed in a glass vessel in which a *high vacuum* is maintained. On

exposing the instrument to the radiation from a candle or gas flame, a rapid rotation takes place. (See *Radiometer, Crookes'*.)

The explanation is as follows: The lampblack covered surfaces absorb the radiant heat, and becoming heated, the molecules of gas in the residual atmosphere are shot violently from them, and by their reaction drive the vanes around in the opposite direction to that from which they are thrown off. The molecules are also shot off from the silvered surfaces, but, as these are cooler, the effect is not as great as at the blackened surfaces.

In a gas, at ordinary pressure, the heated surfaces are also bombarded by other molecules of the gas, but in high vacua the mean free path of the molecules is so great that there is no interference, a *Crookes' layer* existing between the vanes and the walls of the glass vessel. (See *Layer, Crookes'*.)

When a Crookes' tube is furnished with suitable electrodes, and electric discharges are sent through it between these electrodes, a stream of molecules is thrown off in straight lines from the surface of the negative electrode.

Some of the effects of this *molecular bombardment* are seen by the use of the apparatus shown in Fig. 394. When the positive and negative

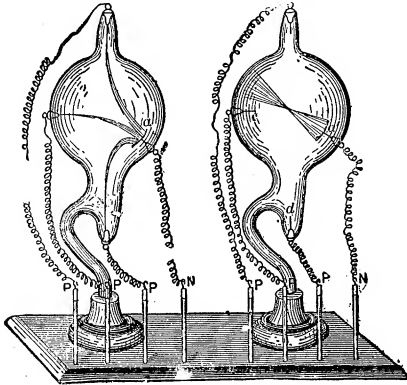

Fig. 394. Effects of Molecular Bombardment.

terminals are arranged as shown, the paths of the molecular streams are seen as luminous streams whose directions are those shown in the figures.

The figure on the left shows the path taken in a *low vacuum*. Streams pass from the negative electrode to each of the positive electrodes.

The figure on the right shows the discharge in a *high vacuum*. Here the streams pass off at right angles to the face of the negative electrode,

and proceed therefrom in straight lines, independently of the position of the positive electrode. Since, therefore, the negative electrode at *a*, is in the shape of a concave mirror, the luminous particles converge to a focus near the centre of the glass vessel, and then diverge to the opposite wall.

Refractory substances placed at such a *focus of molecular bombardment*, as shown in Fig. 395, are rendered incandescent.

In a similar manner, phosphorescent substances exposed to such molecular streams emit a beauti-

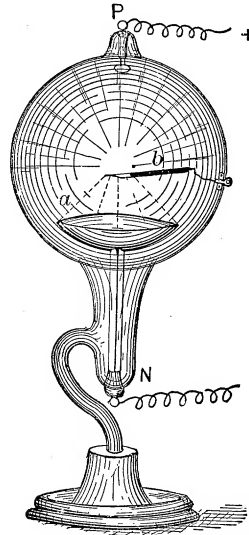

Fig. 395. Forces of Molecular Bombardment.

ful phosphorescent light. (See *Phosphorescence, Electric*.)

Matter, Thomson's Hypothesis of — —

A hypothesis as to the structure of matter suggested by Sir William Thomson, in order to show how the extremely tenuous ether might possess rigidity.

The fact that the ether, although a fluid substance, possesses the properties of a rigid solid, has given no little trouble to physicists. Thomson explains this rigidity of the ether as being due to a rapid motion in its fluid particles.

A perfectly flexible rubber tube filled with water or other fluid, possesses, when at rest, a very great degree of flexibility. When in motion, however, the tube becomes more and more rigid, as the flow increases in rapidity. Thom-

son imagines the ether to be set in motion in minute vortex rings, and shows that a readily movable fluid body, like ether, once set in such motion should possess the properties of a solid. In a perfect fluid, such as ether, these vortex rings once formed, would be practically imperishable or indestructible.

Thomson regards the atoms of matter as consisting of such vortex rings. Vortex rings can be formed in the air by cutting a circular aperture in the end of a pasteboard box, and tapping sharply against the end of the box. In order to render the rings visible, the box may be previously filled with smoke.

Vortex rings formed in smoky air differ from vortex rings in the ether, in the fact that air is not a perfect fluid, while ether is. Air vortex rings increase in size and decrease in energy. Vortex rings of the ether would not vary in size.

According to Thomson's vortex theory of matter, the atoms of matter are the same as the ether which surrounds them. They cannot be produced in ether by any known way; therefore, they cannot be manufactured, or, as it were, created. Nor, on the other hand, can they be destroyed; in other words, they are indestructible. They are elastic, capable of definite vibrations, possess all the properties of matter save, in the opinion of some, the very important property of gravitation. As Prof. Lodge points out, the fact that this property is not present should cause Sir William Thomson's theory of matter to be accepted with considerable hesitation.

Matthiessen's Metre-Gramme Standard.—(See *Metre-Gramme Standard, Matthiessen's*.)

Matthiessen's Mile Standard.—(See *Mile Standard, Matthiessen's*.)

Matting, Invisible Electric Floor — —A matting or other floor covering, provided with a series of electric contacts, which are closed by the passage of a person walking over them.

This matting is provided as an adjunct to a system of burglar alarms. The electric bell or annunciator, connected with the different contacts, is disconnected during the day-time, or while the rooms are occupied. (See *Alarm, Burglar*.)

Maximum Magnetization.—(See *Magnetization, Maximum*.)

McIntire's Parallel Sleeve Telegraphic Joint.—(See *Joint, Telegraphic, McIntire's Parallel Sleeve*.)

Measurements, Electric — —Determinations of the values of the electromotive force, resistance, current, capacity, energy, etc., in any electric circuit.

Electric measurements may be either qualitative or quantitative.

In qualitative electric measurements the relative values only are obtained; in quantitative measurements the actual values are obtained.

Mechanical Alarm, Electric — —(See *Alarm, Electro-Mechanical*.)

Mechanical Electric Bell.—(See *Bell, Electro-Mechanical*.)

Mechanical Equivalent of Heat.—(See *Heat, Mechanical Equivalent of*.)

Mechanical Mine.—(See *Mine, Mechanical*.)

Mechanical Throwback Indicator. — (See *Indicator, Mechanical Throwback*.)

Medical Induction Coil.—(See *Coil, Induction Medical*.)

Medical Magneto-Electric Apparatus.—(See *Apparatus, Magneto-Electric Medical*.)

Medium, Anisotropic — —A medium in which equal stresses do not produce equal strains when applied in different directions.

A medium, homogeneous in structure like crystalline bodies, but possessing different powers of specific inductive capacity in different directions.

An eolotropic medium. (See *Medium, Eolotropic*.)

The latter term is used to distinguish it from an isotropic medium. (See *Medium, Isotropic*.)

Medium, Eolotropic — —A medium in which equal stresses do not produce the same strains when applied in different directions. (See *Medium, Isotropic*.)

Medium, Electro-Magnetic — —Any medium in which electro-magnetic phenomena occur.

The medium through which electro-magnetic waves are propagated is now universally re-

garded as the luminiferous or universal ether. (See *Electricity, Hertz's Theory of Electro-Magnetic Radiations or Waves.*)

Medium, Isotropic — —A medium in which equal stresses applied in any direction produce equal strains.

A transparent medium which possesses the same optical or electric properties in all directions.

An optically homogeneous, transparent medium.

Such media are called isotropic to distinguish them from anisotropic or eolotropic, or those in which equal stresses produce unequal strains in different directions. (See *Medium, Anisotropic. Medium, Eolotropic.*)

Meg or Mega (as a prefix).—1,000,000 times; as, megohm, 1,000,000 ohms; megavolt, 1,000,000 volts.

Megaloscope, Electric — —An apparatus for the medical exploration of the cavities of the body.

The light necessary for exploration is obtained from a small incandescent lamp placed at the extremity of a tube, suitably shaped for introduction into the special organ for which it is devised. The organ so illumined throws its light on a prism, by means of which the light is caused to pass through a series of lenses by which it is viewed.

Megavolt.—1,000,000 volts.

Megohm.—1,000,000 ohms.

Meidinger Voltaic Cell.—(See *Cell, Voltaic, Meidinger.*)

Memory, Magnetic — —A term proposed by J. A. Fleming for coercive force.

Soft iron has but a feeble memory of its past magnetization.

Mercurial Connection.—(See *Connection, Mercurial.*)

Mercurial Contact. — (See *Connection, Mercurial.*)

Mercurial Temperature Alarm.—(See *Alarm, Mercurial Temperature.*)

Mercury Break.—(See *Break, Mercury.*)

Mercury Cup.—(See *Cup, Mercury.*)

Meridian, Astronomical — —A great circle passing through any point in the heavens, and the North and South poles of the heavens.

The astronomical meridian corresponds to the geographical meridian. The former is considered as passing around the dome of the heavens; the latter, around the surface of the earth. In order to locate any point in the heavens, a great circle of the heavens is caused to pass through that point and through the astronomical North and South poles.

Meridian, Geographical — —The geographical meridian of a place is a great circle passing through that place and the North and South geographical poles of the earth.

Meridian, Magnetic — —The magnetic meridian of any place is the meridian which passes through the poles of a magnetic needle at that place when in a position of rest under the free influence of the earth's magnetism.

The *plane of the magnetic meridian* at any place is a vertical plane passing through the poles of a magnetic needle in a position of rest under the free influence of the earth's magnetism at that place.

The magnetic meridian may be regarded as the vertical plane in which a freely suspended magnetic needle comes to rest in the earth's magnetic field.

Meridional.—Pertaining to the meridian.

Message Wire.—(See *Wire, Message.*)

Messenger Call.—(See *Call, Messenger.*)

Metallie Arc.—(See *Arc, Metallic.*)

Metallie Circuit.—(See *Circuit, Metallie.*)

Metallie Coating.—(See *Coating, Metallie.*)

Metallie Conducting Joint.—(See *Joint, Metallie Conducting.*)

Metallie Contact.—(See *Contact, Metallie.*)

Metallie Electric Conduction. — (See *Conduction, Electric, Metallie.*)

Metallization.—The rendering of a non-conducting surface electrically conducting by covering it with a metallic coating, so as to

enable it to readily receive a metallic coating by electro-plating. (See *Plating, Electro.*)

Metallochromes.—A name sometimes given to Nobili's rings. (See *Rings, Nobili's.*)

Metalloid.—A name formerly applied to a non-metallic body, or to a body having only some of the properties of a metal, as carbon, boron, oxygen, etc.

The term is now but little used.

Metallurgy, Electro — —That branch of applied science which relates to the electrical reduction or treatment of metals.

Metallurgical processes effected by the agency of electricity.

Electro-Metallurgy embraces :

(1.) The reduction of metals from their ores, either directly during fusion by the heat of the voltaic arc, or the heat of incandescence, or by the electrolysis of solutions of their ores, or ores in the fused state. (See *Electrolysis. Furnace, Electric.*)

(2.) Electroplating.

(3.) Electrotyping.

The application of electricity to the reduction of metals is carried on in the electric furnace for the reduction of the aluminium ores, for example.

Metals, Electric Deflagration of — —The volatilization of metals by electric incandescence.

Metals, Electric Refining of — —Purifying metals by means of electricity.

Different methods are employed for the electric refining of metals. They are generally electrolytic in character.

Metals, Electrical Protection of — —The protection of a metal from corrosion by placing it in connection with another metal, which, when exposed to the corroding liquid, vapor or gas, will form with the metal to be protected the positive element of a voltaic couple.

The negative element of a voltaic couple is protected by the presence of the positive element, which is alone corroded. This method has been adopted with considerable success to electrically protect metals from corrosion.

The following are examples of this protection :

(1.) Davy proposed to protect the copper

sheathing of ships from corrosion by attaching pieces of zinc to the copper sheathing. This succeeded too well, since the copper salts which were formerly produced, and acted as a poison to the marine plants and animals, being now absent, permitted these organisms to thrive to such an extent as to seriously foul the ship's bottom.

(2.) A ring of zinc attached to a lightning rod, near its points, has, it is claimed, the power of protecting the points from corrosion.

(3.) Iron bars of railings, if sunk or embedded in zinc, are preserved from corrosion near the junction of the two metals, but if sunk in lead are rapidly corroded, because iron is electro-positive to lead, but electro-negative to zinc.

(4.) Tinned iron rapidly corrodes or rusts when the iron is exposed to the atmosphere by a scratch or abrasion, because the iron is electro-positive to tin. Nickel-plated iron, for the same reason, rusts rapidly on the exposure of an abraded surface.

(5.) Zinced or galvanized iron, or iron covered with a deposit of zinc, is protected from corrosion because the zinc, being positive to iron, can alone be corroded, and the zinc is also protected in part by the coating of insoluble oxide that is formed.

Meteorites.—Aerolites. (See *Aerolites.*)

Meter, Ampère — —(See *Ampère-Meter. Ammeter.*)

Meter, Current — —A term now applied to an electric meter or galvanometer which measures the current in ampères, as distinguished from one which measures the energy in watts.

This term is sometimes loosely applied to a galvanometer.

The term galvanometer is preferable. (See *Galvanometer.*)

Meter, Current, Magneto-Static — —A current meter in which a small steel magnet, or system of magnets, is suspended at the centre of the uniform magnetic field produced by the combined influence of two coils and two systems of powerful permanent magnets.

Meter, Electric — —Any apparatus for measuring commercially the quantity of electricity that passes in a given time through any consumption circuit.

Electric meters are constructed in a great variety of forms; they may, however, be arranged under the following heads:

(1.) *Electro-Magnetic Meters*, or those in which the current passing is measured by the electro-magnetic effects it produces.

In such meters the entire current may pass through the meter.

(2.) *Electro-Chemical Meters*, or those in which the current passing is measured by the electrolytic decomposition it effects.

In these meters, a shunted portion only of the current is usually passed through a solution of a metallic salt, and the current strength calculated from the amount of electrolytic decomposition thus effected.

(3.) *Electro-Thermal Meters*, or those in which the current passing is measured by a movement effected by the increase in temperature of a resistance through which the current is passed, or by the amount of a liquid evaporated by the heat generated by the current.

(4.) *Electric-Time Meters*, or those in which no attempt is made to measure the current that passes, but in which a record is kept of the number of hours that an electric lamp, motor or other electro-receptive device is supplied with current.

Edison's electric meter is of the second class. It consists of two *vollameters*, or electrolytic cells, containing zinc sulphate, in which two plates of chemically pure zinc are dipped. The current that passes is determined by the amount of the variation in weight of the zinc plates. To determine this, the plates are weighed at stated intervals: one plate every month, the other plate, which is intended to act as a check on the first, only once in three months. Some difficulty has been experienced in the employment of meters of this class, from the variations in the value of the shunt resistance, due to variations in the condition and temperature of the electrolytic cell. The use of a compensating resistance, however, has, it is claimed, removed this objection. (See *Vollameter*.)

Meter, Electric-Time — — An electric meter in which the current passing is estimated by recording the number of hours that an electric lamp or other electro-receptive device is supplied with a known current. (See *Meter, Electric*.)

Meter, Electro-Chemical — — An electric meter in which the current passing is measured by the electrolytic decomposition it effects. (See *Meter, Electric*.)

Meter, Electro-Magnetic — — An electric meter in which the current passing is measured by the electro-magnetic effects it produces. (See *Meter, Electric*.)

Meter, Electro-Thermal — — An electric meter in which the current passing is measured by means of the heat generated by the passage of the current through a resistance. (See *Meter, Electric*.)

Meter, Energy — — A term, sometimes applied to a watt meter. (See *Meter, Watt*.)

Meter, Milli-Ampère — — An ampère meter graduated to read milli-ampères.

Meter, Watt — — An instrument generally consisting of a galvanometer constructed so as to measure directly the product of the current, and the difference of potential.

Since the watt is equal to the product of the

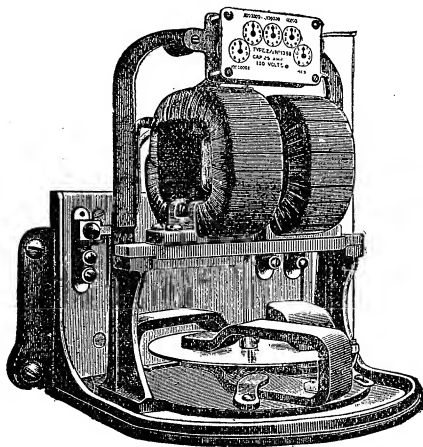

Fig. 396. Watt Meter.

current by the electromotive force, if the current and electromotive force are simultaneously measured, their product gives directly the watts. The scale reading of a watt meter may be graduated so as to give the watts directly.

A watt meter consists essentially of a thick wire coil, placed in series in the circuit whose electric power is to be measured, and a thin wire coil

placed in a shunt around the circuit to be measured. These two coils, instead of acting on a needle, act on each other, and the amount of this deflection will, therefore, be proportional to the watts present.

A form of watt meter is shown in Fig. 396.

Method, Deflection — —A method employed in electrical measurements, as distinguished from the zero method, in which a deflection, produced on any instrument by a given current, or by a given charge, is utilized for determining the value of that current or charge.

The conditions remaining the same, the same current or charge will produce the same deflection at any time. Different deflections produced by currents or charges, the values of which are unknown, are determined by certain ratios existing between the deflections and the currents or charges. These ratios are determined experimentally by the *calibration* of the instrument. (See *Calibrate.*)

Deflection methods are opposed to *zero* or *null methods*, in which latter a balance of opposite electromotive forces, or a proportionally equal fall of electric potential, is ascertained by the failure of a delicately poised needle to be moved by a current or a charge.

Method, Null or Zero — —Any method employed in electrical measurements, in which the values of the electromotive force in volts, the resistance in ohms, or the current in amperes, or other similar units, are determined by balancing them against equal values of the same units, and ascertaining such equality, not by the deflections of the needle of a galvanometer, or of an electrometer, but by the absence of such deflections.

The advantage of zero methods is found in the fact that the galvanometer or electrometer may then be made as sensitive as possible, which is not otherwise the case, since great deflections are generally to be avoided, especially in tangent galvanometers. (See *Galvanometer. Electrometer.*)

Method of Magnetization by Touch.— (See *Magnetization by Touch.*)

Methven's Screen.—(See *Screen, Methven's.*)

Metre Bridge.—(See *Bridge, Metre.*)

Metre Candle.—(See *Candle, Metre.*)

Metre-Gramme Standard, Matthiessen's

— —A unit of resistance.

The resistance of a wire one metre in length, and of such a diameter as would cause the wire to weigh one gramme.

One metre-gramme of pure hard drawn copper has a resistance of .1469 B. A. units at zero degrees C. as determined by Matthiessen (*Phil. Mag.*, May, 1865).

Metre-Millimetre — — A resistance unit of length of a wire or other conductor of the length of one metre and of the area of cross-section of one square millimetre.

According to the report of the Committee of the American Institute of Electrical Engineers of 1890, on a Standard Wiring Table, a metre-millimetre of pure soft copper wire has a resistance of .02057 B. A. units at zero degrees C. From the corresponding term, milfoot, millimetre-metre would appear to be the preferable term.

Metric Horse-Power.—(See *Horse-Power, Metric.*)

Metric System of Weights and Measures.—(See *Weights and Measures, Metric System of.*)

Mho.—A term proposed by Sir Wm. Thomson for the practical unit of conductivity.

Such a unit of conductivity as is equal to the reciprocal of 1 ohm.

The conducting power is equal to $\frac{1}{R}$ or the reciprocal of the resistance.

The word *mho*, as is evident, is obtained by inverting the order of sequence of the letters in the word *ohm*.

Mica.—A mineral substance employed as an insulator.

Mica is a silicious mineral. It occurs of varying degrees of transparency, and splits or cleaves readily into transparent laminae. It is a good non-conductor, is fairly fire-proof, and is not hydroscopic.

Mica is used extensively in insulating the metallic segment of commutators of motors and dynamo-electric machines and in various other electric work.

Mica, Moulded — An insulating substance consisting of finely divided mica made into a paste, with some fused insulating substance, and moulded into any desired shape.

Finely divided mica mixed with gum-shellac rendered plastic by means of heat, forms a good insulating substance.

Micro (as a prefix).—The one-millionth; as, a microfarad, the millionth of a farad; a microvolt, the one-millionth of a volt.

Micro-Farad.—(See *Farad, Micro*.)

Micro-Graphophone.—A modified form of phonograph in which several independent non-metallic diaphragms are used instead of the single diaphragm of the phonograph. (See *Graphophone, Micro*.)

Micrometer, Arc — An apparatus for the accurate measurement of the length of a voltaic arc by means of a micrometer.

The distance between two carbon electrodes—one movable and the other fixed—placed inside a glass vessel, is accurately determined by means of a micrometer placed on the movable electrode. The operation is similar to that of the *vernier wire gauge*.

Micrometer, Spark — A term sometimes applied to Hertz's electric resonator. (See *Resonator, Electric*.)

Micron.—A measure of length.

The one-millionth part of a metre.

The micron is equal to .00004 of an inch, very nearly.

Microphone.—An apparatus invented by Prof. Hughes for rendering faint or distant sounds distinctly audible.

The microphone depends for its operation on variations produced in the resistance of the circuit of a battery, or other electric source, by means of a loose contact. These variations in the resistance are caused to produce corresponding movements in the diaphragm of a receiving telephone.

The loose contact may take a variety of forms. Originally it was made in the form shown in Fig. 397, in which a small piece of carbon E, pointed at both ends, is inserted in holes near the ends of cross-pieces of carbon B and C. The thin upright board A, on which these are supported, acts as a

sounding board or diaphragm, and its movements by sound waves are at once audible to a person listening at the receiving telephone. The walking of a fly over the sounding board is heard as a loud sound.

The forms of transmitting telephones invented by Reis, Edison, Blake, Berliner and others, are in reality varieties of microphones.

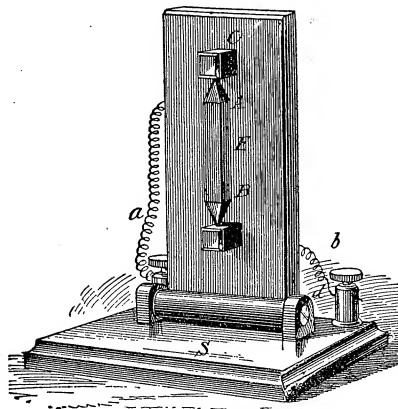

Fig. 397. Microphone.

Microphone Relay.—(See *Relay, Microphone*.)

Micro-Seismograph.—(See *Seismograph, Micro*.)

Microtasimeter.—An apparatus invented by Edison to measure minute differences of temperature, or of moisture, by the resulting differences of pressure.

A change of temperature, or moisture, is caused to produce variations in the resistance of a button of compressed lampblack, placed in the circuit of a delicate galvanometer. The apparatus, though of surprising delicacy, is scarcely capable of practical application, from the fact that the resistance of the carbon does not resume its normal value on the removal of the pressure.

Micro-Volt.—(See *Volt, Micro*.)

Mil.—A unit of length equal to the $\frac{1}{1000}$ of an inch, or .001 inch, used in measuring the diameter of wires.

Mil, Circular — A unit of area employed in measuring the areas of cross-sections of wires, equal to .78540 square mil. The area of a circle one mil in diameter.

One circular mil equals .000000785 square inch.

The area of cross-section of a circular wire in circular mils is equal to the square of its diameter expressed in mils. (See *Units, Circular.*)

Mil-Foot.—A resistance unit of length of one foot of wire or other conductor of one mil diameter.

The resistance of a mil-foot of soft copper wire or wire 1 foot long and .001 of an inch in diameter is equal to 9.720 B. A. units at 0 degrees C.

Mil, Square — —A unit of area employed in measuring the areas of cross-sections of wires, equal to .000001 square inch.

One square mil equals 1.2732 circular mil.

Mile, Nautical — —A knot, or a distance of 6,087 feet, or very nearly 1.15 statute miles.

The $\frac{1}{314159}$ of the earth's equatorial circumference, or the $\frac{1}{360}$ of a degree of longitude at the equator, or about 2,029 yards.

A nautical or geographical mile being the $\frac{1}{314159}$ of 24,899 miles, has a value somewhat greater than that of the statute mile.

Mile Standard, Matthiessen's — —A standard of resistance equal to the resistance of one mile of pure copper wire $\frac{1}{16}$ inch in diameter at 15.5 degrees C.

Matthiessen's mile standard has a resistance of 13.59 B. A. units at 15.5 degrees C.

Mile, Statute — —The ordinary unit of distance on land, equal to 5,280 feet.

Milli (as a prefix).—The one-thousandth part.

Milli-Ampère.—The thousandth of an ampère.

Milli-Calorie.—The smaller calorie. (See *Calorie, Small.*)

Milli-Oerstedt.—The one-thousandth of an Oerstedt.

Mimosa Sensitive.—A sensitive plant whose leaves fold or shut up when touched.

The fibres of all the sensitive plants, such, for example, as the above, the Venus' Fly-trap, etc., like all muscular fibre, and indeed all protoplasm, suffer contraction when traversed by electric currents.

Mine, Electro-Contact — —A submarine mine that is fired automatically on the completion of the current of a battery

placed on the shore through the closing of floating contact points by passing vessels. (See *Mine, Submarine.*)

Mine Exploder, Electro-Magnetic — —A form of electro-magnetic exploder. (See *Exploder, Electro-Magnetic.*)

Mine, Mechanical — —A submarine mine that is fired when struck by a passing ship by the action of some contrivance contained within the torpedo itself, and having no connection whatever with the shore.

Mine, Observation — —A variety of submarine mine that is fired when the enemy's vessels are observed to be within the destructive area of the mine. (See *Mine, Submarine.*)

Various means are adopted for obtaining the current required for firing such mines. A sufficiently powerful battery is generally used. An electro-magnetic mine exploder may, under certain circumstances, be employed. (See *Mine Exploder, Electro-Magnetic.*)

Mine, Submarine — —A mass of gun-cotton or other explosive contained in a water-tight vessel and placed under water so as to be exploded on the passage over it of an enemy's vessel.

A submarine mine is a stationary torpedo arranged for the defense of a harbor. A harbor is protected by a number of mines which are so arranged as to be readily exploded by the passage of an enemy's ship, but safely crossed by other vessels.

Submarine mines consist essentially of gun-cotton or other explosives contained in water-tight vessels anchored in very carefully located positions, and connected with the shore by means of cables.

An operating-room at the shore end of the cable is furnished with batteries, measuring instruments, contact keys, etc., etc., by means of which the mines can be exploded by the transmission of an electric current through the cables; or, the mines are furnished with automatic circuit closers in which two central points are closed by the passage of the vessel. In ordinary times this current is too weak to ignite the fuse, and merely closes a relay in the operating-room, which in turn directs a current through a bell or indicator, but, of course, too weak to fire the fuse.

In times of war, however, the relay sends a current through the cable sufficiently strong to heat a platinum iridium fuse, ignite a fulminate of mercury cap, and thus, by the detonation of the primer of dry gun-cotton, explode the full charge of damp gun-cotton in the torpedo or mine.

Mine, Subterranean — —A mass of gun powder, gun-cotton or other explosive, placed under ground in vessels suitable for protection against moisture, and fitted with electrically connected electric fuses, which are either exploded automatically by the movement of an enemy over them, or by an operator placed at a safe distance within an entrenchment.

Minute, Ampère — —One ampère flowing for one minute. (See *Hour, Ampère.*)

Minute, Watt — —A unit of electrical work.

The expenditure of an electrical power of one watt for one minute.

The watt-minute is equal to 60 joules. This unit of electrical work is seldom used.

Miophone.—An apparatus invented by Boudet based on the use of the microphone, and designed for the medical examination of the muscles.

Mirror Galvanometer.—(See *Galvanometer, Mirror.*)

Moist Electrode.—(See *Electrode, Moist.*)

Moisture, Effect of, on Electrical Phenomena — —The influence of moisture on the surfaces of insulators in causing the loss or dissipation of an electric charge.

This loss is more rapid with *negatively charged bodies* than with those positively charged.

Molar Attraction. — (See *Attraction, Molar.*)

Molecular.—Pertaining to the molecule. (See *Molecule.*)

Molecular Attraction.—(See *Attraction, Molecular.*)

Molecular Bombardment.—(See *Bombardment, Molecular.*)

Molecular Chain.—(See *Chain, Molecular.*)

Molecular Currents.—(See *Currents, Molecular or Atomic.*)

Molecular Currents, Induced — —(See *Currents, Induced Molecular or Atomic.*)

Molecular Range.—(See *Range, Molecular.*)

Molecular Repulsion.—(See *Repulsion Molecular.*)

Molecular Rigidity. — (See *Rigidity, Molecular.*)

Molecular Theory of Muscle and Nerve Currents.—(See *Theory, Molecular, of Muscle and Nerve Currents.*)

Molecule.—A group of atoms whose chemical bonds or affinities are mutually satisfied.

The smallest quantity of a compound substance that can exist as such.

Water is a compound substance formed of two atoms of hydrogen combined with one atom of oxygen. The molecule of water, therefore, or the smallest quantity of water that can exist, must contain two atoms of hydrogen and one of oxygen.

The molecule of hydrogen consists of two atoms of hydrogen. Since hydrogen is a monad, or an element whose atomicity is one, it can combine with one atom of hydrogen and form a molecule, since then its bonds will be fully satisfied. (See *Atomicity.*)

Molecule, Closed-Magnetic Circuit of — —(See *Circuit, Closed-Magnetic, of Molecule.*)

Molecule, Gramme — —The weight of any substance taken in grammes numerically equal to the molecular weight.

Moment, Magnetic — —The sum of the two forces of the directive couple multiplied by half the perpendicular distance between the directions of these forces; or, in other words, the moment of a magnet is equal to its length multiplied by the intensity of the magnetism of one of its poles. (See *Couple, Magnetic.*)

Moment of Couples.—(See *Couple, Moment of.*)

Momentary Current.—(See *Current, Momentary.*)

Momentum, Electro-Magnetic, of Secondary Circuit — —A quantity equal to

the co-efficient of mutual induction, multiplied by the current strength in the primary, when the primary current is fully established.

When the primary current is fully established, the number of lines of force which pass through the secondary circuit is equal to the co-efficient of mutual induction, multiplied by the strength of the primary current.

Monophotal Arc-Light Regulator.—(See *Regulator, Monophotal Arc-Light.*)

Morley Effect.—(See *Effect, Morley.*)

Morse Alphabet.—(See *Alphabet, Telegraphic: Morse's.*)

Morse Inker.—(See *Inker, Morse.*)

Morse Recorder.—(See *Recorder, Morse.*)

Morse Register.—(See *Register, Morse.*)

Morse System of Telegraphy.—(See *Telegraphy, Morse System of.*)

Morse's Telegraphic Alphabet.—(See *Alphabet, Telegraphic: Morse's.*)

Morse's Telegraphic Sounder.—(See *Sounder, Morse's Telegraphic.*)

Motion, Energy of — — A term sometimes applied to actual or kinetic energy in contradistinction to potential energy. (See *Energy, Actual.*)

Motion, Simple-Harmonic — — Motion which repeats itself at regular intervals, taking place backwards or forwards, and which may be studied by comparison with uniform motion round a circle of reference.—(*Daniell.*)

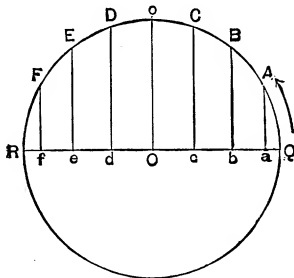

Fig. 398. Simple-Harmonic Motion.

Motion which is a simple periodic function of the time.

Suppose a pendulum be set swinging in a certain path. If the path of such a pendulum, or, as it is generally called, a conical pendulum, be

looked at from above or from below, it will appear to be circular; if observed from one side it will appear elliptical, and this elliptical path will appear longer and narrower as the eye of the observer approaches the level of the plane in which the bob moves, when the bob will appear to travel backwards and forwards in a straight line. The bob will appear to be moving faster, when it is moving right across the field of view.

Let the circle Q C R (Fig. 398) be the path in which the bob moves, and let Q A, A B, B C, C o, etc., be equal distances in such path. Let the lines A a, B b, C c, o O, etc., be drawn perpendicular to the line Q R. Then when looked at, with the eye on the level of the plane in which the bob travels, the line Q R, will be the path in which the bob appears to move backwards and forwards, and the lines, Q a, a b, b c, c O, etc., will represent the spaces apparently traversed in equal intervals of time.

The circle Q o R, is called the circle of reference.

Motion, Simple-Harmonic, Amplitude of — — The length of the swing from the median position to its extreme position, in either direction.

The line O Q, or O R, in the circle of reference Q O R (Fig. 398).

Motion, Simple-Harmonic, Negative Direction of — — The motion which a body, with a simple-harmonic motion, has when it appears to move from left to right.

Motion, Simple-Harmonic, Period of — — The interval of time which elapses between two successive passages of a moving particle, over the same point, in the same direction.

The period of simple-harmonic motion represents the time of one complete motion around a circle called the circle of reference. (See *Motion, Simple-Harmonic.*)

Motion, Simple-Harmonic, Phase of — — The position of a point executing a simple harmonic motion, expressed in terms of the interval of time which has elapsed since such point last passed through the middle of its path in the positive direction.—(*Anthony & Brackett.*)

The exact position of a particle executing a simple-harmonic motion for any instant of time can be readily expressed in terms of the phase.

Motion, Simple-Harmonic, Positive Direction of — The motion which a body moving in simple-harmonic motion has, when it appears to move from right to left.

Motion, Simple-Periodic — A term sometimes employed in the sense of simple-harmonic motion. (See *Motion, Simple-Harmonic.*)

Motion, Simple-Sine — A term sometimes employed in the sense of simple-harmonic motion. (See *Motion, Simple-Harmonic.*)

Motograph, Electro — An apparatus invented by Edison whereby the friction of a platinum point against a rotating cylinder of moist chalk, is reduced by the passage of an electric current.

This result is due to electrolytic action at the points of contact, varying the friction.

The electro-motograph, though less certain in its action than an electro-magnet, may replace it in certain electric apparatus.

The detailed construction of the electro-motograph will be understood from an inspection of Fig. 399.

The lever A, pivoted with a universal joint at C, has a metallic point at its free extremity F, resting on a strip of moistened paper N, and held against it with some pressure by the action of the spring S. The paper N, rests on the metallic drum G, over which it is moved on the rotation of the drum by clockwork. A spring R, acts to move the lever A, in a direction opposite to that in which it tends to move by the rotation of the drum G.

The main battery L, is connected at its negative pole to the point F, and at its positive pole, through the key K, to the metallic drum G. The local battery L B, is connected through the sounder X, to the contacts D and X.

When the key K, is open, the friction of F, on the paper N, is sufficient to move the lever A, to the right so as to close the circuit of the local battery, but when the key K, is depressed, the current of L, passing through the paper, decomposes the chemicals with which it is moistened, lessens the friction of the point F, and permits the spring B, to draw the lever A, to the left, thus opening the circuit of the local battery L B.

The movements of the key are therefore reproduced by the armature of the electro-magnet X.

An excellent loud speaking telephone has been devised by Edison on the principle of the electro-motograph.

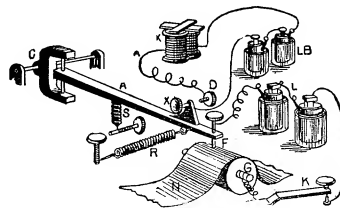

Fig. 399. Electro-Motograph.

Motor, Compound-Wound — An electric motor whose field magnets are excited by a series and a shunt wire. (See *Machine, Dynamo-Electric, Compound-Wound.*)

Motor, Differentially Wound — A compound-wound motor, in which the current in the shunt coils opposes in its magnetizing effects the current in a series coil, so that the efficient magnetizing effect produced is the difference in the magnetizing effect of the two coils.

Motor, Electric — A device for transforming electric power into mechanical power.

All practical electric motors depend for their operation on the tendency to motion in a magnetic field of a conductor carrying a current or on magnetic attraction or repulsion. The entire magnetism may be produced by the current, or part may be obtained from permanent magnets, and the rest from electro-magnets.

A dynamo-electric machine will act as a motor if a current is sent through it. Such a motor is sometimes called an *electro-motor*. The term electric motor would, however, appear to be the preferable one.

In all cases the rotation is in such a direction as to induce in the armature an electromotive force opposed to that of the driving current; this is therefore called the counter electromotive force.

A *magneto-dynamo*, or a dynamo the field of which is obtained from permanent magnets, or a *separately excited dynamo*, will operate as a motor when a current is sent through its armature, and will turn it in the *opposite direction* to that required to drive it in order to produce a current in the same direction.

A *series dynamo* will operate as a motor when

a current is sent through it. If the current is sent through it in the opposite direction to that which it produces when in operation as a *generator*, the polarity of the field is reversed and the dynamo will turn as a motor in the *opposite direction* to that required to produce the current. If the current is reversed, the polarity of both the field and the armature is again reversed, and the dynamo still rotates as a motor in the *opposite direction* to that in which it is rotated as a generator.

A series dynamo, therefore, always rotates as a motor in a direction opposite to that of its rotation as a generator.

When, however, the polarity of the field only is reversed by changing the connection between the armature and the field, the rotation is in the same direction.

A shunt dynamo operated as a motor will also turn in but one direction, but this direction is the same as that in which it turns when operating as a generator; for if the direction of the current in the armature is the same as in a generator, that in the shunt is reversed.

A compound-wound dynamo will move in a direction opposite to that of its motion as a generator if the series part is more powerful than the shunt, and in the same direction if the shunt part is more powerful than the series. To use a compound-wound dynamo as a differential motor the connections need not be changed. For a cumulative motor it is necessary to reverse the connections of the series coils.

Alternating-Current Dynamo.—The current from an alternating-current dynamo, if sent through another similar alternating-current dynamo running at the same speed, will drive it as a motor. Such a machine possesses the disadvantage of requiring to be maintained at a speed depending on that of the driving dynamo, and also that it requires to be brought to nearly this speed before the driving current is supplied to it. As a result of this last requirement, variations in the load are apt to stop the motor. Considerable improvements, however, are being introduced into alternate-current motors, by which these difficulties are almost entirely removed.

An alternating current sent through any self-exciting dynamo-electric machine, such as a shunt or series machine, will drive it continuously as a motor. The sudden reversals in the magnetization of its cores will, however, unless the cores are thoroughly laminated, set up power-

ful eddy currents that will injuriously heat the machine, and there is also excessive sparking at the brushes.

The *reversibility of any dynamo-electric machine*, or its ability to operate as a motor if supplied with a current, leads to a fact of great importance in the efficiency of electric motors, viz.: that during rotation there is induced in the armature during its passage through the field of the machine, an electromotive force opposed to that produced in the armature by the driving current, or a *counter electromotive force*. (See *Resistance, Spurious Force, Counter Electromotive*.) This counter electromotive force acts as a *spurious resistance*, and opposes the passage of the driving current, so that, as the speed of the electric motor increases, the strength of the driving current becomes less, until, when a certain maximum speed is reached, very little current passes. In actual practice, this maximum speed is not attained, or is only momentarily attained, and a small, nearly constant, current is expended in overcoming friction at the bearings, air friction, etc.

When, however, the load is placed on the motor, that is, when it is caused to do work, the speed is reduced and the counter electromotive force is decreased, thus permitting a greater current to pass. The fact that the load thus automatically regulates the current required to drive the motor, renders electric motors very economical in operation.

The relations between the power required to drive the generating dynamo, and that produced by the electric motor, are such that *the maximum work per second is done by the motor when it runs at such a rate that the counter electromotive force it produces is half that of the current supplied to it*. The maximum work or activity of an electric motor is therefore done when its theoretical efficiency is only 50 per cent. This, however, must be carefully distinguished from the maximum efficiency of an electric motor. A maximum efficiency of 100 per cent. can be attained theoretically; and, in actual practice, considerably over 90 per cent. is obtained. In such cases, however, the motor is doing work at less than its *maximum power*.

This is Jacobi's law of maximum effect, but does not apply to *actual* motors on account of the limitations of current carrying capacity. For example, a motor of 9 horse-power and 90 per cent. efficiency loses 1 horse-power in heat within

itself. Hence, if run according to Jacobi's law, it would only produce the same amount, *i. e.*, 1 horse-power in useful work instead of 9. More than this would overheat it.

An efficiency of 100 per cent. is reached when the counter electromotive force of the motor is equal to that of the source supplying the driving current. Supposing now the driving machine to be of the same type as the motor, and the two machines *are running at the same* speed. If now a load is put on the motor so as to reduce its speed, and thus permit it to produce a counter electromotive force of but 90 per cent., its efficiency will be but 90 per cent. In such a case, therefore, the efficiency is represented by the relative speeds of the generator and the motor.

Motor, Electric, Alternating-Current — —An electric motor driven or operated by means of alternating currents. (See *Motor, Electric.*)

Dr. Louis Duncan divides alternating motors into two classes, *viz.*:

(1.) Those in which there is but one transformation in the machine, *viz.*, that of the electric energy of the armature current into the mechanical energy of the armature's rotation.

(2.) Those in which there are two transformations, *viz.*:

(a.) The transformation of electrical energy from the main current to electrical energy in the armature current.

(b.) The transformation of the electric energy of the armature current into mechanical energy.

Alternating motors of the first type are found in the ordinary alternating-current dynamo reversed. Those of the second type in Tesla's or Thomson's motors.

Motor, Electric, Direct-Current — — An electric motor driven or operated by means of direct or continuous electric currents, as distinguished from a motor driven or operated by alternating currents. (See *Motor, Electric.*)

Motor, Electric, High-Speed — —The ordinary electric motor.

The term high-speed electric motor is used in contradistinction to low-speed electric motor. (See *Motor, Electric, Low-Speed.*)

Motor, Electric, Low-Speed — —A

slow-speed motor. (See *Motor, Electric, Slow-Speed.*)

Motor, Electric, Overload of — —A load greater than that which an electric motor can carry while at its greatest efficiency of operation, or a load which causes injurious heating of a motor.

Motor, Electric, Reversing Gear of — —Apparatus for so reversing the direction of the current through an electric motor as to reverse the direction of its rotation. (See *Rail-road, Electric.*)

Motor, Electric, Slow-Speed — —An electric motor so constructed as to run with fair efficiency at slow speed.

The electric motor develops a counter electromotive force when in motion, which, of course, increases with the increase of motion. The electric motor has, as generally constructed, its greatest efficiency at high speed. When used on street railroads, the high speed requires to be decreased by various forms of reduction gear. The loss of power which all such gear involve, together with the noise attending their use, render any decrease in speed that can be obtained on the part of the motor, without serious loss of efficiency, desirable.

Motor-Electromotive Force.—(See *Force, Motor Electromotive.*)

Motor, Pyromagnetic — — A motor driven by the attraction of magnet poles on a movable core of iron or nickel unequally heated.

The intensity of magnetization of iron decreases with an increase of temperature, iron losing most of its magnetization at a red heat. A disc of iron placed between the poles of a magnet, so as to be capable of rotation, will rotate, if heated at a part nearer one pole than the other, since it becomes less powerfully magnetized at the heated part.

In the form of pyromagnetic motor devised by Edison, and shown in Fig. 400, in elevation, and in Fig. 401, in vertical section, the disc of iron is replaced by a series of small iron tubes, or divided annular spaces, heated by the products of combustion from a fire placed beneath them. In order to render this heating local, a flat screen is placed dissymmetrically across the top to prevent

the passage of air through the portion of the iron tubes so screened. The air is supplied to the furnace by passing down from above through the

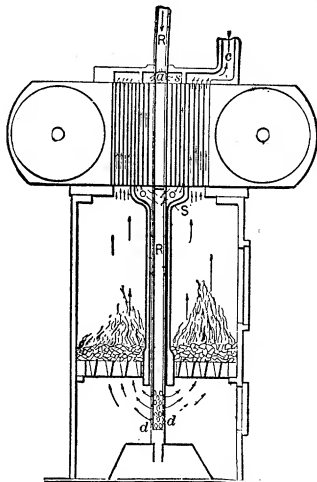

Fig. 400. Pyromagnetic Motor.

tubes so screened. This is shown in the drawings, the direction of the heating and the cooling air currents being indicated by the arrows. The

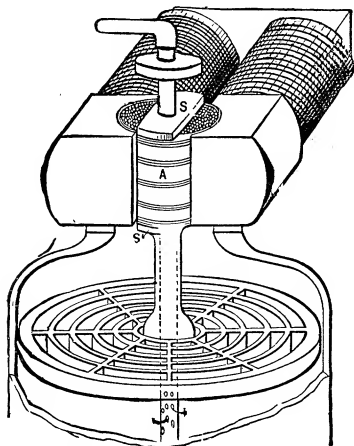

Fig. 401. Pyromagnetic Motor.

supply of air from above thus insures the more rapid cooling of the screened portion of the tubes.

Motor, Rotating-Current — — An electric motor designed for use with a rotating electric current.

Unlike alternating current motors, rotary-current motors will, like continuous-current motors, readily start with a load. (See *Current, Rotating*.)

Motor, Series-Wound — — An electric motor in which the field and armature are connected in series with the external circuit as in a series dynamo. (See *Machine, Dynamo-Electric, Series-Wound*.)

Motor, Shunt-Wound — — An electric motor in which the field magnet coils are placed in a shunt to the armature circuit. (See *Machine, Dynamo-Electric, Shunt-Wound*.)

Motor Standards. — (See *Standards, Motor*.)

Moulded Mica.—(See *Mica, Moulded*.)

Moulding, Electric Wood — — Moulding of dried, non-conducting wood, provided with longitudinal grooves for the reception and support of electric wires or conductors.

Wood mouldings are employed for the protection and concealment of electric conductors.

Moulding Wiring. — (See *Wiring, Moulding*.)

Mouse-Mill Dynamo. — (See *Dynamo, Mouse-Mill*.)

Mouse-Mill Machine.—(See *Machine, Mouse-Mill*.)

Mouth Pieces.—(See *Pieces, Mouth*.)

Movable Secondary. — (See *Secondary, Movable*.)

Mover, Prime — — In a system of distribution of power the motor by which secondary motors or movers are driven.

In a steam plant, the steam engine is the prime mover; the shafts or machines driven by the main shaft are sometimes called the secondary movers. The main shaft is called the driving shaft. Its motion is carried by means of belts to other shafts, called driven shafts. The pulleys on the driving or driven shafts are called respectively the driving and driven pulleys.

Movers, Secondary — — The shafts or machines driven by the main shafts in order to distinguish them from the steam engine or other mover which drives it. (See *Mover, Prime*.)

Multi-Cellular Electrostatic Voltmeter.—(See *Voltmeter, Multi-Cellular Electrostatic.*)

Multiphase Current.—(See *Current, Multiphase.*)

Multiphase Dynamo.—(See *Dynamo, Multiphase.*)

Multiphase System.—(See *System, Multiphase.*)

Multiple-Arc Circuit.—(See *Circuit, Multiple-Arc.*)

Multiple-Arc-Connected Electro-Receptive Devices.—(See *Devices, Electro-Receptive, Multiple-Arc-Connected.*)

Multiple-Arc-Connected Sources.—(See *Sources, Multiple-Arc-Connected.*)

Multiple-Arc-Connected Translating Devices.—(See *Devices, Translating, Multiple-Arc-Connected.*)

Multiple-Brush Rocker.—(See *Rocker, Multiple-Brush.*)

Multiple-Brush Yoke.—(See *Yoke, Multiple-Pair Brush.*)

Multiple Cable Core.—(See *Cable, Multiple-Core.*)

Multiple Circuit.—(See *Circuit, Multiple.*)

Multiple Conduit.—(See *Conduit, Multiple.*)

Multiple-Connected Battery.—(See *Battery, Multiple-Connected.*)

Multiple-Connected Electro-Receptive Devices.—(See *Devices, Electro-Receptive, Multiple-Connected.*)

Multiple-Connected Electro-Receptive Devices, Automatic Cut-Out for — — (See *Cut-Out, Automatic, for Multiple-Connected Electro-Receptive Devices.*)

Multiple-Connected Translating Devices.—(See *Devices, Translating, Multiple-Connected.*)

Multiple Connection.—(See *Connection, Multiple.*)

Multiple Distribution of Electricity by Constant Potential Circuits.—(See *Electricity, Multiple Distribution of, by Constant Potential Circuits.*)

Multiple Electric-Gaslighting.—(See *Gaslighting, Multiple Electric.*)

Multiple-Series.—A multiple connection of series groups. (See *Connection, Series Multiple.*)

Usage in regard to this term is divided. By some the term multiple-series is applied to a series connection of parallel groups. This is done on account of the order of the words, multiple-series indicating, it is claimed, a series connection of multiple groups.

Multiple-Series Circuit.—(See *Circuit, Multiple-Series.*)

Multiple-Series-Connected Electro-Receptive Devices.—(See *Devices, Electro-Receptive, Multiple-Series-Connected.*)

Multiple-Series-Connected Sources.—(See *Sources, Multiple-Series-Connected.*)

Multiple-Series-Connected Translating Devices.—(See *Devices, Translating, Multiple-Series-Connected.*)

Multiple-Series Connection.—(See *Connection, Multiple-Series.*)

Multiple-Switch Board.—(See *Board, Multiple-Switch.*)

Multiple Transformer.—(See *Transformer, Multiple.*)

Multiple Transmission.—(See *Transmission, Multiple.*)

Multiple Working of Dynamo-Electric Machines.—(See *Working, Multiple, of Dynamo-Electric Machines.*)

Multiplex Telegraphy.—(See *Telegraphy, Multiplex.*)

Multiplicator.—A word sometimes used for multiplier.

Multiplier, Galvanic — — A term formerly applied to a galvanometer. (See *Galvanometer.*)

Multiplier, Schweigger's — — The name first given to a coil consisting of a

number of turns of insulated wire, provided for the purpose of increasing the strength of the magnetic field produced by an electric current, and consequently the amount of its deflecting power on a magnetic needle.

Schweigger's multiplier was in fact an early form of galvanometer. (See *Galvanometer*.)

Multiplying Power of Shunt.—(See *Shunt, Multiplying Power of*.)

Multipolar Armature.—(See *Armature, Multipolar*.)

Multipolar Dynamo-Electric Machine.—(See *Machine, Dynamo-Electric, Multipolar*.)

Multipolar-Electric Bath.—(See *Bath, Multipolar Electric*.)

Muscle Current.—(See *Current, Muscle*.)

Muscles, Electrical Excitation of — — (See *Excitation, Electro-Muscular*.)

Muscular, Electro — — Pertaining to the influence of electricity on the muscles.

Muscular or Nerve Fibre, Excitability of — — (See *Excitability, Electric, of Nerve or Muscular Fibre*.)

Muscular Pile, Matteucci's — — (See *Pile, Muscular, Matteucci's*.)

Musket, Electric — — A gun in which the charge is ignited by a platinum wire rendered incandescent by the action of a battery placed in the stock of the gun.

Mutual Inductance.—(See *Inductance*.)

Mutual Induction. — (See *Induction, Mutual*.)

Mutual Induction, Co-efficient of — — (See *Induction, Mutual, Co-efficient of*.)

Myria (as a prefix).—A million times.

N

N.—A contraction employed in mathematical writings for the whole number of lines of magnetic force in any magnetic circuit.

N.—A contraction for North Pole.

This N, may be distinguished from the N, used for expressing the whole number of lines of magnetic force, by making the former light and the latter heavy.

N. H. P.—A contraction for Nominal Horse-Power.

Nominal horse-power is a somewhat indefinite term for a quantity dependent on the length of stroke and the dimensions of the cylinder. This quantity is a dependent one, because it varies necessarily with the type of engine.

Nascent State.—(See *State, Nascent*.)

Natural Currents.—(See *Currents, Natural*.)

Natural Law.—(See *Law, Natural*.)

Natural Magnet.—(See *Magnet, Natural*.)

Natural Unit of Electricity.—(See *Electricity, Natural Unit of*.)

Natural Unit of Quantity of Electricity, — (See *Electricity, Unit Quantity of, Natural*.)

Nautical Mile.—(See *Mile, Nautical*.)

Needle Annunciator.—(See *Annunciator, Needle*.)

Needle, Astatic — — A compound magnetic needle of great sensibility, possessing little or no directive power.

An astatic needle consisting of two separate magnetic needles, rigidly connected together and placed parallel and directly over each other, with opposite poles opposed.

An astatic needle is shown in Fig. 402. The two magnets N S, and S' N', are directly opposed in their polarities, and are rigidly connected together by means of the axis a, a. So disposed, the two magnets act as a very weak single needle when placed in a magnetic field.

Were the two magnets N S, and S' N', of exactly equal strength, with their poles placed in exactly the same vertical plane, they would completely neutralize each other, and the needle

would have no directive tendency. Such a system would form an *Astatic Pair* or *Couple*.

In practice it is impossible to do this, so that the

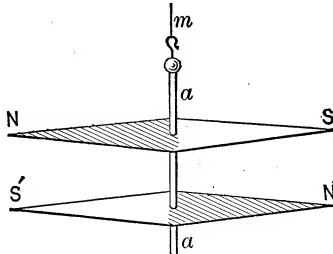

Fig. 402. Astatic Needle.

needle has a directive tendency, which is often east and west.

The cause of the east and west directive tendency of an unequally balanced astatic system will be understood from an inspection of Fig. 403. Unless the two needles, N S, and S' N', are exactly opposed, they will form a

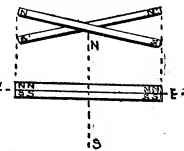

Fig. 403. Astatic Pair.

single short magnet, N N N N, S S S S, the poles of which are on the sides of the needle. The system pointing with its sides due north and south will appear to have an east and west direction.

The principal use of the astatic needle is in the *astatic galvanometer*, in which the needle is deflected by the passage of an electric current through a conductor placed near the needle.

Therefore it is evident that one of the needles must be outside and the other inside the coil. In the most sensitive form of galvanometer there is also a coil surrounding the upper needle, the two coils being oppositely connected, so that the deflection on both needles is in the same direction, and the deflecting

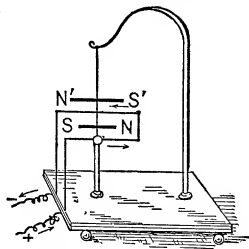

Fig. 404. Astatic System.

power is equal to the sum of the two coils, while the directive power of the needles is the difference of their magnetic intensities.

In the astatic system, as shown in Fig. 404, the current, which flows above one needle, flows below the other, and therefore deflects both needles

in the same direction, since their poles point in opposite directions.

In some galvanometers a varying degree of sensitiveness is obtained by means of a magnet, called a *compensating magnet*, placed on an axis above the magnetic needle. As the compensating magnet is moved towards or away from the needle the effect of the earth's field is varied, and with it the sensitiveness of the galvanometer. Such a magnet may form with the needle an astatic system. (See *Magnet, Compensating Galvanometer, Astatic Galvanometer, Mirror Multiplier, Schweigger's*).

Needle Electrode.—(See *Electrode, Needle*.)

Needle, Elongation of — —A phrase sometimes used for the angular deflection of a needle.

Needle, Magnetic — —A straight bar-shaped needle of magnetized steel, poised near or above its centre of gravity, and free to move either in a horizontal plane only, or in a vertical plane only, or in both.

A magnetic needle free to move in a vertical plane only is called a dipping needle. A magnetic needle free to move in a horizontal plane only, as shown in Fig. 405, is the form employed

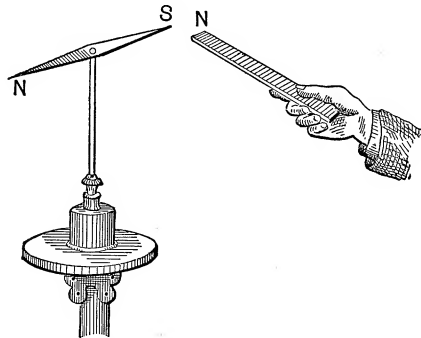

Fig. 405. Magnetic Needle.

in the mariner's compass. This form of magnetic needle is the one most commonly employed.

For use as a mariner's compass the needle is supported on gimbals and placed in a box provided with a card on which are marked the points of the compass. (See *Compass, Azimuth Compass, Points of*.)

Needle, Magnetic, Annual Variations of — —Variations in the value of the mag-

netic declination that take place at regular periods of the year.

The annual variations of the magnetic field were discovered by Cassini in 1786.

Needle, Magnetic, Daily Variation of

— — Variations in the value of the magnetic declination that take place at different periods of the day.

It was noticed, for example, in London that the north pole of the magnetic needle begins to move westward between 7 and 8 A. M. and continues this movement until 1 P. M., when it begins to move towards the east until near 10 P. M., when it again begins its westward course.

Needle, Magnetic, Damped — — A magnetic needle so placed as to quickly come to rest after it has been set in motion. (See *Damping*.)

Magnetic damping is readily effected by causing the needle to move near a metallic plate. On the motion of the needle the currents set up in the plate by dynamo-electric induction tend, according to Lenz's law, to oppose the motions producing them. (See *Induction, Electro-Dynamic Laws, Lenz's*.)

Needle, Magnetic, Declination of

— — The angular deviation of the magnetic needle from the true geographical north.

The variation of the magnetic needle.

The declination of the magnetic needle is either E. or W. (See *Declination, Angle of*.)

Declination, or variation, is different at different parts of the earth's surface.

Lines connecting places which have the same value and direction for the declination are called isogonal lines. A chart on which the isogonal lines are marked is called a variation chart.

The value of the declination varies at different times. These variations of the declination are:

(1.) *Secular*, or those occurring during great intervals of time. Thus, in London, in 1580 the magnetic needle had a variation of about 11 degrees east. This eastern declination decreased in 1622 to 6 degrees E., and in 1680 the needle pointed to the true north. In 1692 the declination was 6 degrees W.; in 1730, 13 degrees W.; in 1765, 20 degrees W.; and in 1818 the needle reached its greatest western declination and is

now moving eastwards. The declination, however, is still west.

(2.) *Annual*, the needle varying slightly in its declination during different seasons of the year.

(3.) *Diurnal*, the needle varying slightly in its declination during different hours of the day.

(4.) *Irregular*, or those which occur during the prevalence of a magnetic storm.

It has been discovered that the occurrence of a magnetic storm is simultaneous with the occurrence of an unusual number of sun spots. (See *Spots, Sun*.)

Needle, Magnetic, Deflection of

— — The movement of a needle out of a position of rest in the earth's magnetic field or in the field of another magnet, by the action of an electric current or another magnet.

The deflection of the needle is sometimes called its elongation. This latter term is, however, but little used, and is unnecessary.

Needle, Magnetic, Dipping — — A magnetic needle suspended so as to be free to move in a vertical plane, employed to determine the angle of dip or the magnetic inclination. (See *Dip, Magnetic, Inclination, Magnetic, Inclinator, Chart, Inclination*.)

A dipping needle is shown in Fig. 406. The

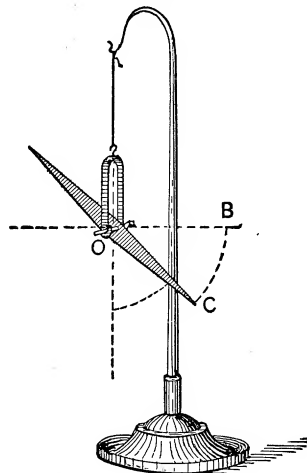

Fig. 406. Dipping Needle.

angle B O C, which marks the deviation of the needle from the horizontal position, is called the angle of dip.

Needle, Magnetic, Directive Tendency of — —The tendency of a magnetic needle to move so as to come to rest in the direction of the lines of the earth's magnetic field.

The directive power of the magnetic needle is due to the attraction of the earth's magnetic poles for the poles of the needle, or to the action of the earth's magnetic field. Since the force of the earth's magnetism forms a couple, there is no tendency for the needle to move bodily forward towards either of the earth's poles. Its tendency is merely to rotate until it comes to rest within the lines of the earth's magnetic field, entering at its south pole, passing through its mass and coming out at its north pole.

Of course this would be true in the case of a directing magnet only when it is at a great distance from the needle. Otherwise, there would be motion towards the poles as well as rotation.

Needle, Magnetic, Inclination or Dip of — —The deviation of a mechanically balanced magnetic needle from a horizontal position.

The direction of a magnetic needle in all parts of the earth, except at the magnetic equator, differs from a level or horizontal position. One of its ends inclines or dips towards the ground. (See *Dip, Magnetic. Needle, Magnetic, Dipping.*)

Needle, Magnetic, Orientation of — —The coming to rest of a magnetic needle in the earth's magnetic field.

Needle, Magnetic, Variation of — —The angular deviation of a magnetic needle from the true geographic north.

The declination of the magnetic needle. (See *Declination.*)

Needle of Oscillation.—A small magnetic needle employed for measuring the intensity of a magnetic field by counting the number of oscillations the needle makes in a given time, when disturbed from its position of rest in such field. (See *Magnetization, Intensity of. Lines, Isodynamic.*)

This use of a magnetic needle in determining the magnetic intensity of any place is analogous to the use of the pendulum in determining the intensity of gravity at any place.

Suppose, for example, that at a certain place the needle made 245 oscillations in ten minutes, and

that at another place it made 211 in the same time. Then the relative intensities at these two places would be as the square of these two numbers, or as 1 : 1.3482.

Needle, Telegraphic — —A needle employed in telegraphy to represent by its movements to the left or right respectively the dots and dashes of the Morse alphabet. (See *Telegraphy, Needle System of.*)

Needle, Throw of — —A phrase sometimes used for the angular deflection of a needle, particularly when the needle is swinging.

The displacement of the magnetic needle is called the deflection, the elongation, or the throw. The first will appear to be the preferable term when the needle comes to rest in a displaced position.

Negative Charge.—(See *Charge, Negative.*)

Negative Direction of Electrical Convection of Heat.—(See *Direction, Negative, of Electrical Convection of Heat.*)

Negative Direction of Simple-Harmonic Motion.—(See *Motion, Simple-Harmonic, Negative Direction of.*)

Negative Electricity.—(See *Electricity, Negative.*)

Negative Electrode.—(See *Electrode, Negative.*)

Negative Element of a Voltaic Cell.—(See *Element, Negative, of a Voltaic Cell.*)

Negative Feeders.—(See *Feeders, Negative.*)

Negative Omnibus Bars.—(See *Bars, Negative Omnibus.*)

Negative Phase of Electrotonus.—(See *Electrotonus, Negative Phase of.*)

Negative Plate of Storage Battery.—(See *Plate, Negative, of Storage Cell.*)

Negative Plate of Voltaic Cell.—(See *Plate, Negative, of Voltaic Cell.*)

Negative Pole.—(See *Pole, Negative.*)

Negative Potential.—(See *Potential, Negative.*)

Negative Side of Circuit.—(See *Circuit, Negative Side of.*)

Negative Wire.—(See *Wire, Negative*.)

Negatively.—In a negative manner.

Negatively Excited.—Charged with negative electricity. (See *Electricity, Negative*.)

Nerve or Muscular Fibre, Excitability of — (See *Excitability, Electric, of Nerve or Muscular Fibre*.)

Nerves, Action of Electricity on — Stimulating and other actions produced in nerves by the passage of electricity through them, dependent on the direction and character of the current. (See *Electrotonus, Galvanization, Faradization, Galvano-Faradization*.)

Net, Faraday's — An insulated net of cotton gauze, or other similar material, capable of being turned inside out without being thereby discharged, employed for demonstrating that in a charged, insulated conductor the entire charge is accumulated on the outer surface of the conductor.

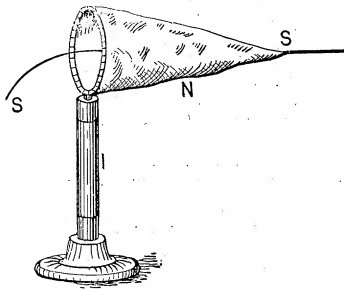

Fig. 407. Faraday's Net.

Faraday's net, as shown in Fig. 407, consists of a bag N, of cotton gauze, or mosquito netting, supported on an insulating stand I. When tested by a proof plane, no free electric charge is found on the inside, though such a charge is readily detected by the same means on the outside. By the aid of the silk strings S, S, the bag can be turned inside out, when the charge will then all be found on the then inside, or the now outside.

Faraday was in the habit of protecting his delicate electroscopes against outside electrification by covering them with gauze. To properly act as an electric screen, the gauze should be connected with the earth.

Faraday constructed a small insulated room,

twelve feet in height, breadth and depth, covered on the inside with tin-foil, and, on charging this room from the outside, he was unable to detect the presence of any charge on the inside, even by the aid of his most delicate instruments. This room is often referred to as Faraday's Cube.

Nets, Torpedo — Steel wire netting suspended from or attached to a ship's side for the purpose of ensuring protection against moving torpedoes.

Network of Currents.—(See *Currents, Network of, Laws, Kirchhoff's*.)

Neutral Armature.—(See *Armature, Neutral*.)

Neutral Feeder.—The feeder that is connected with the neutral or intermediate terminal of the dynamos in a three-wire system of distribution. (See *Feeders*.)

Neutral Line of Commutator Cylinder.—(See *Line, Neutral, of Commutator Cylinder*.)

Neutral Omnibus Bars.—(See *Bars, Neutral-Omnibus*.)

Neutral Point.—(See *Point, Neutral*.)

Neutral Points of a Dynamo-Electric Machine.—(See *Points, Neutral, of Dynamo-Electric Machine*.)

Neutral Points of Magnet.—(See *Points, Neutral, of Magnet*.)

Neutral Points of Thermo-Electric Diagram.—(See *Points, Neutral, of Thermo-Electric Diagram*.)

Neutral-Relay Armature.—(See *Armature, Neutral-Relay*.)

Neutral Section of Magnet.—(See *Section, Neutral, of Magnet*.)

Neutral Wire.—(See *Wire, Neutral*.)

Neutral Wire Ampère-Meter.—(See *Ampère-Meter, Balance or Neutral Wire*.)

New Ohm.—(See *Ohm, New*.)

Nickel Bath.—(See *Bath, Nickel*.)

Nickeling, Electro — Electroplating with nickel. (See *Plating, Electro*.)

Nickel-Plating.—(See *Plating, Nickel*.)

Night Bell.—(See *Bell, Night*.)

Nodal Point.—(See *Point, Nodal*.)

Nodes, Electrical — — Points in an open circuited conductor, through which electrical oscillations are passing, which possess a constant mean value of potential, while the potential at its ends alternates between two fixed limits.

Points on a conductor where the strength of the induced oscillatory current is equal to zero.

The nodal points on a conductor through which electrical oscillations are passing therefore correspond closely to the nodes on a vibrating wire or cord.

Dr. Hertz employed the following apparatus in order to show the position of two nodes in a conductor: An induction coil, A, had its secondary terminals connected as shown in Fig. 408,

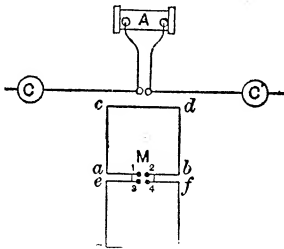

Fig. 408. Nodes in Conductor.

to two metallic spheres, C and C'. The spark micrometer circuit, a c d b, was placed near it, as shown, and the sparking distance of the secondary circuit of the induction coil adjusted, so that the spark micrometer circuit was in unison with it. When sparks were passed between the terminals of the induction coil A, sparks passed between the terminals 1 and 2, at M, under the influence of resonant action.

If, now, a second micrometer circuit, e g h f, exactly similar to a c d b, was added, as shown in the figure, and the two joined near the terminals 1 2 3 4, by conducting wires, as shown, the entire system of the micrometer circuit formed a closed metallic circuit, the fundamental vibration of which would have two nodes, one at the middle point of c d, and the other at g h. The internodes would be at the junctions 1 3, and 2 4, and under these circumstances a true resonant action existed between the secondary circuit and the micrometer circuit, as was shown by the fact that any alteration in the circuit e g h f, whether by

increasing or decreasing its length, diminished the sparking distance. Since the conductor connecting points 2, and 4, was in the position of the node, where the strength of the excited oscillatory current was zero, its removal from between these points should have no influence on the intensity of the vibration. This was found on trial to be the case. Electrical vibrations may therefore be excited by electrical resonance in conductors corresponding not only to the simple fundamental note or vibration, but also to the higher electrical overtones.

The apparatus shown in Fig. 409, from Tesla, illustrates the phenomena of alternative path, as well as electric nodes. The terminals of an induction coil are connected, as shown, to a condenser and to a thick copper conductor. Though the two incandescent lamps are placed as shown, yet they are raised to luminosity by a species of brush discharge that passes through them, although they would be short circuited to any current but an oscillatory discharge.

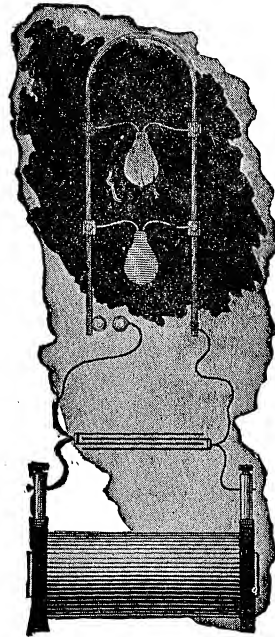

Fig. 409. Nodes in a Conductor.

Nodular Deposit, Electro-Metallurgical

— (See *Deposit, Electro-Metallurgical Nodular*.)

Noisy Arc.—(See *Arc, Noisy*.)

Nominal Candle-Power.—(See *Power, Candle, Nominal.*)

Non-Automatic Variable Resistance.—(See *Resistance, Variable, Non-Automatic.*)

Non-Conductors.—Substances that offer so great resistance to the passage of an electric current through their mass as to practically exclude a discharge passing through them.

Non-conductors are called insulators, because they electrically insulate substances placed on or surrounded by them.

The terms non-conductors or insulators are ordinarily used in a relative sense to mean bodies which allow no practical or appreciable current to pass through them, since there are no substances known, apart, perhaps, from the universal ether, that absolutely prevent the flow of an electric current, the difference of potential of which is sufficiently great.

The entire absence of ordinary matter, as in the case of a high vacuum, appears to render a high vacuum very nearly, if not entirely, an absolute insulator.

Non-Electrics.—A term formerly applied to substances like metals or other conductors which appeared not to become electrified by friction.

The term non-electric, was used in contradistinction to electrics, or substances readily electrified by friction. The distinction no longer holds, since non-electrics, if insulated, are readily electrified by friction.

Non-Homogeneous Current-Distribution.—(See *Current, Non-Homogeneous, Distribution of.*)

Non-Illumined Electrode.—(See *Electrode, Non-Illumined.*)

Non-Inductive Resistance.—(See *Resistance, Non-Inductive.*)

Non-Oscillatory Discharge.—(See *Discharge, Non-Oscillatory.*)

Non-Polarized Armature.—(See *Armature, Non-Polarized.*)

Non-Polarizable Electrodes.—(See *Electrodes, Non-Polarizable.*)

Non-Wasting Electrode.—(See *Electrode, Non-Wasting.*)

Normal Day, Magnetic — —(See *Day, Normal Magnetic.*)

Northern Light.—The Aurora Borealis. (See *Aurora Borealis.*)

Notation, Algebraic — —A system of arbitrary symbols employed in algebra.

The following brief description of the notation employed in algebra is for the use of the non-mathematical reader.

Quantities are represented in algebra by letters, such as a, and b, x, and y, etc.

Addition is represented thus: $a + b$.

Subtraction is represented thus: $a - b$.

Multiplication is represented thus: $a \times b$, or simply by writing the letters next to each other ab.

Division is represented thus: $a \div b$, or $\frac{a}{b}$

An Exponent, or figure placed to the right of a letter, above it as a^3 , indicates that the quantity represented by a, is to be multiplied by itself three times, as $a \times a \times a$, or a^3 .

A Co-efficient, or figure placed to the left of a quantity, indicates the number of times that quantity is to be taken; thus, $3a$, indicates that a is to be added three times, thus: $a + a + a$, or $3 \times a$.

A Radical Sign or Root, thus \sqrt{a} , or $^2\sqrt{a}$, indicates that the square root of the quantity a, is to be taken. In the same manner $\sqrt[3]{a}$, indicates that the cube root of a is to be taken.

These expressions are sometimes written $a^{\frac{1}{2}}$, or $a^{\frac{1}{3}}$.

Equality is indicated thus: $a^3 = a \times a \times a$, or $a^{\frac{1}{2}} = \sqrt{a}$.

A negative exponent a^{-2} indicates $\frac{1}{a^2}$, or is the exponent of the reciprocal of the quantity indicated.

Null or Zero Method.—(See *Method, Null or Zero.*)

Null Point.—(See *Point, Null.*)

Number, Diacritical — —Such a number of ampère-turns at which a given core would receive a magnetization equal to half saturation.

O

Ω .—A contraction for megohm. (See *Ohm, Meg.*)

ω .—A contraction for ohm. (See *Ohm.*)

Obscure Heat.—(See *Heat, Obscure.*)

Observation Mine.—(See *Mine, Observation.*)

Observatory, Magnetic — —An observatory in which observations of the variations in the direction and intensity of the earth's magnetic field are made.

Magnetic observatories are generally furnished with self-registering magnetic apparatus, such as *magnetographs, magnetometers, inclinometers.* (See *Magnetometer. Magnetograph. Inclinometer.*)

Magnetic observatories are generally constructed entirely of non-magnetic materials; that is, of such materials as are destitute of *paramagnetic properties.*

Obtuse Angle.—(See *Angle, Obtuse.*)

Occlusion of Gas.—(See *Gas, Occlusion of.*)

Odorscope.—An apparatus in which the determination of an odor was attempted by the measurement of the effect the odorous vapor, or effluvia, produced on a variable contact resistance.

The *microtasimeter* was used in connection with the odorscope. (See *Diagoneter, Rousseau's. Microtasimeter.*)

Oerstedt, An — —A proposed term for the unit of electric current, in place of an ampère.

The term has not been adopted.

Ohm.—The unit of electric resistance.

Such a resistance as would limit the flow of electricity under an electromotive force of one volt to a current of one ampère, or to one coulomb per second. (See *Unit, B. A. Ohm, Legal. Ohm, Standard.*)

A value equal to 10^9 absolute electro-magnetic units.

A value which is represented by a velocity of 10^7 , or 1,000,000,000 centimetres per second.

It may be difficult at first to see how resistance can be correctly represented by a velocity. The following consideration may render this clear: The formula for calculating the velocity is

$V = \frac{D}{T}$, or the velocity equals the distance passed through in unit time. Now, by examining the formula for the value of the resistance, expressed in terms of the electro-magnetic units (see *Units, Electro-Magnetic, Dimensions of*), it may be seen to be that resistance =

$$\frac{\text{Electromotive force}}{\text{Current}} = \frac{L}{T}$$

But this value is of the nature of a velocity, being equal to the length, divided by the time. Resistance, therefore, has the dimensions of a velocity.

This is clearly expressed by Silvanus P. Thompson in his "Elementary Lessons in Electricity and Magnetism," as follows, viz.: "Suppose we have a circuit composed of two horizontal coils, C S, and D T (Fig. 410), 1 centimetre apart, joined at C D, and completed by means of a sliding piece, A B. Let this variable circuit be placed in a uniform magnetic field of unit intensity, the lines of force being directed vertically downwards through the circuit.

"If, now, the slider be moved along towards S T, with a velocity of n , centimetres per second, the number of additional lines of force embraced by the circuit will increase at the rate of n , per second; or, in other words, there will be an *in-*

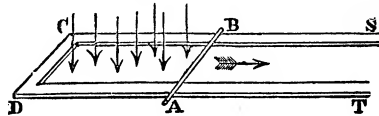

Fig. 410. Resistance as a Velocity.

duced electromotive force impressed upon the circuit, which will cause a current to flow through the slider from A to B. Let the rails have no resistance, then the strength of the current will depend on the resistance of A B. Now, let A B, move at such a rate that the current shall be of unit strength. If its resistance be one absolute (electro-magnetic) unit, it need only move at the rate of 1 centimetre per second. If its resistance be greater, it must move with a proportionately

greater velocity; the velocity at which it must move to keep up a current of unit strength being numerically equal to its resistance. *The resistance known as "1 ohm" is intended to be 10⁹ absolute electro-magnetic units, and, therefore, is represented by a velocity of 10⁹ centimetres, or 10,000,000 metres (1 earth-quadrant) per second.*

Ohm, B. A. — — A contraction for British Association ohm.

Ohm, Board of Trade — — A unit of resistance as determined by a committee of the English Board of Trade.

A committee consisting of Sir W. Thomson, Lord Rayleigh, Dr. J. Hopkinson and other authorities appointed by the Board of Trade (England) has recently recommended that the ohm be taken as the resistance of a column of mercury 106.3 centimetres in length and one square millimetre area of cross-section at 0 degrees C. and since this value agrees with the best experimental results, it will probably be generally and finally adopted.

Ohm, British Association — — The British Association unit of resistance, adopted prior to 1884.

The value of the unit of electric resistance, or the ohm, was determined by a Committee of the British Association as being equal to the resistance at 0 degree C. of a column of mercury 1 square millimetre in area of cross-section and 104.9 centimetres in length. This length was taken as coming nearest the value of the true ohm deduced experimentally from certain theoretical considerations. Subsequent re-determinations showed the value so obtained to be erroneous.

The value of the ohm is now taken internationally, as adopted by the International Electric Congress in 1884, as the resistance of a column of mercury 106 centimetres in length, and 1 square millimetre in area of cross-section. This last value is called the *legal ohm*, to distinguish it from the B. A. ohm, which, as above stated, is equal to a mercury column 104.9 centimetres in length. Usage now sanctions the use of the word *ohm* to mean the legal ohm.

This value of the legal ohm is provisional until the exact length of the mercury column can be finally determined. (See *Ohm, Board of Trade.*)

The following are the relative values of these units, viz.:

- 1 legal ohm..... = 1.0112 B. A. ohm.
- “ “ = 1.0600 Siemens unit.
- 1 B. A. ohm..... = .9889 legal ohm.
- 1 “ “ = 1.0483 Siemens unit.
- 1 Siemens unit.... = .9540 B. A. ohm.
- “ “ = .9434 legal ohm.

Ohm, Legal — — The resistance of a column of mercury 1 square millimetre in area of cross-section, and 106 centimetres in length, at the temperature of 0 degree C. or 32 degrees F. (See *Unit, B. A.*)

1 ohm = 1.00112 B. A. units. This value of the ohm was adopted by the International Electric Congress, in 1884, as a value that should be accepted internationally as the true value of the ohm. This value, however, was provisional, and was never actually legalized. It will probably be replaced by the new (106.3 cm.) ohm. (See *Ohm, Board of Trade.*)

Ohm, Meg — — One million ohms.

Ohm, New — — A term sometimes used for the Board of Trade ohm. (See *Ohm, Board of Trade.*)

Ohm, Standard — — A length of wire having a resistance of the value of the true or legal ohm, employed in standardizing resistance coils.

The standard ohm, as issued by the Electric Standards Committee of England, has the form

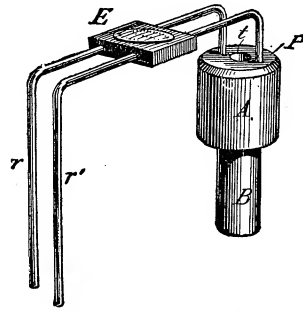

Fig. 411. Standard Ohm.

shown in Fig. 411. The coil of wire is formed of an alloy of platinum and silver, insulated by silk covering and melted paraffine. Its ends are soldered to thick copper rods *r*, *r'*, for ready connection with mercury cups. The coil is at *B*. The space above it at *A*, is filled with paraffine, except at the opening *t*, which is provided for the insertion of a thermometer.

Ohm, True — — An ohm having the true theoretical value of the ohm. (See *Ohm*.)

Ohmage.—The value of the resistance of a circuit expressed in ohms.

Ohmic Resistance. — (See *Resistance, Ohmic or True*.)

Ohmmeter.—A commercial galvanometer, devised by Ayrton, for directly measuring by the deflection of a magnetic needle, the resistance of any part of a circuit through which a strong current of electricity is flowing.

Ayrton's *ohmmeter* is represented diagrammatically in Fig. 412. Two coils C C, and c c,

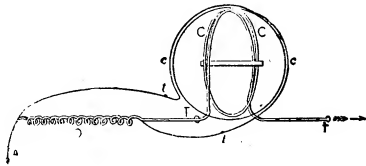

Fig. 412. Ayrton's Ohmmeter.

consisting of a short thick wire, and a long thin wire, respectively, are placed at right angles to each other, and act on a *soft iron needle* situated as shown. The short, thick wire coil C C, is connected in *series* with the resistance O, to be measured. The long, fine wire coil, of *known high resistance*, is placed as a *shunt* to the unknown resistance.

Under these circumstances, it can be shown that the action on the needle is that due to the ratio of the difference of potential at the terminals of the unknown resistance and the current strength in the thick wire coil, or $R = \frac{E}{C}$, as may be deduced from Ohm's law.

The coils are so proportioned that the current when flowing through the short thick wire moves the needle to the zero of the scale, while the long thin wire produces a deflection directly proportional to the resistance.

Ohm's Law.—(See *Law of Ohm*.)

Oil, Colza — — An oil obtained from the seed of the *Brassica oleracea*, a species of cabbage.

Colza oil is extensively used for purposes of illumination and in the carcel standard lamp. (See *Lamp, Carcel*.)

Oil Cup.—A cup containing oil for lubricating machinery.

Oil Insulator.—(See *Insulator, Oil*.)

Oil Transformer.—(See *Transformer, Oil*.)

Oiler, Automatic — — An oil cup or reservoir that automatically spreads oil over the bearings of machinery in motion.

Okonite.—A variety of insulating material.

Omnibus Bars.—(See *Bars, Omnibus*.)

Omnibus Wires.—(See *Wires, Omnibus*.)

Opacity, Selective — — Opaque in a certain direction or directions only.

Certain substances are opaque to polarized light in certain planes only. Thus, a plate of tourmaline permits light polarized in a certain plane freely to pass through it, but is entirely opaque in a plane at right angles thereto.

S. P. Thompson and Lodge have shown that such crystals of tourmaline possess curious properties in regard to the conduction of heat. While warming, the crystal conducts heat better in a certain direction than in the opposite direction. While cooling, exactly the opposite effects are observed. In the same manner, while the crystal is rising in temperature, there is an accumulation of positive electricity at one end, and negative at the other. While the crystal is cooling, the reverse is true.

Open-Box Conduit.—(See *Conduit, Open-Box*.)

Open Circuit.—(See *Circuit, Open*.)

Open-Circuit Electric Oscillations.—(See *Oscillations, Open-Circuit, Electric*.)

Open-Circuit Induction.—(See *Induction, Open-Circuit*.)

Open-Circuit Oscillation, Period of — — The time in which the oscillations set up in a circuit by electrical resonance require to make a complete one to-and-fro motion.

The period of an open-circuit electric oscillation is determined by the product of the coefficients of self-induction of the conductor, and does not depend on the composition of the terminals. It is practically independent of their resistances.

Open-Circuit Single-Current Signaling.—(See *Signaling, Single-Current, Open-Circuit*.)

Open-Circuit Voltaic Cell.—(See *Cell, Voltaic, Open-Circuit.*)

Open-Circuit Voltmeter.—(See *Voltmeter, Open-Circuit.*)

Open-Circuited.—Put on an open circuit.

Open-Circuited Conductor.—(See *Conductor, Open-Circuited.*)

Open-Circuited Thermostat.—(See *Thermostat, Open-Circuit.*)

Open-Coil Drum Dynamo-Electric Machine.—(See *Machine, Dynamo-Electric, Open-Coil Drum.*)

Open-Coil Dynamo-Electric Machine.—(See *Machine, Dynamo-Electric, Open-Coil.*)

Open-Coil Ring Dynamo-Electric Machine.—(See *Machine, Dynamo-Electric, Open-Coil Ring.*)

Open-Iron-Circuit Transformer.—(See *Transformer, Open-Iron-Circuit.*)

Open-Iron Magnetic Circuit.—(See *Circuit, Open-Iron Magnetic.*)

Open Magnetic Core.—(See *Core, Open-Magnetic.*)

Opening Shock.—(See *Shock, Opening.*)

Operation, Magnet — —The use of a magnet for the purpose of removing particles of iron from the human eye.

Optical Strain.—(See *Strain, Optical.*)

Optical Strain, Electro-Magnetic — —(See *Strain, Optical Electro-Magnetic.*)

Optical Strain, Electrostatic — —(See *Strain, Electrostatic, Optical.*)

Optics, Electro — —That branch of electricity which treats of the general relations that exist between light and electricity.

The phenomena of electro-optics may be arranged under the following heads, viz.:

(1.) Electrostatic stress, produced by an electrostatic field causing an optical strain in a transparent medium, whereby such medium acquires the property of either rotating the plane of polarization of a beam of plane polarized light, or of doubly refracting light.

(2.) Electro magnetic stress produced by a

magnetic field causing an optical strain in a transparent medium, whereby such medium acquires the property of either rotating the plane of polarization, or of doubly refracting light. (See *Refraction, Double, Electric.*)

(3.) Changes in the electric resistance of bodies caused by the action of light. (See *Cell, Selenium.*)

(4.) The relation existing between the values of the index of refraction of a transparent medium and its specific inductive capacity. (See *Refraction. Capacity, Specific Inductive.*)

This relation has been shown to be as follows:

The specific inductive capacity is approximately equal to the square of the index of refraction.

(5.) The relation existing between the velocity of light and the value of the ratio of electrostatic and the electro-magnetic units, thus giving a basis for an electro-magnetic theory of light. (See *Light, Maxwell's Electro-Magnetic Theory of.*)

Polarized light reflected from the surface of a magnet, although it penetrates the substance to but a trifling extent, yet has its plane of polarization distinctly rotated by the magnetic whirls in the iron.

Oral or Speaking-Tube Annunciator.—(See *Annunciator, Oral or Speaking-Tube.*)

Ordinate.—A distance taken on a perpendicular line called the axis of ordinates, in contradistinction to the axis of abscissas. (See *Ordinates, Axis of.*)

Thus in Fig. 413, D 1, is the ordinate of the point D, in the curve O D R.

Ordinates, Axis of — —One of the axes of co-ordinates used for determining the position of the points in a curved line.

Thus in Fig. 413 the line A B, is called the axis of ordinates because it is the line on which the ordinate 2 D, is measured.

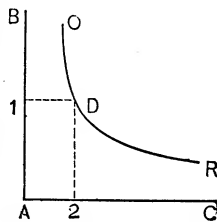

Fig. 413. Axis of Ordinates.

Ores, Electric Treatment of — —Processes for the extraction of metals from their ores.

These processes are referable to three distinct classes, viz.:

(1.) Those in which the reduction is effected by means of heat of electric origin.

(2.) Those in which the reduction is effected by the combined action of heat and electrolysis.

(3.) Those in which the reduction is effected by means of electrolysis only.

Organ, Electric — —A wind organ, in which the escape of air into the different pipes is electrically controlled.

In an electric organ, the keys, instead of operating levers, as usual, to admit the passage of air into the pipes, merely complete the circuit of a battery through a series of controlling electro-magnets. With such an arrangement, the keyboard can be placed at any desired distance.

Electric organs have been constructed, in which a chemical or mechanical record is made of the notes struck by the performer, as well as the musical value of such notes. By such a device the musical creations of a composer are permanently recorded in characters that are capable of interpretation by a compositor skilled in musical notation.

Orientation of Magnetic Needle.—(See *Needle, Magnetic, Orientation of.*)

Origin, Point of — —The point where the axes of co-ordinates start or originate. (See *Co-ordinates, Axes of.*)

Orthogonal.—Rectangular, or right-angled.

Oscillating Discharge.—(See *Discharge, Oscillating.*)

Oscillating Needle.—(See *Needle of Oscillation.*)

Oscillation, Centre of — —A point in a body swinging like a pendulum, which is neither accelerated nor retarded, during its oscillations, by the portions of the pendulum that are situated respectively above or below it.

If all the mass were concentrated at the centre of oscillation the time of oscillation would be the same.

The centre of oscillation is always below the centre of gravity. The vertical distance between the centre of oscillation and the point of support of a pendulum, determines the *virtual length* of the pendulum, and hence its number of vibrations per second. (See *Pendulum, Laws of.*)

Oscillations, Electric — —The series of partial, intermittent discharges of which the apparent instantaneous discharge of a Leyden jar through a small resistance actually consists.

These partial discharges produce a series of electric oscillations of the current in the circuit of the discharge, which consist of true to-and-fro or backward-and-forward motions of the electricity. This phenomenon was discovered by Joseph Henry.

Oscillations, Open-Circuit, Electric — —Electric oscillations produced in open circuits by the presence of electric pulses in neighboring circuits.

Oscillatory Discharge.—(See *Discharge, Oscillatory.*)

Oscillatory Electric Displacement.—(See *Displacement, Electric, Oscillatory.*)

Oscillatory Electromotive Force.—An electromotive force which is rapidly periodic.

Oscillatory Inductance.—(See *Inductance, Oscillatory, Electric.*)

Oscillatory Induction.—(See *Induction, Oscillatory.*)

Osmose.—The unequal mixing of liquids of different densities through the pores of a separating medium.

If a solution of sugar and water be placed in a bladder, the neck of which is tied to a straight glass tube, and the bladder is then immersed in a vessel of pure water with the tube in a vertical position, the two liquids will begin to mix, the sugar and the water passing through the bladder into the pure water, and the pure water passing into the sugar and water in the bladder. This latter current is the stronger of the two, as will be shown by the water *rising* in the vertical glass tube.

The stronger of the two currents, that is, the one directed towards the higher level, or the one which produces the higher level, is called the *endosmotic current*, and the weaker current the *exosmotic current*.

Osmose, Electric — —A difference of liquid level between two liquids placed on opposite sides of a diaphragm produced by the passage of a strong electric current

through the liquids between two electrodes placed therein.

The higher level is on the side towards which the current flows through the diaphragm, thus apparently indicating an onward motion of the liquid with the current, or, in other words, the liquid is higher around the cathode than around the anode. The difference of level is most marked when poorly conducting liquids are employed.

As a converse of this, Quincke has shown that electric currents are set up when a liquid is forced by pressure through a porous diaphragm. The term *diaphragm currents* has been proposed for these currents. Their electromotive force depends on the nature of the liquid, on the material of the diaphragm, and on the pressure that forces the liquid through the diaphragm. (See *Phenomena, Electro-Capillary. Currents, Diaphragm.*)

Osmotic.—Of or pertaining to osmose. (See *Osmose.*)

Osteotome, Electric — — A revolving electrically propelled saw, employed in the surgical cutting of bones.

An electric osteotome consists essentially of a form of revolving engine known as a dental engine, furnished with a circular saw, or other rotary cutter, driven or propelled by electricity.

Outgoing Current.—(See *Current, Outgoing.*)

Outlet.—In a system of incandescent lamp distribution the places in a building where the fixtures or lamps are attached.

The outlets are left in a building by the wireman for the electric fixtureman to attach the device intended to be used on the circuits so provided.

Output, Magnetic — — The product of the magnetic flux by the magneto-motive force.

Output of Dynamo-Electric Machine.—(See *Machine, Dynamo-Electric, Output of.*)

Outrigger for Electric Lamp.—A device for suspending an electric arc lamp so as to cause it to stand out from the wall of a building.

An outrigger and hood with lamp attached are shown in Fig. 414.

Outrigger Torpedo.—(See *Torpedo, Outrigger.*)

Over-Compounded.—The compounding of a dynamo-electric machine so as to produce

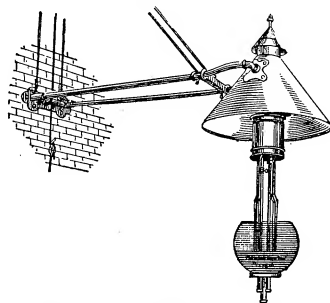

Fig. 414. Outrigger and Hood.

an increase of voltage under increase of load.

Over-compounding is generally employed for compensating for drop or loss of potential in the line or conductor, and is adjusted to a definite percentage of increase from light to full load in accordance with the amount of drop, or loss, for which such compensation was designed.

Overhead Lines.—(See *Lines, Overhead.*)

Overhead System, Continuous, of Motive Power for Electric Railroads — — (See *Railroads, Electric, Continuous Overhead System of Motive Power for.*)

Overload of Electric Motor.—(See *Motor, Electric, Overload of.*)

Overtones.—Additional, faint tones, accompanying nearly every distinct musical tone, by the presence of which the peculiarity or quality of such tone is produced. (See *Sound, Characteristics of.*)

Overtones, Electric — — Electric vibrations produced in open-circuited conductors by electric resonance, of higher rates than the fundamental vibrations.

The existence of electrical overtones necessitates the existence of electric nodes. (See *Nodes, Electrical.*)

Overtone Dynamo.—(See *Dynamo, Overtone.*)

Ozite.—An insulating substance.

Ozokerite.—An insulating substance.

Ozone.—A peculiar modification of oxygen which possesses more powerful oxidizing properties than ordinary oxygen.

Ozone is now generally believed to be triatomic oxygen, or oxygen in which the bonds are closed, thus:



The peculiar smell observed when a torrent of electric sparks passes between the terminals of a Holtz machine, or a Ruhmkorff coil, is caused by the ozone thus formed.

In a similar manner ozone is formed in the at-

mosphere during the passage through the air of a flash of lightning.

During the so-called electrolysis of water, a compound formed by the union of two volumes of hydrogen with one volume of oxygen, some of the oxygen is given off in the form of ozone. Since ozone has a somewhat smaller volume than that of the oxygen forming it, the volume of the oxygen liberated is somewhat less than half the volume of the hydrogen.

There are a number of different forms of apparatus designed for the production of ozone. They consist essentially either of means for passing a torrent of electric sparks through air or for producing a species of polarization in the air.

P

P. D. or p. d.—A contraction frequently employed for difference of potential. (See *Potential, Difference of*.)

Pacinotti Projections.—(See *Projections, Pacinotti*.)

Pacinotti Ring.—(See *Ring, Pacinotti*.)

Pair, Astatic — —A term sometimes applied to an astatic couple. (See *Couple, Astatic*.)

Palladium.—A metal of the platinum group.

Metallic palladium has a tin-white color, and, when polished, a high metallic lustre. It is tenacious and ductile, and, like iron, can be welded at a white heat. It is very refractory and possesses in a marked degree the power of absorbing or occluding hydrogen and other gases. It is not affected by oxygen at any temperature, nor readily affected by ordinary corrosive agents.

Palladium Alloy.—(See *Ally, Palladium*.)

Pane, Magic — —A condenser formed of a sheet of glass covered on one side with pieces of tin-foil with small spaces between them pasted in some design on the glass.

On the discharge of a Leyden jar through these metallic pieces, the design is seen as a series of minute sparks, which bridge the spaces between the adjacent pieces of foil.

Pantelegraphy.—A system for the telegraphic transmission of charts, diagrams, sketches or written characters.

Pantelegraphy is more frequently called facsimile telegraphy. (See *Telegraphy, Fac-Simile*.)

Paper Carbons.—(See *Carbons, Paper*.)

Paper Cut-Out.—(See *Cut-Out, Paper*.)

Paper Perforator.—(See *Perforator, Paper*.)

Paper Winder, Automatic — —A device, driven by clockwork, for automatically delivering the paper fillet on which a telegraphic message is received.

Parabolic Reflector.—(See *Reflector, Parabolic*.)

Paraffine.—A name given to various solid hydrocarbons of the marsh gas series, that are derived from coal oil or petroleum by the action of nitric acid.

Paraffine possesses excellent powers of insulation, and forms a good dielectric medium. Dried wood, boiled in melted paraffine, forms a fair insulating material.

Paraffine Wire.—(See *Wire, Paraffine*.)

Paraffining.—Covering or coating with paraffine.

The paraffine is applied, while melted by heat, either by means of a brush, or by dipping the article in the fused mass.

Care must be taken in paraffining wooden or other absorbent articles, to dry them before immersing in the melted paraffine, since, if water be present, steam is formed explosively, and the melted paraffine scattered in all directions.

Paragrêles.—Lightning rods, intended to protect fields against the destructive action of hail. (See *Hail, Assumed Electrical Origin of.*)

It was formerly believed that hail is caused by electricity. It is now generally believed that the electricity in hail storms is caused by the hail. It will, therefore, readily be understood that paragrêles can afford no real protection.

Parallax.—The apparent angular displacement of an object when seen from two different points of view.

In reading the exact division on a scale to which a needle points, care must be taken to look directly down on the needle, and not sideways, so as to avoid the error of displacement due to *parallax*.

Parallel Circuit.—(See *Circuit, Parallel.*)

Parallel Series.—(See *Series, Parallel.*)

Parallelogram of Forces.—(See *Forces, Parallelogram of.*)

Parallels, Magnetic — — Lines connecting places on the earth's surface at right angles to the isogonal lines, or lines of equal declination or variation.

The magnetic parallels are at right angles to the magnetic meridians. The magnetic parallels lie in planes parallel to the magnetic equator. (See *Needle, Magnetic, Declination of. Meridian, Magnetic.*)

Paramagnetic.—Possessing properties ordinarily recognized as magnetic.

Possessing the power of concentrating the lines of magnetic force.

Paramagnetic is a term employed in contradistinction to *diamagnetic*. (See *Diamagnetic.*) A paramagnetic substance, cut in the form of a bar whose length is much greater than its breadth and thickness, will, when suspended in a magnetic field in the manner shown in Fig. 415, take up a position of rest with its *greatest length in the direction of the lines of force, i. e., will point axially.*

In other words, the lines of force will so pass through the paramagnetic substance as to reduce the *magnetic resistance* of the circuit as much as possible.

Paramagnetic substances, therefore, concentrate the lines of force on them. (See *Resistance, Magnetic.*)

Diamagnetic substances, on the contrary, when placed as shown in Fig. 415, assume a position of rest with their *least dimensions in the direction of the lines of force, i. e.,*

they point equatorially.

This is the position in which they are placed by the lines of force, in order to insure the *least magnetic resistance* in the circuit of these lines.

The magnetic resistance of diamagnetic substances is great as compared with that of paramagnetic substances.

The term *ferro-magnetic* has been proposed for *paramagnetic*. If

another term be required, which is doubtful, *sidero-magnetic*, proposed by S. P. Thompson, would appear to be preferable. (See *Magnetic, Ferro. Magnetic, Sidero.*)

Tyndall believes that the magnetic polarity possessed by diamagnetic substances is the result of a distinct polar force, different in its nature from ordinary magnetism. His views, in this respect, are not generally accepted. (See *Polarity, Diamagnetic.*)

Paramagnetically.—In a paramagnetic manner. (See *Paramagnetism.*)

Paramagnetism.—The magnetism of a paramagnetic substance.

Parasitical Currents.—(See *Currents, Parasitical.*)

Paratonnère.—A French term for lightning rod, sometimes employed in English technical works.

Lightning rod would appear to be the preferable term.

Partial Contact.—(See *Contact, Partial.*)

Partial Disconnection.—(See *Disconnection, Partial.*)

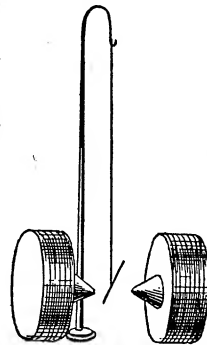

Fig. 415. Diamagnetic Polarity

Partial Earth.—(See *Earth, Partial*.)

Partial Reaction of Degeneration.—(See *Degeneration, Partial Reaction of*.)

Passive State.—(See *State, Passive*.)

Path, Alternative — —The path or circuit taken by an impulsive discharge, in preference to another path or circuit, open to the discharge, although of enormously smaller ohmic resistance.

The alternative path is the path taken by the discharge produced by what was formerly called lateral induction.

The explanation of the reason the discharge takes the alternative path is that the counter-electromotive force of self-induction of the circuit, produced by the impulsive discharge, is so great as to make the path of the circuit itself, although formed of conducting materials, practically non-conducting.

If a Leyden jar is provided with discharge wires or conductors, as shown in Fig. 416, a discharge

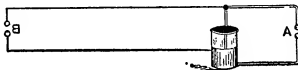

Fig. 416. Phenomena of Alternative Path.

taking place at A, is accompanied simultaneously by an even longer spark at B, between the ends of two long open-circuit leads.

To explain in a general manner the phenomena of the alternative path, we may say that the discharge at A, gives rise to electric oscillations in the leads connected with B, and that there are sent out into the surrounding medium radiations of precisely the same nature as those which produce light, only of a wave length so long as to be unable to produce on the eye the effects of light.

If the space between the balls at B, is too great for the discharge to take place, the wires glow and throw out minute sparks or brushes of light.

The action of the ordinary lightning arrester depends on the principle of the alternative path. The resistance of the metallic circuit, composed of the line and the instruments, is so great in the case of the impulsive discharge of a lightning flash, that the discharge takes place between a series of points connected with the line plate and another series of points connected with the ground plate. (See *Arrester, Lightning*.)

Dr. Lodge, who has studied the principle of alternative path in the case of lightning rods, finds that the distance at which the discharge

would pass across an air space in preference to a metallic circuit, was greater for a thick copper

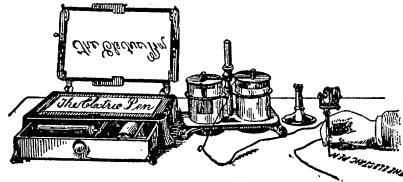

Fig. 417. Edison Electric Pen.

rod, 40 feet long, than for an iron rod of No. 27 B. W. G. of 33.03 ohmic resistance.

Patrol Alarm Box.
—(See *Box, Patrol Alarm*.)

Peltier Effect. —
(See *Effect, Peltier*.)

Pen Carriage. —
(See *Carriage, Pen*.)

Pen, Electric —
—A device for manifold copying, in which a sheet of paper is made into a stencil by minute perforations obtained by a needle driven by a small electric motor and the stencil afterwards employed in connection with an inked roller for the production of any required number of copies.

Mechanical pens are constructed on the same principle, the perforations being obtained by mechanical instead of by electric power.

In the Edison electric pen, Fig. 417, the perforations are made by an electric motor driven by a voltaic battery. The manifold press with its inked pad is shown to the left of the figure.

Pendant Cord.—(See *Cord, Pendant*.)

Pendant, Electric — —A hanging fix-

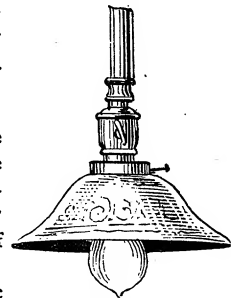
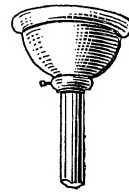

Fig. 418. Electric Pendant.

ture provided with a socket for the support of an incandescent lamp.

A form of electric pendant is shown in Fig. 418.

Pendant, Flexible Electric Light —

—A pendant for an incandescent lamp formed by the flexible conductors which support the lamp.

The advantages procured by a flexible pendant are evident in that both the length of the flexible conductor from which the lamp is hanging and position of the lamp can be changed considerably.

Pendulum Annunciator.—(See *Annunciator, Pendulum or Swinging*.)

Pendulum, Electric — —A pendulum so arranged that its to-and-fro motions send electric impulses over a line, either by making or breaking contacts.

An electrical tuning fork whose to-and-fro movements are maintained by electric impulses.

Electric pendulums are employed in systems for the electrical distribution of time.

Sometimes instead of using true pendulums for such purposes, coils, mounted on tuning forks, or on the ends of flexible bars of steel, called reeds, are used for the purpose of establishing currents, or modifying the currents that are already passing in a circuit. The movement of a magnetic diaphragm, as in the case of a telephone diaphragm, towards and from a coil of wire, is another illustration of an electric pendulum.

Electric tuning-fork pendulums are employed in Delany's system of synchronous-multiplex telegraphy, and in Gray's harmonic-multiple telegraphy. (See *Telegraphy, Synchronous-Multiplex, Delany's System. Telegraphy, Gray's Harmonic-Multiple*.)

Pendulum, Laws of — —The laws which express the peculiarities of the motion of a simple pendulum.

A simple pendulum is one in which the entire weight is considered as concentrated at a single point, suspended at the end of a weightless, inflexible and inextensible line.

The following are the laws of the simple pendulum :

(1.) Oscillations of small *amplitude* are approximately *isochronous*; that is, are made in times that are sensibly equal. (See *Vibration or Wave, Amplitude of. Isochronism*.)

(2.) In pendulums of different lengths, the duration of the oscillations is proportional to the square root of the length of the pendulum.

(3.) In the same pendulum, the length being preserved invariable, the duration of the oscillation is inversely proportional to the square root of the intensity of gravity.

The *intensity of gravity*, at any latitude, may be determined by the number of oscillations of a pendulum of a given length. In the same manner the *intensity of a magnetic field*, or the *intensity of magnetization* of a magnet, may be determined by the *needle of oscillation*, by observing the number of oscillations a needle makes in a given time when disturbed from its position of rest. (See *Needle of Oscillation*.)

Since a simple physical pendulum is a physical impossibility, the *virtual length* of a pendulum, that is, the vertical distance between its point of support and the *centre of oscillation*, is taken as the true length of the pendulum.

If the irregularly shaped body, shown in Fig. 419, whose centre of gravity is at G, is made to swing like a pendulum, either on S, or O, its oscillations will be performed in equal times, and the body will act as a simple pendulum, whose virtual length is S O.

If, while suspended at S, it be struck at O, it will oscillate around S, without producing any pressure on the supporting axis at S, on which it turns. If floating entirely submerged in a liquid, a blow at O, would cause it to move in a straight line in the direction of the blow, without rotation.

The point O, is called the *centre of percussion*, or the *centre of oscillation*. The centre of oscillation is always below the *centre of gravity*.

Pentane Standard.—(See *Standard, Pentane*.)

Percussion, Centre of — —That point in a body suspended so as to move as a pendulum at which a blow would produce rotation, but no forward motion, or motion of translation.

Perforator, Paper — —An apparatus employed in systems of automatic telegraphy for punching in a fillet of paper the circular or elongated spaces that produce the dots and

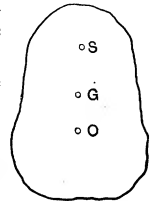

Fig. 419. *Centre of Oscillation.*

dashes of the Morse alphabet, when the fillet is drawn between metal terminals that form the electrodes of a battery. (See *Telegraphy, Automatic.*)

Perforator, Pneumatic — —A paper perforator operated by means of compressed air. (See *Perforator, Paper.*)

Period of Open-Circuit Oscillation.—(See *Open-Circuit Oscillation, Period of.*)

Period of Simple-Harmonic Motion.—(See *Motion, Simple-Harmonic, Period of.*)

Period of Vibration.—(See *Vibration, Period of.*)

Period, Vibration — —The period of a single or a whole vibration in a conductor, in which an oscillatory vibration is being produced by electrical resonance when responding to its fundamental vibration.

Hertz gives the following value for the vibration period: Calling T, the single or half vibration period; L, the co-efficient of self-induction in absolute magnetic measure, and therefore expressed in centimetres; C, the capacity of the terminals, in electrostatic measure, and therefore also expressed in centimetres; v, the velocity of light in centimetre-seconds, then, when the resistance of the conductor is small, $T = \pi \frac{\sqrt{LC}}{v}$.

Periodic and Alternate Discharge.—(See *Discharge, Periodic. Discharge, Alternating.*)

Periodic Current, Power of — —The rate of transformation of the energy of a circuit traversed by a simple periodic current.

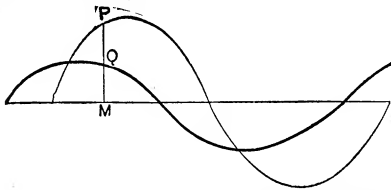

Fig. 420. Power of Periodic Current.—(Fleming.)

If the thin line in the curve, Fig. 420, represents the impressed electromotive force in an inductive circuit, and the thick line the corresponding current, then, at any instant, say at the point M, the rate at which energy is being expended on the circuit, is equal to the ordinate P M, multiplied by the ordinate Q M. The mean power is

the mean of all such products taken at points of time very near together.

The power of a periodic current, or the work expended per second on such a circuit, is equal to half the product of the maximum values of the current, at any instant, and the maximum value of the impressed electromotive force, multiplied by the cosine of the angle of lag.

Periodic Governor.—(See *Governor, Periodic.*)

Periodically Decreasing Discharge.—(See *Discharge, Periodically Decreasing.*)

Periodicity.—The rate of change in the alternations or pulsations of an electric current.

Periodicity of Auroras and Magnetic Storms.—(See *Auroras and Magnetic Storms, Periodicity of.*)

Permanency, Electric — —The property possessed by most metallic substances, while in the solid state, of retaining a constant electric conducting power at the same temperature.

The electric permanency of hard drawn wire is small, since such wire becomes gradually annealed, and thus changed in its electric resistance.

Matthiessen showed that some specimens of annealed German silver wire increased in their conducting power at the rate of about .02 per cent. yearly.

Permanent Intensity of Magnetization.—(See *Magnetization, Permanent, Intensity of.*)

Permanent Magnet Voltmeter.—(See *Voltmeter, Permanent Magnet.*)

Permanent State of Charge on Telegraph Line.—(See *State, Permanent, of Charge on Telegraph Line.*)

Permeability Curve.—(See *Curve, Permeability.*)

Permeability, Magnetic — —Conductibility for lines of magnetic forces.

The ratio existing between the magnetization produced, and the magnetizing force producing such magnetization.

If μ equals the permeability, **B**, the magnetiza-

tion produced, or the intensity of magnetic induction, and H , the magnetizing force; then,

$$\mu = \frac{B}{H}$$

The permeability of non-magnetic materials, such as insulators, or non-magnetic metals, such as copper, etc., is assumed to be practically equal to that of air, or to unity.

The magnetic permeability decreases as the magnetization increases. When a piece of iron has been magnetized up to a certain intensity, its permeability becomes less for any further magnetization; or, the substance shows a tendency to reach magnetic saturation. In good iron, this limit is reached at about 125,000 lines of force to the square inch of area of cross section.

The magnetic permeability varies greatly, not only with different specimens of iron, but also with the previous history of the iron, as to whether or not it has before been subjected to magnetization or demagnetization, and also as to whether the value of the permeability is taken while the magnetization is increasing or decreasing.

Permeameter.—An apparatus devised by S. P. Thompson, for roughly measuring the magnetic permeability.

Thompson's permeameter consists essentially of a rectangular piece of soft iron, provided with a slot, for the reception of the magnetizing coil. A hole bored in one end of the block serves to receive the bar or rod of iron whose permeability is to be determined. On the magnetization of the bar to be tested, the square root of the force required to detach the rod from the lower surface of the iron block, is a measure of the permeation of the lines of magnetic forces through its end faces.

Permeance, Magnetic — —Magnetic permeability. (See *Permeability, Magnetic*.)

Permeating, as of Lines of Force.—The passing of lines of force through a magnetic substance. (See *Permeability, Magnetic*.)

Permeation, Magnetic — —The passage of lines of magnetic force through any permeable substance.

Permissive Block System for Railroads.—(See *Railroads, Permissive Block System for*.)

Pflüger's Law.—(See *Law, Pflüger's*.)

Phantom Wires.—(See *Wires, Phantom*.)

Phase, Angle of Difference of, between Alternating Currents of Same Period — — The angle which measures the shifting of phase of a simple periodic current with respect to another due to lag or other cause.

Phase, Shifting of, of Alternating Current — —A change in phase of current due to magnetic lag or other causes.

Phase of Vibration.—(See *Vibration, Phase of*.)

Phelps' Stock Printer.—(See *Printer, Stock, Phelps'*.)

Phenomena, Electro-Capillary — — Phenomena observed in capillary tubes at the contact surfaces of two liquids.

Where acidulated water is in contact with mercury, each liquid possesses a definite surface tension, and each a definite shape of surface. The two liquids, however, do not actually touch, there being a small interval or space between them. This space acts as a minute accumulator. But the liquid and water, being different substances in contact, possess different potentials. Any cause which alters the shape of these contact surfaces, and consequently the extent of the spaces between them, necessarily alters the capacity of the condenser, and consequently the difference of potential. Therefore the mere shaking of the tube, or heating it, will produce electric currents from the resulting differences of potential. Conversely, an electric current sent across the contact-surfaces will produce motion as a result of a change in the value of the surface tension. An electro-capillary telephone has been constructed on the former principle, and an electrometer on the latter. (See *Electrometer, Capillary*.)

Phenomena, Porret — —An increase in the diameter of a nerve fibre in the neighborhood of the positive pole when traversed by a voltaic current.

When a voltaic current passes through fresh living substance the contents of the muscular fibre exhibit a streaming movement in the direction the current is flowing, viz., from the positive to the

negative. This causes the fibre to swell up or increase in diameter at the negative electrode.

Pherope.—A name sometimes applied to a telephote. (See *Telephote*.)

Phial, Leyden — — A name sometimes applied to a Leyden jar. (See *Jar, Leyden*.)

Philosopher's Egg.—(See *Egg, Philosopher's*.)

Phonautograph.—An apparatus for the automatic production of a visible tracing of the vibrations produced by any sound.

Phonautographic apparatus consists essentially of devices by which the sound waves are caused to impart their to-and-fro movements to a diaphragm, at the centre of which a pencil or tracing point is attached. The record is received on a sheet of paper, or wax, or on a smoked glass or other suitable surface.

Leon Scott's Phonautograph, which is among the forms best known, consists of a hollow conical

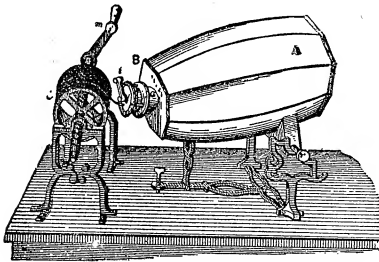

Fig. 421. Scott's Phonautograph.

vessel A, Fig. 421, with a diaphragm of parchment stretched tightly like a drumhead over its smaller aperture B. A tracing point attached to the centre of the diaphragm, traces a sinuous line on the surface of a soot-covered cylinder C, that is uniformly rotated under the tracing point. As the cylinder is advanced a short distance with every rotation, a sinuous spiral line is traced on the surface.

Phone.—A term frequently used for telephote.

Phonic Wheel.—(See *Wheel, Phonic*.)

Phonogram.—A record produced by the phonograph. (See *Phonograph*.)

Phonograph.—An apparatus for the reproduction of articulate speech, or of sounds

of any character, at any indefinite time after their occurrence, and for any number of times.

In Edison's phonograph the voice of the speaker, received by an elastic diaphragm of thin sheet iron or other similar material, is caused to indent a sheet of tin-foil placed on the surface of a cylinder C, Fig. 422, that is maintained at a uniform rate of rotation by the crank at W. In

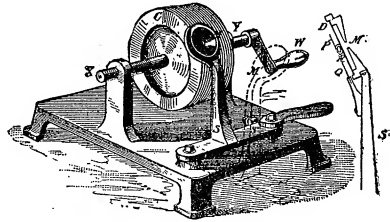

Fig. 422.

the form shown in Fig. 422, the motion is by hand. In a later improved form the cylinder is driven by means of an electric motor or by clockwork.

In order to reproduce the speech or other sounds the *phonogram record* is placed on the surface of a cylinder similar to that on which it was received (or is kept on the same surface), and the tracing point, placed at the beginning of the record and being maintained against it by gentle pressure, is caused, by the rotation of cylinder, to follow the indentations of the phonogram record. As the point is thus moved up and down the hills and hollows of the record surface,

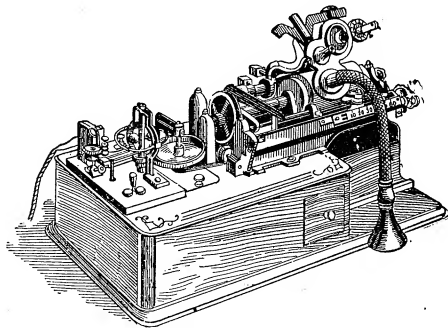

Fig. 423. Edison's Improved Phonograph.

the diaphragm, to which it is attached, is given to-and-fro motions that exactly correspond to the to-and-fro motions it had when impressed originally by the sounds it recorded on the phonogram record. A person listening at this dia-

phragm will therefore hear an exact reproduction of the sounds originally uttered.

In this manner the voices of relatives, distinguished singers or statesmen can be preserved for future generations.

In Edison's improved phonograph the record surface consists of a cylinder of hardened wax. The rotary motion of the cylinder is obtained by means of an electric motor. Two diaphragms are used, one for recording, and one for reproducing the sound waves. As shown in Fig. 423, the recording diaphragm is in position against the cylinder. The recording diaphragm is made of malleable glass. The reproducing diaphragm is formed of bolting silk covered with a thin layer of shellac.

In the *Graphophone* of Bell and Tainter the point attached to the diaphragm is caused to cut

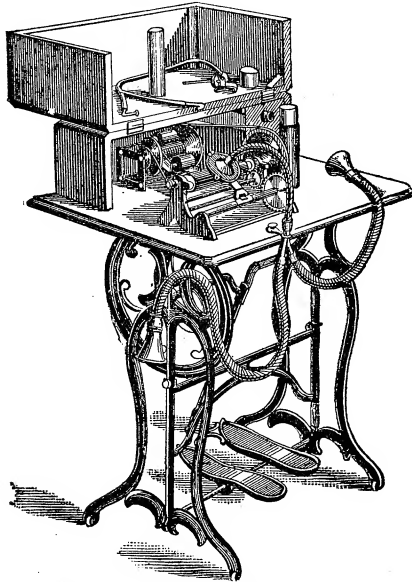

Fig. 424. Bell and Tainter's Graphophone.

or engrave a cylinder of hardened wax. Two separate diaphragms are employed, one for speaking, and the other for hearing.

The recording surface is made of a mixture of beeswax and paraffine. A uniformity of rotation of the cylinder is obtained by means of a motor provided with a suitable governor. An ordinary conversation of some five minutes, it is claimed, can be recorded on the surface of a cylinder 6 inches long and $1\frac{1}{4}$ inch in diameter.

In the *Gramophone* of Berliner, a circular plate of metal, covered with a film of finely divided oil

or grease, receives the record in a sinuous, spiral line. This record is subsequently etched into the metal by any suitable means, or is photographicly reproduced on another sheet of metal.

Glass covered with a deposit of soot is sometimes employed for the latter process. The apparatus is shown in Fig. 425, as arranged for the reproduction of speech.

In Mr. Berliner's apparatus, the record surface is impressed by a point attached to the transmitting diaphragm, in a direction parallel to the record surface, and not, as in the instrument of Mr. Edison, in a direction at right angles to the same. This method would appear to be the best calculated for a more exact reproduction of articulate speech, since it permits comparatively loud speaking or singing, without interfering

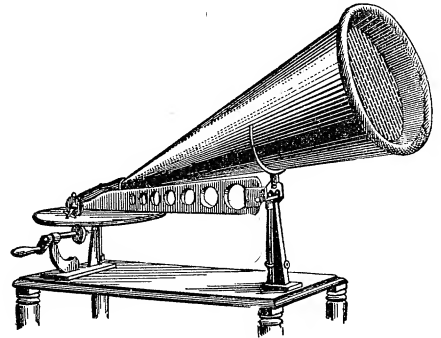

Fig. 425. Berliner's Gramophone.

with the quality of the reproduced sounds. Since the resistance to indentation, or vertical cutting, increases more rapidly than the increase in the amplitude of vibration of the cutting point, it follows that the louder the sounds recorded by the phonograph or graphophone, the less complete would be the quality of the reproduced sounds, or the less the probability of the peculiarities of the speaker's voice being recognized. In order to avoid this, the speaker in the phonograph and the graphophone speaks in an ordinary conversational tone only. (See *Vibration or Wave, Amplitude of*)

For purposes of dictation, and, indeed, most commercial purposes, this is rather an advantage than otherwise.

Phonograph Record.—(See *Record, Phonograph.*)

Phonoplex.—Literally sound folds.

A system of telegraphy. (See *Telegraphy, Phonoplex.*)

Phonoplex Telegraphy. — (See *Telegraphy, Phonoplex.*)

Phonopore.—A modified form of harmonic telegraph.

Phonozenograph.—An instrument devised by De Feltre to indicate the direction of a distant sound.

A Deprez-D'Arsonval galvanometer, a Wheatstone's bridge, and a microphone of peculiar construction, are placed in the circuit of a voltaic battery and a receiving telephone. The observer determines the direction of the distant sound by means of the sounds heard under different conditions in the telephone.

Phosphoresce.—To emit phosphorescent light.

Phosphorescence.—The power of emitting light, or becoming luminous by simple exposure to light.

Bodies that possess the property of phosphorescence, when exposed to a bright light acquire the power, when subsequently carried into the dark, of continuing to emit light, for periods varying from a few seconds to several hours. The diamond, barium and calcium sulphides, dry paper, silk, sugar, and compounds of uranium, are examples of phosphorescent substances.

The effects of phosphorescence appear to be due, in some cases, to sympathetic vibrations set up in the molecules of the phosphorescent body by the exciting light. (See *Vibrations, Sympathetic.*)

In other cases, however, that are not exactly understood, the wave length of the emitted light is more rapid than that of the exciting light.

The fire-fly, the glow-worm, and decaying animal or vegetable matter, exhibit a species of *phosphorescence* that appears to be due to the actual oxidation or gradual burning of a peculiar, specific, chemical substance.

Phosphorescence may therefore be divided into two classes, viz.:

(1.) *Physical phosphorescence*, or that produced by the actual impact of light, and,

(2.) *Chemical phosphorescence*, or that caused by actual chemical combination or combustion of a specific substance. This is sometimes called spontaneous phosphorescence.

Physical phosphorescence may be produced in a variety of ways, viz.:

(1.) By an Elevation of Temperature:

A variety of fluorspar, called chlorophane, shines with a beautiful greenish blue light when heated to less than a red heat. Here the non-luminous rays are apparently transformed into luminous rays.

A phosphorescent substance like fluorspar eventually loses its ability to phosphoresce. It regains it, however, on exposure to the light, *i. e.*, if such an exhausted body be exposed to sunlight it again phosphoresces on exposure to non-luminous heat. The light emitted, during phosphorescence by heat, is, probably, wholly due to potential energy acquired during exposure to the light. (See *Luminescence.*) The phosphorescence by heat exhibited by fluorspar is sometimes called *fluorescence*. It is preferable, however, to call the phenomena phosphorescence. (See *Fluorescence.*)

(2.) By Mechanical Effects:

The flashes of light emitted during the attrition or friction of some bodies, when not traceable directly to electricity, are, most probably, to be ascribed to phosphorescence.

(3.) By Molecular Bombardment.

The molecular bombardment due to the molecules of residual gas shot off from the negative electrode of an exhausted receiver through which an electric discharge is passing, produces many brilliant effects of phosphorescence.

(4.) By Electricity.

An electric spark produces phosphorescence in such substances as canary glass, solution of sulphate of quinine, etc., etc.

(5.) Exposure to Sunlight, or, in fact, to any light.

The different rays of the sun are not equally able to excite phosphorescence. As a rule the violet or ultra violet rays excite the greatest phosphorescence. The light excited is often, though not always, of a greater wave length than the exciting light.

Phosphorescent paints for rendering the position of a push button, electric call, match safe, gas pendant or some other similar object visible at night, consist essentially of sulphides of calcium or barium, or of mixtures of the same.

Phosphorescence, Chemical — — A variety of phosphorescence, in which the emitted light is produced by the actual combustion

of a specific chemical substance by the oxygen of the air.

Chemical phosphorescence is seen in the fire-fly and the glow-worm. (See *Phosphorescence*.)

Phosphorescence, Electric — — Phosphorescence caused in a substance by the passage of an electric discharge.

The phosphorescent material is placed in an exhausted glass tube, as shown in Fig. 426, and submitted to the action of a series of discharges, as from a Ruhmkorff coil, or Holtz machine. The violet-blue light of such discharge is very efficient in producing phosphorescence. Phosphorescence is thus effected by subjecting the phosphorescent material to the molecular bombardment which is produced by such discharges in a high vacuum. (See *Bombardment, Molecular*.)

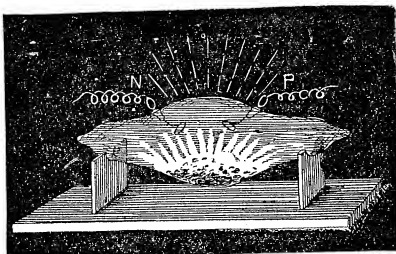

Fig. 426. *Electric Phosphorescence.*

Phosphorescence, Physical — — Phosphorescence produced in matter by the actual impact of light waves resulting in a vibratory motion of the molecules of sufficient rapidity to cause them to emit light.

Physical phosphorescence is distinguished from chemical phosphorescence in that in the former the energy required to produce molecular vibrations is imparted by the light to which the phosphorescent body is exposed, while in chemical phosphorescence the energy producing the light is derived from the chemical potential energy of the specific substance burned. (See *Phosphorescence*.)

Phosphorescent.—Possessing the properties or qualities of phosphorescence.

Phosphorescing.—Emitting phosphorescent light. (See *Phosphorescence*.)

Phosphorescope.—An apparatus for measuring the phosphorescent power of any substance. (See *Phosphorescence*.)

Phosphorus, Electric Smelting of — — An electric process for the direct production of phosphorus.

In the electric smelting of phosphorus, the crude material, consisting of a mixture of bones or animal phosphates and carbon, is fed into a space between two electrodes connected to the poles of a source of powerful alternating currents. The apparatus is similar in general to the Cowles furnace for the reduction of aluminium. The heat produced by the alternating currents decomposes the phosphates, and the volatilized phosphorus is condensed in suitable chambers.

Photochronograph.—An electric instrument for automatically recording the transit of a star across the meridian.

In a small camera connected with the eye-piece of the transit instrument is placed a sensitized plate.

A sidereal clock has an electric attachment to its pendulum, so made that a shutter alternately exposes and conceals the photographic plate, and thus permits the image of a star to be formed on the plate at intervals during its passage across the field of the telescope. An image of the spider lines is afterwards fixed on the plate by the light of a lamp, held for a few moments before the object glass of a telescope. A shutter is provided, by means of which this light is prevented from falling on the trail of the star across the field of the glass. In this manner the time of passage of the star across the meridian is automatically recorded on the photographic plate.

The photochronograph is also adapted for similarly automatically recording the transit or passage of any heavenly body across any imaginary line in the heavens.

Photo-Electric Cell.—(See *Cell, Photo-Electric*.)

Photo-Electricity.—(See *Electricity, Photo*.)

Photo-Electromotive Force.—(See *Force, Electromotive, Photo*.)

Photometer.—An apparatus for measuring the intensity of the light emitted by any luminous source.

There are various methods for measuring the intensity of a beam of light passing through any given space, or emitted from any luminous

source; these methods are embraced in the use of the following apparatus:

(1.) *Calorimetric Photometer*, in which the light to be measured is absorbed by the face of a thermo-electric pile, and the electric current thereby produced is carefully measured. Since *obscure radiation* or heat will also thus produce an electric current, it is necessary first to absorb all the heat by passing the beam of light through an alum cell.

(2.) *Actinic, or Chemical Photometers*, in which the intensity of the light is estimated by a comparison of the depth of coloration produced on a fillet of photographic paper under similar conditions of exposure to a standard light, and the light to be measured.

The combination of pure hydrogen and chlorine, or the decomposition of pure mercurous chloride, have been employed for the purpose of determining the intensities of two lights by measuring the amount of chemical action effected.

(3.) *Shadow Photometers*, in which a shadow produced by the light to be measured is compared with a shadow produced by a *standard candle*. (See *Candle, Standard*.)

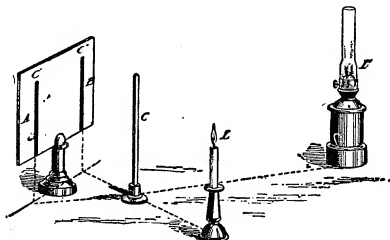

Fig. 427. *The Shadow Photometer.*

Rumford's photometer, shown in Fig. 427, is an example of this form of instrument. The standard candle, shown at L, casts a shadow C", of an opaque rod C, on the screen at B.

The light to be measured L', is moved away from the screen until its shadow C', on the screen at A, is judged by the eye to be of the same depth. The distance between the screen and the lights is then measured in straight lines. *The relative intensities of the two lights are then proportional to the squares of their distances.* If, for example, the candle be at 10 inches from the screen, and the lamp at 40 inches, then the intensities are as $10^2 : 40^2$ or as 100 : 1,600, or the lamp is a 16 candle-power lamp.

This photometer is based on the fact that the shadow of each source is illumined by the light of the other source.

These results are more accurate if the two shadows are adjoining or nearly adjoining.

(4.) *Translucent-Disc Photometers*.—The light to be measured and a standard candle are placed on opposite sides of a sheet of paper the centre of which contains a grease spot. The standard candle is kept at a fixed distance from the paper and both it and the paper are moved towards or from the light to be measured until both sides of the paper are adjudged to be equally illumined.

In Bunsen's photometer a vertical sheet of paper with a grease spot at its centre, is exposed to the illumination of a standard candle on one side, and the light to be measured on the other.

The sheet of paper is placed inside a dark box provided with two plane mirrors placed at such an angle to the paper that an observer can readily see both sides of the paper at the same time.

This box can be slid along a graduated, horizontal scale towards, or from, the light to be measured, and carries with it the standard candle mounted on it at a constant distance of 10 inches. If the box is too near the light to be measured, the grease spot appears brighter on the side of the sheet of paper nearest the candle. If too near the candle, it appears brighter on the side of the sheet of paper nearest the light to be measured. The position in which the spot appears equally bright on both sides, is the position in which both sides of the paper are equally illumined, and the relative intensities of the two lights are then directly as the squares of their distances from the sheet of paper.

Shadow, and translucent-disc photometers being dependent on equal illumination, are reliable only when the color of the lights compared is the same. For the determination of the photometric intensity of very bright lights, the standard candle is replaced by a carcel lamp, a standard gas jet, or by the light emitted by a given mass of platinum, heated to incandescence by a given current of electricity. (See *Lamp, Carcel. Gas-Jet, Carcel Standard, Light, Platinum Standard*.)

Preece's photometer belongs to the class of translucent-disc photometers. A tiny incandescent lamp is placed in a box, the top of which has a white paper screen on which is a grease spot. The box is placed in the street where the intensity of illumination is to be measured, and the inten-

sity of the light of the incandescent lamp is varied until the grease spot disappears. The current of electricity then passing through the incandescent lamp acts as the measure of the illumination.

In the case of the shadow photometer, or of Bunsen's photometer, if the intensity of illumination is the same, the relative intensities of the two lights may be determined as follows:

Calling I , and i , respectively the relative intensities of the standard light, and the light to be measured, and D , and d , their respective distances from the screen, then

$$I : i :: D^2 : d^2, \text{ or } I \times d^2 = i \times D^2;$$

$$\text{that is, } i = I \left(\frac{d^2}{D^2} \right).$$

Or, the intensity of the light to be measured is $\left(\frac{d^2}{D^2} \right)$ times the intensity of the standard light.

If, for example, D and d , represent 10 and 100 inches, respectively, the intensity of i , is 100 times the intensity I , the standard light.

(5.) *Dispersion Photometers.* A class of photometers in which, in order to more readily compare or measure a very bright or intense light, like that of an arc lamp, the intensity of the light is decreased by dispersion a readily measurable amount.

Ayrton & Perry's Dispersion Photometer.—A photometer in which, in order to bring an intensely bright light, like an electric arc light, to

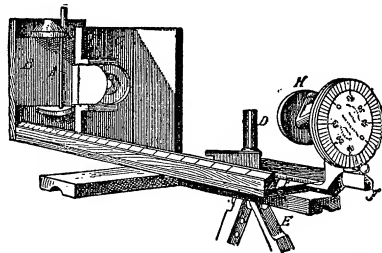

Fig. 428. Ayrton & Perry's Dispersion Photometer.

such an intensity as will permit it to be readily compared with a standard candle, its intensity is weakened by its passage through a diverging (concave) lens.

Ayrton & Perry's dispersion photometer is shown in two different positions, Figs. 428 and 429. The apparatus is supported on a tripod stand E , arranged so as to obtain exact leveling.

A plane mirror H , movable around a pin placed directly under its centre, can be rotated and thus reflect the light after its passage through the diverging lens, while still maintaining its distance from the electric light.

The horizontal axis of this mirror is inclined 45 degrees to its reflecting surface in order to avoid errors arising from varying absorption at different angles of reflection.

The inclination of the beam to the horizontal is indicated by means of an index attached to the mirror and moving over the graduated circle G .

A black rod A , casts its shadow on a screen of white blotting paper B . A standard candle, placed in the holder D , casts its shadow alongside the shadow cast by the electric light. The lens is now displaced until the shadow of the electric light is of the same intensity as that of the candle, when viewed successively through sheets of red and green glass.

A graduated scale serves to mark the distances of the candle and the lens, respectively, from the screen, from which data the intensity of the electric light may be calculated.

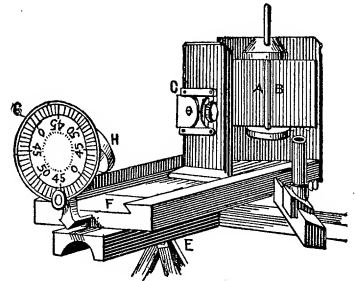

Fig. 429. Ayrton and Perry's Dispersion Photometer.

(6.) *Selenium Photometers.*—Instruments in which the relative intensities of two lights are determined by the variations produced in a selenium resistance.

In Siemens' Selenium photometer a selenium cell is employed in connection with an electric circuit for determining the intensity of light.

The tube $A B$, Fig. 430, is furnished at A , with a diaphragm, and at B , with a selenium plate, connected by wires $G G$, with the circuit of a battery and a galvanometer.

A graduated scale $L M$, bears the standard candle N . The tube $A B$, is capable of rotation on the vertical axis F . A reflecting mirror galvanometer is used in connection with the selenium photometer. The light to be measured is placed

at right angles to the scale L M, and the tube A B, directed towards it, and the galvanometer deflection compared with the deflection obtained when turned towards the standard candle.

(7.) *Gas-Jet Photometers.*—Instruments in which the candle-power of a gas-jet is determined by measuring the height at which the jet burns when under unit conditions of volume and pressure of gas consumed.

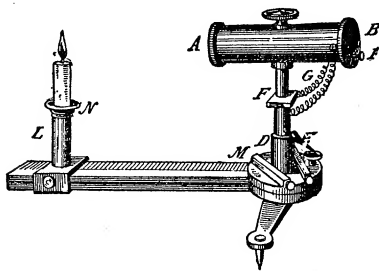

Fig. 430. Siemens' Selenium Photometer.

In determining the candle-power of an intense light like the electric arc light, a large gaslight is used instead of a standard candle, and the photometric power of this gaslight is carefully determined by comparison with a gas-jet photometer. (See *Jet, Gas, Carcel Standard.*)

Photometer, Actinic — —A photometer in which the intensity of any light is measured by the amount of chemical decomposition it effects. (See *Photometer.*)

In some actinic photometers the intensity of the light to be measured is determined by the comparison of the depth of coloration of a sensitized film under similar conditions of exposure to a standard light and the light to be measured.

Photometer, Calorimetric — —A photometer in which the light to be measured is absorbed by the face of a thermo-electric pile, and the intensity of the light estimated from the strength of the electric current thereby produced.

In order to avoid the error arising from the current produced from the absorption of the obscure radiation from the light, all the heat is first absorbed by passing the light through an alum cell. (See *Photometer.*)

Photometer, Chemical — —A photometer in which the intensity of the light to be

measured is determined from the amount of chemical action effected in a given time.

Photometer, Dispersion — —A photometer in which the light to be measured is decreased in intensity a known amount so as to more readily permit it to be compared with a standard light of much smaller intensity. (See *Photometer.*)

Photometer, Electric — —An electrical instrument for measuring the intensity of illumination.

A form of electric photometer invented by C. R. Richards depends for its indications on the variations that occur in the resistance of a wire on change of temperature. An iron wire, whose change of temperature is utilized for measuring the intensity of any light to whose radiations it is opposed, is covered by a deposit of lampblack. On exposure to the light whose intensity is to be measured, the light is absorbed by the lampblack and an increase in temperature occurs.

In order to get rid of the heat rays that are associated with the light rays, the rays before falling on the soot-covered wire are caused to pass through a solution of alum; the intensity of the light is then calculated by reference to the change in the resistance of the soot-covered wire, which is made one of the arms of a Wheatstone bridge.

Photometer, Gas-Jet — —A photometer in which the candle-power of a gas-jet is estimated from a measurement of the height at which the jet burns under unit conditions of volume and pressure. (See *Photometer.*)

Photometer, Jet — —An apparatus for determining the candle power of a luminous source by means of the height of a jet of the gas, whose candle-power is being determined, when burning under constant conditions as to pressure, etc. (See *Jet, Gas, Carcel Standard.*)

Photometer, Selenium — —A photometer in which the intensity of a light is estimated by the comparison of the changes in the resistance of a selenium resistance successively exposed under similar conditions to this light and to a standard light. (See *Photometer.*)

Photometer, Shadow — —A photometer in which the intensity of the light to be

measured is estimated by a comparison of the distances at which it and a standard light produce a shadow of the same intensity. (See *Photometer*.)

Photometer, Translucent Disc — —A photometer in which the light to be measured is placed on one side of a partly translucent and partly opaque disc, and a standard candle is placed on the opposite side, and the intensity of the light estimated by the distances of the light from the disc when an equal illumination of all parts of the disc is obtained. (See *Photometer*.)

When the illumination of the opposite sides of such a disc is equal, the relative positions of the transparent and opaque portions of the disc are indistinguishable.

Photometer, Varley's — —A form of photometer in which the intensity of the light to be measured is determined from the relative openings of two concentric circular diaphragms placed in two rotating discs, and through which the standard light and the light to be measured respectively pass.

The general arrangement of Varley's photometer is shown in Fig. 431. The concentric cir-

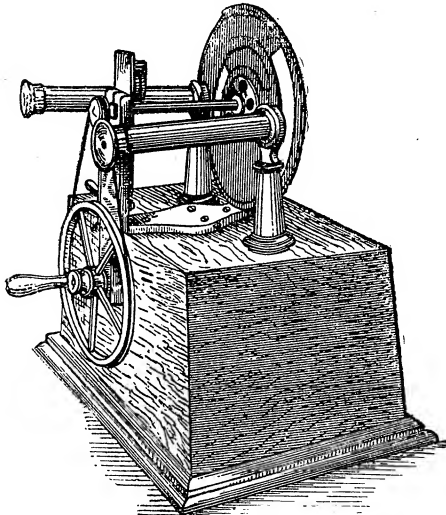

Fig. 431. Varley's Photometer.

cular apertures extend circumferentially 180 degrees, and are reversed so that when one half

ring is fully open, the other is completely closed; or, if one ring, say the outer, is opened 160 degrees, the inner is opened 20 degrees. The quantity of light then which passes through the outer ring from the light to be measured is eight times that passed through the inner ring. The circle is divided into 2,000 parts, instead of into 360 degrees, and, by means of a vernier, these parts are further divided into 10 parts, permitting a reading of the 20,000 divisions.

Two collimeters placed in front of the disc, project a disc with a black centre, and a luminous spot respectively. The discs are regulated until the light projected on the screen produces a uniform disc. This is readily ascertained, since if one or the other predominate, a disc with gray spot, or a gray marginal ring with a bright spot, will appear.

The general appearance of the circular diaphragm, corresponding to different relative positions of the two discs, is shown in Fig. 432.



Fig. 432. Circular Diaphragm of Varley's Photometer.

Photometric.—Of or pertaining to the photometer. (See *Photometer*.)

Photometrically.—In a photometric manner.

Photophone.—An instrument invented by Bell for the telephonic transmission of articulate speech along a ray of light instead of along a conducting wire.

A beam of light, reflected from a diaphragm against which the speaker's voice is directed, is caused to fall on a selenium resistance inserted in the circuit of a voltaic battery, and a telephone. The changes thus effected in the resistance of the circuit by the varying amounts of light reflected on the selenium resistance from the diaphragm, while moving to-and-fro under the influence of the speaker's voice, produce in the receiving telephone a series of to-and-fro movements similar to those impressed on the transmitting diaphragm. One listening at the telephone can hear whatever has been spoken in the neighborhood of the transmitting diaphragm. Telephonic communication can, therefore, by such means be carried on along a

ray or beam of light, theoretically through any distance. (See *Resistance, Selenium.*)

A block of vulcanite or of certain other substances may be used as the receiver, since it has been discovered that a rapid succession of flashes of light produces an audible sound in small masses of these substances.

The term *sonorescence* has been proposed for the property possessed by such substances of emitting sounds when subjected to such intermittent flashes of light. (See *Sonorescence.*)

Photophore, Trouve's — —An apparatus in which the light of a small incandescent electric lamp is employed for purposes of medical exploration.

A small incandescent lamp is placed in a tube containing a concave mirror and a converging lens.

Photo-Telegraphy.—The electric production of pictures, writing, charts or diagrams at a distance.

Photo-Telegraphy is sometimes called telephotography; it is a species of fac-simile telegraphy. (See *Telegraphy, Fac-Simile, Telephotography.*)

Photo-Voltaic Effect.—(See *Effect, Photo-Voltaic.*)

Physical Change.—(See *Change, Physical.*)

Physical Phosphorescence.—(See *Phosphorescence, Physical.*)

Physiological.—Pertaining to physiology.

Physiological Rheoscope.—(See *Rheoscope, Physiological.*)

Physiologically.—In a physiological manner.

Physiology, Electro — —The study of electric phenomena of living animals and plants.

Living animals and plants present electric phenomena, due to the electricity naturally produced by them. It is the province of electrophysiology to ascertain the causes and effects of these phenomena.

Piano, Electric — —A piano in which the strings are struck by hammers actuated by means of electro-magnets, instead of by the usual mechanical action of levers.

An electric piano-action is mainly useful in permitting the instrument to be played at any distance from the key-board. It is also of value from the ease it affords in recording the pieces played.

It fails, however, to properly preserve the various modulations of force so requisite for brilliant instrumentation.

Pickle.—An acid solution in which metallic objects are dipped before being galvanized, or electroplated, in order to thoroughly cleanse their surfaces.

The pickle used for the preparation of iron for galvanization is a weak solution of sulphuric acid in water. Various acids, or acid liquids, are employed for insuring the thorough cleansing of metallic surfaces so necessary in order to ensure an even, uniform, adherent coating of metal by the process of electroplating. (See *Plating, Electro.*)

Piece, Magnetic Proof — —A paramagnetic rod, ellipsoid or sphere employed for ascertaining the distribution of magnetism over a magnet by the force required to detach the same. (See *Paramagnetic.*)

Prof. S. P. Thompson points out the fact that the presence of the proof-piece so alters the distribution of magnetism on the magnet to be measured as to render this method unreliable. He also shows that the force required for detachment depends on the magnetic permeability of the proof-piece, as well as on its shape and its position in the magnetic circuit.

Pieces, Mouth — —Openings into air chambers, generally circular in shape, placed over the diaphragms of telephones, phonographs, gramophones or graphophones to permit the ready application of the mouth in speaking, so as to set the diaphragm into vibration.

The mouth-piece may be also utilized by the ear of an observer listening so as to be affected by its vibrations.

Pieces, Pole, of Dynamo-Electric Machine — —Masses of iron connected with the poles of the field magnet frames of dynamo-electric machines, and shaped to conform to the outline or contour of the armature.

The pole pieces are made in a variety of forms, but in all cases are so shaped as to conform to the outline of the space in which the armature rotates.

The pole pieces are brought as near as possible to the armature, so as to increase the intensity of the magnetic induction. The intervening air space should be as thin as possible, but of as large an area as convenient.

The opposite pole pieces should not have their extensions brought too near together, as this will permit of serious loss through *magnetic leakage*. The distance between them should be as many times the depth of the armature windings as possible. (See *Leakage, Magnetic*.)

Rounded edges are preferable to sharp edges for the same reason.

Pile, Dry — —A voltaic pile or battery consisting of numerous cells, the voltaic couple in each of which consists of sheets of paper covered with zinc-foil on one side and black oxide of manganese on the other.

Various modifications of the above form have been made.

The term dry-pile is a misnomer, since all such piles contain substances moistened by liquid electrolytes.

Pile, Muscular, Matteucci's — —A voltaic battery or pile, the elements of which are formed of longitudinal and transverse sections of muscle alternately connected.

Matteucci's experiments appear to show that the lower the animal is in the scale of creation, the stronger is the current produced, and the longer its duration. Du Bois-Reymond has shown that the muscular current is not due to contact, but to the differences of electric potential naturally possessed by the muscles themselves.

The nerves also possess the power of producing differences of electromotive force, and hence currents. (See *Electrotonus*.)

Pile, Thermo, Differential — —A thermopile in which the two opposite faces are exposed to the action of two nearly equal sources of heat in order to determine accurately the differences in the thermal intensities of such sources of heat.

Pile, Thermo-Electric — —A number of separate thermo-electric couples, united in

series, so as to form a single thermo-electric source. (See *Couple, Thermo-Electric*.)

A thermo-electric pile is sometimes called a thermo-electric battery.

Fig. 433 shows Nobili's thermopile, in which a number of bismuth-antimony thermo-electric couples connected in a continuous series, as shown partly in Fig. 434, are insulated from one another, except at their junctions, and packed in a metallic box, supported as shown in Fig. 433.

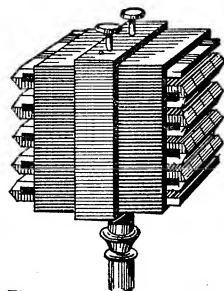

Fig. 433. Thermo-Electric Pile.

The free terminals of the series are connected to binding posts. Differences of temperature between the two faces of the pile, where the junctions are exposed, result in a difference of potential equal to the sum of the differences of potential of all the thermo-electric couples.

A careful inspection will show that the junctions are formed successively at *opposite* faces of the pile, so that if the junctions be numbered successively, the *even* junctions will come at one face, and the *odd* junctions at the other. This is necessary in order to permit all the thermo-electric couples to *add* their differences of potential; for, if, as in Fig. 435, a *thermo-electric chain* be formed,

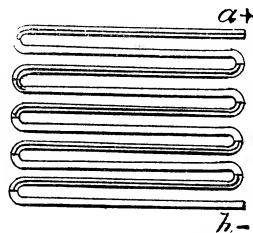

Fig. 434. Series-Connected Thermo-Electric Couples.

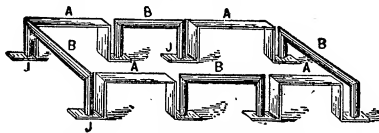

Fig. 435. Thermo-Electric Circuit.

no currents will result from equally heating any two consecutive junctions J, J, of the metals A and B, since the electromotive forces so produced oppose each other.

Thermopiles have been constructed by Clamond, of couples of iron and an alloy of zinc and antimony, of sufficient power to produce a voltaic arc whose illuminating power equaled 40

carcel burners. Many practical difficulties exist which will have to be surmounted, however, before such piles can be employed as commercial electric sources.

Pile, Voltaic — — A battery consisting of a number of voltaic couples connected so as to form a single electric source.

A form similar to Volta's original pile, consisting of alternate discs of copper and zinc, separated from each other by discs of wet cloth, and piled on one another, so as to form a number of separate voltaic couples connected in series, is shown in Fig. 436. The thick plates marked Zn, are of zinc; the copper plates, marked Cu, are much

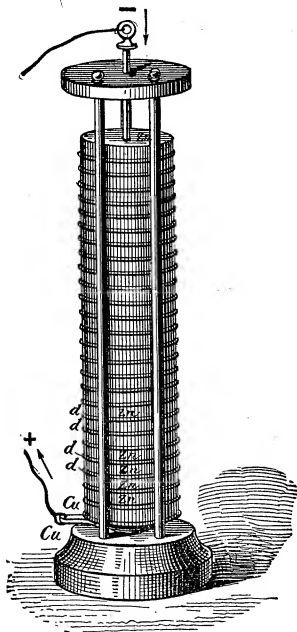

Fig. 436. Voltaic Pile.

thinner. The discs of moistened cloth are shown at d d. One end of such a pile would then be terminated by a plate of copper, and the other by a plate of zinc. The copper end forms the *positive electrode*, and the zinc end the *negative electrode*. (See *Cell, Voltaic*)

Pilot Lamp.—(See *Lamp, Pilot*.)

Pilot Transformer.—(See *Transformer, Pilot*.)

Pilot Wires.—(See *Wires, Pilot*.)

Pin, Insulator — — A bolt by means of which an insulator is attached to the telegraphic support or arm.

The insulator pins or bolts are generally fixed to the insulator by means of screw threads turned on their ends. They are then cemented to the insulators by any suitable moisture-proof cement.

The pin and insulator connected to one another by means of a screw thread are shown in Fig. 437.

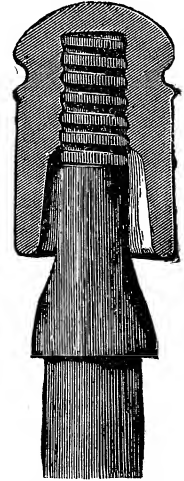

Fig. 437. Insulator Pin.

Pin, Switch — — A metallic pin or plug provided for insertion in a telegraphic switch board.

A form of switch pin is shown in Fig. 438. The metallic end is conical in form, and is provided with two longitudinal slots at right angles to each other in order to insure a light spring connection with the metallic contact plate in which the pin is inserted.

Pith.—A light, cellular material, forming the central portions of most exogenous plants.

An excellent pith, suitable for electrical purposes, is furnished by the dried interior of the elder-berry stick.

Pith Ball.—(See *Balls, Pith*.)

Pith - Ball Electroscope. — (See *Electroscope, Pith-Ball*.)

Pivot Suspension.—(See *Suspension, Pivot*.)

Plain-Pendant Argand Electric Burner. — (See *Burner, Plain-Pendant Electric*.)

Plain-Pendant Electric Burner. — (See *Burner, Plain-Pendant Electric*.)

Plane Angle.—(See *Angle, Plane*.)

Plane, Proof — — A small insulated conductor employed to take test charges from the surfaces of insulated, charged conductors.



Fig. 438. Switch Pin.

The proof-plane is used in connection with some form of electrometer. (See *Balance, Coulomb's Torsion*.)

Plane, Proof, Magnetic — —A small coil of wire placed in the circuit of a delicate galvanometer, and used for the purpose of exploring a magnetic field.

When the coil is suddenly inverted in a magnetic field, if a long-coil galvanometer provided with a heavy needle is used, the number of lines of force which pass through the area of cross-section of the coil will be proportional to the sine of half the angle of the first swing of the needle.

Plant.—A word sometimes used for installation, or for the apparatus required to carry on any manufacturing operation.

An electric plant includes the steam engines or other prime motors, the generating dynamo or dynamos, the lamps and other electro-receptive devices, and the circuits connected therewith.

Plant Electricity. — (See *Electricity, Plant. Plants, Electricity of*.)

Plants, Electricity of — —Electricity produced naturally by plants during their vigorous growth.

DuBois-Reymond and others have shown that plants while in a vigorous vital state are active sources of electricity.

If one of the terminals of a galvanometer be inserted into a fruit near its stem, and the other terminal into the opposite part of the fruit, the galvanometer at once shows the presence of an electric current.

Buff has shown that the roots and interior portions of plants are always negatively charged, while the flowers, fruits and green twigs are positively charged.

Plant tissue or fibre, like the muscular fibre of animals, exhibits in many cases a true contraction on the passage through it of an electric current. This is seen in the *Mimosa sensitiva*, or Sensitive Fern, in the Venus' Fly-Trap, and in several other species of plants.

Pouillet concludes from numerous observations that the free positive electricity of the atmosphere is partly due to the vapors disengaged by growing plants.

The peculiar geographical distribution of thunder storms, however, does not favor this assumption.

(See *Storm, Thunder, Geographical Distribution of*.)

Plastics, Galvano — —A term sometimes employed for electrotyping, that is where the deposits are sufficiently thick to permit of ready separation from the object which forms the mould.

Literally, the cold moulding or shaping of metals by electrotyping. (See *Plating, Electro. Metallurgy, Electro*.)

The word galvano-plastics is sometimes used as synonymous with electrotyping, electro-plating, or electro-metallurgy generally.

Plastics, Hydro — —The art of electrically shaping or depositing metals in the wet by electrotyping. (See *Plastics, Galvano*.)

Plate, Arrester, of Lightning Protector — —That plate of a lightning protector which is directly connected with the circuit to be protected, as distinguished from the plate that is connected with the ground. (See *Arrester, Lightning*.)

Plate Condenser.—(See *Condenser, Plate*.)

Plate, Ground, of Lightning Arrester — —That plate of a comb lightning arrester which is connected to the earth or ground. (See *Arrester, Lightning, Comb*.)

Plate, Negative, of Storage Cell — —That plate of a storage cell which, by the action of the charging current, is converted into or partly covered with a coating of spongy lead.

That plate of a storage battery which is connected with the negative terminal of the charging source, and which is therefore the negative pole of the battery on discharging.

The usage is the reverse of that in the case of the primary battery.

Plate, Negative, of Voltaic Cell — —The electro-negative element of a voltaic couple. (See *Couple, Voltaic*.)

That element of a voltaic couple which is negative in the electrolyte of the cell. (See *Electrolyte*.)

The negative plate of a voltaic cell is the plate not acted on by the electrolyte. In a zinc-carbon

couple in dilute sulphuric acid, the carbon plate is the negative plate. (See *Cell, Voltaic*.)

The negative plate is to be carefully distinguished from the negative pole, which is the terminal connected to the positive plate. The terminal connected to the negative plate is the positive pole. (See *Cell, Voltaic*.)

Plate, Positive, of Storage Battery — — That plate of a storage battery which is converted into, or covered by, a layer of lead peroxide, by the action of the charging current.

That plate of a storage battery which is connected with the positive terminal of the charging source and which is, therefore, the positive pole of the battery on discharging.

It will be noticed that the usage in this respect is the reverse of that in the case of primary batteries, in which the positive plate is positive in the liquid only; the end which projects from the liquid, or the terminal connected with it being negative.

In storage batteries, the positive plate is connected with the positive pole. (See *Battery, Storage. Cell, Voltaic*.)

Plate, Positive, of Voltaic Cell — — The electro-positive element of a voltaic couple. (See *Couple, Voltaic*.)

That element of a voltaic couple which is positive in the electrolyte of the cell. (See *Electrolysis*.)

The positive plate of a voltaic cell is the plate out from which the current flows through the electrolyte.

The zinc plate of a zinc-carbon couple is the positive plate. (See *Cell, Voltaic*.)

The current leaves the cell, however, to flow or pass through the external circuit at the wire or terminal connected with the negative plate. (See *Cell, Voltaic*.)

Plate, Primary, of Condenser — — That plate of a condensing transformer in which the inducing charge is placed in order to induce a charge of different potential in the secondary plate.

Plate, Secondary, of Condenser — — That plate of a condensing transformer in which the induced charge is produced by the induction of a charge on the primary plate.

Plate, Zinc, of Voltaic Cell, Amalgama-

tion of — — Covering the surface of the zinc plate of a voltaic cell with a thin layer of amalgam in order to avoid local action. (See *Action, Local, of Voltaic Cell. Zinc, Amalgamation of*.)

Plates, Arrester — — A term sometimes applied to the two plates of an ordinary comb lightning arrester. (See *Arrester, Lightning, Comb*.)

The plate that is connected to the line to be protected, is more correctly called the arrester plate, and that connected to the ground the ground plate.

Plates of Secondary or Storage Cell, Forming of — — Obtaining a thick coating of lead peroxide on the lead plates of a storage battery, by repeatedly sending the charging current through the cell alternately in opposite directions.

The effect of sending a current between two lead plates immersed in dilute sulphuric acid, is to coat one of the plates with lead peroxide. On the sending of the current in the opposite direction, the other plate is coated with lead peroxide. If now the current is sent in the opposite direction, more peroxide is deposited on one of the plates, and the peroxide at the other plate is converted into spongy lead.

At the end of charging, the battery will form an independent source of current. (See *Cell, Storage*.)

Platform, Pole — — A platform, capable of supporting several men, placed on a terminal pole provided with a cable box, for the purpose of affording a ready means of inspecting and arranging the conductors in the box.

Plating Balance.—(See *Balance, Plating*.)

Plating Bath, Electro — — (See *Bath, Electro-Plating*.)

Plating, Copper — — Electro-plating with copper. (See *Plating, Electro. Bath, Copper*.)

Plating, Electro — — The process of covering any electrically conducting surface with a metal by the aid of the electric current.

By the aid of electro-plating, the baser metals are covered with silver, gold or platinum, or with any other metal, such as nickel or copper.

The process of electro-plating is carried on as follows:

The object to be plated is connected with the negative terminal of a battery and placed in a solution of the metal with which it is to be plated, opposite a plate of that metal connected to the positive terminal of the battery. If, for example, the object is to be plated with copper, it is placed in a solution of copper sulphate or blue vitriol, opposite a plate of copper. By this arrangement the object to be plated forms the kathode of the plating bath, and the plate of copper forms the anode.

On the passage of the current the copper sulphate (Cu SO_4) is decomposed, metallic copper being deposited in an adherent layer on the articles attached to the kathode, and the acid radical (SO_4) appearing at the anode, where it combines with one of the atoms of the copper plate. Since for every molecule of copper sulphate decomposed in the electrolyte, a new molecule of copper sulphate is thus formed, by the gradual solution of the copper anode, the strength of the solution in the bath is maintained as long as any of the copper plate remains at the anode, and the ordinary activity of the cell is not otherwise interfered with.

When any other metals, such as gold, silver or nickel, for example, are to be deposited, suitable solutions of their salts are placed in the bath, and plates of the same metal hung at the anode.

The character and coherence of the metallic coatings thus obtained depend on the nature and strength of the plating bath, and on the density of the current employed. The size and position of the anode, as compared with the size and position of the objects to be plated, must therefore be carefully attended to, as well as the strength of

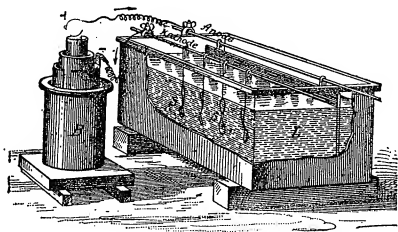

Fig. 439. Electro-Plating

the metallic solution and the current strength passing. (See *Current Density*.)

Fig. 439, shows a bath arranged for silver-plating.

The anode consists of a plate of silver. The

spoons, forks, etc., to be plated are immersed in a suitable silver solution and connected with the kathode.

The electro-plating process when employed for the production of electrotype plates is called electrotyping. Here the object is to obtain a reproduction in metal of any particular form, such as of type or of some natural object. It was called by Jacobi the *galvanoplastic* process. The term *electrotyping* is, however, more generally adopted. (See *Electrotyping, or the Electrotype Process*.)

Plating, Gold — — Electro-plating with gold. (See *Plating, Electro. Bath, Gold*.)

Plating, Nickel — — Electro-plating with nickel. (See *Plating, Electro. Bath, Nickel*.)

Plating, Sectional — — Plating an article with a greater thickness of metal at certain points than at the rest of the surface.

Sectional plating is employed for such objects as spoons, etc., which are, by this method, given a greater thickness of deposit at the under portions of the bowl and handle, where the spoon usually rests, and is, therefore, exposed to the greatest wear.

Sectional plating is effected by means of sectional plating frames. (See *Plating, Electro. Frames, Sectional Plating*.)

Plating, Silver — — Electro-plating with silver. (See *Plating, Electro. Bath, Silver*.)

Platinoid.—An alloy consisting of German silver containing 1 or 2 per cent. of metallic tungsten.

Platinoid is suitable for use in resistance coils on account of the comparatively small influence produced on its electric resistance by changes of temperature.

Its resistance is 60 per cent. higher than that of German silver.

Platinum.—A refractory and not readily oxidizable metal, of a tin-white color.

The co-efficient of expansion of platinum by heat is very nearly that of ordinary glass. Platinum is, therefore, generally employed for the leading-in conductors of an incandescent lamp. These conductors are fused into the glass of the lamp chamber. On the heating of the wires by

the current, the glass expands equally with the wires, and the vacuum in the lamp chamber is not, therefore, injured.

Platinum Alloy.—(See *Alloy, Platinum-Silver*.)

Platinum Black.—Finely divided platinum that possesses, in a marked degree, the power of absorbing or occluding gases.

Platinum black is obtained by the action of potassium hydrate on platinum chloride. Unlike metallic platinum it is of a black color.

Platinum Fuse.—(See *Fuse, Platinum*.)

Platinum-Silver Alloy.—(See *Alloy, Platinum-Silver*.)

Platinum Standard Light.—(See *Light, Platinum Standard*.)

Platometer.—An instrument invented by Sir William Thomson for comparing the capacities of two condensers.

Plow.—The sliding contacts connected to the motor of an electric street car, and placed within the slotted underground conduit, and provided for the purpose of taking off the current from the electric mains placed therein, as the contacts are pushed forward over them by the motion of the car.

Similar contacts, placed in the rear of the motor car and drawn after the train, form what is technically known as the *sled*, or when rolling on overhead wires as *trolleys*. (See *Railroad, Electric*.)

Plow, Electric — —A plow driven by an electric motor placed either on a wagon to which the plow is attached, or by a stationary electro-motor, by the aid of cords or other flexible belts.

One of the first practical applications of the electric transmission of energy was for the operation of a plow, driven electrically, by an electric current generated at some distance, and transmitted to the electric motor by suitable conductors.

Plücker Tube.—(See *Tube, Plücker*.)

Plug.—A piece of metal in the shape of a plug, provided for making or breaking a circuit by placing in, or removing from, a conical opening formed in the ends of two closely approached pieces of metal which are

connected with the circuits to be made or broken.

As the plug is inserted in the opening it bridges over the opening and thus closes the circuit connected with the separate pieces of metals. On removing the plug the circuit is opened or broken.

Plug.—In telegraphy, an inexperienced operator.

Plug, Double — —A plug so constructed that when inserted in a spring-jack it makes two connections, one at its point and one at its shank. (See *Spring-Jack*.)

Plug, Fusible — —A term sometimes applied to a safety fuse. (See *Plug, Safety*.)

Plug, Infinity — —A plug hole in a box of resistance coils, in which the two pieces of brass it connects are not connected by any resistance coil, and which, therefore, leaves, when withdrawn, an open circuit of an infinite resistance.

Plug, Safety — —A wire, bar, plate or strip of readily fusible metal, capable of conducting, without fusing, the current ordinarily employed on the circuit, but which fuses, and thus breaks the circuit, on the passage of an abnormal current. (See *Fuse, Safety*.)

A safety plug is only used on circuits in which the electro-receptive devices are connected with the leads in multiple. In this case the fusing of the safety plug, and the consequent opening of the circuit with which it is connected, does not affect the rest of the circuit. On series-connected circuits a different form of safety device is used. (See *Cut-Out, Automatic, for Series-Connected Electro-Receptive Devices*.)

Plug, Short-Circuiting — —A plug by means of which one part of a circuit is cut out by being short-circuited.

Plug Switch.—(See *Switch, Plug*.)

Plug, Wall — —A plug provided for the insertion of a lamp or other electro-receptive device in a wall socket, and thus connecting it with a lead.

Plugging.—Completing a circuit by means of plugs.

Plugs, Grid — —Plugs of active material that fill the spaces or apertures in the lead grid or plate of a storage battery.

The active material forming the plugs is placed in the spaces in the grid while in the plastic condition. On the subsequent hardening of this material, these grid plugs cannot readily fall out, since the spaces are so shaped that their interior portions are of greater diameter than at the surface of the plates.

Plumbago.—An allotropic modification of carbon.

Plumbago, the material commonly known as *black lead*, is the same as graphite. Powdered plumbago is employed in *electrotyping processes* for rendering non-conducting surfaces electrically conducting. For this purpose powdered plumbago is dusted on the surfaces, which thus acquire the power of receiving a metallic lustre by friction. Stove polishes are formed of mixtures of plumbago and other cheap materials. (See *Graphite*.)

Strictly speaking, the term graphite is properly applied to such varieties of plumbago as are suitable for direct use for writing purposes, as in lead pencils.

Plumbago, Coppered — — Powdered plumbago coated with copper, for use in the metallization of objects to be electro-plated. (See *Metallization*.)

Plumbago, Gilt — — Powdered plumbago whose conducting power for electricity has been increased by coating it with metallic gold.

Gilt plumbago is used for rendering non-conducting surfaces electrically conducting and thus preparing them for electro-plating.

To prepare gilt plumbago, dissolve in 100 parts of sulphuric ether 1 part of chloride of gold, mix in this 60 parts of powdered plumbago, and expose to air and light until all ether has volatilized. Then dry in an oven.

Plumbago, Silvered — — Powdered plumbago coated with metallic silver for use in the metallization of objects to be electro-plated.

Plunge Battery.—(See *Battery, Plunge*.)

Pneumatic Perforator.—(See *Perforator, Pneumatic*.)

Pneumatic Signals, Electro — —(See *Signals, Electro-Pneumatic*.)

Pockets, Armature — —Spaces provided in an armature for the reception of the

armature coils. (See *Coils, Armature, of Dynamo-Electric Machine*.)

Poggendorff's Voltaic Cell.—(See *Cell, Voltaic, Poggendorff's*.)

Point, Carbon — —A term formerly applied to the carbon electrodes used in the production of the voltaic arc.

Point, Indifferent — —A point in the intra-polar regions of a nerve where the anelectrotonic and katelectrotonic regions meet, and where the excitability is therefore unchanged.

This is sometimes called the neutral point.

Point of Lightning Rod.—(See *Rod, Lightning, Points on*.)

Point of Origin.—(See *Origin, Point of*.)

Point, Neutral — —In electro-therapeutics, a term sometimes used instead of indifferent point. (See *Point, Indifferent*.)

Point, Nodal — —The null point in a circuit traversed by electric oscillations. (See *Point, Null*.)

Point, Null — —Such a point on a micrometer circuit, that when joined or connected with the secondary circuit of an induction coil, the sparks in the micrometer circuit are either very greatly decreased or are entirely absent.

The null point on the micrometer circuit is situated symmetrically with respect to the micrometer knobs.

If the induction coil A, Fig. 440, has its secondary circuit connected as shown with the micrometer circuit at the point e, situated at the centre of the micrometer circuit, the point will be a null point, and the effects of sparks at the micrometer knobs, at M, will be greatly decreased. Under the conditions shown in the figure, the electrical oscillations in the micrometer circuit must be regarded as in the condition of stationary waves or vibrations. It would seem, therefore, that definite waves or vibrations are set up in the microm-

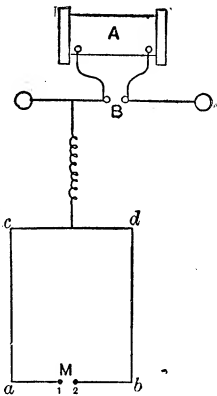

Fig. 440. Null Point.

eter circuit, in the same way as are the vibrations produced in an elastic bar set in vibration by a violin bow, or by a blow from a hammer.

Points, Consequent — —The points or places in an anomalous magnet where the consequent poles are situated. (See *Magnet, Anomalous. Pole, Anomalous.*)

Points, Corresponding — —Points where the lines of electrostatic force surrounding an insulated charged conductor enter the surfaces of neighboring conductors.

Points on the surface of a body placed in an electrostatic field where the lines of electrostatic force enter its surface, and thus produce a charge equal and opposite to that of the surface of the body at the points from which they came.

Corresponding points receive, in accordance with the laws of electrostatic induction, charges equal and opposite to those of the surfaces from which the lines of electrostatic force originate.

Points, Electric Action of — —The effect of points placed on an insulated, charged conductor, in slowly discharging the conductor by electric convection. (See *Convection, Electric.*)

The cause of this action of points is to be attributed to the increased density of a charge on the surface of a conductor at the points and the consequent production of convection streams of air, which thus gradually carry off the charge. (See *Charge, Distribution of.*)

Points, Iso-Electric — —A term sometimes used in electro-therapeutics for points of equal potential.

Points, Neutral, of Dynamo-Electric Machine — —Two points of greatest difference of potential, situated on the commutator cylinder, at the opposite ends of a diameter thereof, at which the collecting brushes must rest in order to carry off the current quietly.

These are called the neutral points because the coils that are short-circuited by the brushes lie in the magnetically neutral points of the armature. (See *Line, Neutral, of Commutator Cylinder.*)

Points, Neutral, of Magnet — —Points approximately midway between the poles of

a magnet. (See *Line, Neutral, of a Magnet. Magnet, Equator of.*)

Points, Neutral, of Thermo-Electric Diagram — —The points on a thermo-electric diagram where the lines representing the thermo-electric powers of any two metals cross one another.

A mean temperature for any two metals in a thermo-electric series, at which, if their two junctions are slightly over and slightly under the mean temperature (the one as much above as the other is below), no effective electromotive force is developed. (See *Diagram, Thermo-Electric. Couple, Thermo-Electric.*)

Points or Rhumbs of Compass.—(See *Compass, Points of.*)

Polar Region.—(See *Region, Polar.*)

Polar Tips.—(See *Tips, Polar.*)

Polarity, Diamagnetic — —A polarity the reverse of ordinary magnetic polarity, the existence of which was assumed by Faraday to explain the phenomena of diamagnetism. (See *Diamagnetism.*)

Faraday assumed that diamagnetic substances, when brought into a magnetic field, acquired *north magnetism* in those parts that were nearest the north pole, instead of *south magnetism*, as with ordinary magnetic substances. The north pole thus obtained would, he thought, explain the apparent repulsion of a slender rod of any diamagnetic material delicately suspended in a strong magnetic field, and cause it to point equatorially, or with the lines of force passing through its least dimensions. This supposition was subsequently abandoned by Faraday. It has recently been revived by Tyndall. (See *Diamagnetism.*)

The action of a diamagnetic body, when placed in a magnetic field, is now generally ascribed to the fact that the atmosphere, by which such body is surrounded, is more powerfully paramagnetic than the diamagnetic substance. The diamagnetic substance comes to rest in an equatorial position, because in that position there is the greatest length of air in the path of the magnetic lines, which has a smaller magnetic resistance than the diamagnetic substance.

Polarity, Magnetic — —The polarity acquired by a magnetizable substance when brought into a magnetic field.

The direction of magnetic polarity, acquired by a substance when brought into a magnetic field, depends on the direction in which the lines of magnetic force pass through it. Where these lines enter the substance a south pole is produced, and where they pass out, a north pole is produced. The *axis of magnetization lies in the direction of the lines of force as they pass through the body*, and the *intensity of magnetization* depends on the number of these lines of force which pass through the body.

The cause of magnetic polarity is not definitely known. Hughes' hypothesis attributes it to a property inherent in all matter. Ampère attributes it to closed electric circuits in the ultimate particles. Whatever its cause, it is invariably manifested by a magnetic field, the lines of force of which are assumed to have the direction already mentioned. (See *Magnetism, Hughes' Theory of Magnetism, Ampère's Theory of Magnetism, Ewing's Theory of.*)

Polarization, Galvanic. — —A term sometimes applied to the polarization of a voltaic cell. (See *Cell, Voltaic, Polarization of.*)

Polarization, Internal, of Moist Bodies — —A polarization exhibited by such moist bodies as the nerves, muscular fibres, the juicy parts of vegetables and animals, or in general by all bodies possessing a firm structure filled with a liquid, on the passage through them of a strong electric current.

Polarization, Magnetic Rotary — —The rotation of the plane of polarization of a beam of plane-polarized light consequent on its passage through a plate of glass subjected to the stress of a magnetic field. (See *Rotation, Magneto-Optic.*)

Polarization of Dielectric.—(See *Dielectric, Polarization of.*)

Polarization of Electrolyte.—(See *Electrolyte, Polarization of.*)

Polarization of Voltaic Cell.—(See *Cell, Voltaic, Polarization of.*)

Polarized Armature.—(See *Armature, Polarized.*)

Polarized Relay.—(See *Relay, Polarized.*)

Polarizing Current.—(See *Current, Polarization.*)

Polarizing Electro-Therapeutic Current. —(See *Current, Electro-Therapeutic Polarizing.*)

Pole, Analogous — —That pole of a pyro-electric substance, like tourmaline, which acquires a positive electrification while the temperature of the crystal is rising. (See *Electricity, Pyro.*)

Pole, Anomalous — —A name sometimes given to those parts or poles in an anomalous magnet which consist of two similar free poles placed together. (See *Magnet, Anomalous.*)

Pole, Antilogous — —That pole of a pyro-electric substance, like tourmaline, which acquires a negative electrification when the temperature of the crystal is rising, and a positive electrification when it is falling. (See *Electricity, Pyro.*)

Pole, Armature — —(See *Armature, Pole.*)

Pole Changer.—A switch or key for changing or reversing the direction of current produced by any electric source, such as a battery.

The *commutator of a Ruhmkorff coil* is a simple form of pole changer. It is, however, usually called a commutator. (See *Coil, Induction.*)

Pole-Changing and Interrupting Electrode Handle.—(See *Electrode-Handle, Pole-Changing and Interrupting.*)

Pole-Changing Switch.—(See *Switch, Pole-Changing.*)

Pole Climbers.—(See *Climbers, Pole.*)

Pole, Consequent — —A magnet pole formed by two free north or two free south poles placed together. (See *Magnet, Anomalous.*)

Pole, Magnetic, Austral — —A name formerly employed in France for the north-seeking pole of a magnet.

That pole of a magnet which points to the earth's geographical north.

It will be observed that the French regarded the magnetism of the earth's Northern Hemisphere

as north, and so named the north-seeking pole of the needle the austral or south pole.

The north-seeking pole of the magnet is sometimes called the boreal or north pole. (See *Pole, Magnetic, Boreal.*)

Pole, Magnetic, Boreal — —A name formerly employed in France for the south-seeking pole of a magnet, as distinguished from the austral or north-seeking pole.

That pole of a magnet which points toward the geographical south.

If the earth's magnetic pole in the Northern Hemisphere be of north magnetism, then the pole of a needle that points to it must be of the opposite polarity, or of south magnetism. In this country we call the end which points to the north the north-seeking pole or marked pole. In France the end which points to the north was formerly called the austral pole. Austral means south pole. (See *Pole, Magnetic, Austral.*)

Pole, Magnetic, False — —A term proposed by Mascart and Joubert to designate the place or places on the earth which apparently act as magnetic poles, in addition to the two true magnetic poles, near the earth's geographical poles.

According to these authorities, the earth possesses two magnetic poles only, viz., a negative pole in the Northern Hemisphere and a positive pole in the Southern Hemisphere. The additional poles are called by them the false magnetic poles.

Pole, Magnetic, Free — —A pole in a piece of iron, or other paramagnetic substance, which acts as if it existed as one magnetic pole only.

A free magnetic pole has in reality no physical existence. The conception, however, is of use in describing certain magnetic phenomena. If the bar of iron be so long as to practically place one pole beyond the sensible action of the other, either pole may be regarded as a free pole.

Pole, Magnetic, Marked — —That pole of a magnetic needle which points approximately to the earth's geographical north. (Obsolete.)

The north-seeking pole of a magnetic needle.

Pole, Magnetic, North — —That pole of a magnetic needle which points approximately to the earth's geographical north.

The north-seeking pole of a magnetic needle.

Pole, Magnetic, North-Seeking — — That pole of a magnetic needle which points approximately towards the earth's geographical north.

Pole, Magnetic, Salient — —A term sometimes applied to the single poles at the extremities of an anomalous magnet, in order to distinguish them from the double or consequent pole formed by the juxtaposition of two similar magnetic poles. (See *Magnet, Anomalous.*)

Pole, Magnetic, South — —That pole of a magnetic needle which points approximately towards the earth's geographical south.

The south-seeking pole of a magnetic needle.

Pole, Magnetic, South-Seeking — — That pole of a magnetic needle which points approximately toward the geographical south.

Pole, Negative — —That pole of an electric source through which the current is assumed to enter or flow back into the source after having passed through the circuit external to the source.

Pole-Pieces of Dynamo-Electric Machine. —(See *Pieces, Pole, of Dynamo-Electric Machine.*)

Pole Platform.—(See *Platform, Pole.*)

Pole, Positive — —That pole of an electric source out of which the electric current is assumed to flow.

Pole Steps.—Short rods or bars shaped so as to be readily inserted in holes near the base of telegraph or electric light poles, so as to serve as steps to enable a lineman to reach the permanently placed steps.

Permanent steps are placed only at some distance from the ground, in order to prevent the ready climbing of the poles by unauthorized persons.

Pole, Telegraphic — —A wooden or iron upright on which telegraphic or other wires are hung.

Wooden poles are generally round.

The *terminal pole*, or the last pole at each end of the line, or where the wires bend at an angle of nearly 90 degrees, is made larger than usual and is often cut square.

The holes for the poles must be dug in the true line of the wires, and not at an angle to such line. As little ground should be disturbed in the digging as possible. *Earth borers*, or modifications of the ordinary ship auger, are generally employed for this purpose. When the pole is placed in position the ground should be *rammed* or *punned* around the pole.

In *setting the pole*, it is generally buried at least 5 feet in the ground. In England the poles are planted to a depth of about one-fifth of their length. In embankments and loose ground, they are planted deeper than in more solid earth. On curves, the poles should be inclined a little so as to lean back against the lateral strain of the wire, since by the time the ground has completely set, the strain of the wire will have pulled them into an erect position.

Care must be taken to so plant the poles on that side of a road or railway that the prevailing winds will blow them off the roadbed, should it overturn them. As to location, the top of steep cuttings is preferable to the slope. In all exposed positions, it is preferable to strengthen the poles by *stays* attached to both sides.

Where the number of wires is unusually large, heavy timber, or in case of its absence, double

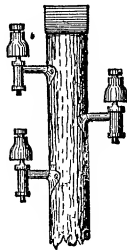

Fig. 441. Telegraphic Brackets.

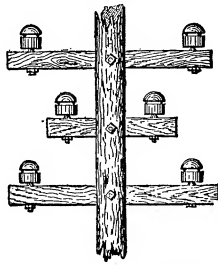

Fig. 442. Telegraphic Arms.

poles suitably braced together, must be employed. In long lines the poles should all be numbered in order to afford ease of reference in case of repair.

When, even with the best *punning*, and other precautions, the pole is judged to be unable to resist the strain on it, *stays* and *struts* are employed. A *stay* is used when it is desired to remove the *pull* or *tension* from the pole; a *strut*, when it is desired to remove the *thrust* or *pressure*.

The *arms* or *brackets*, or the cross-pieces that

support the *insulators*, should all be placed on the same side of the poles. Some common forms of brackets are shown in Fig. 441, and of telegraphic arms in Fig. 442.

Saddle brackets should be placed on alternate sides of the poles. When the strain on an insulator is too great, on account of the wire going off at a sharp angle, a *shackle* is used. This is a special form of insulator which confines the strain to one spot.

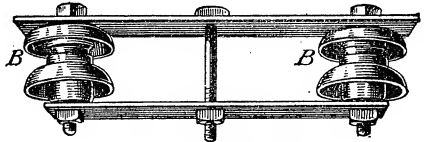

Fig. 443. Double Shackles.

A form of *double shackle* is shown in Fig. 443. The wire passes around the recess at B, between the two insulators.

On curves, or in any situation where there is a probability, in case of the breaking of an insula-

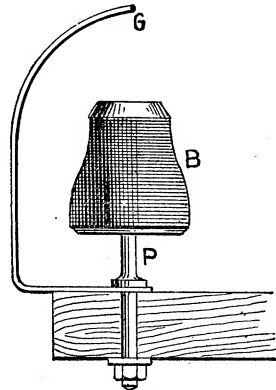

Fig. 444. Hook Guard.

tor, of a wire getting into a dangerous position, *guards* should be employed.

Guards are of two kinds, viz.: *hoop guards* and *hook guards*. A form of *hook guard* is shown in Fig. 444.

When wooden poles are employed various preservative methods are adopted to protect the wood from decay, which is very apt to occur, especially where the pole enters the ground. Some of these forms are as follows, viz.:

(1.) *Charring* and *tarring* the butt end of the pole where it enters the ground, so as to expel the sap and destroy injurious plant or animal germs.

The charred end is then cleansed and dipped in a mixture of tar and slaked lime.

(2.) *Burnetizing*, or the introduction of chloride of zinc into the pores of the wood, by placing the poles in an open tank filled with a solution of this salt.

(3.) *Kyanizing*, or the similar introduction of corrosive sublimate, or mercuric chloride.

(4.) *Boucherizing*, or the injection of a solution of copper sulphate into the pores of the wood.

(5.) *Creosoting*, or the application of creosote to well seasoned poles.

Pole, Telegraphic, Punning of — — Rammng or packing the earth around the base of a telegraph pole for the purpose of more securely fixing it in the ground.

Pole, Telegraphic, Terminal — — —The pole at either end of a telegraphic line.

As the first or last pole in a telegraphic line is not supported on opposite sides by the line wires, it is generally made stouter than the intermediate poles, and greater care is taken to fix it securely in the ground.

Pole, Testing — — —A term sometimes employed in electro-therapeutics for the indifferent pole or electrode. (See *Electrode, Indifferent*.)

Pole, Trolley — — —The pole which supports the trolley bearing and rests on the socket in the trolley base frame in an overhead wire electric railway system.

Pole, Unit, Magnetic — — —A magnetic pole of such a strength that it would act with a unit or dyne of force on another unit pole at a distance of one centimetre.

Poles, Consequent — — —The name given to single magnetic poles formed by two free N. poles or two free S. poles placed together. (See *Magnet, Anomalous*.)

Poles, Idle — — —Poles or electrodes in Crookes' tubes, between which discharges are not taking place.

The idle poles have no connection with the induction coils or other sources from which the electric discharges are obtained. These poles are provided for attaching galvanometer wires, etc., in the study of the Edison effect, or for the study of the

electrical condition of the dark space and other regions of the atmosphere of the tube.

Poles, Magnetic — — —The two points where the lines of magnetic force pass from the iron into the air, and from the air into the iron.

The two points in a magnet where the magnetic force appears to be concentrated.

In reality the magnetic force is most concentrated at the neutral points of a magnet, through which all the lines of force pass.

All magnets possess at least two poles, one positive or north, and the other negative or south.

The lines of magnetic force are assumed to come out of a magnet at its north pole, and to enter it at its south pole.

Poles, Magnetic, of Verticity — — —(See *Verticity, Poles of, Magnetic*.)

Poles of Condenser.—The terminals of a condenser. (See *Condenser*.)

Poles of Magnetic Intensity.—(See *Intensity, Magnetic, Pole of*.)

Polyphase Current.—(See *Current, Multi-Phase*.)

Polyphotal Arc Light Regulators.—(See *Regulator, Polyphotal Arc-Light*.)

Poppun, Electro-Magnetic — — —A magnetizing coil, provided with a tubular space for the insertion of a core, much shorter than the length of the coil, which, when the energizing current is passed through the coil, is thrown violently out from the coil.

The movement and consequent expulsion of the core is due to the action of the lines of magnetic force which complete their circuit through the core.

Porcelain.—A variety of insulating material.

A translucent variety of earthenware.

Porous Cell.—(See *Cell, Porous*.)

Porous Cup.—(See *Cup, Porous*.)

Porous Insulation.—(See *Insulation, Porous*.)

Porous Jar.—(See *Jar, Porous*.)

Porret's Phenomena.—(See *Phenomena, Porret*.)

Portative Power.—(See *Power, Portative*.)

Portelectric.—An electric carrier.

A system of electric transportation by means of the successive attractions of a number of hollow helices of insulated wire on a hollow solenoidal iron car.

The solenoidal car forms the movable core of the helical coils. As it moves through these coils it automatically closes the circuit of an electric current through the coils in advance of it and opens the circuit of the coils in its rear. In this way the solenoidal car advances in a line coincident with the axis of the helical coils, being virtually sucked through them by their magnetic attractions. This system of electric propulsion is unique in systems of electric traction. The motor becomes a mere mass of iron or other paramagnetic material. The system is suitable for the carriage of mail or other comparatively light articles at a high speed.

In an experimental plant at Dorchester, Mass., a track of 2,784 feet in length was laid in the approximate form of an oval. The track was formed by an upper and lower rail of steel, suitably supported by stringers.

The car, which forms the movable core of the solenoidal coils, was of wrought iron, and was cylindrical in shape, with conical ends. It was

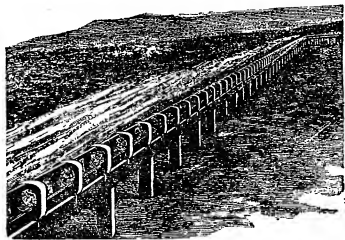

Fig. 445. Portelectric Track.

12 feet in length and 10 inches in diameter, and weighed about 500 pounds. It would carry about 10,000 letters. It had two flanged wheels above and two below.

The solenoidal coils, by the attractive power of which the core was moved, embraced the track and the movable core or carrier. They were fixed along the track at intervals of 6 feet from centre to centre. Each coil was formed of 630 turns of No. 14 copper wire. The upper track rail is divided into sections which form conductors for the driving current. A central wheel was

placed on the top of the carrier and connected the several helices successively with the electric

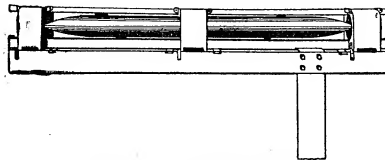

Fig. 446. Portelectric Car.

source as the carrier was drawn forward. A speed of about 34 miles an hour was reached.

A section of the track is shown in Fig. 445, and the shape and general structure of the carrier in Fig. 446.

Portrait, Electric — —A portrait formed on paper by the electric volatilization of gold or other metal.

An electric portrait is obtained by cutting on a thin card a portrait in the form of a stencil. A sheet of gold leaf is then placed on one side of the

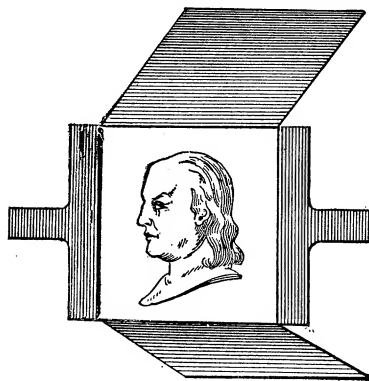

Fig. 447. Electric Portrait.

paper stencil, and a sheet of paper on the other side; sheets of tin-foil are then placed on the outside, as shown in Fig. 447, and the whole firmly pressed together. If, now, a disruptive discharge is passed through from one sheet of tin-foil to the other, the gold leaf is volatilized, and a purplish stain is left on the paper of the outlines of the stenciled card, thus forming an electric portrait.

Position, Energy of — —A term used for stored energy, or potential energy. (See *Energy, Potential*.)

Positive Direction of a Simple-Harmonic Motion.—(See *Motion, Simple-Harmonic, Positive Direction of*.)

Positive Direction of Lines of Magnetic Force.—(See *Force, Magnetic, Lines of, Positive Direction of*.)

Positive Direction of the Electrical Convection of Heat.—(See *Direction, Positive, of Electrical Convection of Heat*.)

Positive Direction Round a Circuit.—(See *Direction, Positive, Round a Circuit*.)

Positive Direction Through a Circuit.—(See *Direction, Positive, Through a Circuit*.)

Positive Electricity.—(See *Electricity, Positive*.)

Positive Electrode.—(See *Electrode, Positive*.)

Positive Feeders.—(See *Feeders, Positive*.)

Positive-Omnibus Bars.—(See *Bars, Positive Omnibus*.)

Positive Phase of Electrotonus.—(See *Electrotonus, Positive Phase of*.)

Positive Plate of Storage Battery.—(See *Plate, Positive, of Storage Battery*.)

Positive Plate of Voltaic Cell.—(See *Plate, Positive, of Voltaic Cell*.)

Positive Pole.—(See *Pole, Positive*.)

Positive Potential.—(See *Potential, Positive*.)

Positive Side of Circuit.—(See *Circuit, Positive Side of*.)

Positively.—In a positive manner.

Positively Excited.—Excited or charged with positive electricity. (See *Electricity, Positive*.)

Post, Binding — —A device for connecting the terminal of an electric source with the terminal of an electro-receptive device, or for connecting different parts of an electric apparatus with one another.

The conducting or circuit wire is either introduced in the opening *a*, or *c'*, Fig. 448, and clamped by the screw *b*, or *b'*, or is placed in the space *d, d*, and kept in place by means of a thumbscrew. Sometimes two openings are provided at *c*, and *c'*, for the purpose of connecting two wires together.

A device for coupling or connecting the ends of two wires to each other. It is then called a coupler. (See *Couple, Voltaic*.)

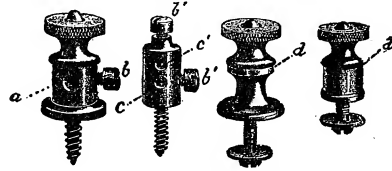

Fig. 448. Binding Posts.

Pot, Porous — —The porous jar or cell of a voltaic cell. (See *Cell, Porous*.)

Potential, Alternating — —A potential, the sign or direction of which is alternately changing from positive to negative.

An alternating potential may be obtained either in the case of an electrostatic field, or in that of a magnetic field.

Potential, Alternating Electrostatic — —The potential of a charge that is undergoing rapid alternations.

Potential, Alternating, Magnetic — —The difference of magnetic potential produced by alternating electric currents.

Potential, Constant — —A potential which remains constant under all conditions.

A machine or other electric source is said to have a constant potential when it is capable, while in operation, of maintaining a constant difference of electric pressure between its two terminals on changes of load. (See *Circuit, Constant-Potential*.)

Potential, Difference of — —A term employed to denote that portion of the electromotive force which exists between any two points in a circuit.

The difference of potential at the poles of any electric source, such as a battery or dynamo, is that portion of the total electromotive force which is available, and is equal to the total electromotive force, less what is lost in the source.

Some difference of opinion exists as to the exact meaning that is attached to the phrase difference of potential.

A positively electrified body is said to have a higher electric potential than the earth, whose potential is taken as zero.

Potential, Difference of, Methods of Measuring — — Methods employed for determining differences of potential.

These methods are as follows:

(1.) *By the Method of Weighing*, that is, by obtaining the *weight* required to overcome the attraction between two oppositely charged plates, or oppositely energized coils; or by measuring the repulsion between similarly charged surfaces, or similarly energized coils.

(2.) *By the Use of Electrometers*, or apparatus designed for measuring differences of potential. (See *Electrometers*.)

(3.) *By the Use of Galvanometers*.

Differences of potential, in the case of currents, may be determined from the quantity of electricity which flows per second through a given circuit, that is, by the number of ampères, just as the pressure of water at any point in the side of a containing vessel can be determined by the quantity of water that flows per second. Difference of potential in the case of currents, therefore, may be measured by any galvanometer which measures the current directly in ampères, provided the resistance of the circuit is known.

Potential, Drop of — — A term sometimes used instead of fall of potential. (See *Potential, Fall of*.)

Potential, Electric — — The power of doing electric work.

Electric level.

Electric potential can be best understood by comparison with the case of a liquid such as water.

The ability of a water supply or source to do work depends:

- (1.) On the quantity of water.
- (2.) On the level of the water, as compared with some other level; or, in other words, on the *difference between the two levels*.

In a like manner the ability of electricity to do work depends:

- (1.) On the quantity of electricity.
- (2.) On the electric potential at the place where the electricity is produced, as compared with that at some other place; or, in other words, on the *difference of potential*.

In the case of water flowing through a pipe, when its flow has been fully established, the quantity which passes in a given time is the same at any cross-section of the pipe.

In the case of electricity, the quantity of electricity flowing through any conductor, or part of a circuit, is the same at any cross-section. A galvanometer introduced into a break in any part of the conductor would show the same strength of current.

But, though the quantity of water which passes is the same at any cross-section of a pipe, the *pressure per square inch* is not the same, even in the case of a horizontal pipe of the same diameter throughout, but becomes less, or suffers a *loss of head*, or *difference of pressure*, at any two points along the pipe. This difference of pressure causes the flow of water between these two points against the *resistance of the pipe*.

So, too, in the case of a conductor carrying an electric current, when the full current strength has been established, the quantity of electricity that passes is the same at all cross-sections.

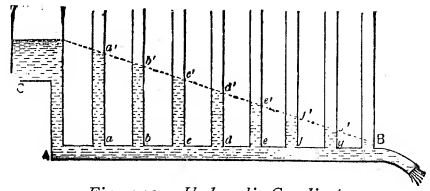

Fig. 449. Hydraulic Gradient.

The electric pressure or potential, however, is by no means the same at all points in the conductor, but suffers a loss of electric head or level, in the direction in which the electricity is flowing. It is this electric head or level, or difference of electric potential, that causes the electricity to flow against the resistance of the conductor.

These analogies can be best shown by the following illustration:

In Fig. 449, a reservoir, or source of water, at C, communicates with the horizontal pipe A B, furnished with open vertical tubes at a, b, c, d, e, f, g, and B. If the outlet at B, is closed, the level of the water in the communicating vessels is the same as at the source; but if the liquid escape freely from B, the level of the water in the branch pipes will be found on the inclined dotted line, or at a', b', c', d', e', f', g', which may be called the *hydraulic gradient*.

The pressure per square inch, at any cross section of the horizontal pipe, which is measured by the height of the liquid in the vertical pipe at that point, *decreases in the direction in which the liquid is flowing*. The force that urges the liquid

through the pipe between any two points, may be called the *liquid-motive force* (*Fleming*) and is measured by the *difference of pressure* between these points.

In Fig. 450, the dynamo-electric machine at D, has its negative pole grounded, and its positive pole connected to a long lead, A B, the positive pole of which is also grounded. A fall of potential, represented by the inclined dotted line, occurs between A and B, in the direction in which the electricity is flowing.

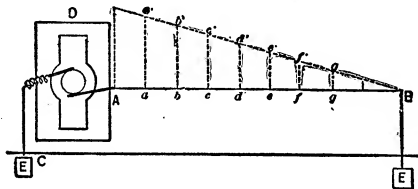

Fig. 450. Fall of Electric Potential.

The dynamo-electric machine may be regarded as a pump that is raising the electricity from a lower to a higher level, and passing it through the lead A B. The electric pressure or potential producing the flow is greatest near the dynamo and least at the further end, the differences at the points a, b, c, d, e, f, and g, being represented by the vertical lines a a', b b', c c', d d', e e', f f', and g g'.

The electricity flows between any two points as a and b, in the conductor A B, in virtue of the difference of electric pressure or potential between these two parts, or the difference between a a' and b b'.

Differences of potential must be distinguished from differences in electric charge, or *electrostatic density*. If two conductors at different potentials are connected by a conductor, a current will flow through this conductor. When their potential is the same, *no current flows*. The density of a charge is the quantity of electricity per unit of area.

The electric potential is the same at all points of an insulated charged conductor; the density is different at different points, except in the case of a sphere. The potential, however, is the same, since no current flows, or the charge does not redistribute itself. The density on an insulated, isolated sphere, is uniform over all parts of the surface, and its potential is the same at all points. If now the sphere be approached to another body, its density will vary at different parts of its sur-

face, and while the charge is redistributing itself so as to produce these differences in density the potential will vary. As soon, however, as this redistribution is effected and no further current exists, the potential is the same over all points, though the density differs at different points.

An electric source not only produces but also maintains a difference of potential. In the case of the flow of liquid in a pipe, if a continuous current of the liquid be maintained from the higher level in the reservoir to a lower level, as, for example, by means of a pump, it must flow through the pump to the reservoir, from the lower level towards the higher level. In case of an electric source, since the thing called electricity flows through a closed circuit, if its direction of flow in that part of the circuit external to the source—*i. e.*, in the external or useful current—be from a higher to a lower level, then its flow through the remainder of the circuit—*i. e.*, through the source—must be from the lower to the higher level. Since, however, the electrical potential of a body represents the work the electricity is capable of doing, the work done by the electricity may be regarded as being that done when it passes from the higher to the lower level.

Potential, Electrostatic — —The power of doing work possessed by a unit quantity of positive electricity charged or residing on an insulated body.

Potential, Electrostatic, Difference of — —Difference of potential of an electric charge. (See *Potential, Difference of, Electrostatics*.)

Potential Energy.—(See *Energy, Potential*.)

Potential, Fall of — —A decrease of potential in the direction in which an electric current is flowing, proportional to the resistance when the current is constant. (See *Potential, Electric*.)

Potential Galvanometer.—(See *Galvanometer, Potential*.)

Potential Indicator.—(See *Indicator, Potential*.)

Potential, Magnetic — —The amount of work required to bring up a unit north-seeking magnetic pole from an infinite distance to a given point in a magnetic field.

Potential of Conductor, Methods of Varying — — (See *Conductor, Potential of, Methods of Varying.*)

Potential of Conductors.—(See *Conductor, Potential of.*)

Potential, Negative — — That potential in the circuit external to the source towards which the electric current flows.

Generally the lower potential, or lower level.

Potential, Positive — — That potential in the circuit external to the source, from which the electric current flows.

The higher potential or higher level.

Potential, Uniform — — A potential that does not vary.

A constant potential. (See *Potential, Constant.*)

An electric source is said to generate a uniform potential when it maintains a constant difference of potential at its terminals.

Potential, Unit Difference of — — Such a difference of potential between two points that requires the expenditure of one erg of work to bring a unit of positive electricity from one of these points to the other, against the electric force. (See *Erg.*)

The practical unit of difference of potential is the volt. (See *Volt.*)

Potential, Zero — — An arbitrary level from which electric potentials are measured.

As we measure the heights of mountains from the arbitrary mean level of the sea, so we measure electric levels from the arbitrary level of the potential of the earth.

Potentiometer.—An apparatus for the galvanometric measurement of electromotive forces, or differences of potential, by a zero method. (See *Method, Null or Zero.*)

In the potentiometer the difference of potential to be measured is balanced or opposed by a known difference of potential, and the equality of the balance is determined by the failure of one or more galvanometers, placed in shunt circuits, to show any movement of their needles.

The principle of operation of the potentiometer will be understood from an inspection of Fig. 451. A secondary battery S, has its terminals con-

nected to the ends of a uniform wire A B, of high resistance called the *potentiometer wire*. There will, therefore, occur a regular drop of potential along this wire, which, since the wire is uniform, will be equal per unit of length. This drop of potential can be shown by connecting the terminals of a delicate galvanometer, generally of high resistance, to different parts of the wire, when the deflection of the needle will be propor-

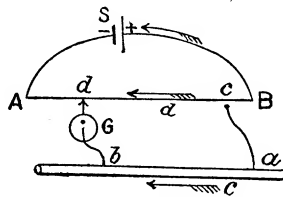

Fig. 451. Potentiometer.

tional to the drop of potential between the two points of the wire touched. If, now, the terminals of a *standard cell* be inserted in the circuit of the galvanometer, so as to oppose the current taken from the potentiometer wire, and the contacts of the potentiometer wire be slid along the wire until no deflection of the galvanometer needle is produced, the drop of potential between these two points on the wire will be equal to the difference of potential of the standard cell. (See *Cell, Voltaic, Standard.*)

Suppose, now, it be desired to measure the difference of potential between two points a and b, on the wire C, through which a current is flowing. Connect the points b and d, and a and c, as shown, with the delicate high resistance galvanometer G, in either of them. Now slide c, towards d, until the needle of G, shows no deflection. The potential between a and b, is then equal to that between c and d.

Potentiometer Wire.—(See *Wire, Potentiometer.*)

Power.—Rate of doing work.

Mechanical power is generally measured in horse-power, which is equal to work done at the rate of 550 foot-pounds per second.

The C. G. S. unit of power is one erg per second.

The practical unit of power is the watt, or 10,000,000 ergs per second. The kilowatt is even more frequently used as the unit of power than the watt. (See *Power, Unit of.*)

Power, Absorptive — — The property

possessed by many solid bodies of taking in and condensing gases within their pores.

Carbon possesses marked absorptive powers. The absorption of gases in this manner by solid bodies is known technically as the *occlusion of gases*. (See *Gas, Occlusion of*.)

One volume of charcoal, at ordinary temperatures and pressures, absorbs of

Ammonia.....	90	volumes
Hydrochloric acid.....	85	"
Sulphur dioxide.....	65	"
Hydrogen sulphide.....	55	"
Nitrogen monoxide.....	40	"
Carbonic acid gas.....	35	"
Ethylene.....	35	"
Carbon monoxide.....	9.42	"
Oxygen.....	9.25	"
Nitrogen.....	6.50	"
Hydrogen.....	1.25	"

—(*Saussure*.)

Power, Candle — —An intensity of light emitted from a luminous body equal to the light produced by a standard candle. (See *Candle, Standard*.)

The light-giving power of one standard candle.

Power, Candle, Nominal — —A term sometimes applied to the candle-power taken in a certain favorable direction.

This term is generally used in arc lighting. In the ordinary arc lamp the greatest amount of light is emitted at a particular point, viz., from the crater in the upper or positive carbon. (See *Arc, Voltaic*.)

Power, Candle, Rated — —A term sometimes used for nominal candle-power.

Power, Candle, Spherical — —The average or mean value of candle power taken at a number of points around the source of light.

Power, Conducting — —The ability of a given length and area of cross-section of a substance for conducting light, heat, electricity or magnetism, as compared with an equal length and area of cross-section of some other substance taken as a standard.

Power, Conducting, for Electricity — —The ability of a given length and area of

cross-section of a substance to conduct electricity, as compared with an equal length and area of cross-section of some other substance, such as pure silver or copper.

No substance is known that does not offer some *resistance* to the passage of an electric current.

The following table is taken from Sylvanus P. Thompson's "Elementary Lessons in Electricity and Magnetism":

GOOD CONDUCTORS.

Silver,	Other metals,
Copper,	Charcoal.

PARTIAL CONDUCTORS.

Water,	Wood,
The human body,	Marble,
Cotton,	Paper.

NON-CONDUCTORS.

Oils,	Gutta-percha,
Porcelain,	Shellac,
Dry wood,	Ebonite,
Silk,	Paraffine,
Resins,	Glass,

Dry air.

Heat decreases the conducting power of elementary substances. This decrease in the conducting power is approximately proportional to the increase of temperature. Carbon is an exception to the law, being a better conductor at a red or white heat than when cold.

The resistance of some alloys, such as German silver and platinoid, is but little affected by moderate changes of temperature. These alloys are, therefore, employed in the construction of resistance coils.

At a red heat insulators become fairly good conductors of electricity.

At very low temperatures the conducting powers of the metals increase.

Wroblewski has shown that at extremely low temperatures copper increases in its conducting power for electricity. He cooled copper to —200 degrees C., the temperature of the solidification of nitrogen, and found that at this temperature its conducting power increased to about nine times its conducting power at 0 degrees C.

It may be remarked here that at exceedingly low temperatures a metal would take in or absorb heat from the surrounding medium with very great rapidity. In this sense it might be said that

its conducting power for heat was greatly increased.

Kohlrausch estimates the conducting power of distilled water at .0000000025, that of mercury being taken as unity.

The best conductors of electricity are the best conductors of heat.

This fact is well illustrated by the following table from Ayrton :

RELATIVE CONDUCTIVITIES PER CUBIC UNIT.

Name of Metal.	Electricity.	Heat.
Silver, annealed.....	100	100
Copper, ".....	94.1	74.8
Gold, ".....	73	54.8
Platinum.....	16.6	9.4
Iron.....	15.5	10.1
Tin.....	11.4	15.4
Lead.....	7.6	7.9
Bismuth.....	1.1	1.8

The electric conductivity of porous conductors decreases much more rapidly than the heat conductivity.

Practically perfect insulators for electricity can be obtained, but are unknown for heat.

Edlund believes the universal ether to be almost a perfect conductor. He bases this belief on the phenomena of sun spots, the occurrence of which is almost immediately followed by the occurrence of magnetic disturbances on the earth.

Lodge regards the luminiferous ether as being almost a perfect non-conductor, because he thinks that conductors must be opaque. It may be suggested in this connection that Edlund's hypothesis as to the conductivity of magnetic effects through the ether is also capable of an explanation by the effects of magnetic induction.

The conducting power for alternating currents is not the same as for steady currents. When the alternations become very high, the difference between these conducting powers of the metals becomes almost inappreciable.

Iron is an enormously worse conductor of electricity than copper for rapidly alternating currents, at least when the alternations are not too great. When, however, the alternations are extremely high, such as those which are produced by the discharge of a Leyden jar or lightning flash, the iron is as good a conductor as the copper. The reason for this is evident. The discharge in such cases keeps to the extreme outer

layer of the conductor, so that the composition of the substance is practically of no effect.

Hughes has shown that the resistance of an iron telephone line of the usual diameter, to periodic currents of about 100 per second, is somewhat more than three times its resistance for steady currents.

There is no such thing as conduction of electricity in gases. Electricity makes its way through a gas by a sudden piercing of the dielectric, or, in other words, by a disruptive discharge. (See *Discharge, Disruptive*.) In such a disruptive discharge it may be assumed that the gas becomes a conductor of electricity while the discharge is passing. It would then partake of the nature of an electrolytic conductor, since the discharge takes place by means of a true locomotion of atoms. (See *Conduction, Electrolytic*.)

Power, Conducting, for Heat — — The ability of a substance to transmit heat through its mass.

The metals are good conductors of heat. They are also good conductors of electricity. The conducting powers for heat and electricity are nearly identical. As the temperature of a body increases, its conducting power for heat is decreased. Carbon forms an exception to this statement.

The flow of heat across a wall formed of a homogeneous material, the exposed faces of which are of equal extent and are maintained at a constant difference of temperature, takes place in accordance with the following laws:

- (1.) The rate of flow across all perpendicular sections is the same.
- (2.) A uniform drop of temperature occurs from one side of the wall to the other in the direction in which the flow is taking place.
- (3.) The rate of flow is proportional to the difference in temperature.

The similarity between the laws of the flow of heat under the circumstances just named and the flow of electricity through a conductor is evident; the electrical current being the same in all parts of the circuit, a drop of potential occurring in the direction in which the current is moving, and the flow being proportional to the difference of potential.

Power, Conducting, Tables of — — Tables in which the relative conducting

powers of different substances are given. (See *Resistance, Tables of.*)

Power, Electric — — Power developed by means of electricity.

Power, Electric, Distribution of — — The distribution of electric power by means of any suitable system of generators, connecting circuits and electric motors.

Power, Electric Transmission of — — The transmission of mechanical energy by converting it into electric energy at one point or end of a line, and reconverting it into mechanical energy at some other point on the line. (See *Energy, Electric, Transmission of.*)

Power, Horse — — A rate of doing work equal to 550 foot-pounds per second, or 33,000 foot-pounds per minute.

1 horse-power = 745.94×10^7 ergs per second.

(See *Erg.*)

“ = 745.941 watts. (See *Watt.*)

“ = 42.746 lb. Fahr. heat units per min. (See *Units, Heat.*)

“ = 23.748 lb. Cent. heat units per min. (See *Units, Heat.*)

Power, Horse, Electric — — Such a rate of doing electric work as is equal to 746 watts or 746 volt-coulombs per second.

This rate is equivalent to 33,000 foot-pounds per minute, or 550 foot-pounds per second.

Just as 1 pound of water raised through the vertical distance of 1 foot requires the expenditure of a foot-pound of energy, so 1 coulomb of electricity acting through the difference of potential of 1 volt requires a certain amount of work to be done on it. (See *Coulomb, Volt, Potential, Electric.*)

This amount is called a volt-coulomb or joule, and measured in foot-pounds is equal to .737324 foot-pounds. The volt coulomb, or joule, is therefore the unit of electric work, just as the foot-pound is the unit of mechanical work.

The electric work of any circuit in joules is equal to the product of the volts by the coulombs.

If we determine the rate per second at which the coulombs pass, and multiply this product by the volts, we have a quantity which represents the electrical power, or rate of doing electrical work.

But 1 ampère is equal to 1 coulomb per second; therefore, if we multiply the current in ampères by the difference of potential in volts, the product is equal to the electrical power or rate of doing electrical work.

The product of an ampère by a volt is called a volt-ampère, or a watt.

One watt = .0013406 horse-power, or

One horse-power = 745.941 watts.

Therefore the electrical horse-power = $\frac{CE}{746}$,

where C = the current in ampères and E = the difference of potential in volts.

Power, Multiplying, of Shunt — — (See *Shunt, Multiplying Power of.*)

Power of Periodic Current.—(See *Current, Periodic, Power of.*)

Power, Portative — — The carrying power of a magnet. (See *Magnet, Portative Power of.*)

Power, Projecting, of Magnet — — The power a magnet possesses of throwing or projecting its lines of magnetic force across an intervening air space or gap.

The greater the air space the greater the magnetic reluctance, and consequently the greater the magnetizing force required to overcome it. Magnets of great projecting power are generally of great length, to accommodate the long coils of wire required.

Power, Resuscitating, of Secondary Battery Cell — — The power possessed by an apparently completely discharged secondary or storage cell of furnishing additional current after a protracted rest.

This resuscitating power is probably due to depolarization. It is therefore present in primary as well as in secondary batteries.

Power, Stray — — That part of the power employed in driving a dynamo, which is lost through friction, air churning or air currents, eddy currents, hysteresis, etc.

Power, Thermo-Electric — — A number which, when multiplied by the difference of temperature of a thermo-electric couple, will give the difference of potential thereby generated in micro-volts. (See *Diagram, Thermo-Electric.*)

Power, Units of — — Various units employed in the measurement of power.

The following table of units of power is taken from Hering's work on dynamo-electric machines.

Unit of Power.

1 erg per second.	= .0000001 watt.
1 watt, or 1 volt-ampère, or 1 joule per second, or 1 volt-coulomb per second.	= 1000000 ergs per second.
“	= 44.2394 foot-pounds per min.
“	= 6.11622 kilogram - metres per min.
“	= .0573048 lb.-Fah., heat unit per min.
“	= .318360 lb.-Cent., heat unit per min.
“	= .0144402 klgr.-Cent. heat unit per min.
“	= .0013592 metric horse-power.
“	= .0013406 horse-power.
1 foot-pound per min.	= 226043 ergs per second.
“	= .0226043 watt.
“	= .13825 kilogram-metre per min.
“	= .00003072 metric horse-power.
“	= .000030303 horse-power.
1 kilogram - metre per min.	= 1635000 ergs per second.
“	= .163500 watt.
“	= 7.23314 foot-pounds per min.
“	= .0002222 metric horse-power.
“	= .0002192 horse-power.
1 metric horse-power, or 1 French horse-power, or 1 cheval-vapeur, or 1 force de cheval, or 1 Pferdekraft. = 735 75 × 10 ⁷ ergs per second.	
“	= 735.750 watts.
“	= 32549.0 foot-pounds per min.
“	= 4500 kilogram-metres per min.

1 metric h.-p., etc. = 42.162 lb.-Fah., heat units per min.	
“ = 23.423 lb.-Cent., heat units per min.	
“ = 10.625 klg.-Cent., heat units per min.	
“ = .98634 horse-power heat units per min.	
1 horse-power. = 745.94 × 10 ⁷ ergs per second.	
“ = 745.941 watts.	
“ = 33000 foot-pounds per min.	
“ = 4562.33 kilogram - metres per min.	
“ = 42.746 lb.-Fah., heat units per min.	
“ = 23.748 lb.-Cent., heat units per min.	
“ = 10.772 klg. - Cent., heat units per min.	
“ = 1.01385 metric horse-power.	
1 lb.-Fah., heat unit per min. = 17.45 × 10 ⁷ ergs per sec.	
“ = 17.4505 watts.	
“ = .23718 metric horse-power.	
“ = .023394 horse-power.	
1 lb. Cent., heat unit per min. = 31.41 × 10 ⁷ ergs per sec.	
“ = 31.4109 watts.	
“ = .04269 metric horse-power.	
“ = .042109 horse-power.	
1 klgr.-Cent., heat unit per min. = 69.25 × 10 ⁷ ergs per sec.	
“ = 69.249 watts.	
“ = .09412 metric horse-power.	
“ = .092835 horse-power.	

Poynting's Law.—(See *Law, Poynting's*.)

Practical Unit of Inductance, or Self-Induction.—(See *Inductance, or Self-Induction, Practical Unit of*.)

Practical Unit of Magneto-Motive Force.—(See *Force, Magneto-Motive, Practical Unit of*.)

Practical Units.—(See *Units, Practical*.)

Pressel.—A press switch or push connected to the end of a flexible, pendant conductor.

Pressure Wires.—(See *Wires, Pressure*.)

Primary Battery.—(See *Battery, Primary*.)

Primary, Breaking the — —Breaking or opening the circuit of the primary of an induction coil. (See *Primary, The.*)

Primary Coil.—(See *Coil, Primary.*)

Primary, Making the — —Closing or completing the circuit of the primary of an induction coil. (See *Primary, The.*)

Primary Plate Condenser.—(See *Plate, Primary, of Condenser.*)

Primary Spiral.—(See *Spiral, Primary.*)

Primary, The — —That conductor in an induction coil, or transformer, which receives the impressed electromotive force, or which carries the inducing current.

On changes in the current intensity in the primary, currents are induced in the secondary. (See *Induction, Electro-Dynamic. Coil, Induction. Transformer.*)

Prime Conductor.—(See *Conductor, Prime.*)

Prime Motor.—(See *Mover, Prime.*)

Prime Mover.—(See *Mover, Prime.*)

Printer, Stock, Callahan's — —A form of printing telegraph used in sending stock quotations telegraphically. (See *Telegraphy, Printing. Ticker, Stock.*)

Printer, Stock, Phelps' — —A form of printing telegraph used in sending stock quotations telegraphically. (See *Ticker, Stock. Telegraphy, Printing.*)

Probe, Electric — —A metallic conductor inserted in the body of a patient in order to ascertain the exact position of a bullet, or other foreign metallic substance.

Two conductors are placed parallel to each other, and are separated at the extremity of the probe by any suitable insulating material. On contact with the metallic substance, an electric bell is rung by the closing of the circuit, or the same thing is more readily detected by the deflection of the needle of a galvanometer, or by a telephone placed in the circuit.

Process, Electrotyping — —(See *Electrotyping, or the Electrotype Process.*)

Processes of Carbonization.—(See *Carbonization, Processes of.*)

Production of Electricity by Light.— (See *Electricity, Production of, by Light.*)

Prognosis, Electric — —In electro-therapeutics, a prognosis, or prediction of the fatal or non-fatal termination of a disease, from an electro-diagnosis based on the exaggerated or diminished reactions of the excitable tissues of the body when subjected to the varying influences of electric currents. (See *Diagnosis, Electro.*)

Projections, Pacinotti — —Radial projections or teeth in an armature core extending from the central shaft, so as to form slots, pockets, or armature chambers, for the reception of the armature coils.

The term Pacinotti projections was given to these teeth because they were first introduced by Pacinotti in his dynamo-electric machine.

Projector, Mangin — —A special form of search light.

The Mangin reflector consists of a concavo-convex mirror, the convex surface of which is silvered and acts as a reflector. The radii of curvature of the two surfaces are such that the light undergoes the two refractions, *i. e.*, on entering and on passing out of the mirror, in such a manner as to pass out of the mirror in absolute parallelism, and thus destroy all aberration.

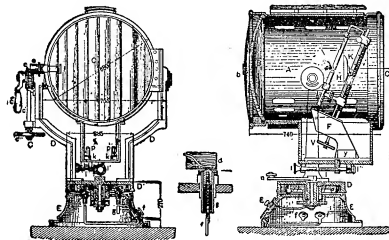

Fig. 452. Mangin Projector.

The Mangin projector is shown in longitudinal and in cross-section in Fig. 452, and the projector B, is placed in one end of the cylinder A, furnished with the openings for the ventilation of the chamber.

The cylinder is supported on trunnions, and by means of screws can be given any desired inclination, in a manner which will be readily understood from an inspection of the drawing.

The source of light is an arc lamp of the focusing type. A small disc is placed in front of the

arc in order to stop the direct light from the arc which would have divergent rays. The door C, is formed of a number of cylindrical lenses, placed parallel to one another, which cause the rays to diverge horizontally, when so desired.

Prony Brake.—(See *Brake, Prony*.)

Proportional Coils.—(See *Coils, Proportional*.)

Proportionate Arms.—(See *Arms, Proportionate*.)

Proportionate Arms of Electric Bridge.—(See *Arms, Proportionate*.)

Prostration, Electric — —Physiological exhaustion or prostration, resembling that produced by sunstroke, resulting from prolonged exposure to the radiation of an unusually large voltaic arc. (See *Sunstroke, Electric*.)

Protection, Electric, of Houses, Ships and Buildings Generally — —Means for protection against the destructive effects of a lightning discharge, consisting essentially in the use of lightning rods. (See *Rod, Lightning*.)

Protection, Electric, of Metals — —(See *Metals, Electrical Protection of*.)

Protective Sheath.—(See *Sheath, Protective*.)

Protector, Cable — —A device for the safe discharge of the static charge produced on the metallic sheathing of a cable, or on conductors surrounding or adjacent to the cable, consequent on changes in the electromotive force applied to the conducting core of such cable.

The cable protector is provided for the purpose of preventing the discharge of the charge from piercing and thus injuring the insulation of the cable itself.

Protector, Comb — —A term sometimes applied to a lightning protector or arrester, in which both the line and ground plates are furnished with a series of teeth, like those on a comb. (See *Arrester, Lightning*.)

Protector, Voltaic Battery — —A device for automatically disconnecting a voltaic battery, whenever the circuit in which it is placed becomes grounded.

The battery protector is used in systems of electric gaslighting, where, unless great care is exercised in insulating the circuits, considerable annoyance is often experienced from the readiness with which grounds are established. This arises from the high electromotive force of the spark obtained from the spark coil, piercing the insulation and establishing a ground through the gas pipes.

Protoplasm, Effects of Electric Currents on — —Contractions observed in all protoplasm on the passage of an electric current through it.

Protoplasm, the basis of plant and animal life, or the jelly-like matter that fills all organic cells, whatever may be the origin of such cells, suffers contraction when traversed by an electric current.

An increased activity in the movements of a form of microscopic life called the *amœba* is occasioned by slight shocks from an induction coil; stronger discharges produce tetanic contractions, with, in some cases, expulsion of food or even of the nucleus. A uniform strength of current produces contraction and imperfect tetanus.

Pull.—A contact maker, similar in general construction to a push button, but operated by means of a pulling rather than a pushing force.

The pull is preferable to the push in exposed positions, such as outer doors, where moisture is apt to injure pushes.

Pull, Chain — —A chain pendant attached to a pendant burner for the movement of the wipe-spark spring and the ratchet in an electrically lighted gas burner.

Pull, Door Bell, Electric — —A circuit-closing device attached to a bell pull and operated by the ordinary motion of the pull.

Pull, Electric Bell — —A circuit-closing device operated by a pull.

Fig. 453 shows a form of electric bell pull. On pulling the bell handle, contact springs, that rest on a ring of insulating material when the

pull is in its normal position, are brought into contact with a metal ring, thus completing the cir-

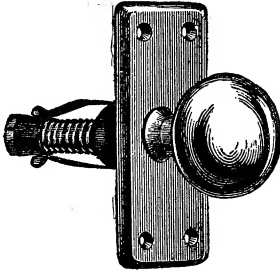

Fig. 453. Electric Bell Pull.

cuit. The bell pull is often used to replace the ordinary push button.

Pulley, Driven — —A pulley attached to the driven shaft. (See *Mover, Prime.*)

Pulley, Driving — —A pulley attached to the driving shaft. (See *Mover, Prime.*)

Pulsating Current.—(See *Current, Pulsating.*)

Pulsation.—A quantity of the nature of an angular velocity, equal to 2π multiplied by the frequency of the oscillation, or, equal to 2π divided by the duration of a single period.

Pulsatory Current.—(See *Current, Pulsatory.*)

Pulsatory Magnetic Field.—(See *Field, Magnetic, Pulsatory.*)

Pulse, Electrical — —An electric oscillation.

A momentary flow of electricity from a conductor, which gradually varies from the zero value to the maximum, and then to the zero value again, like a pulse or vibration in an elastic medium.

Electric pulses are set up in conductors connected with the coatings of a Leyden jar, on the discharge of the same. Such pulses produce a series of electrical oscillations, which move alternately backwards and forwards, until the discharge is gradually dissipated. (See *Oscillations, Electric.*)

The circumstances influencing the rate of propagation of an electric pulse through different parts of a closed circuit, according to Lodge, are—

(1.) The extra inertia, or the so-called magnetic susceptibility in the conducting substance, especially at its outer parts.

(2.) An undue constriction or throttling of the medium through which the disturbance is passing.

(3.) The nature of the insulating medium.

Pump, Air, Geissler Mercurial — —
A mercurial air pump, in which the vacuum is attained by the aid of a Torricellian vacuum.

In the *Geissler Mercury Pump*, Fig. 454, a vacuum is obtained by means of the Torricellian vacuum produced in a large glass bulb that forms the upper extremity of a *barometric column*. The lower end of this tube or column is connected with a reservoir of mercury by means of a flexible rubber tube. To fill the bulb with mercury the reservoir is raised above its level, *i. e.*, above thirty inches, the air it contains being allowed to escape through an opening governed by a stopcock. The vessel to be exhausted is connected with the bulb, and by means

of a two-way exhaustion cock, communication can be made with the bulb, when it contains a Torricellian vacuum, and shut off from it while its air is being expelled.

In actual practice the mercury is mechanically pumped into the barometric column, and the valves are opened either by hand, or automatically by electrical means.

Pump, Air, Mechanical — —A mechanical device for exhausting or removing the air from any vessel.

An excellent form of air pump is shown in Fig. 455, which is a drawing of Bianchi's pump.

Three valves, all opening upwards, are placed

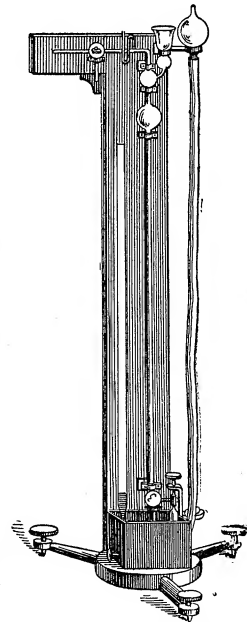

Fig. 454. Geissler's Mercurial Air Pump.

at the top and bottom of the cylinder, and in the piston, respectively. These valves are mechanically opened and closed at the proper moment by the movements of the piston, *i. e.*, their action is *automatic*. This enables a much higher vacuum to be obtained than when the valves open and close by the tension of the air.

Mechanical pumps are unable to readily produce the high vacua employed in most electric lamps. Mercury pumps are employed for this purpose. (See *Pump, Air, Mercurial*.)

Pump, Air, Mercurial — — A device for obtaining a high vacuum by the use of mercury.

Mercury pumps are in general of two types of construction, viz. :

(1.) The Geissler pump.

(2.) The Sprengel pump. (See *Pump, Air, Geissler Mercurial*. *Pump, Air, Sprengel's Mercurial*.)

Pump, Air, Sprengel's Mercurial — — A mercurial air pump in which the vacuum is obtained by means of the fall of a stream of mercury.

In the Sprengel mercury pump, Fig. 456, the fall of a mercury stream causes the exhaustion of a reservoir connected with the vertical tube, by the mechanical action of the mercury in entangling bubbles of air. These bubbles are largest at the beginning of the exhaustion, but become smaller and smaller near the end, until, at last, the characteristic metallic click of mercury or other liquid falling in a good vacuum

is heard. The exhaustion may be considered as completed when the bubbles entirely disappear from the column.

The Sprengel pump produces a better vacuum than the Geissler pump, but is slower in its action.

In actual practice, the mercury that has fallen through the tube is again raised to the reservoir connected to the drop tube by the action of a mechanical pump.

Pumping of Electric Lights.—A term sometimes applied to a pulsating or periodical increase and decrease in the brilliancy of the light.

This action is generally due to the periodic slipping of the belt or other driving mechanism. In the case of arc lamps it may also be caused by the improper action of the feeding device of the lamp.

Puncture, Electro — — The application of electrolysis to the treatment of aneurisms or diseased growths.

The blood is decomposed by the introduction of a fine platinum needle connected with the anode of a battery, and insulated, except near its point, by a covering of vulcanite.

The cathode is a sponge-covered metallic plate.

Puncture, Galvano — — A term sometimes applied to electro-puncture. (See *Puncture, Electro*.)

Punning of Telegraph Pole.—(See *Pole, Telegraphic, Punning of*.)

Push.—A name sometimes applied to a push button, or to a floor push. (See *Push, Floor, Button, Push*.)

Push Button.—(See *Button, Push*.)

Push-Button Rattler. — (See *Rattler, Push-Button*.)

Push, Floor — — A push button placed on the floor of a room so as to be readily operated by means of the foot. (See *Button, Push*.)

Pyknometer.—A term sometimes used for the specific gravity bottle employed in determining the specific gravity of a liquid.

Pyrheliometer.—An apparatus for measuring the energy of the solar radiation.

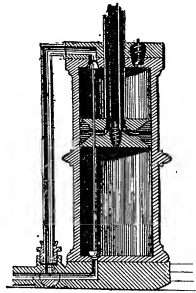

Fig. 455. Barrel of Bianchi's Air Pump.

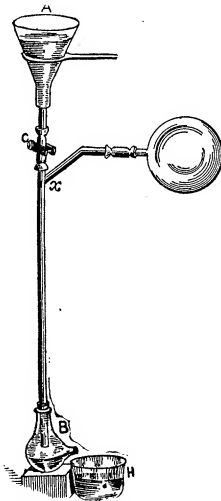

Fig. 456. Sprengel's Mercurial Air Pump.

The pyrheliometer consists essentially of a short cylinder, the area of whose base is accurately determined. The cylinder being filled with a known weight of water, the water surface is exposed for a definite time to the sun's radiation, and the increase in temperature carefully determined. The product of the weight of the water thus heated by the increase in degrees, gives the number of heat units, from which the total energy absorbed is readily calculable. In order to avoid loss by reflection or diffusion from the water surface, it is covered by a layer of lamp-black. (See *Units, Heat. Calorimeter.*)

Pyro - Electricity. — (See *Electricity, Pyro.*)

Pyro-Magnetic Generator or Dynamo. — (See *Generator, Pyro-Magnetic.*)

Pyro-Magnetic Motor. — (See *Motor, Pyro-Magnetic.*)

Pyrometer. — An instrument for determining temperatures higher than those that can be readily measured by thermometers.

Pyrometers are operated in a variety of ways. A common method is by the expansion of a metal rod.

Pyrometer, Siemens' Electric — — An apparatus for the determination of tempera-

ture by the measurement of the electric resistance of a platinum wire exposed to the heat whose temperature is to be measured.

The platinum wire is coiled on a cylinder of fire-clay, so that its separate convolutions do not touch one another. It is protected by a platinum shield, and is exposed to the temperature to be measured while inside a platinum tube.

The resistance of the platinum coil at 0 degree C. having been accurately ascertained, the temperature to which it has been exposed can be calculated from the change in its resistance when exposed to the unknown temperature.

Pyrometer, Siemens' Water — — A pyrometer employed for determining the temperature of a furnace, or other intense source of heat, by calorimetric methods, *i. e.*, by the increase in the temperature of a known weight of water, into which a metal cylinder of a given weight has been put, after being exposed for a given time to the source of heat to be measured.

When copper cylinders are employed, the instrument possesses a range of temperature of 1,800 degrees F.; when a platinum cylinder is used, it has a range of 2,700 degrees F.

Q

Q. — A contraction for electric quantity.

Quad. — A contraction sometimes employed in place of quadruplex telegraphy. (See *Telegraphy, Quadruplex.*)

Quadrant. — A term proposed for the unit of self-induction.

An earth quadrant is equal to 10^9 centimetres.

In the United States the word henry is used for the unit of self-induction. (See *Henry, A.*)

Quadrant Electrometer. — (See *Electrometer, Quadrant.*)

Quadrant Electroscop, Henley's. — (See *Electroscope, Quadrant, Henley's.*)

Quadrant, Legal — — A length equal to 9,978 kilometres, instead of the assumed 10,000 kilometres.

Quadrant, Standard — — A length equal to 10,000 kilometres.

Quadrature, In — — A term employed to express the fact that one simple periodic quantity lags 90 degrees behind another.

The electromotive force of self-induction is said to be in quadrature with the effective electromotive force or current.

Quadruplex Telegraphy, Bridge Method of — — (See *Telegraphy, Quadruplex, Bridge Method of.*)

Qualitative Analysis. — (See *Analysis, Qualitative.*)

Quality or Timbre of Sound. — (See *Sound, Quality or Timbre of.*)

Quantitative Analysis. — (See *Analysis, Quantitative.*)

Quantity Armature.—(See *Armature, Quantity.*)

Quantity, Connection of Battery for — —(See *Battery, Connection of, for Quantity.*)

Quantity Efficiency of Storage Battery.—(See *Efficiency, Quantity, of Storage Battery.*)

Quantity, Unit of Electric — — A definite amount or quantity of electricity called the coulomb. (See *Coulomb.*)

Although the exact nature of electricity is unknown, yet, like a fluid (a liquid or gas), electricity can be accurately measured as to quantity.

A current of 1 ampère, for example, is a current in which one coulomb of electricity passes in every second.

A condenser of the capacity of 1 farad, is large enough to hold 1 coulomb of electricity if forced into the condenser under an electromotive force of 1 volt. (See *Capacity, Electrostatic. Farad. Volt. Ampère.*)

Quiet Arc.—(See *Arc, Quiet.*)

Quiet Discharge.—(See *Discharge, Silent.*)

Quicking Solution.—(See *Solution, Quicking.*)

R

R.—A contraction used for ohmic resistance.

ρ .—A contraction used for specific resistance.

Radial Armature.—(See *Armature, Radial.*)

Radially Laminated Armature Core.—(See *Core, Armature, Radially-Laminated.*)

Radiant Energy.—(See *Energy, Radiant.*)

Radiant Matter.—(See *Matter, Radiant, or Ultra-Gaseous.*)

Radiate.—To transfer energy by means of waves.

Radiating.—Transferring energy by means of waves.

Radiation.—Transference of energy by means of waves.

When an elastic body is set into vibration, whether it be the vibrations that produce light, heat or electricity, energy is charged on the body, and the body will then continue to vibrate until it imparts to some medium surrounding it an amount of energy exactly equal to that originally imparted to itself.

In the case of a sonorous body the energy is transferred from the vibrating body to the air around it. For example, in the case of an elastic metallic wire set into vibration, the wire will continue to vibrate until it does as much work on the surrounding air as was originally done on it, in order to set it into vibration.

In the case of a heated body the energy is transferred from the body to the luminiferous ether around it. For example, in the case of the same wire heated above the temperature of the air, the energy imparted to the molecules of the metal by the source of heat causes them to move towards and from one another. These to-and-fro motions of the molecules cause the surrounding ether to be set into waves, and as much energy is imparted to the ether, as was originally imparted to the wire in order to heat it.

In the case of a luminous body the energy is transferred from the body to the luminiferous ether. For example, if the wire is heated to luminosity by a certain amount of energy imparted to it, the surrounding ether is now set into waves of both light and heat, which differ from one another only in their wave length, and the luminous body will continue to radiate light and heat until it imparts to the surrounding ether an amount of energy exactly equal to that originally imparted to it.

So, too, in the case of a body charged with electricity. If disruptively discharged, the impulsive rush of electricity, so produced, causes the energy charged on it to be radiated as electromagnetic waves into the surrounding ether. The discharging body is, to all intents and purposes, in the same condition as the vibrating elastic wire, and dissipates or radiates its energy in much the same manner.

Radiation, Electro-Magnetic — — The sending out in all directions from a con-

ductor, through which an oscillating discharge is passing, of electro-magnetic waves in all respects similar to those of light except that they are of much greater length. (See *Electricity, Hertz's Theory of Electro-Magnetic Radiations or Waves.*)

Radiation of Electricity.—(See *Electricity, Radiation of.*)

Radiation of Lines of Force.—(See *Force, Lines of, Radiation of.*)

Radical, Compound — —A group of unsaturated atoms.

A group of elementary atoms, some of the bonds of which are open, or not connected or joined with the bonds of other atoms. (See *Atomicity.*)

For example, hydroxyl, HO, is a compound radical, with one of the two bonds of the diatomic oxygen atom, open or unsaturated.

Radical, Simple — —An unsaturated atom with its bond or bonds free.

A single unsaturated atom as distinguished from an unsaturated group of atoms.

Radicals.—Unsaturated atoms or groups of atoms, in which one or more of the bonds are left open or free.

Radicals are either *Simple* or *Compound*.

The radical may be regarded as the basis to which other elements may be added, or as the nucleus around which they may be grouped.

Thus H_2O , forms a complete chemical molecule, because the bonds of all its constituent atoms are saturated, thus $H-O-H$. But $H-O-$, or *hydroxyl*, is a radical, because its oxygen atom possesses one unsaturated or free bond. By combining with the radical (NO_2), it forms nitric acid, thus $H-O-(NO_2)$ or HNO_3 .

During electrolysis, the molecules of the electrolyte are decomposed into two groups of simple or compound radicals, called *ions*. These *ions* are respectively electro-positive and electro-negative, and are called *kathions* and *anions*. (See *Ions, Electrolysis.*)

Radiometer, Crookes' — —An apparatus for showing the action of radiant matter in producing motion from the effects of the reaction of a stream of molecules escaping from a number of easily moved heated surfaces. (See *Matter, Radiant, or Ultra-Gaseous.*)

Radiometer, Electric, Crookes' — — A radiometer in which the repulsion of the molecules of the residual atmosphere takes place from electrified instead of from heated surfaces. (See *Radiometer, Crookes'.*)

Radio-Micrometer, Boys' — —An electrical apparatus for measuring the intensity of radiant heat.

The action of the radio-micrometer depends on the deflection, by a magnetic field, of a suspended thermo-electric circuit composed of three metals, viz.: two bars of antimony and bismuth, or of their alloys, which are soldered side by side to the end of a minute disc or strip of copper foil, as shown in Fig. 457. This disc or foil of copper is

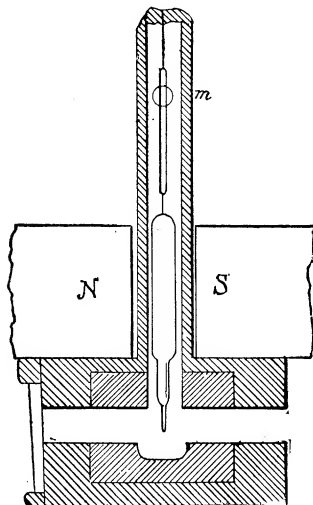

Fig. 457. Boys' Radio-Micrometer.

provided for the purpose of receiving the radiation that is to be measured. The upper ends of the thermo-couple are soldered to the ends of a long, narrow, inverted U-shaped piece of copper wire, which completes the thermo-electric circuit.

The absorption of radiant energy by the copper disc connected to the thermo-electric couple produces an electric current, and the circuit, being suspended in a magnetic field, is at once deflected to a degree dependent on the intensity of the radiation, or of the current generated at the thermo-electric junction.

The means adopted for the suspension of the system are shown in Figs. 457 and 458. A small piece of straight wire is soldered to the up-

per end of the copper stirrup, which completes the thermo-electric circuit. This wire is cemented to the lower end of a glass tube, the upper end of which is provided with a mirror, and the whole suspended, as shown, by a quartz fibre in the field of a powerful magnet.

In a radio-micrometer made by Prof. Boys, the minuteness of the suspended circuit may be judged from the following actual dimensions, viz.: Thermo-electric bars, $\frac{1}{8} \times \frac{1}{60} \times \frac{1}{3000}$ inch; copper circuit of number 36 copper wire, 1 inch long and about $\frac{1}{10}$ inch wide; copper heat-receiving surface, blackened on the face exposed to the radiation, $\frac{1}{10}$ inch in diameter, or $\frac{1}{4} \times \frac{1}{80}$ inch; receiver, $\frac{1}{10}$ inch square, $\frac{1}{3000}$ inch thick; quartz fibre 4 inches long, $\frac{1}{3000}$ inch in diameter.

This instrument, when properly adjusted for extreme sensitiveness, should give clear indications when the blackened surface is warmed but the $\frac{1}{30000000}$ degree Centigrade. It will respond to the heat radiated on the surface of a half penny from a candle flame at a distance of 1,530 feet.

In order to avoid the disturbance due to the magnetic qualities of the antimony and bismuth bars, the central portions of the metallic block, inside which the system is suspended, is made of iron, as shown by the heavier shading in Fig. 457.

This mass of iron serves as a magnetic screen to the thermo-electric bars, but permits the action of the field on the circuit.

Radiophone.—A name sometimes given to the photophone. (See *Photophone*.)

Radiophony.—The production of sound by a body capable of absorbing radiant energy when an intermittent beam of light or heat falls on it.

The action of radiant energy, when absorbed by matter, is to cause its expansion by the consequent increase of temperature. This occurs even when the body is but momentarily exposed to a

flash of light, but the instantaneous expansion thus produced immediately dies away, and by itself is indistinguishable. If, however, a sufficiently rapid succession of such flashes fall on the body, the instantaneous expansions and contractions produce an appreciable musical note.

The sounds so produced have been utilized by Bell and Tainter in the construction of the *Photophone*. (See *Photophone*.)

Railroad, Electric.—A railroad, or railway, the cars on which are driven or propelled by means of electric motors connected with the cars.

The electric current that drives the motor is derived either from storage batteries placed on the cars, or from a dynamo-electric machine, or battery of dynamo-electric machines, conveniently situated at some point on the road. The current from the dynamo is led along the line by suitable electric conductors and is passed into the electric motor as the car runs along the tracks in various ways, viz.:

Systems for the electric propulsion of cars may, therefore, be divided into the dependent system, in which the driving current is obtained from conductors placed somewhere outside the cars, and the independent system, where the current is derived from primary or secondary batteries placed on the cars. (See *Railroads, Electric, Dependent System of Motive Power for. Railroads, Electric, Independent System of Motive Power for.*)

In the dependent system, the conductors which supply the car with current are placed either overhead, on the surface of the road-bed or underground. Thus arise three divisions of the dependent system:

- (1.) The Surface System.
- (2.) The Underground System.
- (3.) The Overhead System.

(1.) *The Surface System.*—By placing one or both rails in the circuit of the dynamo and taking the current from the tracks by means of sliding or rolling contacts connected with the motor.

(2.) *The Underground System.*—By placing the conducting wires parallel to each other in a longitudinally slotted underground conduit in the road-bed, and provided with two central plates, insulated from one another and connected respectively to the motor terminals, and taking the current by means of a traveling brush or roller, called a plow, sled or shoe. On the movement of the car over the track, these traveling contacts touch the

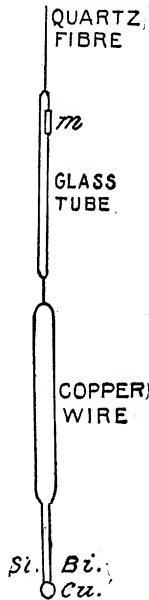

Fig. 458. Boys' Radio-Micrometer.

two parallel line conductors in the conduit and take the electric current therefrom. (See *Plow, Sled.*)

(3.) *The Overhead System.*—By placing the line conductors on poles along the road, and taking the current therefrom by means of suitable traveling contacts called trolleys, or by sliders.

Where a single conductor is employed, the return conductor generally consists of the track itself, or of the track and ground. (See *Trolley.*)

The first method, viz., that of using the tracks alone as conductors, is not much employed.

The use of the track and ground as a return for the current is now very generally employed.

In some systems the track is divided into sections which are successively brought into connection with the main conductors by contacts effected by the attraction between magnets carried on the car and contact pieces of magnetic material placed below the surface. The rail section thus temporarily energized is placed in connection with the motor.

In order to regulate the speed, various devices are employed to vary the current strength in the motor circuit. These devices consist essentially of rheostats or resistances introduced into, or removed from, the motor circuit on the movement by hand of a lever that forms part of the circuit, over contact plates connected to the resistance coils.

In order to change the direction of the car, the direction of rotation of the electric motor is changed. This is effected by some form of reversing gear or mechanism that changes the direction of rotation of the motor, either by shifting the brushes, by changing the field, or by any other means. (See *Telferage. Motor, Electric. Rheostat.*)

Railroads, Absolute Block System for —A block system in which one train only is permitted to occupy a given block at any time. (See *Railroads, Block System for.*)

Railroads, Automatic Electric Safety System for —A system for automatically preventing the approach of two trains at any speed beyond a predetermined distance of each other.

The system consists essentially in the automatic closing of the circuit of an electric motor placed on the locomotive between the steam dome and the sand box. This motor is in circuit with a local battery placed on the cow-catcher, and in-

troduced in the circuit of the motor by a magnet placed on the cow-catcher, as shown in Fig. 459,

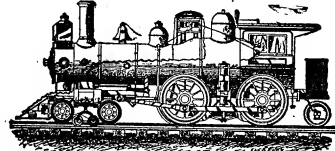

Fig. 459. Locomotive with Safety System.

which represents a locomotive provided with this system.

The magnet is on open circuit with generators placed on the rear car of a second train, or with generators at a bridge or crossing.

By means of double sectional-conductors placed along the track, the generators are automatically closed through the magnet, one conductor being in permanent connection with the magnet, while the other is connected to the generator in the rear car of a second train, at a switch or crossing. The other terminals of the magnet and generators are in permanent electrical connection with the rails, which are employed as return ground conductors.

Fig. 460 shows the application of the safety electric system to a bridge.

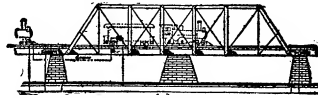

Fig. 460. Safety System for Bridge.

Fig. 461 shows the application of the safety system at grade crossing.

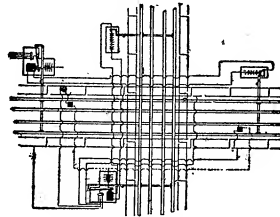

Fig. 461. Safety System for Grade Crossing.

The author is indebted to Mr. E. P. Thompson for cuts and general description.

Railroads, Block System for —A system for securing safety from collisions of moving railroad trains by dividing the road into a number of blocks or sections of a given length, and so maintaining telegraphic communication between towers located at the ends of each of such blocks as to prevent,

by the display of suitable signals, more than one train or engine from being on the same block at the same time.

There are two kinds of railway block systems in common use, viz.:

(1.) The *Absolute Block System*.

(2.) The *Permissive Block System*.

In the absolute system, which is the safer, one train only is permitted on any particular block at a given time.

In the permissive block system more than one train is permitted, under certain circumstances and conditions, to occupy the same block simultaneously, each train then being notified of the fact that it is not alone on the block.

The absolute block system, though expensive to construct and maintain, is the only one that should be permitted by law to exist on roads whose traffic exceeds a certain amount.

An absolute block system is employed on the London Underground Railroad, and on the Pennsylvania Railroad Systems.

The system in use on the New York Division of the Pennsylvania Railroad is as follows:

The road between Philadelphia and Jersey City is divided into some seventy sections, the length of each section being dependent on the amount of

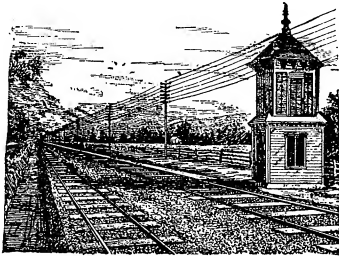

Fig. 462. Block Tower.

daily traffic, thus, between Jersey City and Newark, where the traffic is great, there are some fifteen sections, although the distance is only 7.9 miles.

In each block-tower there are connections with three separate and distinct telegraph lines or circuits, viz.:

(1.) A line or wire called the *train wire*, connecting the block-tower with the General Dispatcher's office at Jersey City. This line is used for sending train orders only.

(2.) A line or wire called the *block wire*, con-

necting each block-tower with the next tower on each side of it.

(3.) A line or wire called the *message wire*, and used for local traffic or business.

The general arrangement of the block-tower is shown in Fig. 462.

Each of the block-towers is sufficiently elevated above the road-bed to afford the operator an unobstructed view of the tracks.

The operator, having ascertained the actual condition of the track, either by observation or by telegraphic communication with the stations on either side of him, gives notice of this condition to all trains passing his station by the display of certain semaphore signals.

The semaphore signals as used on the Pennsylvania Railroad are shown in Figs. 463 and 464.

The form shown in Fig. 463 is used in the abso-

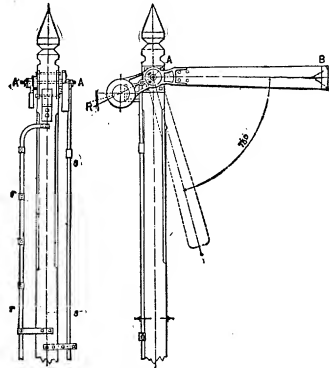

Fig. 463. Semaphore Signal—Absolute System.

lute system, and that shown in Fig. 464 in the permissive system. These signals consist essentially of an upright support provided with a movable arm A B, called the *semaphore arm*, capable of being set in any of two or three positions. The semaphore signal is placed outside the signal tower, often several hundred feet away, but is readily set from the tower in any of the desired positions by the operator, by the movement of rods connected with levers.

In the permissive system, the semaphore arm can be set in three positions, viz.:

(1.) In a horizontal position, or where the semaphore arm makes an angle of 90 degrees with the upright.

(2.) Or it may be dropped down from the horizontal position through an angle of 75 degrees, as shown in Fig. 463.

(3.) Or it may occupy a position exactly inter-

mediate between the first and second, or $37^{\circ} 30'$ below the horizontal, as shown in Fig. 464.

Position No. 1 is the danger signal, and when it is displayed the train may not enter the block it governs.

Position No. 2 shows that the track is clear, and that the train may safely enter the block it governs.

Position No. 3, which is used in the permissive block system, only signifies caution, and permits the train to cautiously enter the block and look out for further signals.

The semaphore arm consists of a light wooden arm, 11 inches wide by $5\frac{1}{2}$ feet in length, painted red or other suitable color that can be easily distinguished by daylight.

By night the positions of the semaphore arm are indicated by colored lights. These lights are

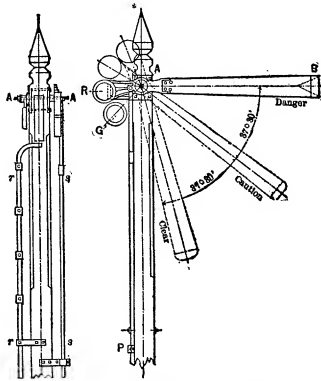

Fig. 464. Semaphore Signal—Permissive System.

operated as follows, viz.: in the absolute system, the semaphore arm A B, pivoted at A, bears at its shorter end a disc or lens of red glass R, and, in the permissive system, below this another disc, provided with an uncolored glass lens, is so supported on a bracket fastened to the upright that when the semaphore arm points to danger the red glass is immediately in front of the lantern; when it points to caution, the green glass is in front of the lantern; but when it points to safety, the lantern is left uncovered save by its uncolored glass.

At night, therefore, when the semaphore arm is set to danger, a red light is displayed; when it points to caution, a green light is displayed; and when it points to safety, a white light is displayed.

In some systems the position of the semaphore

arm is shown at night by means of light reflected from a parabolic mirror, at the focus of which the signal lantern is placed. This method possesses the advantage over other systems of rendering it very improbable that the engineer would mistake an ordinary light for a signal light.

The green light is only used in the permissive block system. In the absolute block system, the semaphore arm has two positions only; viz., danger, or horizontal, and safety, or 75° degrees below the horizontal.

A single arm is used when it is intended to govern a single track only. Where the condition of a number of tracks is to be indicated, several arms are employed, one above the other.

When semaphore signals are placed on each side of a double-track road, the semaphore arm pointing to the right of the vertical support governs the line running to the right.

When the semaphore signals are placed at junctions or switch-crossings, the operator in the signal-tower opens or closes the switches for the tower by the movements of levers that set the switches, and then displays the proper semaphore signal for that crossing or route; red, or danger, if the route is blocked, and white, or safety, if it is clear. Here the interlocking apparatus is employed, which consists in devices by means of which, when a route has once been set up and a signal given for that route, the switches and signals are so interlocked that no signal can possibly be given for a conflicting route.

The signals or switches are operated by means of iron rods passing over rollers or pulleys. These rods are attached by suitable connections to the switch or semaphore signals, and are operated by means of levers from the signal-tower. Switches can be operated as far as 1,000 feet from the tower; signals as far as 2,500 feet.

Colored switch-signals are placed opposite the end of the switches to indicate the positions of the switch. These signals consist of red and white discs for day, and a lantern provided with red and white glasses for night. When the switch on any line is open, the switch-signal shows red; when shut, it shows white. These switch-signals are only used in the yards.

No passenger train is permitted on a block, after another train has passed the signal station, until a dispatch has been received from the station ahead that the train has passed and the block is thus cleared.

As an additional precaution against rear col-

lisions, *tail-lights* are displayed at the ends of the trains. These consist of lanterns placed on each side of the rear end of the last car. These lanterns are furnished with three glass slides. The side of the lantern towards the rear of the car shows a *red* light; that to the front and side of the car shows a green light. The engineer, looking out of the cab, can thus see a green light, which serves as a "*marker*" and indicates to him that his train is intact. By day a green flag, placed in the same position as the lantern, serves the same purpose as a *marker*. An observer on the track, or in the tower, sees the red lights on the rear of the train when it has passed.

Freight trains are now run on separate tracks, except in places where the extra tracks are not yet completed. Here they do not run on schedule time, but are permitted to follow one another at intervals that depend on the condition of the tracks as shown by the signals displayed.

Railroads, Electric, Continuous Overhead System of Motive Power for — —

A variety of the dependent system of motive power for electric railroads in which a continuous bare conductor is connected with the terminals of a generating dynamo, and supported overhead by suitable means, and a traveling wheel or trolley is moved over the same by the motion of the car, in order to carry off the current from the line to the car motor. (See *Railroads, Electric, Dependent System of Motive Power for*.)

Railroads, Electric, Continuous Surface System of Motive Power for — —

A variety of the dependent system of motive power for electric railroads, in which the terminals of the generating dynamo are connected to the continuous bare metallic conductor that extends along the entire track on the surface of the roadway or street, and from which the current is taken off by means of a traveling conductor connected with the moving car. (See *Railroads, Electric, Continuous Underground System of Motive Power for*.)

Railroads, Electric, Continuous Underground System of Motive Power for — —

A variety of the dependent system of motive power for electric railways, in which a continuous bare conductor is placed under-

ground in an open slotted conduit, and the current taken off from the same by means of sliding or rolling contacts carried on the moving car. (See *Railroads, Electric, Dependent System of Motive Power for*.)

Railroads, Electric, Dependent System of Motive Power for — —

A term now generally used for a system of motive power for the propulsion of electric railway cars, in which the electric current is taken from wires or conductors connected with electric sources external to the cars.

A dependent system of motive power for electric railways includes three distinct varieties, namely:

- (1.) The Underground System.
- (2.) The Surface System.
- (3.) The Overhead System.

In all of these systems the bare conductor connected with the terminals of a generating dynamo may form either one continuous wire or it can be divided into separate portions or sections.

The underground system embraces two distinct varieties:

1st. A continuous bare conductor placed in an open slotted conduit.

2d. A sectional bare conductor placed in an open slotted conduit.

In the first variety of the underground system, bare conductors are placed in an open slotted conduit, and connected with the terminals of a dynamo-electric machine which generates the current that is to be employed for the propulsion of the cars. Traveling contacts placed on the car and connected with an electric motor, carry off the current from the bare conductor by rolling or sliding over it.

In the second variety of the underground system, a section of a bare conductor, or bare metallic points that, on the passage of the car over them are automatically connected with the generating dynamo, replace the continuous metallic conductors of the first system.

In the surface system, the wires or conductors that are connected with the generating dynamo, instead of being placed in the underground open slotted conduit, are placed directly on the surface of the street or roadbed and the current carried off from the same by suitable contacts placed on the car.

In most cases, however, in which the surface system is adopted, the conductors that are con-

ected with the generating dynamo do not extend throughout the entire length of the track, but are limited to sections of the track that are suitably connected with the generating dynamo. In some of these systems arrangements are devised, by which the car, as it passes over the track, automatically connects these sections with the generating dynamo while passing over the same, and disconnects them after such sections have been passed.

The overhead system embraces two varieties:

- (1.) A continuous trolley wire.
- (2.) A divided or sectional trolley wire.

In the continuous trolley wire system, the current is taken off from the continuous wire by means of a trolley wheel that moves over the trolley wire.

Such a system is especially suitable for suburban districts or small towns. In such a system the trolley wire is connected with a number of feeder wires that either extend from the generating station the entire length of the line, and are connected with such line at suitable points; or, separate feeders extend from the station to points on the line where they are tapped into the trolley wire.

In the divided or sectional trolley wire system the wire is divided into suitable sections, and feeders extend the entire length of the line and are connected to the central points of each section; or, the feeders extend the entire length of the line and tap into both ends of the section.

The author is indebted to G. W. Mansfield for the principal facts contained in the above descriptive matter.

Railroads, Electric, Divided Overhead System of Motive Power for — —A sectional overhead system of motive power for electric railroads. (See *Railroads, Electric, Sectional Overhead System of Motive Power for.*)

Railroads, Electric, Divided Surface System of Motive Power for — —A sectional system of motive power for electric railroads. (See *Railroads, Electric, Sectional Surface System of Motive Power for.*)

Railroads, Electric, Divided Underground System of Motive Power for — —A sectional system of motive power for electric railroads. (See *Railroads, Electric,*

Sectional Underground System of Motive Power for.)

Railroads, Electric, Double-Trolley System for — —A system of electric railroad propulsion, in which a double trolley is employed to take the driving current from two overhead trolley wires.

The double-trolley system differs from the single-trolley system in that it employs no earth return. The parallel wires also avoid the effects of injurious induction in neighboring telegraph or telephone wires. (See *Railroads, Electric, Dependent System of Motive Power for.*)

Railroads, Electric, Independent System of Motive Power for — —A term for the electric propulsion of railway cars by means of primary or storage batteries placed on the car and directly connected with the motor.

This is called the independent system, because, unlike the dependent system, the energy required for the propulsion of the car is obtained directly from the energy of the electric source placed on the car, instead of, as in the dependent system, outside of the car.

Railroads, Electric, Sectional Overhead System of Motive Power for — —A variety of the dependent system of motive power for electric railroads, in which sections of bare conductors are supported overhead on poles placed along the railroad track, and the current taken off from the same by means of traveling conductors such as the trolley wheel, which is moved over the trolley wire by the motion of the car.

Various systems are employed for connecting the different sections of the trolley wire by means of feeder wires with the generating dynamo. (See *Railroads, Electric, Dependent System of Motive Power for.*)

Railroads, Electric, Sectional Surface System of Motive Power for — —A variety of the dependent system of motive power for electric railroads in which conductors are placed on the roadbed or along the track, and the current taken off from the same by means of contacts connected with the moving car, and so arranged as to automatically switch in such bare sections on the passage

of the car over them, and to switch them out as the car leaves them. (See *Railroads, Electric, Dependent System of Motive Power for.*)

Railroads, Electric, Sectional Underground System of Motive Power for —

—A variety of the dependent system of motive power for electric railroads in which a sectional conductor is placed underground in a slotted conduit, and the current taken from the same by means of sliding or rolling contacts connected with the moving car. (See *Railroads, Electric, Dependent System of Motive Power for.*)

Railroads, Electric, Section Line of —

—Any part of the overhead electric conductors insulated from other parts so as to permit its supply of electric power to be separately controlled.

Railroads, Electric, Signal Service System for —

—The system of electric signals used on railways for ascertaining the condition of the roads, sending instructions to engineers, and conveying intelligence generally from stations along the road to the running trains.

Railroads, Electric, Single-Trolley System —

—A system of electric railroad propulsion in which a single trolley is employed to take the driving current from a single overhead trolley wire.

The earth, or a conductor placed along the track on the roadbed, acts as the return. (See *Railroads, Electric, Dependent System of Motive Power for.*)

Railroads, Permissive Block System for —

—A block system in which more than one train is permitted under given conditions to occupy the same block simultaneously. (See *Railroads, Block System for.*)

Railway, Electric — —An electric railroad. (See *Railroad, Electric.*)

Range, Molecular — —The distance at which the molecules of matter exert a sensible attraction for one another.

This distance has been estimated in the case of zinc and oxygen as equal to about the ten-millionth of a millimetre.

Ratchet-Pendant Argand-Electric Burner.

—(See *Burner, Argand-Electric, Ratchet-Pendant.*)

Ratchet-Pendant Electric Burner.—(See *Burner, Ratchet-Pendant, Electric.*)

Ratchet-Pendant Electric Candle Burner.

—(See *Burner, Ratchet-Pendant Candle Electric.*)

Ratio, Velocity — —A ratio, in the nature of a velocity, that exists between the dimensions of the electrostatic and the electro-magnetic units.

This ratio will be understood from the comparison of the following units. In each case the numerator gives the dimensions in the electrostatic and the denominator the dimensions in the electro-magnetic system :

$$\text{Quantity, } \frac{M^{\frac{1}{2}} L^{\frac{3}{2}} T^{-1}}{M^{\frac{1}{2}} L^{\frac{1}{2}}} = \frac{L}{T} = V .$$

Here the value of the ratio, viz., the *length* divided by the *time*, is clearly in the nature of a velocity, for $V = \frac{L}{T}$.

$$\text{Potential, } \frac{M^{\frac{1}{2}} L^{\frac{1}{2}} T^{-1}}{M^{\frac{1}{2}} L^{\frac{3}{2}} T^{-2}} = \frac{T}{L} = \frac{1}{V} .$$

$$\text{Capacity, } \frac{L}{L^{-1} T^2} = \frac{L^2}{T^2} = V^2 .$$

$$\text{Resistance, } \frac{L^{-1} T}{L^2 T^{-1}} = \frac{T^2}{L^2} = \frac{1}{V^2} .$$

A remarkable similarity exists between the value of the *velocity* expressed in C. G. S. units, and the velocity of light, which is of great significance in the *electro-magnetic theory of light*. (See *Light, Maxwell's Electro-Magnetic Theory of.*)

The velocity of light is 2.9992×10^{10} centimetres per second.

The velocity ratio, v , is 2.9800×10^{10} centimetres per second.

Rattler, Push-Button — —A device connected with a push button to show that the bell connected at a distant point, in the circuit of a push button, rings when the button is pressed.

Ray, Actinic — —A ray of light or other form of radiant energy that possesses the

power of effecting chemical action. (See *Decomposition*.)

All rays of light, and even some of those invisible to the human eye, are *actinic* to some particular chemical substance or another. Whether the ether waves produce the effects of heat, of light or of chemical decomposition depends on the *nature of the material on which they fall, as well as on the character of the waves themselves.*

Ray, Electric (*Raia torpedo*) — —A species of fish named the ray, which, like the electric eel, possesses the power of producing electricity.

The electric organ is situated at the back of the head, and consists of hundreds of polygonal, cellular laminae, supplied with numerous nerve fibres, as shown in Fig. 465. (See *Fishes. Electric.*)

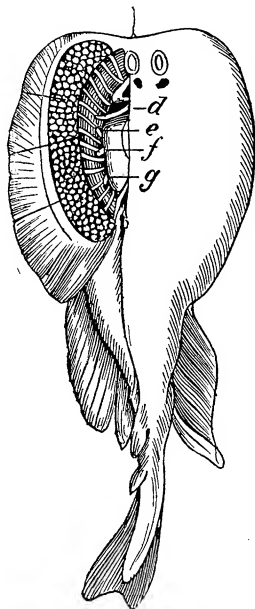

Rayleigh's Form of Clark's Standard Voltaic Cell. — (See *Cell, Voltaic, Standard, Rayleigh's Form of Clark's.*) Fig. 465. *The Raia Torpedo.*

Reaction.—In electro-therapeutics muscular contractions following the closing or opening of an electric circuit.

Reaction Coil.—(See *Coil, Reaction.*)

Reaction of Degeneration.—(See *Degeneration, Reaction of.*)

Reaction of Exhaustion.—(See *Exhaustion, Reaction of.*)

Reaction Principle of Dynamo-Electric Machines.—(See *Machine, Dynamo-Electric, Reaction Principle of.*)

Reaction Telephone.—(See *Telephone, Reaction.*)

Reaction Time.—(See *Time, Reaction.*)

Reaction Wheel, Electric — —(See *Wheel, Reaction, Electric.*)

Reactions, Kathodic and Anodic Electro-Diagnostic — —The reactions which occur at the kathode or anode of an electric source placed on or over any part of a living body.

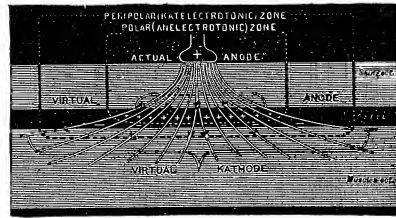

Fig. 466. *Kathodic and Anodic Reactions.*

Fig. 466, from De Watteville's "Medical Electricity" represents what he assumes takes place at the points of entrance and exit of the current in a nerve submitted to the action of the anode of an electric source. Two zones are formed, an anodic and a kathodic zone; the virtual anode is formed by the portion of the skin nearer the nerve, and the virtual kathode by the adjoining muscles. There are thus formed two zones of influence—one immediately around the anode, called the polar or anodic electrotonic zone, and one surrounding this and including the virtual kathode, and called the peripolar, or kathelectrotonic zone.

Reading Telescope.—(See *Telescope, Reading.*)

Real Efficiency of Storage Battery.—(See *Efficiency, Real, of Storage Battery.*)

Real Hall Effect.—(See *Effect, Hall, Real.*)

Recalescence.—The property, possessed by incandescent steel when cooling, of again becoming incandescent after a certain degree of cooling has been reached.

The property of recalescence was first pointed out by Barrett.

A steel wire heated at the middle or near one end to a bright red, and allowed to cool in a dim light, will cool until a low red heat is reached, when it will be observed to reheat at some point in the originally heated portion. This reheating is manifested by a brighter red spot

which moves along the portion originally heated. This reheating is called *recalescence*, and is due to latent heat (potential energy), which, disappearing when the bar was heated, again becomes sensible (kinetic energy) on cooling.

The temperature at which recalescence takes place is sensibly the temperature at which heated steel regains its magnetizability.

Received Current.—(See *Current, Received*.)

Receiver, Gramophone — —The receiver employed in the gramophone. (See *Gramophone*.)

Receiver, Graphophone — —The receiver employed in the graphophone. (See *Phonograph*.)

Receiver, Harmonic — —A receiver, employed in systems of harmonic telegraphy, consisting of an electro-magnetic reed, tuned to vibrate to one note or rate only. (See *Telegraphy, Gray's Harmonic Multiple*.)

Receiver Magnet.—(See *Magnet, Receiving*.)

Receiver, Phonographic — —The apparatus employed in a telephone, phonograph, graphophone or gramophone for the reproduction of articulate speech. (See *Phonograph*.)

Receiver, Telephonic — —The receiver employed in the telephone. (See *Telephone*.)

Receptive Device, Electro — —(See *Device, Electro-Receptive*.)

Receptive Device, Magneto — —(See *Device, Magneto-Receptive*.)

Reciprocal — —The reciprocal of any number is the quotient arising from dividing unity by that number.

Thus, for example, the reciprocal of 4, is $\frac{1}{4}$ or .250.

The conducting power of any circuit is equal to the reciprocal of its resistance; or, in other words, the conducting power is inversely proportional to the resistance.

The following table contains the reciprocals of the numerals up to 100:

TABLE OF RECIPROCAL.

No.	Re-cipro-cal.	No.	Re-cipro-cal.	No.	Re-cipro-cal.	No.	Re-cipro-cal.	No.	Re-cipro-cal.
2	0.5000	22	0.0455	42	0.0338	62	0.0161	82	0.0122
3	0.3333	23	0.0435	43	0.0233	63	0.0159	83	0.0120
4	0.2500	24	0.0417	44	0.0227	64	0.0156	84	0.0119
5	0.2000	25	0.0400	45	0.0222	65	0.0154	85	0.0118
6	0.1667	26	0.0385	46	0.0217	66	0.0152	86	0.0116
7	0.1429	27	0.0370	47	0.0213	67	0.0149	87	0.0115
8	0.1250	28	0.0357	48	0.0208	68	0.0147	88	0.0114
9	0.1111	29	0.0345	49	0.0204	69	0.0145	89	0.0112
10	0.1000	30	0.0333	50	0.0200	70	0.0143	90	0.0111
11	0.0909	31	0.0323	51	0.0196	71	0.0141	91	0.0110
12	0.0833	32	0.0313	52	0.0192	72	0.0139	92	0.0109
13	0.0769	33	0.0303	53	0.0189	73	0.0137	93	0.0108
14	0.0714	34	0.0294	54	0.0185	74	0.0135	94	0.0106
15	0.0667	35	0.0286	55	0.0182	75	0.0133	95	0.0105
16	0.0625	36	0.0278	56	0.0179	76	0.0132	96	0.0104
17	0.0588	37	0.0270	57	0.0175	77	0.0130	97	0.0103
18	0.0556	38	0.0263	58	0.0172	78	0.0128	98	0.0102
19	0.0526	39	0.0256	59	0.0169	79	0.0127	99	0.0101
20	0.0500	40	0.0250	60	0.0167	80	0.0125	100	0.0100
21	0.0476	41	0.0244	61	0.0164	81	0.0123		

—(Clark & Sabine.)

Recoil Circuit.—(See *Circuit, Recoil*.)

Record, Chronograph — —A record made by means of a chronograph for the purpose of measuring and recording small intervals of time. (See *Chronograph, Electric*.)

Record, Gramophone — —The irregular indentations, cuttings or tracings made by a point attached to the diaphragm spoken against, and employed in connection with the receiving diaphragm for the reproduction of articulate speech.

Record, Graphophone — —The record made by the movement of the diaphragm of the graphophone. (See *Phonograph*.)

Record, Phonographic — —The record produced in a phonograph, for the subsequent reproduction of audible articulate speech.

Record, Telephonic — —The record produced by the diaphragm of a receiving telephone.

Various methods have been proposed for obtaining telephonic records, but none of them have yet been introduced into actual commercial use.

Recorder, Chemical, Bain's — —An apparatus for recording the dots and dashes of

a Morse telegraphic dispatch, on a sheet of chemically prepared paper.

A fillet of paper soaked in some chemical substance, such as ferro-cyanide of potassium, is moved at a uniform rate between the two terminals of the line, one of which is iron tipped, so that on the passage of the current, a blue dot, or a dash, will be made on the paper according to the length of time the current is passing.

In order to insure a moist condition of the paper fillet, some deliquescent salt, like ammonium nitrate, is generally mixed with the ferro-cyanide of potassium.

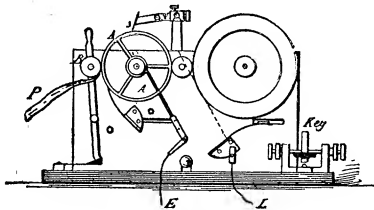

Fig. 467. Bain Recorder.

A Bain recorder is shown in Fig. 467. A, is a drum of brass, tinned on the outside. The paper fillet is drawn from the roll and kept pressed against the cylinder A, by a small wooden roller B. The needle, which is a metallic point, is placed in connection with one end of the line wire, and the brass drum is connected with the other end through the earth. Care must be observed to connect the needle point with the positive electrode, as otherwise the paper will not be marked. (See *Electrolysis*.)

The Bain recorder is now almost entirely replaced by the Morse sounder. (See *Sounder, Morse Telegraphic*.)

Recorder, Morse — — An apparatus for automatically recording the dots and dashes of a Morse telegraphic dispatch, on a fillet of paper drawn under an indenting or marking point on a striking lever, connected with the armature of an electro-magnet.

This apparatus is sometimes called a Morse register.

The Morse recording or registering apparatus is shown in Fig. 468.

The paper fillet passes between a pair of rollers r, driven by the clockwork W. The upper roller is provided with a groove, so that the movement of the stylus at the bent end of the lever L, by the

electro-magnet M, moving its armature attached to the lever L, may indent or emboss the paper fillet. When no current is passing, the armature of the magnet and the lever L, are drawn back by the action of an adjustable spring at n.

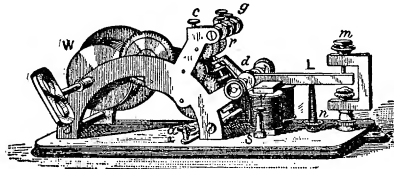

Fig. 468. Morse Recorder.

In the drawing, the ordinary Morse sounder is shown on the right. The sounder has almost entirely replaced the recording apparatus.

Recorder, Siphon — — An apparatus for recording in ink on a sheet of paper, by means of a fine glass siphon supported on a fine wire, the message received over a cable.

One end of the siphon dips in a vessel of ink. The record is received on a fillet of paper moved mechanically under the siphon. The ink is discharged from the siphon by electric charges imparted to the ink by a static electric machine.

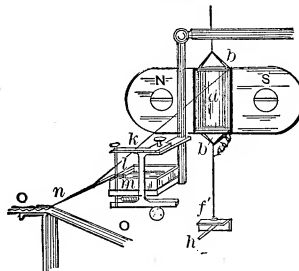
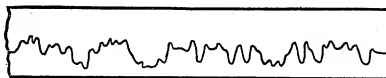

Fig. 469. The Siphon Recorder.

In the annexed sketch of the siphon recorder, Fig. 469, a light rectangular coil b b, of very fine wire, is suspended by a thin wire f f', between the poles N, S, of a powerful compound permanent magnet, and moving on the vertical axis of the supporting wire f f', and adjustable as to tension, at h. A stationary soft iron core a, is magnetized



SIPHON RECORDER

Fig. 470. Record of Siphon Recorder.

by induction and strengthens the magnetic field of N, S. The cable current is received by the

coil b b, through the suspending wire f f', and is moved by it to the right or the left, according to its direction, to an extent that depends on the current strength.

The fine glass siphon n, which dips into a reservoir of ink at m, is capable of movement on a vertical axis l, and is moved backwards or forwards, in one direction by a thread k, attached



Fig. 471. Record of Siphon Recorder.

to b, and in the opposite direction by a retractile spring attached to an arm of the axis l.

As the paper is moved under the point of the siphon, an irregular curved line is marked thereon.

Two records as actually received by a siphon recorder are shown in the Figs. 470 and 471. Movements upwards correspond to the dots, and downwards to dashes.

Rectification of Alcohol, Electric —
—(See *Alcohol, Electric Rectification of*.)

Rectified.—Turned in one and the same direction.

The alternate currents in a dynamo-electric machine are rectified or caused to flow in one and the same direction by means of a commutator.

The word commuted, generally used in this connection, would appear to be preferable to the word rectified. (See *Commutator*.)

Rectilinear Co-ordinates, Abseissa of —
—(See *Abseissa of Rectilinear Co-ordinates*.)

Rectilinear Current.—(See *Current, Rectilinear*.)

Red Heat.—(See *Heat, Red*.)

Red Hot.—(See *Hot, Red*.)

Reducteur or Resistance for Voltmeter.
—A coil of known resistance as compared with the resistance of the coils of a voltmeter, and connected with them in series for the purpose of increasing the range of the instrument. (See *Voltmeter*.)

Reducteur or Shunt for Ammeter.—A shunt coil connected in multiple with the coils of an ammeter for the purpose of changing the value of the readings.

The ratio of the resistance of the reducteur and the ammeter coils is known. A reducteur increases the range of current measured by the ammeter.

Refining of Metals, Electric — —The refining of metals by the application of electrolysis.

When certain precautions are taken, metals thrown down from their solutions, are obtained in a chemically pure condition. This fact is utilized in the electrical refining of metals. If, for example, a plate of impure copper is to be refined electrolytically, it is used as the anode of a copper bath, and placed opposite a thin plate of pure copper forming the cathode. The passage of the current gradually dissolves the copper from the plate at the anode, and deposits it in a chemically pure condition on the plate at the cathode.

Somewhat similar principles are employed for electrically refining other metals.

Reflect.—To throw off from a surface, according to the laws of reflection, as of waves in an elastic medium. (See *Reflection, Laws of*.)

Reflecting.—Throwing off from a surface, according to the laws of reflection. (See *Reflection, Laws of*.)

Reflecting Galvanometer.—(See *Galvanometer, Reflecting*.)

Reflection.—The throwing back of a body or wave from a surface at an angle equal to that at which it strikes such surface. (See *Reflection, Laws of*.)

Reflection, Laws of — —The laws governing the reflection of light

(1.) The angle of reflection, or the angle included between the reflected ray and the perpendicular to the reflecting surface at the point of incidence, is equal to the angle of incidence, or the angle included between the striking ray and the perpendicular to the reflecting surface at the point of incidence.

(2.) The plane of the angle of incidence coincides with the plane of the angle of reflection.

Reflection of Electro-Magnetic Waves.
—(See *Waves, Electro-Magnetic, Reflection of*.)

Reflection of Induction.—(See *Induction, Reflection of*.)

Reflector.—A plane or curved surface, capable of regularly reflecting light.

Reflector, Parabolic — —A reflector,

or mirror, the reflecting surface of which is a paraboloid, or such a surface as would be obtained by the revolution of a parabola about its axis.

A parabolic curve, which may be regarded as a section of a parabola, is shown in Fig. 472. A parabola has the following properties: If lines $F P$, $F P$, etc., be drawn from the point F , called the focus, to any point, P , P , etc., in the curve, and the lines $P p$, $P p$, etc., be then drawn severally parallel to the axis, $V M$, then all such angles, $F P p$, $F P p$, will be bisected by verticals to tangents at the point P , P , and P .

Therefore, if a light be placed at the focus of a parabolic reflector, all the light reflected from the surface of the parabola will pass off sensibly parallel to the axis $V M$.

In *Locomotive Head lights*, a lamp is placed at the focus of a parabolic reflector, and the parallel beam so obtained is utilized for the illumination of the track. In a *search light* an electric arc lamp is placed at the focus of a parabolic reflector, or at the focus of a lens.

A parabolic reflector is used for search lights, some-
times in connection with an arc lamp. A focusing arc lamp must be used for this purpose, so as to maintain the voltaic arc at the focus of the parabolic reflector, notwithstanding the unequal consumption of the positive and negative carbons. (See *Arc, Voltaic*.)

Refract.—To change the direction of waves in any elastic medium in accordance with the laws of refraction. (See *Refraction*.)

Refracting.—Changing the direction of waves in an elastic medium in accordance with the laws of refraction.

Refraction.—The bending of a ray of sound, light, heat, or electro-magnetism at the surface of any medium whose density differs from that through which such ray was previously passing.

Rays of sound, light, heat or electro-magnetism are transmitted or propagated in straight lines as long as the density of the homogeneous medium through which they are passing undergoes no change. That is, as long as the medium

is homogeneous or isotropic. (See *Medium, Isotropic*.) As the rays enter the surface of a medium which differs in density from that through which they have been passing, they are bent or refracted at the surface of such a medium.

This bending takes place towards a perpendicular to the refracting surface at the point of incidence, when the medium into which the rays are entering is of greater density than that they are leaving, and from the perpendicular when the medium they are entering is of less density than that they are leaving.

The refraction or bending of the ray is caused by the difference in the velocity with which the waves are propagated through the two media.

There is no refraction or deviation when the two rays enter the new medium at right angles to its surface, or when there is no angle of incidence.

Refraction, Double — —The property possessed by certain substances of splitting up a ray of light passed through them into two separate rays, and thus doubly refracting the ray.

Certain specimens of calc spar possess the property of double refraction. Each of the two rays into which the original ray is separated is polarized. Such calc spar is called doubly refracting calc spar.

Refraction, Double, Electric — —The property of doubly refracting light acquired by some transparent substances while in an electrostatic or electro-magnetic field.

Transient or momentary powers of double refraction, acquired by a transparent substance while placed in an electric field.

The intensity of double refraction is proportioned to the square of the electric force.

The action of an electric field in endowing a substance with the power of double refraction while kept in such field, is due to the strain produced by the electrostatic stress of the field.

A similar transient power of double refraction is acquired by many bodies when subjected to the strain produced by a simple mechanical stress.

Refreshing Action of Current.—(See *Action, Refreshing, of Current*.)

Region, Extra-Polar — —A term applied in electro-therapeutics to the region

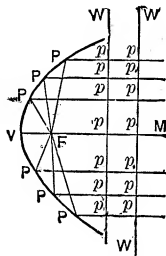

Fig. 472. Parabolic Reflector.

which lies outside or beyond the therapeutic electrode.

The term extra-polar region is used in contradistinction to polar region. (See *Region, Polar.*)

Region, Polar — —A term applied in electro-therapeutics to that region or part of the body which lies directly below the therapeutic electrode.

Register, Double-Pen Telegraphic — —A telegraphic register provided with two separate styluses or pens for recording the telegraphic message on a fillet of paper. (See *Register, Telegraphic.*)

Register, Morse — —A name sometimes given to a Morse recorder. (See *Recorder, Morse.*)

Register, Telegraphic — —An apparatus employed at the receiving end of a telegraphic line for the purpose of obtaining a permanent record of the telegraphic dispatch.

The telegraphic register consists essentially of means whereby a fillet or tape of paper is drawn mechanically under a pen or stylus attached to the armature of an electro-magnet and moving therewith.

The pen or stylus presses against the paper whenever the armature is attracted to the electro-magnet, and is held there while the cur-

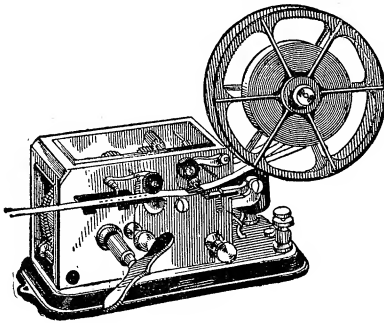

Fig. 473. Ink-Writing Register.

rent is passing through the coils of the electro-magnet. By these means the dots and dashes of the telegraphic alphabet are recorded on the paper fillet as embossed or printed dots and dashes. The Morse register is an apparatus of this description. (See *Recorder, Morse.*)

A form of ink-writing telegraphic register is shown in Fig. 473. It is self-starting.

Register, Time, for Railroads — —A telegraphic recording apparatus or register designed to record all telegraphic messages transmitted over a line.

The record is received on an endless band or fillet of paper. It is useful in case of disputes as to the time certain messages were sent over the line.

Register, Watchman's Electric — —A device for permanently recording the time of a watchman's visit to each of the different localities he is required to visit at stated intervals.

These registers are of a variety of forms. They consist, however, in general, of a drum or disc of paper driven by clockwork, on which a mark is made by a stylus or pencil, operated on the closing of a circuit by the pressing of a push button or the pressing of a key by the watchman at each station.

Registering Apparatus, Electric — — (See *Apparatus, Registering, Electric.*)

Registering Electrometer.—(See *Electrometer, Registering.*)

Regulable, Automatically — —Capable of being automatically regulated. (See *Regulation, Automatic.*)

Regulate, Automatically — —To regulate in an automatic manner. (See *Regulation, Automatic.*)

Regulation, Automatic — —Regulation automatically effected.

Regulation, Automatic, of Dynamo-Electric Machine — —Such a regulation of a dynamo-electric machine as will automatically preserve constant either the current or the potential difference.

The automatic regulation of dynamo-electric machines may be accomplished in the following ways, viz.:

(1.) *By a Compound Winding of the Machine.*

This method is particularly applicable to constant-potential machines. By this winding, the magnetizing effect of the shunt coils is maintained approximately constant, while that of the series coils varies proportionally to the load on the machine.

The series coils are sometimes wound close to

the poles of the machine, and the shunt coils nearer the yoke of the magnets. Custom, however, varies in this respect, and very generally the shunt coils are placed nearer the poles than the series coils. (See *Machine, Dynamo-Electric, Compound-Wound.*)

(2.) *By Shifting the Position of the Collecting Brushes.*

In the Thomson-Houston system of current regulation, the current is kept practically constant by the following devices: The collecting brushes are fixed to levers moved by the regulator magnet R, as shown in Fig. 474, the armature of which is provided with an opening for the entrance of the paraboloidal pole piece A. A dash-pot is provided to prevent too sudden movement.

When the current is normal, the coil of the regulator magnet is short-circuited by contact points at S T, which act as a shunt of very low resistance. These contact points are operated by the solenoid coils of the *controller*, traversed by the main current. The cores of this solenoid are suspended by a spring. When the current becomes too strong, the contact point is opened, and the current, traversing the coil of the regulator magnet A, attracts its armature, which shifts the collecting brushes into a position in which a smaller current is taken off.

A carbon shunt, r, of high resistance, is provided to lessen the spark at the contact points S T, which occurs on opening the circuit.

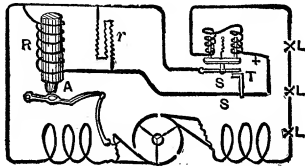

Fig. 474. Thomson-Houston Regulator.

In operation the contact points are continually opening and closing, thus maintaining a practically constant current in the external circuit.

(3.) *By the Automatic Variation of a Resistance shunting the field magnets of the machine,* as in the Brush system.

In Fig. 475 the variable resistance C, forms a part of the shunt circuit around the field magnets F M. This resistance is formed of a pile of carbon plates. On an increase of the current, such, for example, as would result from turning out some of the lamps, the electro-magnet B,

placed in the main circuit, attracts its armature A, and, compressing the pile of carbon plates C, lowers their resistance, thus diverting a proportionally larger portion of the current from the field magnet coils F M, and maintaining the current practically constant.

In some machines the same thing is done by hand, but this is objectionable, since it requires the presence of an attendant.

(4.) *By the Introduction of a Variable Resistance into the shunt circuit of the machine,* as in the Edison and other systems.

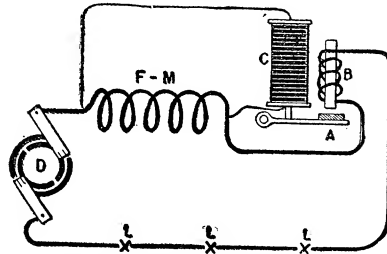

Fig. 475. The Brush Regulator.

This resistance may be adjusted either automatically by an electro-magnet whose coils are in an independent shunt across the mains, or may be operated by hand.

In Fig. 476, the variable resistance is shown at R, the lever switch being in this case operated by hand whenever the potential rises or falls below the proper value.

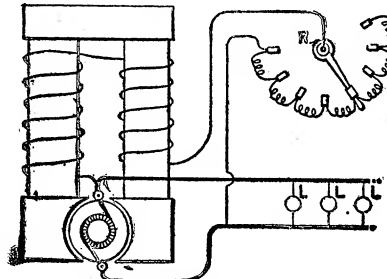

Fig. 476. The Edison Regulator.

The machine shown is thus enabled to maintain a *constant potential* on the leads to which the lamps L, L, L, etc., are connected in multiple arc.

(5.) *Dynamometric Governing,* in which a series dynamo is made to yield a constant current by governing the steam engine that drives it, by means of a dynamometric governor. This governor operates by maintaining a constant *torque* or turning moment, instead of by means of

the usual centrifugal governor which maintains a constant speed.

(6.) *Electric Governing of the Driving Engine*, in which the governor is regulated by the current itself instead of by the speed of rotation, as usual.

Regulation, Hand — — Such a regulation of a dynamo-electric machine as will preserve constant, either the current or the potential, said regulation being effected by hand as distinguished from automatic regulation.

Regulator, Automatic — — A device for securing automatic regulation as distinguished from hand regulation. (See *Regulation, Hand. Regulation, Automatic.*)

Regulator, Hand — — A resistance box, the separate coils or resistances of which can be readily placed in or removed from a circuit by means of a hand-moved switch.

The term hand regulator is used as distinguished from automatic regulator. (See *Regulator, Automatic. Regulation, Automatic.*)

Regulator Magnet.—(See *Magnet, Regulator.*)

Regulator, Monophotal Arc-Light — — A term sometimes employed for an electric arc lamp in which the whole current passes through the arc-regulating mechanism, and which is usually operated singly in circuit with a dynamo.

Regulator, Polyphotal Arc-Lamp — — A regulator for an arc lamp suitable for maintaining a number of lamps in series circuit with the dynamo.

Polyphotal regulators differ from monophotal regulators in that their regulating electro-magnets are energized by a shunt circuit around the electrodes of the lamp, while in monophotal regulators such electro-magnets are placed in the direct circuit. The terms monophotal and polyphotal are not generally used in America.

Reguline Electro-Metallurgical Deposit.—(See *Deposit, Electro-Metallurgical, Reguline.*)

Rejuvenation of Luminescence.—(See *Luminescence, Rejuvenation of.*)

Relative Calibration.—(See *Calibration, Relative.*)

Relay.—An electro-magnet, employed in systems of telegraphy, provided with contact points placed on a delicately supported armature, the movements of which throw a battery, called the local battery, into or out of the circuit of the receiving apparatus.

A relay is sometimes called a receiving magnet.

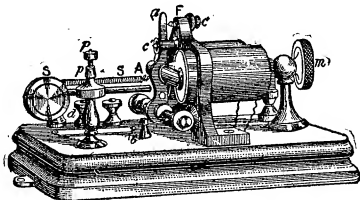

Fig. 477. Telegraphic Relay.

The use of a relay permits much smaller currents to be used than could otherwise be done, since the electric impulses, on reaching a distant station, are required to do no other work than attracting a delicately poised movable contact, and thus, by throwing a local battery into the circuit of the receiving apparatus, to cause such local battery to perform the work of registering. Its use is especially required in the Morse system of telegraphy in order to cause the sounder to be distinctly heard.

A form of relay that is much used is shown in Fig. 477.

The electro-magnet M, is wound with many turns of very fine wire. In the form used by the Western Union Telegraph Company, there are about 8,500 turns, having resistance of 150 ohms. A screw m, is provided for moving the electro-magnet M, a slight distance in or out, for the purposes of adjustment. A semi-cylindrical armature A, of soft iron, is attached to the insulated armature lever a, the lower end of which is supported by a steel arbor, which is pivoted between two set screws.

A retractile spring S', regulable at S, is provided for moving the armature away from the electro-magnet. There are four binding posts, two of which are placed in the circuit of the electro-magnet, and two in that of the local battery. The ends of the line wire are connected with the former, and the receiving instrument placed in the circuit of the latter. A platinum

contact is placed on the end of a screw supported at F, opposite a similar contact, near the end a, of the armature lever. The contact is regulable by means of a screw c.

On the energizing of the electro-magnet, the attraction of its armature closes the platinum contact, and, by thus completing the circuit of the local battery, causes an attraction of the armature of the receiving apparatus. On the cessation of the current in the main line, the spring S', pulls the armature away from the magnet, breaks the circuit of the local battery, and thus permits a similar spring on the receiving instrument to pull its armature away. Thus all the movements of the armature of the relay are reproduced with increased intensity by the armature of the receiving instrument.

The connections of the relay to the local battery and the registering apparatus, will be better understood from an inspection of Fig. 478, which represents a form of relay much used in Germany.

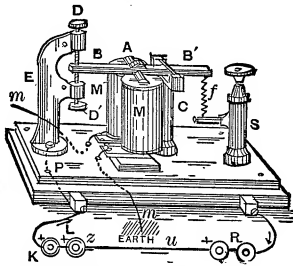

Fig. 478. Telegraphic Relay, German Pattern.

The retractile spring f, is regulated by the up-and-down movements of its lower support, which slides in the vertical pillar S. The line wire is shown at m m, connected at one end to earth by a ground wire.

The registering apparatus R, is connected in the circuit of the local battery L, as shown. The contacts are made by the end B, of the lever B B', attached to the armature A, of the electro-magnet M M.

Relay Bell.—(See *Bell, Relay, Electric.*)

Relay, Box-Sounding Telegraphic —
—A relay the magnet of which is surrounded by a resonant case of wood for the purpose of increasing the intensity of the sound made by the armature of the magnet.

A form of box-sounding relay is shown in Fig. 479.

Relay, Differential — —A telegraphic

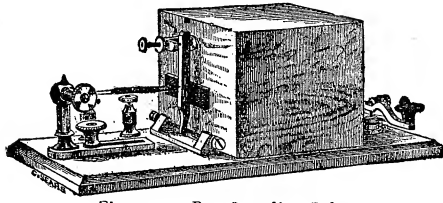

Fig. 479. Box-Sounding Relay

relay containing two differentially wound coils of wire on its magnet cores.

When the currents which pass through these two coils are of the same strength, there is no movement of the armature, since the fields of the two coils neutralize each other.

The differential relay is used in the differential method of duplex and quadruplex telegraphy. (See *Telegraphy, Duplex Differential Method of. Telegraphy, Quadruplex Differential Method of.*)

Relay Magnet.—A name sometimes given to a relay. (See *Relay.*)

Relay, Microphone — —A device for automatically repeating a telephonic message over another wire.

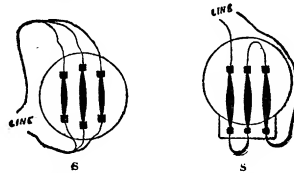

Fig. 480. Microphone Relay.

A form of microphone relay is shown in Figs. 480 and 481.

Several minute microphones mounted on the

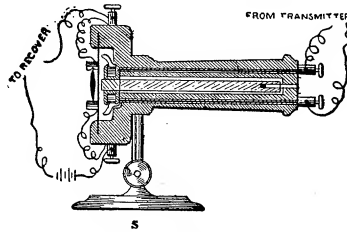

Fig. 481. Microphone Relay.

diaphragm of the telephone whose message is to be repeated, so vary the resistance of a local battery included in their circuit as to automatically repeat the articulate speech received.

The microphones may be connected either in

multiple arc or in series, as shown respectively to the left and right in Fig. 480.

Relay, Pocket Telegraphic — — A form of telegraphic relay of such small dimensions as to permit it to be readily carried in the pocket.

Relay, Polarized — — A telegraphic relay provided with a permanently magnetized armature in place of the soft iron armature of the ordinary instrument.

In the form of polarized relay shown in Fig. 482, N S, is a *steel magnet*, whose magnetism is consequently permanent, with its north and south poles at N, and S, respectively. The cores of the electro-magnet m, m', are of soft iron, and, since they rest on the north pole of the permanent steel magnet, the poles, brought very near together by the armatures at n, n', will be of the same polarity as N, *when no current is passing through the coils m, m'*; but when such current does pass, *one of these poles becomes of stronger north polarity, while the other changes its polarity to south.*

By these means to-and fro movements of the armature lever, with its contact point, are effected without the use of a retractile spring; movement in one direction occurring on the closing of the circuit due to the electro-magnetism developed

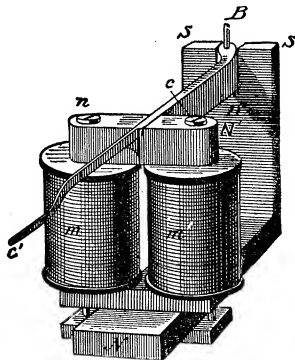

Fig. 482. Polarized Relay.

by the coils m, m', and movement in the opposite direction, on the losing of this magnetism on breaking the circuit, by the permanent magnetism of the steel magnet N S.

These movements are imparted to the soft iron lever c, c', pivoted at B, and passing between the closely approached soft iron poles at n, n'. This lever rests at the end c', against a contact point

when moved in one direction, and against an insulated point when moved in the opposite direction. It rests against the insulated point when no current is passing through the coils m, m'.

If the armature lever were placed in a position exactly midway between the poles n, and n', it would not move at all, being equally attracted by each; but if moved a little nearer one pole than the other, it would be attracted to, and rest against, the nearer pole.

When alternating currents are employed on the line, the lever c, c', must be adjusted as nearly as possible in the middle of the space between n and n', in which case it will remain on the side to which it was last attracted, until a current in the opposite direction moves it to the other side.

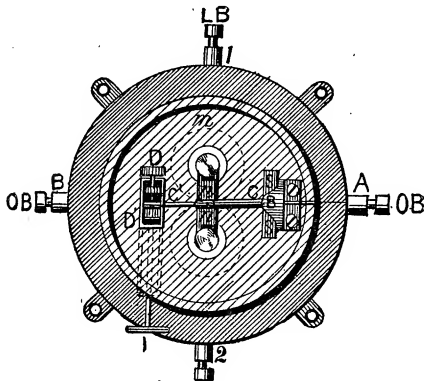

Fig. 483. A Detail of the Polarized Relay.

The space between the magnet poles n, n', and the contacts of the armature lever at D, and D', are shown in detail in Fig. 483, which is a plan of Fig. 482. The *binding posts* for the line battery are shown at L B, 1, and 2, and those for the local battery at A and B. The dotted lines show the connections.

Since the polarized relay dispenses with the retractile spring, it is far more sensitive than the ordinary instrument. Once adjusted, no further regulation is required, in which respect it differs very decidedly from non-polarized relays.

There are other forms of polarized relays, but the above will suffice to illustrate the general principle of their operation.

Relay Shunt, Stearn's — — (See *Shunt, Relay, Stearn's.*)

Reluctance, Magnetic — — A term recently proposed in place of magnetic resistance to express the resistance offered by a

medium to the passage through its mass of lines of magnetic force.

The term reluctance, in the sense of resistance to passage of lines of magnetic force, has been proposed in place of resistance, for the purpose of carrying out the conception of regarding the flow of lines of force in a magnetic circuit as being due to a magneto-motive force, and being opposed by a reluctance of the substances forming such circuit to the passage of such lines.

According to this conception,

The magnetic flux =

$$\frac{\text{The magneto-motive force}}{\text{The reluctance.}}$$

Reluctance, Magnetic, Unit of — —

Such a magnetic reluctance in a closed circuit that permits unit magnetic flux to traverse it under the action of unit magneto-motive force.

In present practical work reluctances vary from 100,000 to 100,000,000 of the practical units.

Reluctivity.—A term proposed for magnetic reluctance. (See *Reluctance, Magnetic.*)

This term is not generally adopted.

Removable Key Switch.—(See *Switch, Removable Key.*)

Renovation of Secondary Cell.—(See *Cell, Secondary or Storage, Renovation of.*)

Renovation of Secondary or Storage Cell.—(See *Cell, Secondary or Storage, Renovation of.*)

Reofore.—A rheophore. (See *Rheophore.*)

Repeaters, Telegraphic — Telegraphic devices, whereby the relay, sounder or registering apparatus, on the opening and closing of another circuit, with which it is suitably connected, is caused to repeat the signals received.

Repeaters are employed to establish direct communication between very distant stations, or to connect branch lines to the main line.

Fig. 484, shows Wood's Button Repeater. This repeater consists simply of a three-point switch L, capable of being placed on the points 1, 2 and 3; and a ground switch at 4. The circuits are arranged between the sounders S, S', relays

M, M', main batteries B, B', and the two main lines E, and W, in the manner shown.

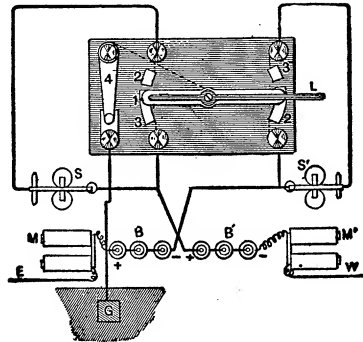

Fig. 484. Wood's Button Repeater.

If the lever L, is in the position shown in the drawing, the lines E and W, form independent circuits.

If the ground switch 4 is closed, and the lever L, is placed on 2, 2, the eastern line repeats into the western. If the lever L, is placed on the plates 3, 3, the western line repeats into the eastern.

This repeater is non-automatic and can be worked in but one direction at a time; moreover, it requires the services of an attendant.

The automatic repeater can be operated in both directions, and dispenses with the constant services of an attendant at the repeating station.

In sending a dispatch through a repeater, the dots and dashes are prolonged so as to give the lever of the repeating instrument time in which to move backward and forwards.

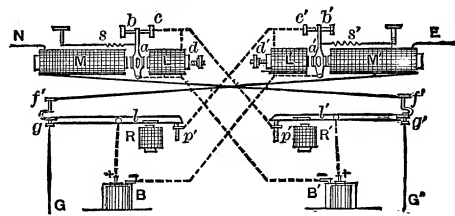

Fig. 485. Hick's Automatic Button Repeater.

In Hick's Automatic Repeater, shown in Fig. 485, the switch or circuit-changer is automatic in its action.

The relay magnets are shown at M, M', the sounders at R and R'; f, f', are platinum contacts operated by levers l and l', and L and L', are extra local magnets, that act on armatures

placed directly opposite the armatures of the relay magnets.

The extra local magnet L, is cut out of the circuit of B', the *extra local battery*, when the main circuit is broken, and the armature is in contact with c. As soon as this happens, however, the spring s, drawing away the armature, and thus opening the short-circuit of no resistance between c and a, establishes a circuit through L. On a, coming in contact with c, the circuit is again broken.

The tension of the spring s, is so regulated that a very rapid vibration of a, is maintained so constantly, that it is impossible to close the main circuit when L, is not cut out. The armature a, will therefore respond to very weak impulses of the relay magnet.

On breaking the *western main circuit* N, the lever a, vibrates very rapidly. The lever l, of the sounder R, first breaks the circuit of L, and afterwards that of the *eastern main circuit* E, which passes through M. Both L' and M', being broken, a slight tension of s', will hold a, in place, thus avoiding the breaking of the western main circuit through the closing of the local circuit through R. On the closing of the western circuit, the reverse of these operations occurs.

The author has taken the above explanation mainly from Pope's work on "Modern Practice of the Electric Telegraph."

Repeating Sounder.—(See *Sounder, Repeating*.)

Replenisher.—A static influence machine devised by Sir William Thomson for charging the quadrants of his quadrant electrometer.

Two brass carriers C and D, shown in Fig. 486, are electrically fixed to the end of the vulcanite rod E, which is capable of rotation by the thumb screw at M, in the direction shown by the arrow. Hollow metal half-cylinders, A and B, act as inductors, a strip of brass fixed around the edges of a piece of vulcanite P, connecting the metallic springs S, and S', as shown.

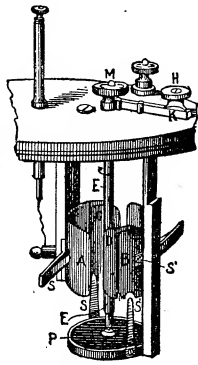

Fig. 486. The Replenisher.

The action of the replenisher is readily under-

stood from the following considerations, as suggested by Ayrton in his "Practical Electricity":

A and B, Fig. 487, are two insulated hollow metallic vessels having a small difference of potential between them, A being the higher. C, and D, are two small uncharged conductors held by insulating strings. If C and D, be held near A and B, as shown, the potential of C, will, by induction, be raised somewhat above that of D, so that when connected by a conductor, such as the metallic wire W, a small quantity of positive electricity will flow from C, to D, thus leaving D, positively, and C, negatively charged.

If, now, C and D, are removed from W, and placed in the bottom of B and A, as shown in Fig. 488, the difference of potential between A, and B, will be thereby increased, and if they are then withdrawn, and totally discharged, and

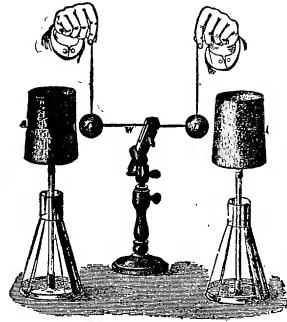

Fig. 487. Action of Replenisher.

again placed in the first position shown, an additional charge can be given to A and B, and this can be repeated as often as desired.

In the replenisher, A and B, correspond to the vessels A and B; the brass carriers C and D, to the balls C and D, and the spring S S, and M,

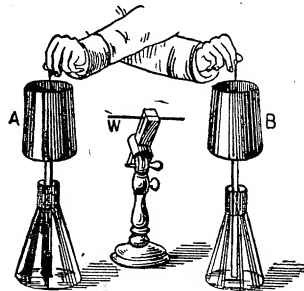

Fig. 488. Action of Replenisher.

to the wire W. No initial charge need be given to A and B, since they are invariably found to

be at a sufficient difference of potential to build up the charge.

Replenisher, Carriers of — —The moving conductors of a replenisher which carry the charges and thus permit of an accumulation of such charges. (See *Replenisher*.)

Repulsion, Electric — —The mutual driving apart or tendency to mutually drive apart existing between two similarly charged bodies, or the mutual driving apart of similar electric charges.

Repulsion, Electro-Dynamic — —The mutual repulsion between two electric circuits whose currents are flowing in opposite directions.

Parallel currents flowing in opposite directions repel one another, because their lines of magnetic force have the same direction in adjoining parts of the circuit. (See *Dynamics, Electro*.)

Repulsion, Electro-Magnetic — —The mutual repulsion produced by two similar electro-magnetic poles.

Repulsion, Electrostatic — —The mutual repulsion produced by two similar electric charges.

Repulsion, Magnetic — —The mutual repulsion exerted between two similar magnetic poles.

Repulsion, Molecular — —The mutual repulsion existing between molecules arising from their kinetic energy. (See *Matter, Kinetic Theory of*.)

Residual Atmosphere—(See *Atmosphere, Residual*.)

Residual Charge.—(See *Charge, Residual*.)

Residual Magnetism.—(See *Magnetism, Residual*.)

Resin.—A general term applied to a variety of dried juices of vegetable origin.

Resins are, in general, transparent, inflammable solids, soluble in alcohol, and, in general, excellent non-conductors of electricity. Rosin is one of the varieties of resin.

Resinous Electricity.—(See *Electricity, Resinous*.)

Resistance.—Something placed in a circuit for the purpose of opposing the passage or

flow of the current in the circuit or branches of the circuit in which it is placed.

The electrical resistance of a conductor is that quality of the conductor in virtue of which there is a fixed numerical ratio between the potential difference of the two opposing faces of a cubic unit of such conductor, and the quantity of electricity which traverses either face per second, assuming a steady flow to take place normal to these faces, and to be uniformly distributed over them, such flow taking place solely by an electromotive force outside the volume considered.

The term is used in the first definition in the concrete sense of something intended for or used as a resistance. For the physical definitions and facts see *Resistance, Electric*.

Gases offer very high resistance to the flow of an electric current. Their non-conducting power causes the increase of resistance which attends the polarization of a voltaic cell. (See *Cell, Voltaic, Polarization of*.)

Resistances consist of coils, strips, bars or spirals of metal, or plates of carbon, or metallic powders, powdered or granulated carbon, or liquids.

Resistance, Absolute Unit of — —The one thousand millionth of an ohm. (See *Ohm, Units, Practical*.)

Resistance, Assymmetrical — —Conductors or parts of conductors, which offer a greater resistance to the flow of an electric current in one direction than in another.

Assymmetrical conductors are unknown, so far as structural peculiarities are concerned, but can be obtained by the use of counter electromotive forces, acting as resistance. This term was proposed by Wilke in discussing the obtaining of continuous currents by commutatorless dynamo-electric machines.

The resistance of the human body is possibly an assymmetrical resistance.

An evident application of an assymmetrical resistance is to direct alternating currents so as to cause the current that passes to flow in and to the same direction.

Resistance, Balanced — —A resistance so placed in a circuit as to be balanced or made equal to another resistance connected therewith.

Resistance, Balanced, for Dynamos —
—A resistance that possesses a range sufficient to balance one dynamo against another with which it is desired to run in parallel. —(*Urquhart.*)

Resistance Box.—(See *Box Resistance.*)

Resistance Bridge.—(See *Bridge, Resistance.*)

Resistance Coil.—(See *Coil, Resistance.*)

Resistance Coil, Standard — —(See *Coil, Resistance, Standard.*)

Resistance, Conductivity — —The resistance offered by a substance to electric conduction, or to the passage of electricity through its mass.

Resistance, Dielectric — —A term sometimes employed for the resistance of a dielectric to mechanical strains produced by electrification.

The dielectric resistance of the glass, or other dielectric of a Leyden jar or condenser, is frequently overcome by the passage of the charges on the conducting surfaces, and the glass is thus pierced.

The term dielectric resistance would appear to be badly chosen; for, like all substances, dielectrics possess a true ohmic resistance, which increases with the increase of length, and decreases with the increase of area of cross-section.

The resistance of the dielectric, however, differs from the ordinary ohmic resistance of conductors, in that the resistance of the dielectric is suddenly overcome, and the discharge passes disruptively as a spark.

Resistance, Effect of Heat on Electric — —Nearly all metallic conductors have their electric resistance increased by an increase of temperature.

The carbon conductor of an incandescent electric lamp, on the contrary, has its resistance decreased when raised to electric incandescence. The decrease amounts to about three-eighths of its resistance when cold.

The effects of heat on electric resistance may be summarized as follows:

(1.) The electric resistance of metallic conductors increases as the temperature rises. In some alloys this increase is small.

(2.) The electric resistance of electrolytes decreases as the temperature rises.

(3.) The electric resistance of dielectrics and non-conductors decreases as the temperature rises.

RESISTANCE AND CONDUCTIVITY OF PURE COPPER AT DIFFERENT TEMPERATURES.

Centigrade Temperature	Resistance.	Conductivity.	Centigrade Temperature	Resistance.	Conductivity.
0°	1.00000	1.00000	16°	1.06168	.94190
1	1.00381	.99624	17	1.06563	.93841
2	1.00756	.99250	18	1.06959	.93494
3	1.01135	.98878	19	1.07356	.93148
4	1.01515	.98508	20	1.07742	.92814
5	1.01896	.98139	21	1.08164	.92452
6	1.02280	.97771	22	1.08553	.92121
7	1.02663	.97406	23	1.08954	.91782
8	1.03048	.97042	24	1.09365	.91445
9	1.03435	.96679	25	1.09763	.91110
10	1.03822	.96319	26	1.10161	.90776
11	1.04199	.95970	27	1.10567	.90443
12	1.04599	.95603	28	1.10972	.90113
13	1.04990	.95247	29	1.11382	.89784
14	1.05406	.94893	30	1.11782	.89457
15	1.05774	.94541			

—(*Latimer Clark.*)

Resistance, Electric — —The ratio between the electromotive force of a circuit and the current that passes therein.

The reciprocal of electrical conductivity.

Resistance can be defined as the reciprocal of electrical conductivity, because even the best electrical conductors possess appreciable resistance.

Ordinarily the resistance of a circuit may be conveniently regarded as that which *opposes* or *resists* the passage of the current. Strictly speaking, however, this is not true, since from *Ohm's law* (See *Law of Ohm, or Law of Current Strength*)

$$C = \frac{E}{R}, \text{ from which we obtain}$$

$$R = \frac{E}{C}, \text{ which shows that resistance is a}$$

ratio between the electromotive force that causes the current and the current so produced.

Resistance may be expressed as a velocity. The dimensions of resistance in terms of the electro-magnetic units are

$$\frac{L}{T}$$

(See *Units, Electro-Magnetic.*) But these are the dimensions of a velocity, which is the ratio of the distance passed over in unit time. Resistance may therefore be expressed as a velocity.

“The resistance known as ‘one ohm’ is intended to be 10^9 absolute electro-magnetic units, and, therefore, is represented by a velocity of 10^9 centimetres or 10,000,000 metres (one earth quadrant) per second.”—(*Sylvanus Thompson.*)

Resistance may be represented by a velocity, one ohm being the resistance of a wire, which, if moved through a unit field of force at the rate of 1,000,000,000 (10^9) centimetres per second will have a current of one ampere generated in it. (See *Resistance, Ohmic. Resistance, Spurious.*)

The true value of the ohm is exactly 10^9 centimetres. The material standards employed, *i. e.*, the B. A. and “legal” ohms, are not absolutely of this value.

One mil-foot of soft copper at 10.22 degrees C. or 50.4 degrees F. has the standard resistance of exactly 10 legal ohms; at 15.56 or 59.9 degrees F., it has a resistance of 10.20 legal ohms, and at 23.9 degrees C. or 75 degrees F., 10.53 legal ohms.

RESISTANCE.

Resistance of Wires of Pure Annealed Copper at 0° C. (Density = 8.9.)

Diameters in Millimetres.	Weight per Metre in Grammes.	Length in Metres per Kilogramme. (Bare Wire.)	Resistance of Wire of Pure Annealed Copper at 0 degree C.		
			Ohms per Kilometre.	Metres per Ohm.	Ohms per Kilogramme.
5	175	5.7	.8	1230.5	.00456
4.4	135.28	7.4	1.06	944.38	.00784
3.9	106.35	9.5	1.35	722	.0128
3.4	80.8	12.5	1.80	553.92	.0222
3	62.93	16	2.3	439.07	.0365
2.7	51	19.8	2.8	355.65	.0557
2.4	40.23	25	3.6	281	.088
2.2	33.82	29	4.2	236.08	.123
2	27.95	36	5.1	195.15	.185
1.8	22.7	44	6.3	153.08	.278
1.6	17.89	56	8	124.9	.448
1.5	15.75	63	9.1	109.75	.574
1.4	13.7	73	10.5	95.651	.763
1.3	11.84	85	12	82.42	1.03
1.2	10.06	100	14	70.247	1.42
1.1	8.47	119	17	59.024	2.02
1	6.99	144	20	48.782	2.95
.9	5.66	178	25	39.515	4.19
.8	4.47	225	32	31.225	7.21
.7	2.83	294	42	23.9	12.3
.6	2.52	400	57	17.56	22.78
.5	1.74	576	81	12.305	46.81
.4	1.175	902	122.4	8.173	110.41
.34	.808	1251	177.9	5.622	222.55
.3	.7181	1607	228.5	4.377	367.2
.24	.4026	2508	357	2.801	895.36
.2	.2797	3614	514	1.945	1,857.6
.16	.179	5590	803.1	1.245	4,489
.12	.1007	9929	1428	.7	14,179
.1	.0699	14369	2056	.486	29,549
.08	.0447	24570	3213	.311	78,943
.06	.0252	39824	5713	.173	227,515
.04	.0112	88878	12848	.078	1142,405

—(*Hospitalier.*)

The following table, based on Matthiessen’s measurements, gives the relative resistances of equal lengths and cross-sections of a number of different substances used in electricity as compared with silver.

LEGAL MICROHMS.

NAMES OF METAL.	Resistance in Microhms at 0 degree C.		Relative Resistance.
	Cubic Centimetre.	Cubic Inch.	
Silver, annealed...	1.504	0.5921	1.
Copper, annealed.	1.598	0.6292	1.063
Silver, hard drawn	1.634	0.6433	1.086
Copper, h’rd dr’wn	1.634	0.6433	1.086
Gold, annealed....	2.058	0.8102	1.369
Gold, hard drawn.	2.094	0.8247	1.393
Aluminium, ann’ld	2.912	1.147	1.935
Zinc, pressed.....	5.626	2.215	3.741
Platinum, annealed	9.057	3.565	6.022
Iron, annealed....	9.716	3.825	6.460
Nickel, annealed..	12.47	4.907	8.285
Tin, pressed.....	13.21	5.202	8.784
Lead, pressed.....	19.63	7.728	13.05
German silver.....	20.93	8.240	13.92
Antimony, pressed	35.50	13.88	23.60
Mercury.....	94.32	37.15	62.73
Bismuth, pressed..	131.2	51.65	87.23

—(*Ayrton.*)

The above resistances are for chemically pure substances only. Slight impurities produce a very considerable increase in the resistance.

Resistance, Electric, of Liquids — —

The resistance offered by a liquid mass to the passage of an electric current.

As a rule the electric resistances of liquids, with the single exception of mercury, are enormously higher than those of metallic bodies.

To roughly determine the resistance of a liquid, a section is taken between two parallel metallic plates A and B, Fig. 489, placed as shown in the figure, and an electric current is passed between them.

In order to accurately vary the size of the plates immersed in the liquid, and hence the area of cross-section of the liquid conductor, as well as the distance between the plates, the apparatus shown in Fig. 490 may be used, in

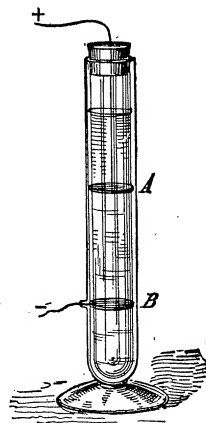

Fig. 489. Resistance of Liquid.

TABLE OF CONDUCTING POWERS AND RESISTANCES IN OHMS—B. A. UNITS.

NAMES OF METALS.	Conducting power at 0 degree C.	Resistance of a wire one foot long weighing one grain.	Resistance of a wire one metre long weighing one gramme.	Resistance of a wire one foot long $\frac{1}{1000}$ inch in diameter.	Resistance of a wire one metre long, one millimetre in diameter.	Approximate percentage of variation in resistance for 1 degree of temperature at 20 deg.
Silver, annealed.....	0.2214	0.1544	9.936	0.01937	0.377
Silver, hard drawn.....	100.00	0.2421	0.1689	9.151	0.02103
Copper, annealed.....	0.2064	0.1440	9.718	0.02057	0.388
Copper, hard drawn.....	99.55	0.2106	0.1469	9.040	0.02104
Gold, annealed.....	0.5849	0.4080	12.52	0.02650	0.355
Gold, hard drawn.....	77.96	0.5950	0.4150	12.74	0.02697
Aluminium, annealed.....	0.06822	0.05759	17.72	0.03751
Zinc, pressed.....	29.02	0.5710	0.3983	32.22	0.07244	0.365
Platinum, annealed.....	3.536	2.464	55.09	0.1166
Iron, annealed.....	16.81	1.2425	0.7522	59.40	0.1251
Nickel, annealed.....	13.11	1.0785	0.8666	75.78	0.1604
Tin, pressed.....	12.36	1.317	0.9184	80.36	0.1701	0.365
Lead, pressed.....	8.32	3.236	2.257	119.39	0.2527	0.387
Antimony, pressed.....	4.62	3.324	2.3295	216.0	0.4571	0.389
Bismuth, pressed.....	1.24	5.054	3.525	798.0	1.689	0.354
Mercury, liquid.....	18.740	13.071	600.0	1.270	0.072
Platinum-silver, alloy, hard or annealed.....	4.243	2.959	143.35	0.3140	0.031
German silver, hard or annealed.....	2.652	1.850	127.32	0.2695	0.044
Gold, silver, alloy, hard or annealed.....	2.391	1.668	66.10	0.1399	0.065

—(Fenkin.)

which these distances are readily adjustable, as shown.

Resistance, Equivalent — —A single resistance which may replace a number of separate resistances in a circuit without altering the value of the current traversing it.

Resistance, Essential — —A term sometimes used instead of internal resistance.

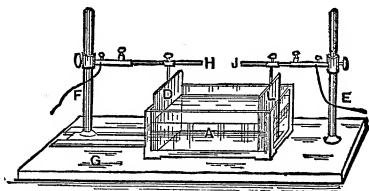

Fig. 490. Apparatus for Measuring Resistance of Liquid.

Resistance, External Secondary — —A term proposed by Du Bois Reymond for the change in the resistance of a circuit external to the electric source when cataphoric action takes place. (See *Action, Cataphoric*.)

“If the copper electrodes of a constant battery be placed in a vessel filled with a solution of cupric sulphate and from each electrode there projects a cushion saturated with this fluid, then,

on placing a piece of muscle, cartilage, vegetable tissue, or even a prismatic strip of coagulated albumen across these cushions, we observe, that very soon after the circuit is closed, there is a considerable variation of the current. * * * This phenomenon is called ‘external secondary resistance.’”—(*Landois and Sterling*.)

Resistance, Extraordinary — —A term sometimes employed instead of external resistance. (See *Resistance, External Secondary*.)

Resistance, False — —A resistance arising from a counter electromotive force and not directly from the dimensions of the circuit, or from its specific resistance.

The false resistance of any circuit is sometimes called its spurious resistance. (See *Force, Electromotive, Counter. Resistance, Spurious*.)

Resistance, Inductionless — —A term sometimes used instead of non-inductive resistance. (See *Resistance, Non-Inductive*.)

Resistance, Inductive — —A resistance which possesses self-induction.

Resistance, Insulation — —The resistance of a line or conductor existing between the line or conductor and the earth through the insulators, or between the two

wires of a cable through the insulating material separating them.

The insulation resistance of a telegraph line is the resistance that exists between the line and the earth, through its insulators. The insulation resistance will decrease as the length of line increases, since for any increase in the number of poles and insulators there is a proportional increase in the area of cross-section of the insulating supports.

If the insulation resistance is 1,000,000 ohms per mile, in a line 200 miles in length, the insulation resistance is only 5,000 ohms, that is, $\frac{1,000,000}{200} = 5,000$ ohms.

Resistance, Joint, of Parallel Circuits

— — The joint resistance of two parallel circuits is determined by means of the following formula :

$$R = \frac{r r'}{r + r'}$$

Where R = the joint resistance of any two circuits whose separate resistances are respectively r and r'.

When there are three resistances r, r' and r'', in parallel, the joint resistance,

$$R = \frac{r r' r''}{r r' + r r'' + r' r''}$$

(See *Circuits, Varieties of.*)

Resistance, Magnetic — — The reciprocal of magnetic permeability or conductivity for lines of magnetic force.

Resistance offered by a medium to the passage of the lines of magnetic force through it.

The magnetic resistance of the circuit of the lines of force is reduced by forming the circuit of a medium having a high magnetic permeability, such as soft iron. This is accomplished by the armature or keeper of a magnet, or by the iron in an iron-clad magnet. (See *Magnet, Iron-Clad.*)

Resistance, Measurement of — —

Methods employed for determining the resistance of any circuit or part of a circuit.

Numerous methods are employed for this purpose. Among these are :

- (1.) *The use of a resistance box with a Wheatstone bridge*, by opposing or balancing the unknown resistance against a known resistance. (See *Balance, Wheatstone's Electric.*)

- (2.) *The differential galvanometer.* (See *Galvanometer, Differential.*)

- (3.) *The method of substitution.*

- (4.) *Comparison of the deflections of a galvanometer.*

Method of Substitution.—A resistance-box R, Fig. 491, galvanometer G, and the resistance x, that is to be measured, are placed in the direct circuit of the battery B, by means of conductors of such thick wire that their resistance can be neglected.

The deflection of the galvanometer is first measured with x, in circuit, and no resistance in the box R. The resistance x, is then cut out of the circuit by placing a thick copper wire across the terminals of the mercury cups at m m', and resistances unplugged in R, until the same deflection is obtained. Then, if the electromotive force of the battery has remained constant, the resistances unplugged equal the unknown resistance.

For full description of the various methods of determining resistance the reader is referred to "Ayrton's Practical Electricity," "Kemp's Handbook of Testing," or other standard books on electrical measurements.

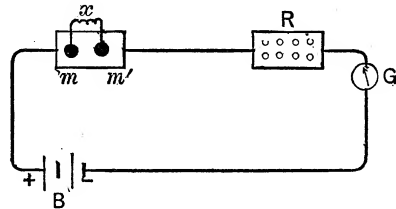

Fig. 491. Substitution Method.

When several resistances are placed in series in any circuit, by measuring the difference of potential at their terminals, their values can be determined by simple calculation, being directly proportional to these differences of potential.

This method is especially applicable to the measurement of such low resistances as the armatures of dynamo-electric machines.

Resistance, Non-Inductive — — A resistance in which self-induction is practically absent.

An incandescent lamp filament is practically a non-inductive resistance when compared with a coil on the helix of an electro-magnet.

Resistance of Human Body.—(See *Body, Human, Resistance of.*)

Resistance of Voltaic Arc.—(See *Arc, Voltaic, Resistance of*.)

Resistance, Ohmic — —The true resistance of a conductor due to its dimensions and specific conducting power, as distinguished from the spurious resistance produced by a counter electromotive force. (See *Force, Electromotive, Counter. Resistance, Spurious*.)

The term ohmic resistance must be regarded as a pleonasm. Its use can only be permitted in contradistinction to counter electromotive force resistance. True and spurious resistance would seem preferable.

Resistance or Cell, Selenium — —A mass of crystalline selenium, the resistance of which is reduced by placing it in the form of narrow strips between the edges of broad conducting plates of brass.

The selenium employed for this purpose is the vitreous variety which has been fused and maintained for several hours at about 220 degrees C., by means of which its resistance is reduced.

By exposure to sunlight, the resistance of a selenium cell is decreased fully one-half its resistance in the dark. The selenium cell is used in the photophone. (See *Photophone*.)

Resistance or Reducteur for Voltmeter. —(See *Reducteur or Resistance for Voltmeter*.)

Resistance, Secondary — —A term sometimes used in place of external secondary resistance. (See *Resistance, External Secondary*.)

Resistance Slide.—(See *Slide, Resistance*.)

Resistance, Specific — —The particular resistance which a substance offers to the passage of electricity through it.

In absolute measure, the resistance in absolute units between the opposite faces of a centimetre cube of the given substance.

In the practical system the resistance given in ohms.

Resistance, Specific Conduction — — A term sometimes used instead of specific resistance. (See *Resistance, Specific*.)

Resistance, Specific, of Liquids — —

The resistance of a given length (one centimetre) and area of cross-section (one square centimetre) of any liquid as compared with the resistance of an equal length and cross-section of pure silver.

The resistance of a few common liquids and solutions is here given from Lupton:

Water, pure, at 75 degrees C.	1.188 × 10 ⁸ ohms, <i>i. e.</i> , 118,800,000.
Water at 4 degrees C.	9.100 × 10 ⁶ “
Water at 11 degrees C.	3.400 × 10 ⁵ “
Dilute hydrogen sulphate (sulphuric acid) at 18 degrees C., 5 per cent. acid	4.88
Dilute hydrogen sulphate at 18 degrees C., 3 per cent. acid	1.38 ohms.
Nitric acid at 18 degrees C., density 1.32	1.61 “
Saturated solution of copper sulphate (blue vitriol) at 10 degrees C.	29.30 “
Saturated solution of zinc sulphate at 14 degrees C.	21.50 “
Hydrochloric acid, 20 per cent. acid, at 18 degrees C.	1.34 “
Sal ammoniac, 25 per cent. salt	2.53 “
Common salt, saturated, at 13 degrees C.	5.30 “

It will be observed that the resistance varies considerably with differences of temperature.

Resistance, Spurious — —A false resistance arising from the development of a counter electromotive force. (See *Resistance, False. Force, Electromotive, Counter*.)

The spurious resistance is also called the false resistance, in order to distinguish it from the true or ohmic resistance. (See *Resistance, Electric*.)

Resistance, Standard — —A resistance used for comparison with or the determination of unknown resistances.

A committee appointed by the American Institute of Electrical Engineers in 1890 reported the following values for the standard resistance of copper wire; at 0 degree C. in B. A. U. and legal ohms, viz.:

STANDARD RESISTANCE AT 0° C.

	B. A. U. Legal Ohms.	
"Meter-millimetre,"		
"soft copper"...	.02057	.02034
Cubic centimetre...	.000001616	.000001598
"Mil-foot"	9.720	9.612

Resistance, Tables of — Tables in which the resistance of equal lengths and cross-sections of different substances is given in ohms, or other units of resistance.

Resistance Thermometer.—(See *Thermometer, Electric Resistance.*)

Resistance, Transition — A term sometimes used in electro-therapeutics for a change in the value of the resistance caused by polarization.

Whenever an electric current passes through a fluid substance and decomposes the fluid, the decomposition products collect on the electrodes and produce an increase in the resistance of the circuit.

Resistance, True — The resistance which a conductor offers to the passage of a current by reason of its dimensions and specific conducting power, as distinguished from a spurious resistance produced by a counter electromotive force.

The true resistance is sometimes called the ohmic resistance.—(See *Resistance, Spurious Resistance, Ohmic.*)

Resistance, Unit of — Such a resistance that unit difference of potential is required to cause a current of unit strength to pass. (See *Ohm. Potential, Electric. Potential, Difference of.*)

Resistance, Unit of, Absolute — The one thousand millionth of an ohm. (See *Ohm. Units, Practical.*)

Resistance, Unit of, Jacobi's — The electric resistance of 25 feet of a certain copper wire weighing 345 grains.

Another unit of electric resistance proposed by Jacobi was the resistance of a copper wire one metre in length and one millimetre in diameter.

Resistance, Unit of, Matthiessen's — The resistance of one statute mile of pure annealed copper wire $\frac{1}{16}$ inch in diameter at

15.5 degrees C, and determined by him to be 13.59 B. A. ohms.

Resistance, Unit of, Varley's — The resistance of one statute mile of a special copper wire $\frac{1}{16}$ inch in diameter.

Varley's unit was afterwards adjusted by him to equal 25 Siemens Mercury Units.

Resistance, Variable — A resistance the value of which can be readily varied.

Variable resistances are either :

- (1.) Automatically variable resistances; or
- (2.) Non-automatically variable resistances.

Resistance, Variable, Automatic — A resistance the value of which can be automatically varied.

A pile of carbon plates resting on one another, in loose contact, offers a high resistance, but when compressed as by an electro-magnet their resistance is lowered. Brush employs such an automatic resistance in the regulation of his dynamo-electric machine. (See *Regulation, Automatic.*)

Resistance, Variable Non-Automatic — A resistance the value of which is regulated by hand. (See *Rheostat.*)

Resistance, Virtual — A term sometimes employed instead of impedance. (See *Impedance.*)

Resonance, Electric — The setting up of electric pulses in open-circuited conductors, by the action of pulses in neighboring conductors.

Electric resonance, like acoustic resonance, takes place when a correspondence exists between the time-rate of vibration of the body producing the resonance, and the body in which the resonance is produced. In other words, when the wave lengths are the same in the two bodies, or when the wave length in one is equal to a half wave length, or some definite multiple of a half wave length of the other.

Partial resonance may occur, when there is a small difference between the wave lengths of the two bodies. Beyond certain limits, however, this is so small as to be practically absent.

When an electrical pulse is started in a conductor by the discharge of a Leyden jar, a side flash spark is obtained in the alternative path, between the discharge points. The length of this spark has its greatest value, when the time required for the

pulse to travel backwards and forwards along the conducting wires, is exactly equal to the time of a complete oscillation in the circuit, or when the length of the open-circuit wires is equal to half a wave length, or some multiple of half a wave length.

The fact that the length of the spark is greatest when certain relations exist between the dimensions of the two circuits, shows that the time-rate of an electrical pulse in any circuit depends on the dimensions of that circuit.

In the case of acoustic resonance, in order that one tuning fork may be able to excite vibrations in another, the fork producing or exciting the vibration must be strictly in unison with the fork in which the vibrations are excited, and any variations produced in the rate of vibration of the sounding fork, by overloading it, or, in other words, by altering its dimensions, checks the effects of its resonance.

In a similar manner, any alterations in the dimensions of the circuit, checks or diminishes the effects of electric resonance in a neighboring circuit, which was previously in unison with it. This has been experimentally shown by Hertz as follows:

An induction coil A, Fig. 492, has the terminals of its secondary connected to an open rectangular circuit provided with sparking terminals, 1, and 2, called a spark micrometer. Under certain conditions, when the discharge occurs at the terminals B, sparks are produced by electric resonance in the electric resonator formed by the spark micrometer at M.

Supposing, now, that a certain character of spark is obtained at the terminals B, that is, a certain velocity of electrical pulsations is obtained which depends on the nature of the spark; suppose, moreover, that the dimensions of the spark micrometer or electric resonator are such that the greatest length of spark is obtained. Then, any alteration in the character of these sparks, between the terminals at B, varies the intensity of the sparks in the spark micrometer.

If, for example, the apparatus be arranged

as shown in Fig. 493, in which one of the secondary terminals of the induction coil has connected with it a copper wire *ig h*. The sparks at M, decrease considerably. When, however, the conductor C, is connected with the free end H, of this additional conductor, then this effect is not observed, as is shown by the fact that when the conductor C, is attached at the point G, it produces no effect on it.

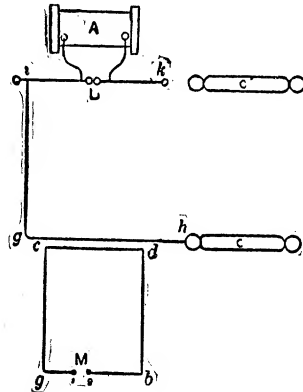

Fig. 493. Electric Resonance.

In another experiment with the same apparatus, matters may be arranged that the sparks in the micrometer circuit pass singly. When, now, another conductor C', is attached to K, a stream of sparks immediately passes.

It would appear, therefore, from the above experiments, that when two circuits are taken, having as nearly as possible the same vibration periods, any alteration in the dimensions of either will prevent one from producing electrical resonance in the other.

In the above experiments Hertz demonstrated the following facts, viz.,

(1.) The sparks in the micrometer circuit are smaller when the discharges take place between points, or a point and a plate, instead of between knobs.

(2.) The micrometer sparks are feebler in rarefied gas than in air at ordinary pressures.

(3.) Extremely slight differences in the nature of secondary sparks produce considerable difference in the length of the micrometer sparks.

Hertz found the above results were obtained when the secondary sparks were of a brilliant color, and were attended by a sharp crack.

(4.) The length of the spark in the micrometer

circuit varies with the length of the micrometer circuit.

This, of course, follows from the fact that any alteration of the length in the micrometer circuit, produces, by electrical retardation, a corresponding alteration in the time of the electrical pulses.

(5.) No effect is produced in the length of the micrometer spark by variations in the material, the resistance, or the diameter of the wire forming the micrometer circuit.

This is probably because the rate of propagation of electrical pulses along a conductor, depends mainly on the capacity of the conductor, and on its co-efficient of self-induction, and only to a slight extent on its resistance.

(6.) The length of wire connecting the micrometer circuit with the secondary circuit has but little effect, provided such length does not exceed a few metres.

Local disturbances, therefore, must traverse conductors without undergoing any appreciable change.

(7.) The position of the point on the micrometer circuit connected with the secondary circuit, is of the greatest importance.

When the point on the micrometer circuit is situated symmetrically with respect to the two micrometer knobs, variations of potential will reach the terminals in the same phase, and there will be but little effect, as seen by the sparks between the micrometer knobs. Such a point on the micrometer knobs is called the null point, or it is called as in a corresponding case in acoustics, a nodal point. (See *Point, Null. Point, Nodal.*)

(8.) When the conductors are of sufficient length, their approach produces disturbances in a previously adjusted and quiet spark micrometer, just as the approach of a conductor would.

Probably one of the most curious effects connected with the phenomena of electrical resonance is that pointed out by Lodge, viz.: that when the spark from a secondary circuit is so placed that the light is visible from a micrometer circuit, the effects of the discharge are greatly increased. Lodge also found that the light from burning magnesium wire, or, in general, light rich in the ultra-violet rays, produces the same effect.

Resonator, Electric — — An apparatus employed by Hertz in his investigations on electric resonance. (See *Résonance, Electric.*)

An electric resonator consists essentially of an

open-circuited conductor, or circuit of such dimensions that electro-magnetic waves or pulses are propagated through it at the same rate as those which are occurring in a neighboring circuit from which electro-magnetic radiation is taking place. Under these circumstances electro-magnetic pulses are set up sympathetically by resonance in the open circuit of the resonator, like the sympathetic vibrations in a tuning fork, when placed near another vibrating tuning fork, which is giving off sound waves of exactly the same period of vibration as its own.

Resonator, Electro-Magnetic — — A term applied to the Hertz spark micrometer, in which electro-magnetic waves are produced by electric resonance. (See *Resonance, Electric.*)

Resultant.—In mechanics, a single force that represents in direction and intensity the effects of two or more separate forces.

The separate forces are called the components. (See *Components.*)

Retardation.—A decrease in the speed of telegraphic signaling caused either by the induction of the line conductor on itself, or by mutual induction between it and neighboring conductors, or by condenser action, or by all.

The line must receive a certain charge before a current sent into it at one end can produce a signal at the other end. This charge will depend on the length and surface of the wire, on the neighborhood of the wire to the earth or other wires, and on the nature of the insulating material between the wire and neighboring conductors. This results in a charge given to the wire which is lost as a current for signaling. The greater the *electrostatic capacity* of the line wire, the greater will be the retardation in signaling. (See *Capacity, Specific Inductive. Dielectric. Capacity, Electrostatic. Induction, Electro-Dynamic.*)

Retardation in signaling is produced by the following causes:

(1.) *Self-Induction* which produces extra currents. (See *Induction, Self. Currents, Extra.*)

The extra current on making, retards the beginning of the signal; the extra current on breaking, retards its stopping.

(2.) *Mutual Induction* between the line conductor and neighboring conductors.

(3.) The *Magnetic Inertia* or *Lag*, or the time required to magnetize or demagnetize the core of the electro-magnetic receptive devices used on the line.

(4.) By *Condenser Action*, the cable acting as a condenser.

Retardation, Electric — —A retardation in the starting or stopping of an electric current, arising from self-induction. (See *Induction, Self. Retardation.*)

Retardation, Inductive — —A retardation in the appearance of a signal at the distant end of a cable, produced by the action of induction. (See *Retardation.*)

Retardation, Magnetic — —A retardation in the magnetization or demagnetization of a substance due to magnetic lag. (See *Retardation. Lag, Magnetic.*)

Retarding, Electrically — —Decreasing the speed of telegraphic signaling, by means of induction. (See *Retardation.*)

Retentivity, Magnetic — —A term proposed by Lamont in place of coercive force, or the power possessed by a magnetizable substance of resisting magnetization or demagnetization. (See *Force, Coercive.*)

Return Circuit.—(See *Circuit, Return.*)

Return, Earth — —(See *Earth Return.*)

Return Ground.—(See *Ground-Return.*)

Return Wire or Conductor.—(See *Wire, Return.*)

Returns.—In a system of distribution, those conductors through which the current flows back from the electro-receptive devices to the source. (See *Leads.*)

The word returns is sometimes used in a system of distribution by parallel circuits, to distinguish between the conductor by which the current goes back or returns from the receptive devices to the dynamo, and the conductor that leads it to the receptive devices. The term leads is, however, often applied to both conductors.

Reverse-Induced Current.—(See *Current, Reverse-Induced.*)

Reversed Currents.—(See *Currents, Reversed.*)

Reverser, Current — —A switch, or other apparatus, designed to reverse the direction of a current.

Reversible Bridge.—(See *Bridge, Reversible.*)

Reversible Heat.—(See *Heat, Reversible.*)

Reversibility of Dynamo.—The ability of a dynamo to operate as a motor when traversed by an electric current. (See *Motor, Electric.*)

Reversing Gear of Electric Motor.—(See *Motor, Electric, Reversing Gear of.*)

Reversing Key.—(See *Key, Reversing.*)

Reversing Key of Quadruplex Telegraphic System.—(See *Key, Reversing, of Quadruplex Telegraphic System.*)

Reversing Magnetic Field.—(See *Field, Magnetic, Reversing.*)

Rheochord.—A word formerly employed instead of rheostat. (See *Rheostat.*)

Rheometer.—A word formerly employed for any device for measuring the strength of a current.

This word is now obsolete and is replaced by the word galvanometer. (See *Galvanometer.*)

Rheomotor.—A word formerly employed to designate any electric source.

This word is now obsolete, and replaced by the various names of the different electric sources. (See *Source, Electric.*)

Rheophore.—A word formerly employed to indicate a portion of a circuit conveying a current and capable of deflecting a magnetic needle placed near it. (Obsolete.)

Rheoscope.—A word formerly employed in place of the present word galvanoscope, for an instrument intended to show the presence of a current, or its direction, but not to measure its strength. (Obsolete.)

Rheoscope, Physiological — —A sensitive nerve-muscle preparation employed to determine the presence of an electric current. (See *Frog, Galvanoscope.*)

A term sometimes applied in electro-therapeutics to the frog's legs preparation adapted to show the presence of any electric current.

The physiological rheoscope is adapted to show the presence of an electric current without the use of a galvanometer. On the passage of the electric current the frog's legs twitch convulsively.

Rheostat.—An adjustable resistance.

A rheostat enables the current to be brought to a standard, *i. e.*, to a fixed value, by adjusting the resistance; hence the name.

The term rheostat is applied generally to a readily variable resistance, the varying values of which are known.

Rheostat, Dynamo-Balancing — —An adjustable resistance whose range is sufficient to balance the current of one dynamo against another with which it is required to run in parallel.

Rheostat, Water — —A rheostat the resistance of which is obtained by means of a mass of water of fixed dimensions. (See *Rheostat*.)

Rheostat, Wheatstone's — —A form of apparatus sometimes employed for an adjustable resistance.

This apparatus is very seldom employed in accurate work.

The parallel cylinders A and B, Fig. 494, are formed respectively of conducting and non-conducting materials, the bare wire on which can be wound from either cylinder to the other.

When introduced into a circuit, only the resistance of that part of the wire that is on B, is introduced into the circuit, since the bare wire on A, is short-circuited by the metallic cylinder.

This rheostat is not very suitable for accurate measurements, owing to the difficulty of invariably obtaining reliable contacts.

Rheostatic Machine.—(See *Machine, Rheostatic*.)

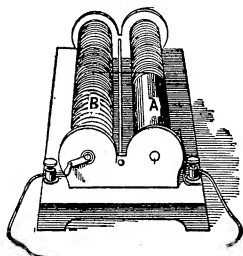

Fig. 494. Wheatstone's Rheostat.

Rheotome.—A word formerly employed for any device by means of which a circuit could be periodically interrupted.

This word is now obsolete, and is replaced by *interrupter*. (See *Interrupter*.)

Rheotrope.—A word formerly employed for any device by which the current could be reversed.

This word is now obsolete and replaced by *commutator* or *current reverser*. (See *Reverser, Current*.)

Rhigolene.—A highly volatile hydro-carbon obtained during the distillation of coal oil, and employed in the flashing treatment of carbons for incandescent lamps. (See *Carbons, Flashing Process for*.)

Rhumbs of Compass.—(See *Compass, Rhumbs of*.)

Ribbed Armature Core.—(See *Core, Armature, Ribbed*.)

Ribbon Copper.—(See *Copper, Ribbon*.)

Right-Handed Solenoid.—(See *Solenoid, Right-Handed*.)

Right-Hand Trolley Frog.—(See *Frog, Trolley, Right-Hand*.)

Rigidity, Molecular — —Resistance offered by the molecules of a substance to rotation or displacement.

The molecular rigidity of a magnetizable substance was until recently considered to be the cause of the differences of coercive force or magnetic retentivity possessed by different substances. The general acceptance of Ewing's theory of magnetism has, of course, caused the above view to be considerably modified. (See *Magnetism, Ewing's Theory of. Force, Coercive. Retentivity, Magnetic*.)

Ring, Ampère — —The turn or turns of wire used in electric balances for the measurement of electric current.

Ring Armature.—(See *Armature, Ring*.)

Ring Armature Core.—(See *Core, Armature, of Dynamo-Electric Machine*.)

Rings, Electric — —A term sometimes used instead of Nobili's rings. (See *Metallochromes*.)

Rings, Electro-Chromic — — A term sometimes applied to metallochromes. (See *Metallochromes*.)

Rings, Nobili's — — A term sometimes used for metallochromes. (See *Metallochromes*.)

Roaring of Arc.—(See *Arc, Roaring of*.)

Rocker Arm.—(See *Arm, Rocker*.)

Rocker, Brush — — In a dynamo-electric machine or electric motor, any device for shifting the position of the brushes on the commutator cylinder.

Rocker, Multiple-Pair Brush — — A term sometimes used for multiple-pair brush yoke. (See *Yoke, Multiple-Pair Brush*.)

Rocker, Single-Brush — — A device by means of which a single pair of brushes are so supported on a dynamo-electric machine or electric motor, as to be capable of being readily shifted into the desired position on the commutator cylinder.

Rocker, Single-Pair Brush — — A term sometimes used for single-pair brush yoke. (See *Yoke, Single-Pair Brush*.)

Rod Clamp.—(See *Clamp, Rod*.)

Rod, Clutch — — A clutch or clamp provided in an arc lamp to seize the lamp rod and thus arrest its fall, during feeding, beyond a certain predetermined point.

The clutch or clamp is caused to release or hold the lamp rod by the action of an electro-magnet placed in a shunt circuit around the electrodes. (See *Lamp, Arc, Electric*.)

Rod, Discharging — — A jointed rod provided at both ends with balls and connected at the middle by a swinging joint which permits the balls to move towards or from one another, employed for the disruptive discharge of Leyden batteries or condensers. (See *Discharge, Disruptive, Jar, Leyden*.)

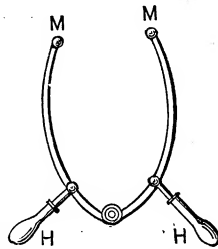

Fig. 495. Discharging Rod.

The insulated handles H, H, Fig. 495, permit

the balls at M, M, to be readily applied to the opposite coatings of the jar or condenser.

The name discharging tongs is sometimes applied to this apparatus.

Rod, Lamp — — A metallic rod provided in electric arc lamps for holding the carbon electrodes.

When the upper carbon only is fed, as is the case in most arc lamps, there is usually but one lamp rod provided. The clutch or clamp of the feeding device acts against this rod, which must of necessity be at least as long as the upper carbon. (See *Lamp, Arc, Electric*.)

Rod, Lightning — — A rod, or wire cable of good conducting material, placed on the outside of a house or other structure, in order to protect it from the effects of a lightning discharge.

Lightning rods were invented by Franklin. The results of a very extended inquiry on the subject, leave no room for doubt that a lightning rod, properly placed and constructed, affords an efficient protection to the buildings on which it is placed.

To insure this protection, however, the following conditions were, until very recently, generally insisted on in order to permit the rod to properly act, viz.:

(1.) The rod, generally of iron or copper, should have such an area of cross-section as to enable it to carry without fusion the heaviest bolt it is liable to receive in the latitude in which it is located.

When of iron, the area of cross-section should be about seven times greater than when of copper.

(2.) The rod should be continuous throughout, all joints being carefully avoided.

When joints are used, they should be made of as low resistance as possible, and should be protected against corrosion.

(3.) The upper extremity of the rod should terminate in one or more points formed of some metal that is not readily corroded, such as platinum or nickel.

(4.) The lower end of the rod should be carried down into the earth until it meets permanently damp or moist ground, where it should be attached to a fairly extended metallic surface buried in the ground.

Metallic plates will answer for grounding the

rod, but, if gas or water pipes are available, the rod should be placed in good electrical connection therewith, by wrapping it around and soldering it to such pipes.

This fourth requirement is of great importance to the proper action of a lightning rod, and unless thoroughly fulfilled, may render the rod worthless, no matter how carefully the other requirements are attended to. When a bolt strikes a lightning rod which is not properly grounded, the discharge is almost certain to destroy the building to which the rod is connected.

(5.) The rod should not be insulated from the building, unless to prevent stains from the oxidation of the metal. On the contrary, the rod should be directly connected with all masses of metal in its path, such as tin roofs, gutter spouts, metallic cornices, etc. In this way only can dangerous disruptive lateral discharges from the rod to such masses of metal be avoided.

(6.) The rod should project above the roof or highest part of the building, or, in other words, the height of the rod should bear a certain proportion to the size of the building to be protected.

A rod will protect a conical space around it, the radius of whose base is equal to the vertical height of the rod above the ground, but whose sides are curved inwards instead of being straight. Where the building is very high, a number of separate rods *all connected to one another* should be employed.

A lightning rod sometimes fails to protect a house or barn, from the fact that a heated, ascending current of air from a fire in the house, or from the gradual heating of green hay or grain in the barn, acting as a conductor, increases the virtual height of the house beyond the ability of its rods to protect it.

(7.) A stranded conductor is much better than an equal cross-section of a solid rod of the same metal.

A copper tape is better than a copper rod for lightning rods, because a rapidly periodic current, whose periodicity is sufficiently great, passes practically over the surface of the conductor only. Considering an electric current as taking its energy from the surrounding dielectric, a tape is better, because the surface which absorbs the energy is greater in the case of a tape than of a solid rod. (See *Law, Poynting's*.)

A lightning rod more frequently acts to quietly discharge an impending cloud by *convective dis-*

charge than by an actual *disruptive discharge* of the same. (See *Discharge, Convective. Discharge, Disruptive.*)

Lightning rods should be frequently tested to see that no breaks or oxidation of their joints have occurred.

Professor Lodge takes exception to some of the heretofore generally received notions concerning the action of lightning rods. He distinguishes between two distinct kinds of discharge that may occur between a charged cloud and the earth, viz.:

(1.) A steady strain or current.

(2.) An impulsive rush or oscillatory discharge.

A discharge by a steady strain or current occurs when the cloud gradually approaches a point on the earth; or, in the case of the cloud being stationary, when it receives its charge gradually by the approach of another cloud.

In steady discharge, the lightning rod, with its pointed end, either quietly discharges the cloud by a convective discharge, or by a harmless conductive discharge through the rod, after a spark has passed disruptively between the cloud and the rod. (See *Discharge, Convective. Discharge, Conductive. Discharge, Disruptive.*)

The impulsive discharge or rush occurs whenever the cloud that discharges to the earth receives its charge suddenly, as by the discharge into it of a neighboring cloud, or when a bound charge, produced by the presence of a neighboring charged cloud, is suddenly liberated by discharge, and, thus becoming free, impulsively discharges to the earth.

In all cases of an impulsive discharge or rush, a counter electromotive force is set up in the rod, which resists the discharge through the rod and causes the electricity to rush back and spit off in lateral discharges. In this case the conducting power of the rod has no effect in facilitating the discharge. Indeed, the smaller its resistance, and the longer the oscillations last, the greater the danger from lateral discharges. (See *Discharge, Lateral. Path, Alternative.*)

The following principles advanced by Lodge differ from the views heretofore generally received, viz.:

(1.) Iron is a better substance for a lightning rod than copper, because it is equally as good a conductor as copper for very rapidly alternating currents, and is more difficult to fuse.

(2.) All neighboring metallic conductors should be connected to earth. These connections should

preferably be by separate conductors rather than by the rod itself.

(3.) The lightning conductors should have a good separate earth, but should be connected to water pipes, gas pipes, etc., if near them, by an underground connection.

(4.) The lightning conductor should be detached from the building and not close against it.

(5.) The rod should be of flat section, or a stranded conductor.

Rod, Lightning, for Ships — —A system of rods designed to afford electric protection for vessels at sea.

Since the lightning discharge takes place between the points of greatest difference of potential, and these points are generally the cloud and the nearest point of the earth, tall objects are especially liable to be struck.

Ships at sea should, therefore, be thoroughly protected from lightning.

In Harris' system of lightning protection for ships, the rods are connected with a series of copper plates and rods so placed on the masts as to readily yield to strains. These plates or rods are electrically connected with the copper sheathing of the vessel and *with all large masses of metal* in the vessel. This latter precaution is especially necessary in the case of men-of-war, in order to protect the powder magazine.

Harris' method for the lightning protection of ships was adopted only after very considerable opposition. It proved, however, so efficacious in practice that serious effects of lightning on vessels so protected are now almost unknown. In 1845, Harris received the honor of knighthood from the English Government for his services in this respect.

Rod, Lightning, Points on — —Points of inoxidizable material, placed on lightning rods, to effect the quiet discharge of a cloud by convection streams. (See *Rod, Lightning. Convection, Electric.*)

Rod, Thunder — —A term formerly used for lightning rod. (See *Rod, Lightning.*)

Rods, Bus — —Heavy copper rods employed in a central or distributing station, to which all the terminals of the generating dynamos are connected, and from which the current passes to the different points of the distribution system over the feeders.

Bus rods are often called bus bars or bus wires. (See *Wires, Bus.*)

Rodding a Conduit.—(See *Conduit, Rodding a.*)

Rolling Contact.—(See *Contact, Rolling.*)

Rose, Ceiling — —An ornamental ceiling plate through which an electric conductor passes.

Rosette.—An ornamental plate provided with contacts connected to the terminals of the service wires, and placed in a wall for the ready attachment of the incandescent lamp.

A word sometimes used in place of rose.

Rosette Cut-Out.—(See *Cut-Out, Rosette.*)

Rotary Magnetic Polarization.—(See *Polarization, Magnetic Rotary.*)

Rotary-Phase Current.—(See *Current, Rotating.*)

Rotary-Phase Dynamo.—(See *Dynamo, Rotary-Phase.*)

Rotary-Phase Motor.—(See *Motor, Rotating Current.*)

Rotary-Phase Transformer.—(See *Transformer, Rotary-Phase.*)

Rotating Brushes of Dynamo-Electric Machine.—(See *Brushes, Rotating, of Dynamo-Electric Machines.*)

Rotating Current.—(See *Current, Rotating.*)

Rotating Current Field.—(See *Field, Rotating Current.*)

Rotating Current Motor.—(See *Motor, Rotating Current.*)

Rotating Current Transformer.—(See *Transformer, Rotatory Current.*)

Rotation, Electro-Magnetic — —A rotation obtained by electro-magnetic attractions and repulsions. (See *Disc, Arago's. Disc, Faraday's. Motor, Electric.*)

Rotation, Magneto-Optic — —A rotation of the plane of polarization of a beam of polarized light on its passage through a transparent medium when placed in a strong magnetic field.

The medium only possesses such properties while in the field.

In a ray of ordinary light the vibrations of the ether particles are at right angles to the direction of the ray, or to the direction in which the light is moving. But the vibrations occur indiscriminately in all planes passing through the line of direction. Under certain circumstances, all the ether particles may be caused to move in planes that are parallel to one another. Such a beam of light is called a *plane polarized beam*.

A plane polarized beam of light, when passed through many transparent substances, will have its ether particles vibrating in the same plane when it emerges from the medium, as it had before it entered. Some transparent substances, however, possess the property of *rotating* or *turning* the *plane of polarization of the light* to the right

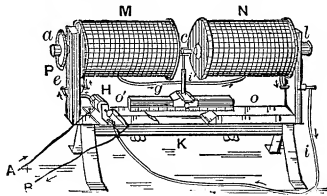

Fig. 496. Magneto-Optic Rotation.

or to the left. This property is called respectively *right-handed rotary polarization*, and *left-handed rotary polarization*.

Many substances that ordinarily possess no power of rotary polarization acquire this power when placed in a magnetic field. This property of a magnetic field was discovered by Faraday.

The effect is to be ascribed to the strain produced in the transparent medium by the stress of the magnetic field. It may be caused in solid bodies by mechanical force.

The apparatus for demonstrating the rotation of the plane of polarization by a magnetic field is shown in Fig. 496.

A powerful electro-magnet, M, M, is provided with a hollow core. The substance c, is placed in the field produced by the approached poles, and its action on the light of a lamp, placed at the end l, is observed by suitable apparatus at a.

Rubber of Electrical Machine.—A cushion of leather, covered with an electric amalgam, and employed to produce electricity by its friction against the plate or cylinder of a frictional electric machine. (See *Machine, Frictional Electric*.)

Rubbing Contact.—(See *Contact, Rubbing*.)

Ruhmkorff Coil.—(See *Coil, Ruhmkorff*.)

Ruhmkorff's Commutator.—(See *Commutator, Ruhmkorff's*.)

Rule, Ampère's, for Effect of Current on Needle — — A magnetic needle, when placed near a conductor through which a current is flowing, has its north pole deflected to the left of the observer, who is supposed to be swimming with the current and facing the needle.

S

S.—A contraction employed for second.

S. H. M.—A contraction employed for simple harmonic motion.

S. N. Code.—A contraction for single needle code.

S. W. G.—A contraction for Standard Wire Gauge.

Saddles, Telegraphic — — Brackets placed on the top of telegraphic poles for the support of the insulators.

Saddle brackets are usually employed for the wire attached to the top of a telegraphic pole. (See *Pole, Telegraphic*.)

Safe Carrying Capacity of a Conductor. — (See *Capacity, Safe Carrying, of a Conductor*.)

Safety Catch.—(See *Catch, Safety*.)

Safety Device for Multiple Circuits.—(See *Device, Safety, for Multiple Circuits*.)

Safety Fuse.—(See *Fuse, Safety*.)

Safety Lamp, Electric — — (See *Lamp, Electric Safety*.)

Safety Plug.—(See *Plug, Safety*.)

Safety Strip.—(See *Strip, Safety*.)

Saint Elmo's Fire.—(See *Fire, St. Elmo's*.)

Salient Magnetic Pole.—(See *Pole, Magnetic, Salient.*)

Saline Creeping.—(See *Creeping, Saline.*)

Salts, Electrolysis of — —The decomposition of a salt into its electro-positive and negative radicals or ions. (See *Electrolysis.*)

Sandy Deposit, Electro-Metallurgical — —(See *Deposit, Electro-Metallurgical, Sandy.*)

Saturated Solution.—(See *Solution, Saturated.*)

Saturation, Magnetic — —The maximum magnetization which can be imparted to a magnetic substance.

The condition of iron, or other paramagnetic substance, when its intensity of magnetization is so great that it fails to be further sensibly magnetized by any magnetic force, however great.

When the core of an electro-magnet is saturated by the passage of an electric current, the only further increase of its magnetization that is possible, is that due to the magnetic field of the increased current which may be sent through its coils. This is comparatively insignificant.

A permanent magnet is sometimes said to be super-saturated, that is, to have received more magnetism than it can retain for any considerable time after its magnetization.

In the saturated field magnets of a dynamo-electric machine the magnetic density is seldom taken at a larger value than 16,000 lines per square centimetre of area of cross-section. But this is only *practical* saturation, since Ewing has forced 45,300 lines per square centimetre by using an enormously high magnetizing force ($H = 24,500$).

Saturation, Magnetic, Diacritical Point of — —A term proposed by S. P. Thompson for such a value of the co-efficient of magnetic saturation, that the core is magnetized to exactly one-half its possible maximum of magnetization.

Saw, Electric — —A platinized steel wire, employed while incandescent for cutting hard substance.

Scale, Tangent — —A scale designed for use with a galvanometer, on which the values of the tangents are marked, instead of

equal degrees as ordinarily, thus avoiding the necessity of finding from tables the tangents corresponding to the degrees.

Such a scale may be constructed as follows: Draw the *tangent* B T, to the circle, Fig. 497, and lay off on it any number of equal divisions or parts, as, for example, the thirty shown in the annexed figure. Connect these parts with the centre C, of the circle. The arc of the circle will

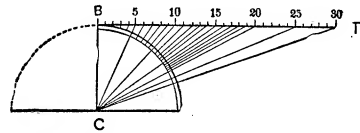

Fig. 497. Tangent Scale.

thus be divided into parts proportional to the value of the tangents of the angles.

These parts are more nearly equal the nearer they are to B, and grow smaller and smaller the further they are from B. In tangent galvanometers it is therefore very difficult to accurately determine the current strength when the deflections of the needle are very large.

Scale, Thermometer, Centigrade — —A thermometer scale, in which the length of the thermometric tube between the melting point of ice and the boiling point of water is divided into one hundred equal parts or degrees.

Centigrade degrees are indicated by a C., thus 0 degree C. or 100 degrees C., to distinguish them from Fahrenheit degrees that are marked F. In the Fahrenheit scale the freezing point of water is taken at 32 degrees, and the boiling point at 212 degrees.

Scale, Thermometer, Fahrenheit's — —A thermometer scale in which the length of the thermometer tube between the melting point of ice and the boiling point of water is divided into 180 equal parts called degrees.

Fahrenheit degrees are indicated by an F., thus, 32 degrees F.

The freezing point of water in Fahrenheit's scale is marked 32 degrees F., and the boiling point of water is marked 212 degrees F.

Schiseophone.—An electro-mechanical appliance for detecting flaws and internal defects in rails or other metallic masses.

The schiseophone consists essentially in the combination of a microphone and telephone with a mechanical hammer and induction balance.

Schweigger's Multiplier.—(See *Multiplier, Schweigger's.*)

Scintillating Jar.—(See *Jar, Scintillating.*)

Scratch Brush.—(See *Brush, Scratch.*)

Scratch Brush, Circular — —(See *Brush, Scratch, Circular.*)

Scratch Brush, Hand — —(See *Brush, Scratch, Hand.*)

Scratch Brushing.—(See *Brushing, Scratch.*)

Screen, Electric — —A closed conductor placed over a body to screen or protect it from the effects of external electrostatic fields.

An electric screen is sometimes called an electric shield.

The ability of a closed, hollow conductor to act as a screen, arises from the fact that all points on its inner surface are at the same potential, and therefore are not affected by an increase or decrease in the potential of the outside of the conductor as compared with that of the earth. (See *Net, Faraday's.*)

No considerable thickness is required for the efficient operation of an electric screen.

Screen, Magnetic — —A hollow box whose sides are made of thick iron, placed around a magnet or other body so as to cut it off or screen it from any magnetic field external to the box.

Magnetic screens are placed around delicate galvanometers to avoid any variations in their field due to extraneous masses of iron or neighboring magnets. They are also sometimes placed around watches to shield or screen the works from the effects of magnetism.

To act effectively, when the external fields are at all powerful, magnetic screens must be made of thick iron. They differ in this respect from electrostatic shields, which will afford protection against electrostatic charges although they may be but mere films.

Screen, Methven's — —A vertical rectangular metallic screen used in connection with a standard argand burner, for furnishing a standard amount of light for photometric purposes.

In a rectangular screen a small vertical slot is made of such dimensions as to permit an amount

of light to pass just equal to two standard candles. The proper burning of the argand lamp is determined by supplying sufficient gas to produce a flame exactly 3 inches high. The glass chimney used in the burner is 6 inches high, and is provided with two horizontal wires placed on each side of the burner at the required height.

Methven's screen possesses the advantage of being easily used and of furnishing a reliable standard of light. Extended experiments made with it appear to show that the amount of light produced depends rather on the height of the gas flame than on the quality of the gas itself. In using Methven's screen care should be taken

(1.) To see that the gas flame is of exactly the required height.

(2.) That the chimney on the lamp is quite clean.

(3.) That the top of the flame is as regular as possible.

As this last point is almost impossible to obtain in actual practice, the flame is adjusted so that the highest point extends about one-eighth of an inch above the height of the horizontal wires.

(4.) That the lamp and apparatus be permitted to acquire its normal temperature before the readings are taken.

Fig. 498 shows the construction of the ordinary Methven standard screen. The vertical slot in the screen is placed as shown before the standard argand burner. Horizontal wires

for the adjustment of the height of the flame are placed one on each side of the gas chimney.

Screening, Electrostatic — —Screening or shielding from the inductive effects of a charge.

A continuous metallic surface surrounding an air space to be shielded, completely protects any body placed within such air space from electrostatic influence. (See *Cube, Faraday's.*)

Screening, Magnetic — —Preventing magnetic induction from taking place by interposing a metallic plate, or a closed circuit of insulated wire, between the body producing

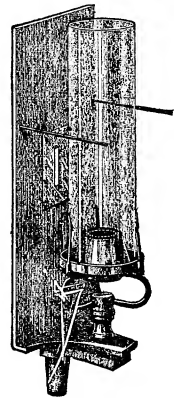

Fig. 498. Methven's Standard Screen.

the magnetic field and the body to be magnetically screened.

A magnetic needle is screened from the action of the earth's field by placing it inside a hollow iron box, which prevents the lines of force of the earth's field from passing through it by concentrating them on itself. This action is dependent on the fact that iron is paramagnetic and therefore offers the lines of force less resistance through its mass than elsewhere. A plate of copper would not effect any such magnetic shielding or screening.

In any magnetic field, however, in which the strength of the field is undergoing rapid, periodic variations, a plate of copper or other electric conductor may act as a screen to protect neighboring conductors from the effects of magnetic induction, and its ability to thoroughly effect such a screening will depend directly on its conducting power.

If, for example, the copper plate *c* (Fig. 499), be interposed between a coil of copper ribbon *a*, and the fine wire coil *b*, it will greatly reduce the intensity of the induced currents, produced when rapidly alternating currents are sent through *a*. If, however, the copper plate be slit, as shown to the right at *a*, the screening effect is lost, but is regained if the slit be connected by a conductor. Similarly a flat coil of insulated wire effects no screening action when open, but when closed acts as the uncut copper plate.

Here the screening action is due to the fact that the energy of the field is spent in producing eddy currents in the interposed metal screen or coils. If the metal screen is discontinuous in the direction in which the eddy currents tend to flow, the inability of the screen to absorb the energy as eddy currents prevents its action as a screen.

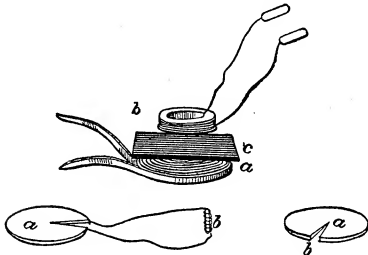

Fig. 499.

The word magnetic screening is generally employed in the latter sense of preventing magnetic

induction from occurring in a neighboring conductor, by interposing some conducting substance in which eddy currents can be freely established.

As to the efficiency of the screening action, if the makes-and-breaks do not follow one another very rapidly, the following principles can be proved:

(1.) If the screening material have absolutely no electrical resistance it will effect a perfect magnetic screening when placed between the primary and secondary, no matter what its thickness may be.

(2.) If the screen have a finite conductivity, the screening will be imperfect, unless the thickness of the material employed is considerable.

If, however, the makes-and-breaks follow one another very rapidly, then

The screening effect of even imperfect conductors will become manifest with comparatively thin screens of metal.

As to magnetic screening, therefore, it follows that the less the conductivity, the greater must be the speed of reversal, in order that the screening action may be effective.

Where a screen of iron is employed, an additional effect is produced by the fact that the small magnetic resistance of the metal, or its conductivity for lines of magnetic force, causes the lines of induction to pass through its mass, and thus effect a screening action for the space on the other side. This action is, by some, called magnetic screening.

In the case of iron screens, considerable thickness is required in the metal plate, in order to obtain efficient screening action of this latter character. On account of this action of iron, in conducting away lines of force, a much smaller speed of reversal is required, in order to obtain effective screening action, where plates of iron are used, than in the case of plates of other metal.

The apparatus shown in Fig. 500 was employed

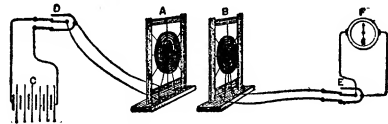

Fig. 500. Willoughby Smith's Apparatus.

by Mr. Willoughby Smith, in studying the effects of magnetic screening.

The flat coils A, and B, were employed for the primary and secondary coils respectively, and were connected to the battery C, and the galva-

nometer F, as shown. Current reversers, D and E, were so arranged as to reverse galvanometer and battery alternately, and so cause the opposite induced currents to affect the galvanometer in the same direction. If the commutators were caused to reverse the current slowly, a plate of copper interposed between A and B, produced but little effect on the galvanometer, but if the reversers were driven at a very rapid rate, a marked decrease of deflection occurred.

The screening action of the metals, or their ability to diminish the galvanometer deflection, is in the order of their electrical conductivity, except in the case of iron, which, as we have seen already, has an additional screening power, due to its conducting away the lines of magnetic force.

It follows from the preceding principles that the use of lead covered cables, for the conveyance of periodic currents, of the frequency of, say, sixty to one hundred alternations per second, is of but little or no advantage for protecting neighboring telephones from inductive action, because

- (1.) Lead is a poor conductor.
- (2.) The rapidity of alternation is too slow.

J. J. Thomson made some experiments with electrical oscillations produced by resonance, of about 10^8 in frequency. He obtained this frequency of oscillation from oscillations set up in the primary of an induction coil, in a secondary circuit of suitable dimensions. The presence of these secondary vibrations or waves was shown by means of the sparks seen at the terminals of a spark-micrometer circuit. Under these circumstances he found that the interposition of a thin sheet of tin foil or gold leaf at once completely stopped the secondary sparks by the shielding action it exerted.

Screening, Magnetostatic — —Screening from the inductive effect of a stationary magnetic field.

Magnetostatic screening differs from electrostatic screening in that the plate of iron or other paramagnetic material surrounding the space to be screened must have a fairly considerable thickness. This arises from the fact that the magnetic susceptibility of the substance is not infinitely great.

Screw, Binding — —A name sometimes applied to a binding post. (See *Post, Binding*.)

Seal, Hermetical — —Such a sealing of

a vessel, designed to hold a vacuum, or gaseous atmosphere under pressures greater or less than that of the atmosphere, as will prevent either the entrance of the external atmosphere into the vessel, or the escape of the contained gas into the atmosphere.

Hermetical sealing may be accomplished either by the use of suitable cements, or by the direct fusion of the walls of the containing vessel. The latter method is generally employed.

Search Light, Automatic — —(See *Light, Search, Automatic*.)

Search Light, Electric — —(See *Light, Search, Electric*.)

Secohm.—The practical unit of self-induction, or the practical unit of inductance.

The secohm is equivalent to a length equal to that of an earth quadrant, or 10^9 centimetres.

The word secohm is a contraction for second, ohm, and implies the fact that the product of the ohm and the second are taken.

The word henry is now generally used in the United States for secohm. (See *Henry*.)

Secohmmeter.—An apparatus for measuring the co-efficient of self-induction, mutual induction and capacity of conductors. (See *Secohm, Induction, Mutual, Induction, Self*.)

The principle of the secohmmeter depends upon successively performing the cycle of magnetic operations, by making and breaking the circuit of a galvanometer by means of a commutator capable of working at a definite speed.

Second, Ampère — —One ampère flowing for one second. (See *Hour, Ampère*.)

Second, Watt — —A unit of electrical work.

A watt-second equals the work due to the expenditure of an electrical power of one watt for one second. It is the same as a volt-coulomb.

The *watt-second* and the *H. P. hour*, etc., are units of *work*, since $\text{Power} = \frac{\text{Work}}{\text{Time}}$, therefore, $\text{power} \times \text{time} = \text{work}$.

Secondary Battery.—(See *Battery, Secondary*.)

Secondary Battery, Cell of — —(See *Cell, Secondary*.)

Secondary Cell.—(See *Cell, Secondary*.)

Secondary Cell, Jar of — —(See *Jar of Secondary Cell*.)

Secondary Clock.—(See *Clock, Secondary*.)

Secondary Coil.—(See *Coil, Secondary*.)

Secondary Currents.—(See *Currents, Secondary*.)

Secondary, Fixed — —The secondary of an induction coil, that, as is common in such coils, is fixed, as contradistinguished from a movable secondary. (See *Secondary, Movable*.)

Secondary Generator.—(See *Generator, Secondary*.)

Secondary Impressed Electromotive Force.—(See *Force, Electromotive, Secondary Impressed*.)

Secondary, Movable — —The secondary conductor of an induction coil, which, instead of being fixed as in most coils, is movable.

The peculiar movements observed in the secondary of an induction coil when the secondary is free to move, have been carefully studied by Prof. Elihu Thomson. The secondaries employed for this purpose are in the shape of rings, discs, spheres, wedges, bars, wheels, etc., etc.

The primary is in the form of a straight cylindrical coil surrounding a straight core. The coils are traversed by rapidly alternating currents and possess considerable impedance.

Among the many phenomena concerning the behavior of movable secondaries in such a rapidly alternating field are the following, viz.:

(1.) A metallic ring, resting on lugs attached to the coils of the primary, is thrown violently off the magnet on the passage of alternating currents through the primary.

(2.) Two metallic rings of the same diameter brought into the field are mutually attracted to each other, with sufficient force to sustain the weight of one of the rings when the other ring is held in the field.

(3.) Metallic spheres are set into rotation when so held near the primary pole as to be shielded

from the action of part of the rapidly alternating field. When held on one side of the pole, this rotation occurs in the opposite direction to that when held on the opposite side.

(4.) Metallic discs similarly placed are similarly set into rotation.

(5.) The speed of rotation of spheres or discs varies in different positions.

(6.) Spheres or discs of diamagnetic substances attain their maximum rotation when held in position at right angles to those of paramagnetic substances.

(7.) Bars of steel or substances possessing high coercive power, placed dissymmetrically on the primary as regards their centres of gravity, exhibit the phenomena of a shifting magnetic field. (See *Field, Magnetic, Shifting*.)

(8.) A wedge-shaped piece of steel placed with a flat face on the primary, exhibits a shifting magnetic field, and acts on movable metallic masses near it, just as though a fluid substance was escaping with great velocity from its edges.

Secondary Movers.—(See *Movers, Secondary*.)

Secondary Plate of Condenser.—(See *Plate, Secondary, of Condenser*.)

Secondary Spiral.—(See *Spiral, Secondary*.)

Secretion Current.—(See *Current, Secretion*.)

Section Line of Electric Railway.—(See *Railroads, Electric, Section Line of*.)

Section, Neutral, of Magnet — —A section passing through the neutral line or equator of a magnet. (See *Line, Neutral, of a Magnet, Magnet, Equator of*.)

Section, Trolley — —A single continuous length of trolley wire, with or without its branches.

Sectional or Divided Overhead System of Motive Power for Electric Railroads.—(See *Railroads, Electric, Sectional Overhead System of Motive Power for*.)

Sectional or Divided Surface System of Motive Power for Electric Railroads.—(See *Railroads, Electric, Sectional Surface System of Motive Power for*.)

Sectional or Divided Underground System of Motive Power for Electric Railroads.—(See *Railroads, Electric, Sectional Underground System of Motive Power for.*)

Sectional Plating.—(See *Plating, Sectional.*)

Sectional Plating Frame.—(See *Frames, Sectional Plating.*)

Seebeck Effect.—(See *Effect, Seebeck.*)

Seismograph, Electric — —An apparatus for electrically recording the direction and intensity of earthquake shocks.

Seismograph, Micro — —An electric apparatus for photographically registering the vibrations of the earth produced by earthquakes or other causes.

The micro-seismograph consists essentially of a microphone placed on the ground and connected with a telephone. A small concave mirror movable about a horizontal axis is supported on a plate of aluminium supported on a platinum wire connected with the diaphragm of the telephone. The movements of the diaphragm of the telephone are permanently recorded on a strip of sensitized paper that is moved before the mirror.

Selective Absorption.—(See *Absorption, Selective.*)

Selenium.—A comparatively rare element generally found associated with sulphur.

Selenium Battery.—(See *Battery, Selenium.*)

Selenium Cell.—(See *Cell, Selenium.*)

Selenium Eye.—(See *Eye, Selenium.*)

Selenium Photometer.—(See *Photometer, Selenium.*)

Self-Induced Current.—(See *Currents, Self-Induced.*)

Self-Induction.—(See *Induction, Self.*)

Self-Induction, Co-efficient of — —(See *Induction, Self Co-efficient of.*)

Self-Recording Magnetometer.—(See *Magnetometer, Self-Recording.*)

Self-Registering Wire Gauge. — (See *Gauge, Wire, Self-Registering.*)

Self-Winding Clock.—(See *Clock, Self-Winding.*)

Semaphore.—A variety of signal apparatus employed in railroad block systems.

The semaphore used on the Pennsylvania Railroad consists of a wooden post, in the neighborhood of twenty feet in height, on which a wooden arm or blade, six feet in length and a foot in width, is displayed.

When the block is clear, during the day the arm is placed pointing downwards at an angle of 75 degrees with the horizontal; during night semaphore displays a white light. When the block is not clear, the arm or blade is placed in a horizontal position by day, or displays a red light at night. (See *Railroads, Block System for.*)

Semaphore Arm.—(See *Arm, Semaphore.*)

Semaphore Indicator.—(See *Indicator, Semaphore.*)

Sender, Zinc — —A device employed in telegraphic circuits, by means of which, in order to counteract the retardation produced by the charge given to the line, a momentary reverse current is sent into the line after each signal.

A zinc sender generally consists of a low resistance Siemens relay introduced between the line and the front contact of the signaling key.

Sensibility, Electro — —An effect produced on a sensory nerve by its electrization.

Sensibility of Galvanometer.—(See *Galvanometer, Sensibility of.*)

Sensitive Thread Discharge.—(See *Discharge, Sensitive Thread.*)

Separate Coil Dynamo-Electric Machine.—(See *Machine, Dynamo-Electric, Separate Coil.*)

Separate Touch, Magnetization by — —(See *Touch, Separate.*)

Separately Excited Dynamo.—(See *Dynamo, Separately Excited.*)

Separately Excited Dynamo-Electric Machine.—(See *Machine, Dynamo-Electric, Separately Excited.*)

Separator.—An insulating sheet of ebonite, or other similar substance, corrugated and perforated so as to conform to the outline of the plates of a storage battery, and placed between them at suitable intervals, in such a

Series-Wound Motor.—(See *Motor, Series-Wound*.)

Service Conductors.—(See *Conductors, Service*.)

Service, Street — —In a system of incandescent lamp distribution that portion of the circuit which is included between the main and the service cut-out.

Serving, Cable — —The covering of hemp or jute spun around the insulated core of a cable to act as a protection against the pressure of the iron wire which forms the armor of the cable.

Shackling a Wire.—Inserting an insulator between the two ends of a cut wire.

Shaded or Screened.—Cut off or screened from the effects of an electrostatic or magnetic field. (See *Screening, Magnetic. Screen, Magnetic. Screen, Electric*.)

Shadow, Electric — —A term sometimes used for molecular shadow. (See *Shadow, Molecular*.)

Shadow, Molecular — —The comparatively dark space on those parts of the walls of Crookes' tubes, which have been protected from molecular bombardment by suitably placed screens.

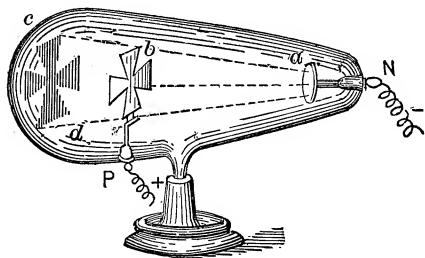

Fig. 501. Molecular Shadow.

If a, in the Crookes tube, shown in Fig. 501, be connected with the negative pole of an electric source, and the cross-shaped mass of aluminium at b, be connected with the positive electrode, on the passage of a series of rapid discharges, *phosphorescence* is produced by the molecular bombardment from a, in all parts of the vessel opposite a, except those lying in the

projection of its geometrical shadow. (See *Phosphorescence, Electric*.)

Shadow Photometer.—(See *Photometer, Shadow*.)

Shaft, Driven — —A shaft which receives its power from the driving shaft. (See *Mover, Prime*.)

Shaft, Driving — —The main line of shafting which takes its power directly from the prime mover.

Shallow-Water Submarine Cable.—(See *Cable, Submarine, Shallow-Water*.)

Sheath, Protective — —A device attached to a transformer or converter, to prevent any connection from taking place between the high-potential primary circuit and the low-potential secondary circuit.

The protective sheath devised by Prof. Elihu Thomson consists essentially in an earth-connected copper strip or divided plate interposed between the windings for the secondary and primary circuit. Should the primary circuit lose its high insulation it becomes grounded.

Sheet, Current — —The sheet into which a current spreads when the wires of any source are connected at any two points near the middle of a very large and thin conductor.

A continuous electric current does not flow through the entire mass of a conductor in any single line of direction. If the terminals of any source are connected to neighboring parts of a greatly extended thin conductor, the current spreads out in a thin sheet known as a *current sheet*, and instead of flowing in a straight line between the points, spreads over the plate in *curved lines of flow*, which, so far as shape is concerned, are not unlike the *lines of magnetic force*.

Sheet Lightning. — (See *Lightning, Sheet*.)

Shellac.—A resinous substance possessing valuable insulating properties, which is exuded from the roots and branches of certain tropical plants.

The specific inductive capacity of shellac as compared with air is 2.74.

Shell, Magnetic — —A sheet or layer consisting of magnetic particles, all of whose north poles are situated in one of the flat surfaces of the layer, and the south poles in the opposite surface. (See *Magnetism, Lamellar Distribution of*.)

Shell Transformer.—(See *Transformer, Shell*.)

Shield, Magnetic, for Watches — —A hollow case of iron, in which a watch is permanently kept, in order to shield it from the influence of external magnetic fields. (See *Screen, Magnetic*.)

Shifting Magnetic Field.—(See *Field, Magnetic, Shifting*.)

Shifting Zero.—(See *Zero, Shifting*.)

Ships, Lightning Rods for — —(See *Rod, Lightning, for Ships*.)

Ship's Sheathing, Electric Protection of — —Attaching pieces of zinc to the copper sheathing of a ship for the purpose of preventing the corrosion of the copper by the water. (See *Metals, Electrical Protection of*.)

Shock, Break — —A term sometimes employed in electro-therapeutics for the physiological shock produced on the opening or breaking of an electric circuit.

Shock, Electric — —The physiological shock produced in an animal by an electric discharge.

Shock, Opening — —The physiological shock produced on the opening or breaking of an electric circuit.

Shock, Static — —A term employed in electro-therapeutics for a mode of applying Franklinic currents or discharges, by placing the patient on an insulating stool and applying one pole of a static machine provided with small condensers or Leyden jars, to an insulated platform on which the patient is placed, while the other pole is applied to the body of the patient by the operator.

The electrode applied to the body of the patient is provided with a ball electrode. Shocks are given to the patient on the approach of this electrode by the discharge of the Leyden jars.

Short-Arc System of Electric Lighting.—(See *Lighting, Electric, Short-Arc System*.)

Short-Circuit.—To establish a short circuit. (See *Circuit, Short*.)

Short-Circuit Key.—(See *Key, Short-Circuit*.)

Short-Circuiting.—Establishing a short circuit. (See *Circuit, Short*.)

Short-Circuiting Plug.—(See *Plug, Short-Circuiting*.)

Short-Coil Magnet.—(See *Magnet, Short-Coil*.)

Short-Core Electro-Magnet.—(See *Magnet, Electro, Short-Core*.)

Short-Shunt Compound-Wound Dynamo-Electric Machine.—(See *Machine, Dynamo-Electric, Compound-Wound, Short-Shunt*.)

Shunt.—An additional path established for the passage of an electric current or discharge.

Shunt.—To establish an additional path for the passage of an electric current or discharge.

Shunt and Separately Excited Dynamo-Electric Machine.—(See *Machine, Dynamo-Electric, Shunt and Separately Excited*.)

Shunt Circuit.—(See *Circuit, Shunt*.)

Shunt Dynamo-Electric Machine.—(See *Machine, Dynamo-Electric, Shunt-Wound*.)

Shunt, Electric Bell — —(See *Bell, Shunt, Electric*.)

Shunt, Electro-Magnetic — —In a system of telegraphic communication an electro-magnet whose coils are placed in a shunt circuit around the terminals of the receiving relay.

The electro-magnetic shunt operates by its self-induction. Its poles are permanently closed by a soft iron armature so as to reduce the resistance of the magnetic circuit. (See *Induction, Self*.)

On making the circuit in the coils of a receiving relay, a current is produced in the coils of the electro-magnetic shunt in the *opposite direction* to the relay current; and, on breaking the circuit in the relay, a current is produced in the coils of the electro-magnetic shunt in the *same direction* as the current in the relay.

The connection of the coils of the electro-magnetic shunt with those of the receiving relay, however, is such that on making the circuit in the relay the current in the shunt coils flows through the relay in the same direction, and on breaking the circuit it flows in the opposite direction. Therefore this shunt produces the following effects:

(1.) At the commencement of each signal in the receiving relay, it produces an induced current in the same direction which strengthens the current in the relay.

(2.) At the ending of each signal in the receiving relay, it produces a current in the opposite direction, which hastens the motion of the tongue of the polarized relay. (See *Relay, Polarized.*)

Shunt, Galvanometer — — A shunt placed around a sensitive galvanometer for the purpose of protecting it from the effects of a strong current, or for altering its sensibility. (See *Shunt.*)

The current which will flow through the shunt wire depends on the relative resistance of the galvanometer and of the shunt. In order that only $\frac{1}{10}$, $\frac{1}{100}$, or $\frac{1}{1000}$, of the total current shall pass through the galvanometer, it is necessary that the resistances of the shunt shall be the $\frac{1}{9}$, $\frac{1}{99}$, or $\frac{1}{999}$, of the galvanometer resistance.

Fig. 502 shows a shunt, in which the resistances, as compared with that of the galvanometer, are those above referred to. The galvanometer terminals are connected at N, N. Plug keys are used to connect one or another of the shunts with the circuit. (See *Shunt, Multiplying Power of.*)

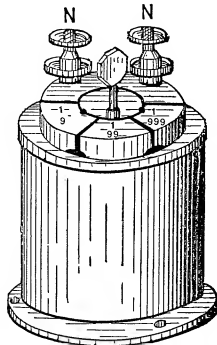

Fig. 502. Galvanometer Shunt.

Shunt, Magnetic — — An additional path of magnetic material provided in a mag-

netic circuit for the passage of the lines of force.

Shunt, Multiplying Power of — — A quantity, by which the current flowing through a galvanometer provided with a shunt, must be multiplied, in order to give the total current.

The multiplying power of a shunt may be determined from the following formula, viz.:

$A = \left(\frac{s+g}{s}\right) \times C$, in which $\frac{s+g}{s}$ = the multiplying power of a shunt whose resistance is s ; g , is the galvanometer resistance; C , the current through the galvanometer, and A , the total current passing; s and g , are taken in *ohms*, and C and A , in *ampères*.

Suppose, for example, that but $\frac{1}{10}$ the entire current is to flow through the galvanometer; then the resistance of the shunt must evidently be $\frac{1}{9}g$, for,

$$\frac{s}{s+g} = \frac{I}{I+9} = \frac{I}{10};$$

or, $10s = s+g$. $10s - s = g$.. $9s = g$; or, $s = \left(\frac{1}{9}\right)g$.

Shunt or Reducteur for Ammeter.—(See *Reducteur or Shunt for Ammeter.*)

Shunt Ratio.—The ratio existing between the shunt and the circuit which it shunts. (See *Shunt, Multiplying Power of.*)

Shunt, Relay, Stearns' — — A shunt employed in the differential method of duplex telegraphy to short-circuit the relay and then permit the line current to be cut off directly after it has completed its work in closing the local circuit.

The use of the relay shunt permits the slackening of the armature spring of the relay, because the decreased duration of the line current does not produce so strong a magnetization of the iron.

Shunt-Turns of Dynamo-Electric Machine.—(See *Turns, Shunt, of Dynamo-Electric Machine.*)

Shunt-Wound Dynamo-Electric Machine.—(See *Machine, Dynamo-Electric, Shunt-Wound.*)

Shunt-Wound Motor.—(See *Motor, Shunt-Wound.*)

Shunting.—Establishing a shunt circuit.

Shuttle Armature.—(See *Armature, Shuttle.*)

Side A, of Quadruplex Table.—(See *Table, Quadruplex, A, Side of.*)

Side B, of Quadruplex Table.—(See *Table, Quadruplex, B, Side of.*)

Side Flash.—(See *Flash, Side.*)

Sidero-Magnetic.—(See *Magnetic, Sidero.*)

Siemens' - Armature Electro-Magnetic Bell.—(See *Bell, Electro-Magnetic, Siemens' Armature Form.*)

Siemens' Differential Voltmeter.—(See *Voltmeter Siemens' Differential.*)

Siemens' Electric Pyrometer.—(See *Pyrometer, Siemens' Electric.*)

Siemens-Halske Voltaic Cell.—(See *Cell, Voltaic, Siemens-Halske.*)

Siemens' Water Pyrometer.—(See *Pyrometer, Siemens' Water.*)

Signal Arm.—(See *Arm, Signal.*)

Signal, Electric Tell-Tale — —An electrically operated signal, generally silent, whereby the appearance of a white or colored disc, on a black or otherwise uniformly colored surface, indicates the occurrence of a certain predetermined event.

Signal Service for Electric Railways.—(See *Railroads, Electric, Signal Service System for.*)

Signals, Electro-Pneumatic — —Signals operated by the movements of diaphragms or pistons moved by compressed air, the escape of which is controlled electrically.

Signaling, Balloon, for Military Purposes — —Transmitting intelligence of the movements of an enemy's army obtained from observations made in balloons by means of telephone circuits connected with the balloon.

Signaling, Curb — —In cable telegraphy a system for avoiding the effects of retardation by rapidly discharging the cable before another electric impulse is sent into

it, by reversing the battery, before connecting it to earth, and then connecting to earth before beginning the next signal.

Signaling, Double-Curb — —In curb signaling, a method by which the cable, after being connected with the battery for sending a signal, is subjected to a reverse battery, but instead of being put to earth after this connection, as in single-curb signaling, the battery is again reversed and connected to earth.

The time during which the cable is connected to the reversed battery before being put to earth, that is, the time during which it receives the positive and negative currents, may be made of any suitable duration.

Signaling, Double-Current — —Signaling by means of currents that alternately change their direction.

Double-current signaling was devised by Varley in order to avoid the effects of the induction of underground conductors on Morse telegraphic apparatus. The idea of reversing the direction of the current was to hasten the discharge of the wire, which was prolonged by induction. Double-current working, however, possesses other advantages, and is used in duplex and quadruplex transmission.

Signaling, Single-Curb — —In curb signaling, a method by which the cable, after connection with the battery for sending a signal, is subjected to a reverse battery current, and then put to earth before again being connected to the battery for sending the next signal.

Signaling, Single-Current — —Signaling by making or breaking the circuit of a single current.

Single-current signaling is of two kinds, viz.:

(1.) *Open-Circuit Signaling*, in which the batteries are fixed at each station, and are in circuit only when signaling.

(2.) *Closed-Circuit Signaling*, where the batteries are divided, one half generally being at each end of the line, and so connected that both sets flow in the same direction.

Signaling, Single-Current, Closed-Circuit — —A system of single-circuit signaling in which the sending batteries are placed at each end of the line and are so connected as

to remain always in circuit. (See *Signaling, Single-Current.*)

Signaling, Single-Current, Open-Circuit — — A system of single-current signaling in which the sending batteries, fixed at each station, are in circuit during signaling only. (See *Signaling, Single-Current.*)

Signaling, Velocity of Transmission of — — The speed or rate at which successive signals can be sent on any line without the retardation producing serious interference. (See *Retardation.*)

Silent Discharge.—(See *Discharge, Silent.*)

Silver Bath.—(See *Bath, Silver.*)

Silver Chloride Voltaic Cell.—(See *Cell, Voltaic, Silver Chloride.*)

Silver Plating.—(See *Plating, Silver.*)

Silver Voltmeter.—(See *Voltmeter, Silver.*)

Silvered Plumbago.—(See *Plumbago, Silvered.*)

Silvering, Electro — — Covering a surface with a coating of silver by electro-plating. (See *Plating, Electro.*)

Electro-plating with silver.

Silurus Electricus.—The electric eel. (See *Eel, Electric.*)

Simple Arc.—(See *Arc, Simple.*)

Simple Circuit.—(See *Circuit, Simple.*)

Simple Electric Candle-Burner.—(See *Burner, Simple Candle Electric.*)

Simple-Harmonic Current.—(See *Current, Simple-Harmonic.*)

Simple-Harmonic Curve.—(See *Curve, Simple-Harmonic.*)

Simple-Harmonic Motion.—(See *Motion, Simple-Harmonic.*)

Simple Magnet.—(See *Magnet, Simple.*)

Simple-Periodic Current.—(See *Currents, Simple-Periodic.*)

Simple-Periodic Electromotive Force.—(See *Force, Electromotive, Simple-Periodic.*)

Simple-Periodic Motion.—(See *Motion, Simple-Periodic.*)

Simple Radical.—(See *Radical, Simple.*)

Simple-Sine Motion.—(See *Motion, Simple-Sine.*)

Simple Voltaic Cell.—(See *Cell, Voltaic, Simple.*)

Simplex Telegraphy.—(See *Telegraphy, Simplex.*)

Sims-Edison Torpedo.—(See *Torpedo, Sims-Edison.*)

Sine Galvanometer.—(See *Galvanometer, Sine.*)

Single-Brush Rocker.—(See *Rocker, Single-Brush.*)

Single-Cup Insulator.—(See *Insulator, Single-Shed.*)

Single Curb.—(See *Curb, Single.*)

Single-Current Signaling.—(See *Signaling, Single-Current.*)

Single-Curve Trolley Hanger.—(See *Hanger, Single-Curve Trolley.*)

Single-Fluid Hypothesis of Electricity.—(See *Electricity, Single-Fluid Hypothesis of.*)

Single-Fluid Voltaic Cell.—(See *Cell, Voltaic, Single-Fluid.*)

Single-Loop Armature.—(See *Armature, Single-Loop.*)

Single-Magnet Dynamo-Electric Machine.—(See *Machine, Dynamo-Electric, Single-Magnet.*)

Single-Pair Yoke.—(See *Yoke, Single-Pair.*)

Single-Shackle Insulator.—(See *Insulator, Single-Shackle.*)

Single-Shed Insulator.—(See *Insulator, Single-Shed.*)

Single-Stroke Electric Bell.—(See *Bell, Single-Stroke Electric.*)

Single Touch.—(See *Touch, Single.*)

Single-Wire Cable.—(See *Cable, Single-Wire.*)

Single-Wire Circuit.—(See *Circuit, Single-Wire.*)

Sinistrorsal Solenoid or Helix.—(See *Solenoid, Sinistrorsal.*)

Sinuous Currents.—(See *Current, Sinuous.*)

Siphon, Electric — —A siphon in which the stoppage of flow, due to the gradual accumulation of air, is prevented by electrical means.

In the electric siphon, an opening is provided at the highest part of the bend of the siphon tube, and a chamber is attached thereto, provided with a float. Contact points are so connected with the float that when it falls, contact is made, and when it rises, contact is broken.

The closing of the circuit, on the fall of the float, operates an electric motor which drives an air pump which exhausts the air from the siphon. Or the float being raised in the siphon, the contact is broken and the operation of the pump is stopped.

Siphon Recorder.—(See *Recorder, Siphon.*)

Sir William Thomson's Standard Cell.—(See *Cell, Voltaic, Standard, Sir William Thomson's.*)

Skin Effect.—(See *Effect, Skin.*)

Skin, Faradization of — —The therapeutic treatment of the skin by a faradic current.

For efficient faradization the skin should be thoroughly dried and a metallic brush or electrode employed. For very sensitive parts, as, for example, the face, the hand of the operator, first thoroughly dried, is to be preferred as an electrode.

Skin, Human, Electric Resistance of — —The electric resistance offered by the skin of the human body.

The electric resistance of the skin is subject to marked differences in different parts of the body, where its thickness or continuity varies. It varies still more with variations in its condition of moisture. Even in the same individual the resistance varies materially under apparently similar conditions.

Sleeve, Insulating — —A tube of treated paper or other insulating material, provided

for covering a splice in an insulated conductor.

Sleeve Joint.—(See *Joint, Sleeve.*)

Sleeve, Lead — —A lead tube provided for making a joint in a lead-covered cable.

Sled.—The sliding contacts drawn after a moving electric railway car through the slotted underground conduit containing the wires or conductors from which the driving current is taken.

Slide Bridge.—(See *Bridge, Electric, Slide Form of.*)

Slide, Resistance — —A rheostat, in which the separate resistances or coils are placed in or removed from a circuit by means of a sliding contact or key.

Apparatus employed in telegraphy for charging a conductor to a given fraction of the maximum potential of the battery so as to adjust its charge in order to balance the varying charge of a cable.

The resistance slide consists essentially of a set of resistance coils of high insulation and of equal resistance. Suppose, for example, ten such equal coils to be connected in series, then if connected to the charging battery the potential will vary by one-tenth at the junction between each pair. A condenser, therefore, will be charged to any number of tenths of the potential of the charging battery by connecting it at suitable points.

A second set of coils of equal resistance is arranged so as to subdivide any of the lower coils, thus permitting an adjustment to within a hundredth of the potential of the battery.

Slide Wire.—(See *Wire, Slide.*)

Sliding Contact.—(See *Contact, Sliding.*)

Slow-Speed Electric Motor.—(See *Motor, Electric, Slow-Speed.*)

Sluggish Magnet.—(See *Magnet, Sluggish.*)

Small Calorie.—(See *Calorie, Small.*)

Smee Voltaic Cell.—(See *Cell, Voltaic, Smee.*)

Smelting, Electro — —The separation or reduction of metallic substances from their ores by means of electric currents.

Snap Switch.—(See *Switch, Snap*.)

Soaking-In.—A term sometimes employed by telegraphers to represent the gradual penetration of an electric charge by a neighboring dielectric.

An electric displacement occurs in the neighboring dielectric, and produces thereby what is generally called the residual charge.

Soaking-Out.—A term sometimes employed by telegraphers to represent a gradual discharge which occurs in the case of a charged conductor in a neighboring dielectric.

When a condenser, or other similar conductor, is discharged, the discharge is not instantaneous. The charge which soaked in, gradually recovers, or soaks-out.

Socket, Electric Lamp — — A support

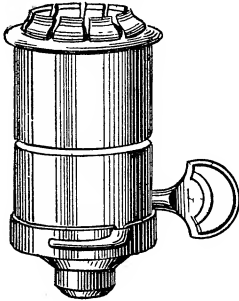

Fig. 503. Lamp Socket.

for the reception of an incandescent electric lamp.

Incandescent lamp sockets are generally made so that the mere insertion of the base of the lamp

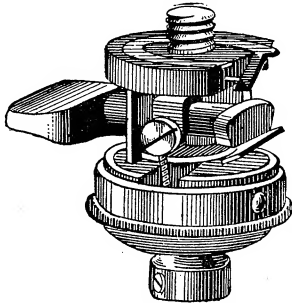

Fig. 504. Lamp Socket.

in the socket completes the connection of the lamp terminals with the terminals of the socket. The

socket terminals are connected with the leads that supply current to the lamp; the removal of the lamp from the socket automatically breaks its circuit. The socket is generally provided with a key for turning the lamp on or off without removing it from the socket.

Figs. 503 and 504 show forms of lamp sockets for incandescent lamps and the details of the key for connecting or disconnecting the lamp with the leads.

Socket, Wall — — A socket placed in a wall and provided with openings for the insertion of a wall plug with which the ends of a flexible twin-lead are connected.

A wall-socket permits the temporary connection of a portable electric lamp, a push button or other device with the conductor or lead.

Soft-Drawn Copper Wire.—(See *Wire, Copper, Soft-Drawn*.)

Soldering, Electric — — A process for obtaining metallic joints, in which heat generated by the electric current is used to melt the solder in the place of ordinary heat.

Solenoid.—A cylindrical coil of wire the convolutions of which are circular.

An electro-magnetic helix. (See *Solenoid, Electro-Magnetic, or Electro-Magnetic Helix*.)

A solenoid is termed dextrorsal or sinistrorsal according to the direction in which its wire is wound. (See *Solenoid, Dextrorsal, Solenoid, Sinistrorsal*.)

Solenoid Core.—The core, usually of soft iron, placed within a solenoid and magnetized by the magnetic field of the current passing through the solenoid.

The soft iron core of a solenoid differs from that of an electro-magnet in the fact that the core of the solenoid is *movable*, while that of the electro-magnet is fixed. (See *Magnet, Electro*.)

In order to obtain a nearly uniform pull in its various positions in the solenoid, the soft iron cores are made of a shape which insures a greater mass of metal towards the middle of the core. (See *Bars, Krizik's*.)

Solenoid, Dextrorsal — — A solenoid in which the winding is right-handed. (See *Solenoid, Practical*.)

Solenoid, Electro-Magnetic, or Electro-Magnetic Helix — — The name given to

a cylindrical coil of wire, each of the convolutions of which is circular.

A circuit bent in the form of a helix, supported at its two extremities, as shown in Fig. 505, and traversed by an electric current, will move into the magnetic meridian of the place, and, if free to move in a vertical plane, will come to rest in the line of the magnetic inclination or dip of the place.

A solenoid traversed by an electric current acquires thereby all the properties of a magnet, and is attracted and repelled by other magnets. Its poles are situated at the ends of the cylinder on which the solenoid may be supposed to be wound.

Solenoid, Ideal — —A solenoid consisting of a cylinder built up of a number of true circular currents, with all faces of like polarity turned in the same direction and entirely independent of one another.

The practical solenoid differs from the ideal solenoid in that the successive circular circuits or currents are all connected with one another in series.

The polarity of a solenoid depends on the direction of the current as regards the direction in which the solenoid is wound.

This solenoid is sometimes called an electro-magnetic solenoid or helix, in order to distinguish

move, will come to rest in the plane of the magnetic meridian when traversed by an electric current.

It will also be attracted or repelled by the approach of a dissimilar or similar magnet pole respectively, as shown in Fig. 505.

Solenoid, Left-Handed — —A sinistrorsal solenoid or one in which the winding is left-handed. (See *Solenoid, Practical*.)

Solenoid, Magnetic — —A spiral coil of wire which acts like a magnet when an electric current passes through it.

The magnetic solenoid must be distinguished from a solenoidal magnet. (See *Magnet, Solenoidal*. *Solenoid, Electro-Magnetic*, or *Electro-Magnetic Helix*.)

Solenoid, Practical — —The name applied to the ordinary solenoid in order to distinguish it from the ideal solenoid. (See *Solenoid, Ideal*.)

A *Practical Solenoid* consists, as shown in Figs.

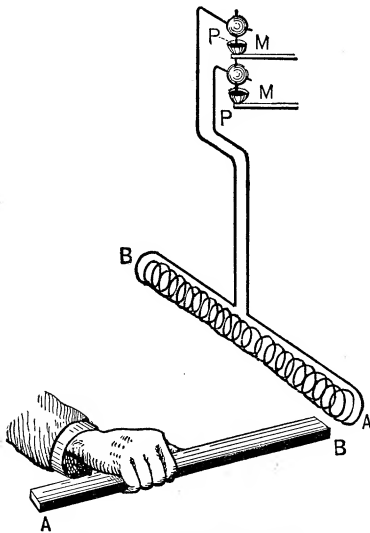

Fig. 505. Practical Solenoid.

it from a solenoidal magnet. (See *Magnet, Solenoidal*.)

A solenoid, if suspended so as to be free to

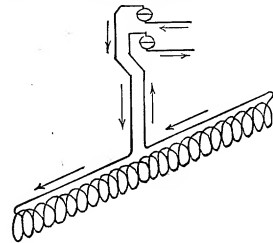

Fig. 506. Practical Solenoid.

move, will come to rest in the plane of the magnetic meridian when traversed by an electric current.

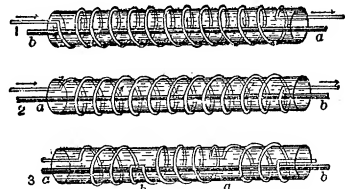

Fig. 507. Right-Handed Helix. Fig. 508. Left-Handed Helix. Fig. 509. Helix, with Consequent Poles.

The polarity of the solenoid depends on the direction of the current, and therefore on the direction of winding. In any solenoid, however, the polarity may be reversed by reversing the direction of the current. (See *Magnet, Electro*.)

A *Right-Handed*, or *Dextrorsal Solenoid*, is one wound in the direction shown in Fig. 507 at 1.

A *Left-Handed, or Sinistrorsal Solenoid*, is one wound in the direction shown in Fig. 508 at 2.

The solenoid shown in Fig. 509 at 3, is wound so as to produce *consequent poles*. (See *Poles, Consequent*.)

Solenoid, Right-Handed — —A dextrorsal solenoid, the winding in which is right-handed. (See *Solenoid, Practical*.)

Solenoid, Sinistrorsal — —A solenoid in which the winding is left-handed. (See *Solenoid, Practical*.)

Solenoidal.—Pertaining to a solenoid.

Solid Angle.—(See *Angle, Solid*.)

Solid Line.—(See *Line, Solid*.)

Solution.—A liquid in which another substance, generally a solid, is dissolved.

The liquid may contain either a solid, another liquid, or a gas.

Solution, Bain's Printing — —The solution used in Bain's chemical telegraph.

Bain's solution is made by mixing together one part of a saturated solution of potassium ferrocyanide, with two parts of water.

Solution, Battery — —The exciting liquid for voltaic cells. (See *Cell, Voltaic*.)

Solution, Chemical, Bain's — —A solution employed in connection with Bain's recording telegraph. (See *Recorder, Chemical, Bain's*.)

Solution, Quicking — —A solution of a salt of mercury, in which objects to be electro-plated are dipped after cleansing, just before being placed in the plating bath.

If the articles have been properly cleansed, immersion in the quicking solution will cover them with a uniform, silver-like coating, which will insure an adherent, uniform coating in the plating bath.

Solution, Saturated — —A solution in which as much of the solid or other substance has been dissolved in the liquid as it will take at a given temperature.

Solution, Super-Saturation of — —The condition assumed by a warmed saturated solution of a salt, when placed in a closed vessel out of contact with the air, and allowed to cool without being shaken.

Under the above circumstances the solution may be cooled without depositing any crystals.

Such a solution is said to be super-saturated. It will immediately deposit crystals if a crystal of the salt dissolved or a crystal of an isomorphous salt be dropped in the solution, or often if merely shaken.

It is important in standard voltaic cells in which zinc sulphate is used, that the solution be saturated but not super-saturated.

Sonometer, Hughes' — —An apparatus for determining the amount of inductive disturbance in an induction balance, by comparing the sounds heard in a telephone, as a result of such induction, with the sounds heard in the same telephone under circumstances in which the amount of disturbance is directly measurable.

An apparatus devised by Professor Hughes to be used in connection with the induction balance, in order to measure the amount of disturbance of balance produced therein in any particular case.

Sonorescence.—A term proposed for the sounds produced when a piece of vulcanite or any other solid substance is exposed to a rapid succession of flashes of light. (See *Photophone*.)

Sound.—The sensation produced on the brain, through the ear, by the vibrations of a sonorous body.

The sound waves that are capable of producing the sensation of sound on the brain through the ear.

The word sound is therefore used in science in two distinct senses, viz.:

(1.) *Subjectively*, as the sensation produced by the vibrations of a sonorous body.

(2.) *Objectively*, as the waves or vibrations that are capable of producing the sensation of sound.

Sound is transmitted from the vibrating body to the ear of the hearer by means of alternate to-and-fro motions in the air, occurring in every direction around the vibrating body and forming spherical waves called *waves of condensation and rarefaction*. Unlike light and heat, these waves require a tangible medium such as air to transmit them.

Sound, therefore, is not propagated in a vacuum. The vibrations of sound are *longitudinal*, that is, the to-and-fro motions occur in the same direction as that in which the sound is traveling. The vibrations of light are *transverse*,

that is, the to and-fro motions are at right angles to the direction in which the light is traveling.

Sound.—(Objectively.) The waves in the air or other medium which produce the sensation of sound.

Sound.—(Subjectively.) The effect produced on the ear by a vibrating body.

Sound, Absorption of — —Acoustic absorption. (See *Absorption, Acoustic.*)

Sound, Characteristics of — —The peculiarities that enable different musical sounds to be distinguished from one another.

The characteristics of musical sounds are:

(1.) The *Tone or Pitch*, according to which a sound is either grave or shrill.

(2.) The *Intensity or Loudness*, according to which a sound is either loud or feeble.

(3.) The *Quality or Timbre*, the peculiarity which enables us to distinguish between two sounds of the same pitch and intensity, but sounded on different instruments, as for example, on a flute and on a piano.

Sound, Quality or Timbre of — —That peculiarity of a musical note which enables us to distinguish it from another musical note of the same tone or pitch, and of the same intensity or loudness, but sounded on another instrument.

The middle C, for example, of a pianoforte, is readily distinguishable from the same note on a flute, or on a violin; that is to say, its quality is different. The differences in the quality of musical sounds are caused by the admixture of additional sounds called *overtones* which are always associated with any musical sound.

Briefly, nearly all so-called simple musical sounds are in reality chords or assemblages of a number of different musical sounds.

In the case of the many different notes that are present in an apparently simple note or tone, one of the notes is far louder than all the others and is called the *fundamental tone* or note, and is what is recognized by the ear as the note proper. The others are called the *overtones*. The overtones are too feeble to be heard very distinctly, but their presence gives to the fundamental note its own peculiar quality. In the case of a note sounded on the flute, these overtones are different either in number or in their relative intensities from the same note sounded on another instru-

ment. Their fundamental tones, however, are the same.

The peculiarities which enable us to distinguish the voice of one speaker or singer from another are due to the presence of these overtones. The overtones must be correctly reproduced by the diaphragm of the telephone, or phonograph, graphophone, or gramophone, if the articulate speech is to be correctly reproduced with all its characteristic peculiarities.

Sounder, Morse Telegraphic — —An electro-magnet which produces audible sounds by the movements of a lever attached to the armature of the magnet.

The Morse sounder has now almost entirely supplanted the paper recorder or register. On short lines it is placed directly in the telegraphic circuit. On long lines it is operated by a *local battery*, thrown into or out of the action by the *relay*. (See *Relay.*)

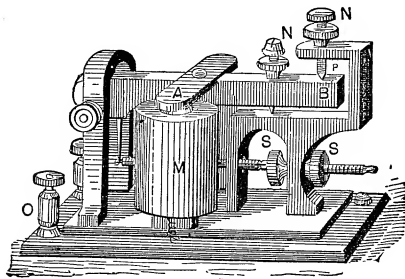

Fig. 510. Morse Sounder.

The Morse sounder, shown in Fig. 510, consists of an upright electro-magnet M, whose soft iron armature A, is rigidly attached to the striking lever B, working in adjustable screw pivots as shown. The free end of the lever is limited in its strokes by two set screws N, N. The lower of these screws is set so as to limit the approach of the armature A, to the poles of the electro-magnet; the upper screw is set so as to give the end B, sufficient play to produce a loud sound. A retractile spring, attached to the striking lever near its pivoted end, and provided with regulating screw S S, pulls the lever back when the current ceases to flow through M.

The dots and dashes of the Morse alphabet are reproduced by the sounder, as audible signals, that are distinguished by the operator by means of the different sounds produced by the up and down stroke of the lever as well as by the differ-

ence in the intervals of time between the successive signals.

Another form of telegraphic sounder, similar in its general construction to that already described, is shown in Fig. 511.

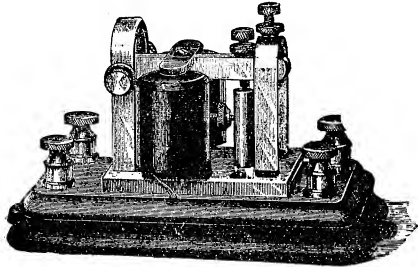

Fig. 511. Telegraphic Sounder.

Sounder, Repeating — —A telegraphic sounder which repeats the telegraphic dispatch into another circuit.

Sounds, Magnetic — —Faint clicks heard on the magnetization of a readily magnetizable substance.

One of the earlier forms of Reis' telephone, operated by means of a rapid succession of these faint magnetic sounds.

Source, Electric — —Any arrangement capable of maintaining a difference of potential or an electromotive force.

The following are the more important electric sources, arranged according to the character of the energy which is converted into electric energy.

ELECTRIC SOURCES.

- | | | |
|---|---|-----------------------------|
| 1. Voltaic Cell or Primary Battery. | } | Chemical Potential Energy. |
| 2. Charged Storage Cell or Secondary Battery. | | |
| 3. Thermo Cell or Thermo Battery. | } | Radiant Energy. |
| 4. Selenium Cell or Selenium Battery. | | |
| 5. Magneto - Electric Machine. | } | Mechanical Energy. |
| 6. Dynamo-Electric Machine. | | |
| 7. Frictional Electric Machine. | | |
| 8. Electrostatic Induction Machine. | } | Heat and Mechanical Energy. |
| 9. Magneto-Electric Telephone Transmitter. | | |
| 10. Pyromagnetic Generator. | } | Vital Energy. |
| 11. Animal or Plant..... | | |

Sources, Multiple-Arc-Connected — — A term sometimes applied to sources connected in multiple. (See *Sources, Multiple-Connected.*)

Sources, Multiple-Connected — —The connection of a number of separate sources so as to form a single source by joining the positive poles of all the separate sources to a single positive lead or conductor, and all the negative poles to a single negative lead or conductor.

The multiple connection of sources results in each of the sources discharging its current into the main conductor in a direction parallel to that of the other sources.

The electromotive force in the same is that of any single source, but the resistance of the combined source decreases with each source added. Supposing the resistance of each source be the same, then if ten such sources are connected in multiple-arc, the resistance of the combined source is but one-tenth the resistance of a single source. (See *Circuit, Multiple.*)

Sources are combined in multiple-arc whenever the current furnished by the separate sources is insufficient to properly operate the electro-receptive or translating device with which it is connected.

Sources, Multiple-Series-Connected — —The connection of a number of separate sources so as to form a single source by connecting a number of the sources in groups in series, and joining these groups together in multiple-arc.

The battery of sources obtained by connecting a number of separate sources in multiple-series will have an electromotive force equal to the sum of the separate electromotive forces of the sources connected in any of the separate series-connected groups.

The current produced will be greater in proportion to the number of separate groups in parallel. The internal resistance will be increased in proportion to the number of coils in series, and decreased in proportion to the number of groups in multiple-arc or parallel.

Sources are connected in *multiple-series* when both the electromotive force and the current of any single source are insufficient to operate the electro-receptive or translating device. (See *Circuit, Multiple-Series.*)

Sources, Parallel-Connected — —A term sometimes applied to multiple-connected sources. (See *Sources, Multiple-Connected.*)

Sources, Series-Connected — —The connection of a number of separate electric sources so as to form a single source, in which the separate sources are placed in a single line or circuit by so connecting their opposite poles that the current produced in each passes successively through each of the sources.

The series-connection of sources results in an electromotive force equal to the sum of the separate electromotive forces produced by each source—that is, a rise of potential occurs with each source added. This connection increases the resistance of the circuit by the amount of the resistance of each source introduced into the circuit. The value of the resulting current depends on the total electromotive force and resistance of the series-connected sources.

Sources are connected in series when the electromotive force furnished by a single source is insufficient for the character of work required to be done. (See *Circuit, Series.*)

Sources, Series-Multiple-Connected — —The connection of a number of separate electric sources, so as to form a single source, in which the separate sources are connected in a number of separate multiple groups or circuits, and these groups or circuits separately connected together in series. (See *Circuit, Series-Multiple.*)

Southern Light.—A name sometimes given to the Aurora Australis. (See *Aurora Australis.*)

Space, Clearance — —The space between the revolving armature of a dynamo-electric machine, or electric motor, and the polar faces of the pole pieces.

Space, Dark, Crookes' — —A dark space surrounding the negative electrode in a rarefied space through which electric discharges are passing.

Crookes' dark space lies immediately between the negative electrode and its glow or luminous discharge. It differs, therefore, from Faraday's dark space, which lies between the luminous discharges of the negative and positive electrodes.

The radius of Crookes' dark space increases with the degree of exhaustion. It varies also with the character of the residual gas, with the temperature of the negative electrode, and somewhat with the intensity of the spark. When the vacuum becomes sufficiently high, the dark space fills the entire tube through which the discharges are passing.

Crookes has found that in the case of substances that become phosphorescent under the electric discharge, phosphorescence best takes place when the body is placed on the boundary of the dark space.

Space, Dark, Faraday's — —The gap in the continuity of the luminous discharges that occurs between the glow of the positive and negative electrodes.

Faraday's dark space is seen in a partially exhausted tube through which the discharges of an induction coil are passing. It occurs in as low a vacuum as 6 millimetres of mercury. As the vacuum becomes higher, the length of the dark space increases.

Space, Inter-Air — —A term sometimes employed for the air space between the outer surface of the revolving armature of a dynamo-electric machine and the adjacent faces of the pole pieces. (See *Space, Clearance.*)

Space, Interferric — —A term sometimes used for air gap. (See *Gap, Air.*)

Span Wire.—(See *Wire, Span.*)

Spark Coil.—(See *Coil, Spark.*)

Spark Gap.—(See *Gap, Spark.*)

Spark, Length of — —The length of spark that passes between two charged conductors depends :

- (1.) On the difference of potential between them.
- (2.) On the character of the gaseous medium that separates the two conductors.
- (3.) On the density or pressure of the gaseous medium between the conductors.

Up to a certain pressure, a decrease in the density causes an increase in the length of the distance the spark will pass. When this limit is reached, a further decrease of density decreases the length of spark. A high vacuum prevents the passage of a spark even under great differences of potential.

(4.) On the kind of material that forms the electrodes between which the charges pass.

(5.) On the shape of the charged conductor.

(6.) On the direction of the current.

Sparks from the prime conductor are denser and more powerful than those from the negative conductor.

It will be observed that the length of the spark practically depends mainly on two circumstances, viz., on the differences of potential of the opposite charges, and the conducting power of the medium that separates the two bodies.

Spark, T-Shaped — —A variety of three-branched spark obtained by the discharge of a Leyden jar through a peculiar form of induction coil. (See *Spark, Three-Branched*.)

Spark, Three-Branched — —A peculiar form of branched spark obtained by the discharge of a Leyden jar through a peculiar form of induction coil.

The three-branched spark was obtained by Elihu Thomson by the use of the following apparatus: The discharges of a Leyden jar, charged by a Töpler-Holtz machine, were sent through an induction coil, the primary and secondary of which

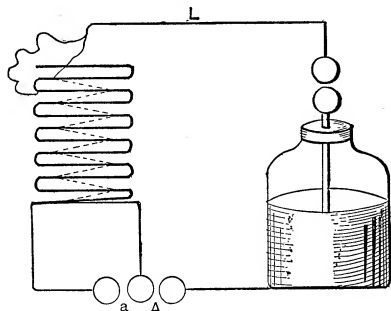

Fig. 512. Apparatus for Three-Branched Sparks.

were of few turns. The circuit connections were as shown in Figs. 512 and 513, and the apparatus is described by Thomson as follows:

“A double coil was made, Fig. 512, in which the inner turns were about twelve and the outer turns twenty. These were kept separate from each other and a branch wire taken from the line and slid from point to point on the outer wire enabled the effective length of the same to be adjusted. The inner coil was connected through a small spark gap, as at A, to the outer coating of a Leyden jar, while the wire L, was brought near the pole of the jar, which was continually being

charged from a Töpler-Holtz machine. The discharge, in passing from the knob of the jar to the wire L, representing the line, passed by the

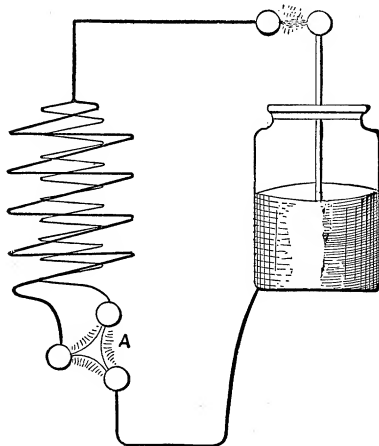

Fig. 513. Apparatus for T and Y Shaped Sparks.

inner coil. When a certain length of the outer coil was employed, only a very short, almost imperceptible spark was obtainable at a. If the balance of the turns were disturbed by including more or less than the proper number of the outer turns, not only did a vigorous spark occur, but the gap at a, could be quite considerably extended, in accordance with the amount of departure taken from the proper number of turns required to produce the balance. This experiment indicates that it is possible to make a selective path for the Leyden jar discharge, and to have a structure so proportioned that the discharges reaching line will pass to earth without

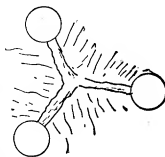

Fig. 514. Three-Branched Sparks.

tending to go through the circuit of the dynamo. The action is apparently due to a balance of electromotive forces such that the discharge which tends to pass from the line in going to earth induces in the coil connected to the dynamo a counter electromotive force which nearly wipes out the potential of the discharge before it reaches the dynamo. This balance of inductive effects is certainly very striking, and once obtained, it is disturbed, as, in the experiments, by changing the relative lengths of the coils in inductive relation through so small an amount as an inch or two.

“It may be mentioned here that some curious

effects of spark were obtained in these experiments. When a disturbance of the balance exists and a spark is obtained at a, the character of the spark is different from that of the Leyden jar discharge. It appears to be less luminous, the noise less sharp, and its color would indicate a greater power of volatilizing metal and perhaps a greater duration. It is in part, no doubt, due to a current local to the coils in series with one another.

"Another curious effect was the production of T-shaped and Y-shaped sparks, or three-branched sparks (such as are shown in Figs. 513 and 514.)"

"These were obtained by separating the electrodes at A, an inch and a half or thereabouts, and bringing the third electrode from the outer coil to the position shown in Fig. 513. The discharges were now obtained as before from the charged jar. In this case the discharge appears to split and unite in air, producing the curious shaped sparks shown. It would seem that to obtain these effects—particularly the sparks which were three-branched from a common point in the centre between the discharge electrodes—the dielectric air must break down simultaneously between the three electrodes. It would easily explain the T-shapes to assume the straight part above to form first, and the cross or transverse spark to strike from the side of this spark to the third electrode."

Spark Tube.—(See *Tube, Spark*.)

Spark, Wipe — —In an electric gas-lighting pendant burner, a spark obtained from a spark coil by the wiping contact of a spring, moved by the pulling of the pendant. (See *Burner, Ratchet-Pendant, Electric*.)

Spark, Y-Shaped — —A variety of three-branched spark obtained by the discharge of a Leyden jar through a peculiar form of induction coil. (See *Spark, Three-Branched*.)

Sparking Discharge.—(See *Discharge, Disruptive*.)

Sparking Distance.—(See *Distance, Sparking*.)

Sparking, Line of Least — —The line on a commutator cylinder of a dynamo connecting the points of contact of the collecting brushes where the sparking is a minimum.

In some forms of dynamos the line of least

sparkling lies parallel to the lines of magnetic force of the field.

In most forms, however, it is at right angles to such lines. The exact position of all these lines is changed by the angular lead of the brushes. (See *Lead, Angle of*.)

Sparking of Dynamo-Electric Machine.—(See *Machine, Dynamo-Electric, Sparking of*.)

Spar Torpedo.—(See *Torpedo, Spar*.)

Spasmodic Governor.—(See *Governor, Spasmodic*.)

Speaking-Tube Annunciator.—(See *Annunciator, Oral or Speaking-Tube*.)

Speaking-Tube Mouth Piece, Electric Alarm — —A mouth piece for a speaking tube, so arranged, that the movement of a pivoted plate covering the mouth piece automatically rings a bell at the other end of the tube.

Specific Conduction Resistance.—(See *Resistance, Specific Conduction*.)

Specific Conductivity.—(See *Conductivity, Specific*.)

Specific Heat.—(See *Heat, Specific*.)

Specific Heat of Electricity.—(See *Electricity, Specific Heat of*.)

Specific Hysteresial Dissipation.—(See *Dissipation, Specific Hysteresial*.)

Specific Inductive Capacity.—(See *Capacity, Specific Inductive*.)

Specific Magnetic Capacity.—(See *Capacity, Specific Magnetic*.)

Specific Magnetic Conductivity.—(See *Conductivity, Specific Magnetic*.)

Specific Magnetic Inductivity.—(See *Inductivity, Specific Magnetic*.)

Specific Resistance.—(See *Resistance, Specific*.)

Specific Resistance of Liquids.—(See *Resistance, Specific, of Liquids*.)

Speech, Articulate — —The successive tones of the human voice that are necessary to produce intelligible words.

The phrase articulate speech refers to the joining or articulation of the successive sounds involved in speech. The receiving diaphragm of a

telephone is caused to reproduce the articulate speech uttered near the transmitting diaphragm.

Speed, Critical, of Compound-Wound Dynamo — — The speed at which both the series and shunt coils of the machine give the same difference of potential when the full load is on the machine, as the shunt coil would if used alone on open-circuit.

Speed Indicator.—(See *Indicator, Speed.*)

Speeding.—Varying the number of revolutions per minute.

The speeding of a dynamo is for the purpose of obtaining the current requisite to properly operate the electro-receptive device placed in its circuit.

Spent Acid.—(See *Acid, Spent.*)

Spent Liquor.—(See *Liquor, Spent.*)

Spherical Armature.—(See *Armature, Spherical.*)

Sphygmogram.—A record made by a sphygmograph. (See *Sphygmograph.*)

Sphygmograph.—An instrument for recording the peculiarities of the normal or abnormal pulse.

Sphygmograph, Electrical — — An instrument for electrically recording the peculiarities of the pulse.

Sphygmophone.—An apparatus in which a microphone is employed for the medical examination of the pulse. (See *Microphone.*)

Spider, Armature — — A light framework or skeleton consisting of a central sleeve or hub keyed to the armature shaft, and provided with a number of radial spokes or arms for fixing or holding the armature core to the dynamo-electric machine.

Spider, Driving — — Radial arms or spokes connected to the armature of a dynamo-electric machine and keyed to the shaft so as to act as a driving wheel for the armature.

Spin, Magnetic — — A term sometimes employed instead of magnetic field.

The term magnetic spin is sometimes used instead of magnetic field because the magnetism is now generally believed to be due to the effects of a rotary motion or spin in the surrounding universal ether.

Spiral, Primary — — The primary of an induction coil or transformer. (See *Transformer, Coil, Induction.*)

Spiral, Roget's — — A suspended wire spiral conveying a strong electric current and devised to show the attractions produced by parallel currents flowing in the same direction.

The lower end of the wire spiral dips into a mercury cup. On the passage of the current, the attraction of the neighboring turns of the spiral for each other shortens the length of the spiral sufficiently to draw it out of the mercury and thus break the circuit. When this occurs the weight of the spiral causes it to fall and again re-establish the circuit. A rapid automatic-make-and-break is thus established, accompanied by a brilliant spark at the mercury surface due to the extra spark on breaking.

Spiral, Secondary — — The secondary coil of an induction coil or transformer. (See *Transformer, Coil, Induction.*)

Splice Box.—(See *Box, Splice.*)

Split Battery.—(See *Battery, Split.*)

Split Lead Tee.—(See *Tee, Split Lead.*)

Spluttering of Arc.—(See *Arc, Spluttering of.*)

Spots, Sun — — Dark spots, varying in number and position, which appear on the face of the sun and are believed by some to be caused by huge vortex motions in the masses of glowing gas that surround the sun's body.

Sun spots occur in greater number at intervals of about every eleven years.

Their occurrence is generally attended with unusual terrestrial magnetic variations. (See *Storm, Magnetic.*)

In the opinion of most astronomers the sun spots mark depressions in the atmosphere of the sun. Their exact causes are unknown, though they appear to be dependent on a local cooling or condensation of the sun's atmosphere.

When observed through a telescope the sun spot appears as a dark region surrounded by a less dark region. Though darker by contrast with the rest of the sun's face, yet such spots are in reality much brighter than the most brilliant arc light. The outline of the sun spot is quite irregular.

Spreading-Out Magnetic Field.—(See *Field, Magnetic, Spreading-Out.*)

Sprengel Mercury Pump.—(See *Pump, Air, Sprengel's Mercurial.*)

Spring Ammeter. — (See *Ammeter, Spring.*)

Spring Contact.—(See *Contact, Spring.*)

Spring, Hold-Off — —A spring which acts to keep one thing away from another in opposition to some force tending to keep it in contact with such a thing.

Spring, Hold-On — —A spring which acts to keep one thing against another in opposition to some force tending to pull it away.

A hold-on spring is sometimes employed in a dynamo-electric machine for the purpose of keeping the collecting brushes in proper pressure against the segments of the commutator.

Spring-Jack.—A device for readily inserting a loop in a main electric circuit. The spring-jack is generally used in connection with a multiple switch board. (See *Board, Multiple Switch.*)

Spring-Jack Cut-Out.—(See *Cut-Out, Spring-Jack.*)

Spurious Hall Effect.—(See *Effect, Hall, Spurious.*)

Spurious Resistance.—(See *Resistance, Spurious.*)

Stabile Galvanization.—(See *Galvanization, Stabile.*)

Staggering.—A term sometimes applied to the position of the brushes on a commutator cylinder, in which one brush is placed slightly in advance of the other brush so as to bridge over a break.

When a break occurs in the circuit of the armature wires, the device of staggering the brushes is adopted for temporarily bridging over the break. When a break occurs, the rewinding of the armature is the only radical cure.

Standard Candle.—(See *Candle, Standard.*)

Standard Careel Gas Jet.—(See *Jet, Gas, Careel Standard.*)

Standard, Dynamo — —The supports for the bearings of a dynamo-electric machine.

Standard Earth Quadrant.—(See *Quadrant, Standard.*)

Standard of Self-Induction, Ayrton & Perry's — —(See *Induction, Self, Ayrton & Perry's Standard of.*)

Standard Ohm.—(See *Ohm, Standard.*)

Standard, Pentane — —A standard source of light used in photometric measurements, in place of a Methven screen.

The pentane standard is constructed in general in the same manner as the Methven standard. In place, however, of ordinary coal gas, a mixture of pentane and air is used. Pentane is a variety of coal oil left after several distillations of ordinary crude oil. It distills at a temperature not greater than 50 degrees centigrade.

The mixture for burning consists of about twenty volumes of air to seven volumes of pentane. A burner of the pentane standard is somewhat similar to the Methven standard, but differs in a number of minor details.

Standard Resistance Coil.—(See *Coil, Resistance, Standard.*)

Standard Size of Electrodes, Erb's — —(See *Electrodes, Erb's Standard Size of.*)

Standard Voltaic Cell.—(See *Cell, Voltaic, Standard.*)

Standard Voltaic Cell, Clark's — —(See *Cell, Voltaic, Standard, Clark's.*)

Standard Voltaic Cell, Clark's, Rayleigh's Form of — —(See *Cell, Voltaic, Standard, Rayleigh's Form of Clark's.*)

Standard Voltaic Cell, Fleming's — —(See *Cell, Voltaic, Standard, Fleming's.*)

Standard Voltaic Cell, Lodge's — —(See *Cell, Voltaic, Standard, Lodge's.*)

Standard Voltaic Cell, Sir William Thomson's — —(See *Cell, Voltaic, Standard, Sir William Thomson's.*)

Standard Wire Gauge.—(See *Gauge, Wire, Standard.*)

Standardizing a Voltaic Cell.—(See *Cell, Voltaic, Standardizing a.*)

Standards, Motor — —A name applied to the supports for the bearings of an electric motor.

State, Allotropic — —A modification of a substance, in which, without changing its chemical composition, it assumes a condition in which many of its physical and chemical properties are different from those it ordinarily possesses.

Thus the element carbon occurs in three widely different allotropic states, viz.:

- (1.) As charcoal, or ordinary carbon;
- (2.) As graphite, or plumbago; and
- (3.) As the diamond.

State, Anelectrotonic — —The condition of decreased functional activity which occurs in a nerve in the neighborhood of the anode or positive terminal of a source to whose influence it is subjected. (See *Anelectrotonus.*)

State, Electrotonic — —A peculiar state supposed by Faraday to exist in a wire or other conductor, whereby differences of potential are produced by means of its movement through a magnetic field.

In his early researches Faraday regarded this state as a necessary condition in which a wire or conductor must exist, prior to its movement through a magnetic field, in order to have a difference of potential produced; but at a later day he abandoned this idea, and explained the true causes of electrodynamic induction. (See *Induction, Electro-Dynamic.*)

The term electrotonic state is to be carefully distinguished from electrotonus, or the change produced in the functional activity of a nerve by an electric current. (See *Electrotonus.*)

State, Kathelectrotonic — —The condition of increased functional activity of a nerve in the neighborhood of the cathode or negative terminal of a source to whose influence it is subjected. (See *Kathelectrotonus.*)

The kathelectrotonic state is one of the states or conditions of electrotonus or altered functional activity produced in a nerve by an electric current. (See *Electrotonus.*)

State, Nascent — —A term used in chemistry to express the state or condition of an elementary atom or radical just liberated from chemical combination, when it possesses chemical affinities or attractions more energetic than afterwards.

According to Grothüss' hypothesis, during the decomposition of a chain of polarized molecules, such for example as in the case of hydrogen sulphate, $H_2 SO_4$, in a zinc-copper voltaic cell, the two atoms of hydrogen H_2 , liberated by the combination of the SO_4 , with an atom of zinc, Zn, possess a stronger affinity for the SO_4 of the molecule next to it, than does its own H_2 , and thus liberates its two atoms of hydrogen, which in turn unite with the SO_4 of the next molecule in the polarized chain, and this continues until the two atoms of hydrogen liberated from the last molecule in the chain are given off at the copper plate. (See *Hypothesis, Grothüss'.*)

The peculiar properties characteristic of the nascent state of elements is doubtless due to the fact that the elements are then in a *free state*, with their *bonds open or unsatisfied*, and therefore possess greater affinities than when they are united in molecules. Thus $H-$, $H-$, or *atomic hydrogen*, should possess different affinities than $H-H$, or *molecular hydrogen*.

State, Passive — —The condition of a metallic substance in which it may be placed in liquids that would ordinarily chemically combine with it, without being attacked or corroded.

It is very doubtful whether metallic bodies can be properly regarded as possessing an actual passive state. Iron, for example, which is one of the metals that is said to be capable of assuming this so-called *passive state*, can be placed in this condition by immersing it for a few moments in concentrated nitric acid, and subsequently washing it. It will then, unlike ordinary iron, neither be attacked by concentrated nitric acid, nor will it precipitate copper from its solutions. This condition is now generally believed to be due to the formation of a thin coating of magnetic oxide on its surface.

Many of the instances of the so-called passive state are simply cases of the well known electrical preservation of metals that form the negative element of a voltaic combination, under which circumstances the positive element only of the

voltaic couple is chemically attacked by the electrolyte. (See *Cell, Voltaic. Metals, Electrical Protection of.*)

State, Permanent, of Charge on Telegraph Line — —The condition of the charge on a telegraph wire when the current reaching the distant end has the same strength as at the sending end.

State, Variable, of Charge of Telegraph Line — —The condition of the charge on a telegraph wire while the strength of the current is increasing up to the full strength in all parts.

The duration of the variable state is directly as the length of the line, the electrostatic capacity and the total resistance. It is increased by leakage, by static capacity and by the effects of the extra current. (See *Currents, Extra.*)

Static Breeze.—(See *Breeze, Static.*)

Static Electricity. — (See *Electricity, Static.*)

Static Energy.—(See *Energy, Static.*)

Static Hysteresis. — (See *Hysteresis, Static.*)

Static Insulation. — (See *Insulation, Static.*)

Static Magnetic Induction.—(See *Induction, Magnetic, Static.*)

Static Shock.—(See *Shock, Static.*)

Statics.—The science which treats of the relations that must exist between the points of application of forces and their direction and intensity, in order that equilibrium may result.

Statics, Electro — —That branch of electric science which treats of the phenomena and measurement of electric charges.

Some of the more important principles of electrostatics are embraced in the following laws:

(1.) Charges of like name, *i. e.*, either positive or negative, repel each other. Charges of unlike name attract each other.

(2.) The forces of attraction or repulsion between two charged bodies are directly proportional to the product of the quantities of electricity possessed by the bodies and inversely proportional to the square of the distance between them.

These laws can be demonstrated by the use of Coulomb's torsion balance. (See *Balance, Coulomb's Torsion.*)

Statics, Magneto — —That branch of magnetism which treats of magnetic attractions and repulsions, the distribution of lines of magnetic force and other facts regarding fixed magnets.

Station, Central — —A station, centrally located, from which electricity for light or power is distributed by a series of conductors radiating therefrom.

Station, Distant — —A term applied by an operator to the distant end of the line in order to distinguish it from his own end.

Station, Distributing — —A station from which electricity is distributed.

A central station.

Station, Home — —A term applied by an operator to his end of the line, in order to distinguish it from the other or distant station.

Station, Transforming — —In a system of distribution by transformers or converters a station where a number of transformers are placed, in order to supply a group of houses in the neighborhood. (See *Transformer, Electricity, Distribution of, by Alternating Currents.*)

Stationary Floor Key.—(See *Key, Stationary Floor.*)

Stationary Torpedo.—(See *Torpedo, Stationary.*)

Stay Rods, Telegraphic — —Metal rods attached to a telegraph pole, and securely fastened in the ground in order to counteract the effects of a pull or tension on the poles. (See *Pole, Telegraphic.*)

Stay rods should be used in all exposed situations, or where the poles are exposed to severe strains.

Steady Current.—(See *Current, Steady.*)

Stearns' Relay Shunt.—(See *Shunt, Relay, Stearns'.*)

Steel, Qualities of, Requisite for Magnetization — — Qualities which must be

possessed by steel in order to permit it to permanently retain a considerable magnetization.

For the purposes of permanent magnetization steel should possess the following qualities:

It should be hard and fine grained. Hard cast steel answers the purpose very well. Scoresby showed that an intimate relation exists between the quality of the iron from which the steel is made, and the ability of the steel to take and retain considerable magnetism.

The steel should be hardened as high as possible and the temper afterwards drawn by heat to a violet-straw color. Practice is not uniform in this respect, the exact color varying with the quality of the steel.

An admixture with the steel of about $\frac{3}{100}$ of one per cent. of tungsten is said to increase its magnetic powers.

Cast steel is not generally employed for magnets, wrought steel being generally preferred.

Step-by-Step, or Dial Telegraphy.—(See *Telegraphy, Step-by-Step.*)

Step-Down Transformer.—(See *Transformer, Step-Down.*)

Step-Up Transformer.—(See *Transformer, Step-Up.*)

Sterilization, Electric — —Sterilizing a solution by depriving it of whatever germs it may contain by means of electrical currents.

The following experiments were recently made on sterilization by means of electric currents: The fluid, with the culture, was placed in a glass test tube, wound about with a wire coil connected either with a dynamo or accumulator or other electric source. Some increase in temperature was made, but never over 98° Fahr. When a current 1.25 volts, 2.5 ampères passed, a complete sterilization of *Micrococcus Prodigiosus* occurred at the end of twenty-four hours.

Blood and water containing pathogenic germs was sterilized in five to thirty minutes. The above described effects would appear to be magnetic rather than electric.

Sticking.—A word applied by telegraphers to the failure of the positive pole relay armature to leave the magnet pole on the cessation of the current.

In telegraphy, when from any cause a circuit is imperfectly broken by an operator's key, or at

the points of contact of a relay or other instrument, such failure is called sticking. When an arc is formed at the points of a relay where the local circuit is made and broken, the relay "sticks." The arc is caused by burning of the platinum points. *Sticking* may be a result of a too weak retractile spring.

Stone, Hercules — —A name given by the ancients to the lodestone. (See *Lodestone.*)

Stool, Insulating — —A stool provided with insulating supports of vulcanite or other insulator, employed to afford a ready insulating stand or support.

Stop, Limiting — —A stop set so as to limit the motion of an electrically vibrating or oscillating bar to any predetermined extent.

Such limiting stops are common on telegraphic and various other electrical apparatus.

Stopping-Off.—A process employed in electro-plating, in which a metallic article, already electro-plated over its entire surface, is electro-plated with another metal over certain parts only.

The process of stopping-off consists of covering the parts which are to receive the metallic coating, with various stopping-off varnishes. By this means articles can be electro-plated on parts of their surfaces with gold and on the remainder with silver. The whole surface is first silvered and the portions intended to be afterwards gilded are then stopped off and the object placed in the gilding bath.

Stopping-Off Varnish.—(See *Varnish, Stopping-Off.*)

Storage Battery.—(See *Battery, Storage.*)

Storage Capacity of Secondary Cell.—(See *Cell, Secondary or Storage, Capacity of.*)

Storage Cell.—(See *Cell, Storage.*)

Storage of Electricity.—(See *Electricity, Storage of.*)

Storm, Auroral — —A term sometimes employed to express an unusual prevalence of auroras.

Storm, Electric — —An unusual condition of the atmosphere as regards the quantity of its free electricity.

A thunder storm is a variety of electric storm. (See *Storm, Thunder.*)

Storm, Magnetic — —Irregularities occurring in the distribution of the earth's magnetism, affecting the magnetic declination, dip, and intensity.

Magnetic storms have been observed to accompany auroral displays, and to be coincident with the occurrence of *sun spots*, or unusual outbursts of solar activity.

The coincidence of magnetic storms and outbursts of solar activity is unquestioned. Wolf, of Zurich, has shown by a comparison of numerous observations of sun spots, the unquestioned correspondence, in the times of their greatest activity, which occur every 11.1 years, with the time of occurrence of an unusual number of sun spots. He has placed these results in the form of curves. Those shown in Fig. 515 are taken from observations at Paris and Prague. The full lines represent the periods of sun spots. The dotted lines the periods of magnetic storms.

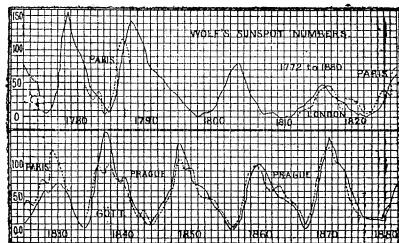

Fig. 515. Wolf's Sun Spot Numbers.

Storm, Thunder — —A storm during which electrical discharges accompanied by thunder take place between two clouds or between a cloud and the earth. (See *Electricity, Atmospheric. Storms, Thunder, Geographical Distribution of.*)

Storms, Thunder, Geographical Distribution of — —The following general facts as to the geographical distribution of thunder storms, show the intimate relation between the frequency of thunder storms and the time and place of the condensation of vapor.

(1.) Thunder storms seldom, if ever, occur in the polar regions.

This is probably because the rainfall in the

polar regions results from the condensation of the vapor that was formed in the equatorial or temperate regions, so that a considerable time elapses between the evaporation and condensation.

(2.) Thunder storms seldom, if ever, occur in rainless districts, owing probably to the absence of the condensation of vapor.

(3.) Thunder storms are most frequent and violent in the equatorial regions, where the rainfall results from the condensation of the vapor by the action of ascending currents, conveying the vapor almost immediately after its formation into the upper and colder regions of the atmosphere.

(4.) Thunder storms occur in regions beyond the tropics, at those seasons of the year when the rainfall results from the condensation of the vapor shortly after the time of its formation, viz., in the temperate zones in the hotter parts of the year.

Straight-Line Trolley Hanger.—(See *Hanger, Straight-Line Trolley.*)

Straightaway Bunched Cable.—(See *Cable, Bunched, Straightaway.*)

Strain, Dielectric — —The strained condition in which the glass, or other dielectric of a condenser, is placed by the charging of the condenser.

The deformation of a body under the influence of a stress. (See *Stress.*)

The *stress* in this case, *i. e.*, the force producing the deformation or *strain*, is the attraction of the opposite charges. This stress, in the case of a Leyden jar, is often sufficiently great to cause a rupture of the glass.

Strain, Electro-Magnetic — —The deformation produced by an electro-magnetic stress. (See *Stress, Electro-Magnetic.*)

Strain, Electrostatic, Optical — —A strain or deformation produced in a plate of glass, or other transparent solid, by subjecting it to the stress of an electrostatic field. (See *Stress, Electrostatic.*)

To obtain the electrostatic stress, holes are drilled in the plate of glass, and wires from a *Holtz machine* or *induction coil* placed therein, the wires being separated by a thin layer of glass.

The glass, on being traversed by a beam of plane polarized light, rotates the plane of polarization of the light in the same direction as the glass would if subjected to a *strain in the direc-*

tion of the lines of electric force. (See *Rotation, Magneto-Optic.*)

Strain, Magnetic — —The deformation produced in the air-gap between two dissimilar magnetic poles, or in any substance placed therein, by the stress of the lines of magnetic force bridging such gap.

Strain, Optical — —A deformation or alteration of volume produced in a plate of glass, or other transparent medium, by the action of any stress. (See *Strain, Electro-Magnetic, Strain, Electrostatic, Optical.*)

Strain, Optical Electro-Magnetic — —A strain produced in a plate of glass or other transparent medium by placing it in a magnetic field. (See *Stress, Electro-Magnetic, Rotation, Magneto-Optic.*)

Optical strain, whether electrostatic or magnetic, or even mechanical, often causes a medium to acquire the power of *double refraction* or *rotary polarization*. (See *Refraction, Double, Electric, Rotation, Magneto-Optic.*)

Stranded Core of Cable.—(See *Core, Stranded, of Cable.*)

Stranded Line.—(See *Line, Stranded.*)

Strap Copper.—(See *Copper, Strap.*)

Straps and Climbers.—Devices employed by linemen for climbing wooden telegraph poles.

Stratham's Electric Fuse.—(See *Fuse, Electric, Stratham's.*)

Stratification Tube.—(See *Tube, Stratification.*)

Stratified Discharge.—(See *Discharge, Stratified.*)

Stray Field.—(See *Field, Magnetic, Stray.*)

Stray Power.—(See *Power, Stray.*)

Stream-Lines of an Escaping Fluid.—Lines which show the actual path of the particles of an escaping fluid.

When the escape has reached a steady condition, the stream-lines correspond to the flow lines.

Streamers.—Pillars or parallel flashing columns of light frequently seen during the prevalence of an aurora. (See *Aurora Borealis.*)

Streamers, Auroral — —A term sometimes applied to the flashing columns or pillars of light that are thrown out in the shape of streams, from portions of the sky during the prevalence of an aurora. (See *Aurora Borealis.*)

Streaming Discharge.—(See *Discharge, Streaming.*)

Streamlets, Current — —A theoretical conception of a series of parallel current streams or current filaments, flowing through a solid conductor.

In the case of uniform distribution of an electric current where the current density is the same for all areas of cross-section, these current streamlets are all of the same strength.

In the case of rapidly alternating currents, however, the current streamlets are of greater strength near the surface. When the rate of alternation is sufficiently great, they are almost entirely absent at the central parts.

The conception of current streamlets is made in order to account for the increase in the resistance of a solid conductor through which rapidly alternating currents of electricity are passing. (See *Currents, Simple-Periodic.*)

Streams, Convection — —Streams of electrified air or other gaseous or vaporous particles given off from the pointed ends of charged, insulated conductors. (See *Convection, Electric.*)

Street Mains.—(See *Main, Street.*)

Street Service.—(See *Service, Street.*)

Strength, Field — —The intensity or total flux of magnetism of a dynamo.

This term is also sometimes roughly used for the current strength in the field magnet circuit of a dynamo-electric machine.

Strength of Current.—(See *Current Strength.*)

Strength of Magnetic Field.—(See *Field, Magnetic, Strength of.*)

Strength of Magnetism.—(See *Magnetism, Strength of.*)

Stress.—The pressure, pull, or other force producing a deformation or strain.

Stress, Dielectric — —The force producing the deformation or strain in a dielectric.

A dielectric strain, in the case of a Leyden jar or condenser, is sometimes sufficiently great to pierce the dielectric.

Stress, Electro-Magnetic — —The force or pressure in a magnetic field, which produces a strain or deformation in a piece of glass or other similar substance placed therein. (See *Strain, Optical Electro-Magnetic*.)

Stress, Electrostatic — —The force or pressure in an electrostatic field, which produces strain or deformation in a piece of glass or other substance placed therein. (See *Strain, Electrostatic, Optical*.)

Stress, Energy of — —A term sometimes used in place of potential energy. (See *Energy, Potential*.)

Stress, Magnetic — —The force acting to produce a strain in the air-gap between two dissimilar magnet poles by the action of the lines of magnetic force, bridging such air gap.

Striæ, Electric — —Parallel streaked bands, consisting of alternate light and dark spaces, produced in tubes containing low vacua, by the passage of rapidly alternating currents through them. (See *Tube, Stratification*.)

Strip, Safety — —A strip or bar used as a safety fuse. (See *Fuse, Safety*.)

Stripping.—Dissolving the metal coating from a silver-plated or other metal-plated article.

The object of the "stripping" process is to recover silver from imperfectly plated ware, or from old ware which is to be replated.

Stripping of silver is accomplished either in the cold or by aid of heat, by the use of the following solutions, viz.:

Concentrated sulphuric acid,
(Baumé, 66 degrees).....100 parts.
Concentrated nitric acid,
(Baumé, 40 degrees)..... 10 "

The objects are suspended in this liquid, which, provided it be not diluted with water, possesses the property of dissolving the silver without touching the metal underneath.

Stripping Baths.—(See *Bath, Stripping*.)

Stripping Liquid.—(See *Liquid, Stripping*.)

Stroke, Lightning — —A disruptive discharge between two oppositely charged clouds, or between a cloud and the earth. (See *Discharge, Disruptive*.)

Stroke, Lightning, Back or Return — —An electric shock, caused by an induced charge, produced by the discharge of a lightning flash.

The shock is not caused by the lightning flash itself, but by a charge which is induced in neighboring conductors by the discharge. These induced effects are, in fact, effects of electro-dynamic induction. (See *Induction, Electro-Dynamic*.) A similar effect may be noticed by standing near the conductor of a powerful electric machine, when shocks are felt at every discharge.

The effects of the return shock are sometimes quite severe. These effects are often experienced by sensitive people on the occurrence of a lightning discharge at a considerable distance.

In some instances the return stroke has been sufficiently intense to cause death. In general, however, the effects are much less severe than those of the direct lightning discharge.

Struts for Telegraphic Poles.—Inclined wooden or iron poles, applied to telegraph poles in order to support the thrust or pressure acting on them. (See *Pole, Telegraphic*.)

Sturgeon's or Barlow's Wheel.—A wheel capable of rotation on a horizontal axis, which, when placed between the poles of a magnet, rotates when a current is passed through it between the axis and the circumference.

Sub-Aqueous Cable.—(See *Cable, Sub-Aqueous*.)

Sub-Branch.—(See *Branch, Sub*.)

Sub-Main.—(See *Main, Sub*.)

Submarine Boat.—(See *Boat, Submarine, Electric*.)

Submarine Cable.—(See *Cable, Submarine*.)

Submarine Mine.—(See *Mine, Submarine*.)

Submarine Telegraphy.—(See *Telegraphy, Submarine.*)

Substance, Ferro-Magnetic — —A term proposed in place of paramagnetic, for substances that are magnetic after the manner of iron. (See *Paramagnetic.*)

Subterranean Mine. (See *Mine, Subterranean.*)

Subway, Electric — —An accessible underground way or passage provided for the reception of electric wires or cables.

Underground electric conductors, like all electric conductors, are liable to faults, crosses, etc. Unless they are readily accessible, very serious loss and damage may occur before the fault is located and corrected.

Sulphating.—A name applied to one of the sources of loss in the operation of a storage battery, by means of the formation of a coating of inert sulphate of lead on the battery plates.

The addition of a solution of sulphate of soda to the sulphuric acid liquid is claimed to have the effect of decreasing the extent of the sulphating.

Summer Lightning.—(See *Lightning, Summer.*)

Sun Spots.—(See *Spots, Sun.*)

Sunstroke, Electric, or Electric Prostration or Insolation — —Physiological effects, similar to those produced by exposure to the sun, experienced by those exposed for a long while to the intense light and heat of the voltaic arc.

Electric sunstroke is sometimes called electric insolation, or electric prostration.

The effects of electric sunstroke were first noticed by Desprez in his classic experiments on the fusion or volatilization of carbon.

On undue exposure to an intense electric light the eyes are irritated and the skin burned as by the sun. In some cases it is claimed that the effects of sunstroke, or excessive production of heat, as in true *insolation*, are produced. In the applications of electricity to electric furnaces, these same effects have been noticed in an intensified degree.

From some recent investigations it would appear that these effects are to be ascribed to the light rather than to the heat.

The symptoms are as follows: Pain in the throat, face and temples, followed by a coppery red color of the skin, irritation and watering of the eyes, when the symptoms disappear. The skin peels off in about five days.

Superficial Eddy Currents.—(See *Currents, Eddy, Superficial.*)

Super-Saturation of Solution.—(See *Solution, Super-Saturation of.*)

Supplement of Angle.—(See *Angle, Supplement of.*)

Supply, Unit of, Electrical — —A unit, provisionally adopted in England by the Board of Trade, equal to 1,000 ampères flowing for one hour under an electromotive force of one volt.

This would, of course, equal 1,000 watt-hours, and would be the same as 100 ampères flowing for ten hours under one volt.

One unit of electrical supply is equal to 1.34 actual horse-power expended for one hour, and will feed 13.4 Swan lamps of 21 candle-power for one hour. It is equal in illuminating power in Swan lamps to the light produced by 100 cubic feet of gas consumed in twenty 14-candle burners in one hour.

The unit of electrical supply is called a "Board of Trade unit," a B. O. T. unit, or simply a bot. It is equal to one kilo-watt hour.

Support, Tripod Roof — —A support for a housetop telegraphic line.

The tripod roof support, as its name indicates, consists of a three-legged support for any suitable insulator.

A common form is shown in Fig. 516.

Support, Underground Cable — —A support provided for holding a cable where it passes around the side of a man-hole, underground conduit, or other similar location.

Surface, Demarcation — —The surface at which a demarcation current is generated.

The surface which marks the point of injury in a muscle or nerve.

Demarcation currents in electro-therapeutics, are currents produced in injured nerves or muscles. They are probably due to the chemical changes that take place between the injured and the uninjured tissues. The demarcation surface is

the surface separating parts in a normal condition from those in an abnormal condition.

An injury to a muscle or nerve causes or produces at such surface a dying substance which is

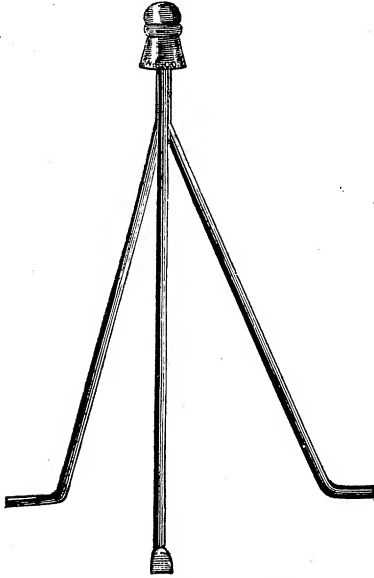

Fig. 516. Tripod Roof Support.

negative to the uninjured, normal or positive substance. Such a surface results in a demarcation current.

Surface Density.—(See *Density, Surface*.)

Surface, Equipotential, of a Conductor Through Which a Current is Flowing —

—A surface described within the mass of a conductor, conveying an electric current, at points perpendicular to the direction of the flow, all possessing the same potential.

Surface, Equipotential, or Level Surface of Escaping Fluid — —A surface described within the mass of a fluid in motion at all places perpendicular to the stream lines passing such surface.

Surface Integral of Magnetic Induction. —(See *Induction, Magnetic, Surface-Integral of*.)

Surfaces, Equipotential, Electrostatic — —Surfaces, all the points of which are at the same electric potential. (See *Potential, Electric*.)

Electric surfaces perpendicular to the lines of electric force over which a quantity of electricity, considered as being concentrated at a point, may be moved without doing work. (See *Field, Electrostatic*.)

Equipotential surfaces correspond with a water level, over which a body may be moved horizontally without doing any work against the force of gravity.

In the case of the charged insulated sphere, shown in Fig. 517, the equipotential surfaces, represented by the circles, are concentric.

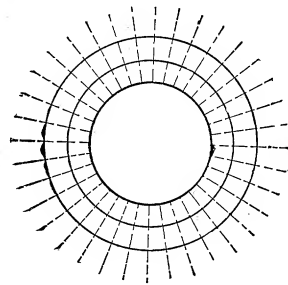

Fig. 517. Equipotential Surfaces.

Surfaces, Equipotential, Magnetic —

—Surfaces surrounding the poles of a magnet, or system of magnets, where the magnetic potential is the same. (See *Potential, Magnetic*.)

Magnetic equipotential surfaces extend in a direction perpendicular to the lines of magnetic force. (See *Field, Magnetic*.)

No work is required in order to move a unit pole over equipotential magnetic surfaces, because in so doing it cuts no lines of magnetic force. Work, however, is done when the motion is from one equal potential surface to another.

Equipotential surfaces, whether electric or magnetic, cannot intersect one another, since their potential is the same at all points.

Surfaces, Isothermal — —Surfaces connecting points in a body which have the same temperature.

Surging Discharge.—(See *Discharge, Surging*.)

Surgings, Electric — —Electric oscillations set up in a charged conductor that is undergoing rapid discharge.

These surgings produce waves in the surrounding ether that travel outwards with the velocity of

light. (See *Electricity, Hertz's Theory of Electro-Magnetic Radiations or Waves.*)

Susceptibility, Magnetic — —The ratio existing between the induced magnetization and the magnetic force producing such magnetism, or the intensity of magnetism divided by the magnetic force.

Susceptibility relates to the *poles* produced in a body by a magnetizing force, whereas permeability refers its power to *conduct* lines of force. When the inducing field has unit strength of magnetization, the magnetic susceptibility will measure directly the strength of the magnetization.

When a bar of iron is placed in a magnetic field, it is threaded by the lines of magnetic force, and thus becomes magnetized by *induction*. This induction will necessarily depend both on the number of lines of force in the magnetizing field and on the *magnetic permeability* of the magnetized body; or, in other words, the *induction* is equal to the product of the intensity of the magnetizing field and the magnetic permeability of the body in which the induction occurs.

The magnetic susceptibility is sometimes called the Co-efficient of Magnetization; calling K , the susceptibility, H , the magnetizing force, and I , the intensity of the resulting magnetization; then

$$K = \frac{I}{H}.$$

The magnetic permeability is sometimes called the Co-efficient of Magnetic Induction, calling μ , the permeability, B , the magnetic induction and H , the magnetic force producing the induction; then

$$\mu = \frac{B}{H}.$$

Suspending Wire of Aërial Cable.—(See *Wire, Suspending, of Aërial Cable.*)

Suspension, Bifilar — —The suspension of a needle by two parallel wires or fibres, as distinguished from a suspension by a single wire or fibre.

A bifilar suspension is shown in Fig. 518. The two threads, a, b and a', b' , are connected to the needle $M N$, so as to permit it to hang in a true horizontal position. Any

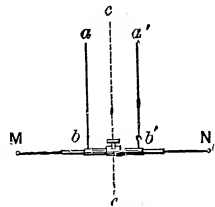

Fig. 518. Bifilar Suspension.

twisting, around the imaginary axis $c c'$, causes the lines of suspension, $a b$ and $a' b'$, to tend to cross one another and so shorten the axis $c c'$.

Harris, who was the first to employ the bifilar suspension, showed that the reactive force imparted to the suspension threads by turning the needle, was:

- (1.) Directly proportional to the distance between the threads.
- (2.) Inversely as their lengths.
- (3.) Directly proportional to the weight of the suspended body.
- (4.) Proportional to the angle of twist or torsion of the threads on each other.

Any deflection of the needle shortens the vertical distance between the points of support and the needle, and so tends to lift the needle. The motions are therefore balanced against the force of gravity instead of against the torsion of the fibre.

Suspension, Combined Fibre and Spring — —The suspension of a needle by the combined use of a spiral spring and a single fibre.

In this form of suspension the spring is introduced between the fibre and the needle. It is valuable for marine galvanometers and other apparatus exposed to tilting or rolling motions, because it permits the instrument to be tilted through several degrees without causing any considerable variation in the deflections produced by the current or the charge.

Suspension, Fibre — —Suspension of a needle by means of a fibre of unspun silk or other material.

A fibre suspension generally means a single fibre or thread. It may, however, be applied to a bifilar suspension. (See *Suspension, Bifilar.*)

A fibre suspension is to be preferred to a *pivot* suspension, since it eliminates all friction. It has, however, the disadvantage of necessitating leveling screws.

Suspension, Knife-Edge — —The suspension of a needle on knife edges that are supported on steel or agate planes.

A suspension of this kind is used in the dipping needle, since it permits of freedom of motion in a single vertical plane only.

Suspension, Pivot — —Suspension of a needle by means of a jeweled cup and a metallic pivot.

The jeweled cup is placed above the centre of gravity of the needle, and is supported on a steel point. As a rule, compass needles have this variety of support.

Swage.—A particular form of anvil on which highly heated metallic plates are shaped by hammering them into forms the same as that of the anvil on which they are placed.

Swage.—To fashion heated metallic plates by hammering them into the form of an anvil on which they are supported.

Swaging.—Fashioning highly heated metallic plates into any desired form by hammering while on suitable dies.

Swaging, Electric — —The forming or shaping of metallic plates by hammering them against suitable anvils or dies while softened by electrical heating.

The electro-swaging apparatus consists of a welding transformer provided with a movable clamp. The pressure required for the swaging is attained by the use of steam admitted into a cylinder by a lever which operates a four-way valve.

The rod, bar, or plate of metal to be shaped or swaged, is first heated by the passage of a powerful heating current, obtained preferably from a welding transformer, one of the clamps of which is movable. When the metal is suitably softened by the passage of the current, it is then subjected to swaging.

Swelling Current.—(See *Currents, Swelling*.)

Swelling Faradic Current.—(See *Currents, Swelling Faradic*.)

Swinging Annunciator.—(See *Annunciator, Pendulum or Swinging*.)

Swinging Cross.—(See *Cross, Swinging or Intermittent*.)

Switch, Automatic, for Incandescent Electric Lamps — —A device by which incandescent electric lamps can be lighted or extinguished at a distance by means of push buttons.

The automatic switch for incandescent lamps corresponds in electric lighting to the automatic gaslighting device in systems of electric gaslighting. It consists essentially of two electro-magnets, one for turning the switch which lights

the lamp by cutting them into the circuit of the lighting mains or conductors, and the other for extinguishing them, by cutting them out. These electro-magnets are operated by two push buttons, a black one to extinguish the lamp and a white button to light it.

The details of the automatic switch are shown in Fig. 520. The mains M^1 and M^2 , are connected to one set of contacts, and the branches containing

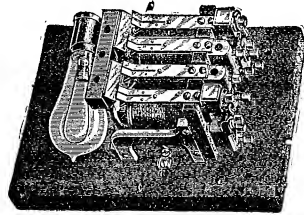

Fig. 519. Automatic Switch.

the lamps to be lighted, to the contacts between them. The push buttons, P^1 and P^2 , are connected by their wires to the main M^1 and the branch R^1 .

These buttons are made respectively positive and negative, and are marked + and —. The third wire of the push button is connected as shown to the lamp L , and the switch magnet, $S M$.

When the contact is closed at P^1 , the armature of $S M$, closes the contact through C . When the button is released, connection is estab-

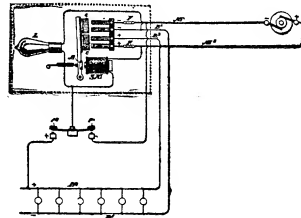

Fig. 520. Automatic Switch.

lished between the magnet and the lamp L , in series. This is for the purpose of cutting down the circuit to the $\frac{1}{10}$ of an ampère, and thus permitting a thin wire to serve between the button and the switch magnet.

When the button, P^2 , is closed the lamps are turned out.

Switch Board.—(See *Board, Switch*.)

Switch Board, Multiple — —(See *Board, Multiple Switch*.)

Switch Board, Telegraphic — —(See *Board, Switch, Telegraphic.*)

Switch Board, Trunking — —(See *Board, Switch, Trunking.*)

Switch, Break-Down — —A special switch, employed in small three-wire systems, for connecting the positive and negative bus-wires in such a manner as to practically convert it into a two-wire system and permit the system to be supplied with current from a single dynamo. (See *Wires, Bus.*)

Switch, Changing — —A switch designed to throw a circuit from one electric source to another.

A changing switch, for example, is of use in disconnecting a circuit from one dynamo and connecting it to another; or, in other words, to suddenly transfer the load from one dynamo to another.

Switch, Changing-Over — —A term sometimes applied to a changing switch. (See *Switch, Changing.*)

Switch, Distributing — —A multiple switch board. (See *Board, Multiple Switch.*)

Switch, Distributing, for Electric Lights — —A switch employed in a system of arc lighting by series-distribution, by means of which any particular dynamo-electric machine or a number of

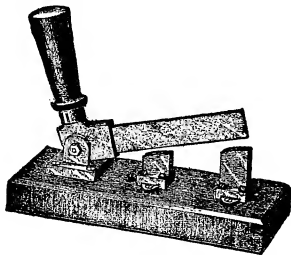

Fig. 521. Double-Break Knife Switch.

separate dynamo-electric machines can be connected with the same circuit without interfering with the lights. (See *Board, Multiple Switch.*)

Switch, Double-Break — —A term sometimes used for double-pole switch. (See *Switch, Double-Pole.*)

Switch, Double-Break Knife — —A knife switch provided with double-break contacts.

A double-break knife switch is shown in Fig. 521.

Switch, Double-Pole — —A switch that makes or breaks contact with both poles of the circuit in which it is placed.

A switch consisting of a combination of two separate switches, one connected to the positive lead and the other to the negative lead.

Double-pole switches are used in most systems of incandescent lighting in order to insure the thorough separation of the circuit from the main conductor or leads when cut out and to diminish the spark.

Switch, Feeder — —The switch employed for connecting or disconnecting each conductor of a feeder from the bus-bars in a central station.

Switch, Four-Point — —A switch by which a circuit can be completed through four central points.

Switch, Knife — —A switch which is opened or closed by the motion of a knife

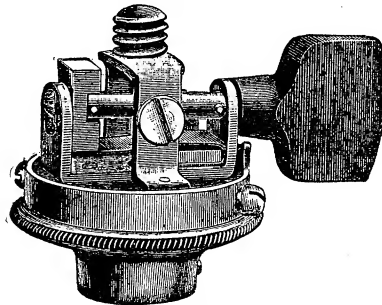

Fig. 522. Lamp-Socket Switch.

contact which moves between parallel contact plates.

A knife-edge switch. (See *Switch, Knife-Edge.*)

Switch, Knife-Break — —A knife switch. (See *Switch, Knife.*)

Switch, Knife-Edge — —A term sometimes used in place of knife switch. (See *Switch, Knife.*)

Switch, Lamp-Socket — —A switch placed in the socket of an incandescent lamp and provided for throwing the lamp in and out of the circuit.

A form of lamp socket switch is shown in Fig. 522. Its operation will be understood from an inspection of the drawing.

Switch Pin.—(See *Pin, Switch*.)

Switch, Plug — —A switch in which a metal plug is withdrawn to throw into a circuit a coil or other device, the ends of which are connected to metallic blocks that are sufficiently near together to be joined and short-circuited by the insertion of the plug.

Switch, Pole-Changing — —A switch employed for changing the direction of the current in any circuit.

A form of pole-changing switch is shown in Fig. 523.

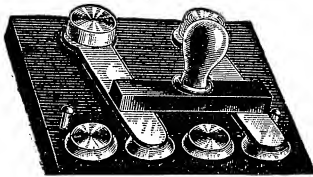

Fig. 523. Pole-Changing Switch.

If the two outer contacts are connected to the same pole as the source, as, for example, the positive, and the two intermediate contacts are connected to the other pole, or to the negative, then in the position shown in the cut, the current will flow through any receptive device connected with the switch, in one direction, but if the switch is moved to the left, it will flow in the opposite direction.

Switch, Removable Key — —A plug switch. (See *Switch, Plug*.)

Switch, Reversing — —A switch for reversing the direction of the battery current through a galvanometer.

A simple reversing switch consists of four insulated brass segments mounted on a plate of ebonite and furnished with openings between them for plug connections.

The battery terminals are connected to two diagonally opposite segments, as B, and D, Fig. 524, and the leading wires of the galvanometer,

or other instrument, to the other segments, as C and A. If, now, the plugs are placed between B and C, and A and D, the battery current flows in one direction. If, however, the plugs are

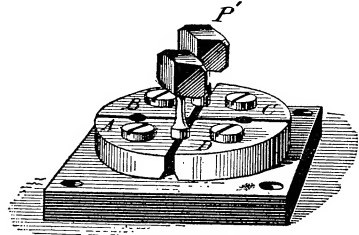

Fig. 524. Reversing Switch.

placed between A and B, and C and D, the battery current will flow in the opposite direction.

The battery current is cut off if one plug is removed. In practice, however, it is preferable to remove both plugs, so as to avoid any current from want of sufficient insulation.

Switch, Snap — —A switch in which the transfer of the contact points from one position to another is accomplished by means of a quick motion obtained by the operation of a spring.

The object of the snap switch is to prevent the switch resting in any half way position, and thus preventing the establishing of an arc.

Switch, Telephone, Automatic — —A device for automatically transferring the connection of the main line from the call bell to the telephone circuit.

In most telephone circuits, as now arranged, the automatic switch, besides transferring the main line from the call bell to the telephone circuit,

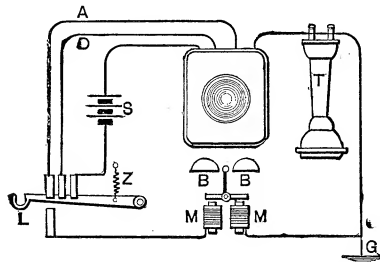

Fig. 525. Automatic Telephone Switch.

closes the local battery circuit of the transmitter on the removal of the telephone from its supporting hook.

The means whereby this is accomplished are shown in Fig. 525. On the removal of the telephone from the hook L, the lever is pulled upwards by the spring Z, thus closing the contacts 1, 2 and 3, by which the local battery S, is closed through the circuit of the transmitter, the telephone disconnected from the circuit of the call bell M, B, and connected with the circuit of the transmitter. On replacing the telephone on the hook L, its weight depresses the lever, breaking connection with 1, 2 and 3, and establishing connection with the call circuit.

Switch, Three-Point — —A switch by means of which a circuit can be completed through three different contact points.

Switch, Time — —An automatic switch in which a predetermined time is required either to insert a resistance in or remove it from a circuit.

Switch, Two-Point — —A switch by

means of which a circuit can be completed through two different contact points.

Switch, Two-Way — —A switch provided with two contacts connected with two separate and distinct circuits.

Switch, Yale-Lock, for Burglar Alarm — —(See *Alarm, Yale-Lock Switch Burglar.*)

Switched-In.—Placed in a circuit by means of a switch. (See *Closed-Circuited.*)

Switched-Out.—Cut out of a circuit by means of a switch. (See *Open-Circuited.*)

Symbols and Diagrams, Standard Electric — —Standard symbols and diagrams used in electro-technics.

The standard electric diagrams and symbols shown on pages 501, and 502, were arranged by Prof. F. B. Crocker, and are reproduced from the *Electrical Engineer*.

SYMBOLS COMMONLY USED IN ELECTRICAL WORK.

MECHANICAL.		ELECTRICAL.		MAGNETIC.
L or l. Length	D. Diameter	E. or E.M.F. Electromotive force	v. Volt	N. North pole
M or m. Mass	r. Radius	P.D. Potential difference	amp. Ampere	S. South pole
T or t. Time	H.P. Horse power	C. Current	ω . Ohm	m. Strength of pole
v. Velocity	L.H.P. Indicated "	R. Resistance	Ω . Megohm.	H. Magnetizing force (C.G.S.)
F or f. Force	B.H.P. Brake "	ρ . Specific resistance	B.A.U. Brit. Ass'n Unit	B. Magnetic induction (C.G.S. lines)
g. Acceleration due to gravity.	r.p.m. Revolutions per min.	Q. Quantity	mfd. Microfarad	I. Intensity of magnetization
W or w. Work.	C.G.S. Centimetre gramme second (System)	K. Electrostatic capacity.	h. or hy. Henry	μ . Magnetic permeability
P. Power.	A.W.G. American Wire Gauge	L. Inductance (Coeff. of)	z. Electrochemical equivalent	κ . Magnetic susceptibility
ft. lb. Foot pound.	B.W.G. Birmingham Wire Gauge	A.M. Amperemeter.	J. Joule	H. Horizontal intensity of Earth's magnetism
		V.M. Voltmeter	K.W. Kilowatt	
		F.M. Field Magnet	Complete period (Alt. cur.)	
		+ Positive pole or terminal	\mathcal{D} . Dynamo	
		- Negative " " "	\mathcal{B} . Battery	

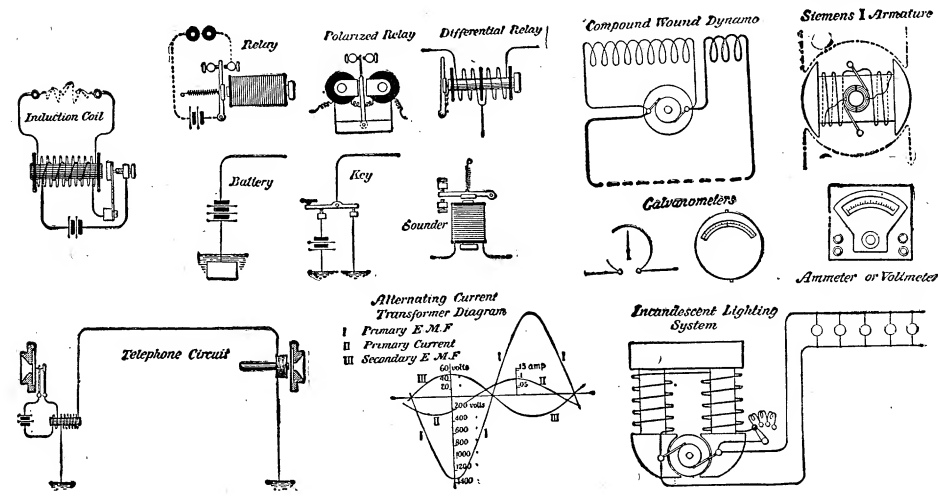

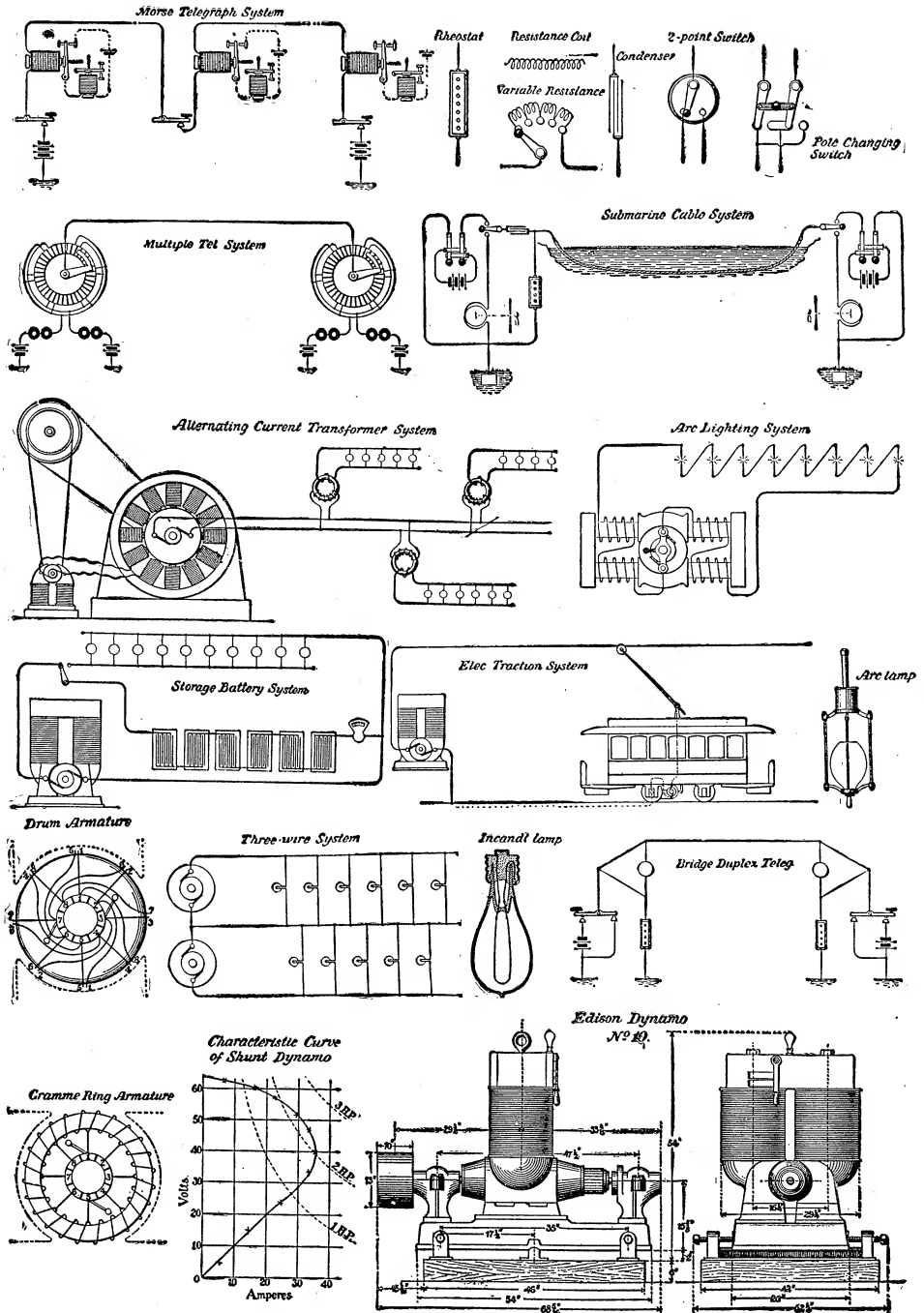

Fig. 526. Crocker's Chart of Standard Electric Symbols and Diagrams.

Symmetrical Induction of Armature.—(See *Induction, Symmetrical, of Armature.*)

Symmetrical Magnetic Field.—(See *Field, Magnetic, Symmetrical.*)

Sympathetic Electrical Vibrations.—(See *Vibrations, Sympathetic Electrical.*)

Sympathetic Vibrations.—(See *Vibrations, Sympathetic.*)

Synchronism.—The simultaneous occurrence of any two events.

A rotating cylinder, or the movement of an index or trailing arm, is brought into synchronism with another rotating cylinder or another index or trailing arm, not only when the two are moving with exactly the same speed, but when in addition they are *simultaneously moving over similar portions of their respective paths.*

In the Breguet *Step-by-Step* or *Dial Telegraph* (See *Telegraphy, Step-by-Step*), the movements of the needle on the indicator are synchronized with the movements of the needle on the *manipulator.*

In systems of *Fac-Simile Telegraphy* the movements of the transmitting apparatus are synchronized with those of the receiving apparatus.

In Delany's *Synchronous Multiplex Telegraph System*, the trailing arm that moves over a circular table of contacts at the transmitting end, is accurately synchronized with a similar trailing arm moving over a similar table at the receiving end.

Delany, who was the first to obtain rigorous synchronism at the two ends of a telegraphic line hundreds of miles in length, accomplishes this by the use of La Cour's phonic wheel, through the agency of correcting electric impulses, automatically sent in either direction over the main line, when one trailing arm gets a short distance in advance or back of the other.

With alternating current dynamos, where one dynamo is feeding incandescent lamps connected to the leads in multiple, and it is desired to couple another alternating current dynamo in parallel with the first, it is necessary to obtain a complete synchronism of the two dynamos before coupling them, since otherwise the lamps will show variations in their light, and the machine may suffer.

Synchronizable.—Capable of being synchronized. (See *Synchronism.*)

Synchronize.—To cause to occur or act simultaneously. (See *Synchronism.*)

Synchronized.—Caused to occur or act simultaneously. (See *Synchronism.*)

Synchronizing Dynamo-Electric Machine.—(See *Machine, Dynamo-Electric, Synchronizing.*)

Synchronous Multiplex Telegraphy.—(See *Telegraphy, Synchronous Multiplex, Delany's System.*)

System, Astatic — — An astatic combination of magnets.

An astatic needle consists of an astatic system of two magnetic needles. The needles are rigidly fixed together with their opposite poles facing each other. The two needles form an astatic pair or couple. (See *Needle, Astatic.*)

System, Block, for Railways — — (See *Railroads, Block System for.*)

System, Centimetre - Gramme - Second — — (See *Units, Centimetre - Gramme - Second.*)

System, Continuous Underground, of Motive Power for Electric Railroads — — (See *Railroads, Electric, Continuous Underground System of Motive Power for.*)

System, Dependent, of Motive Power for Electric Railroads — — (See *Railroads, Electric, Dependent System of Motive Power for.*)

System, Independent, of Motive Power for Railroads — — (See *Railroads, Electric, Independent System of Motive Power for.*)

System, Multiphase — — A term frequently applied to a system of rotating electric currents. (See *Current, Rotating.*)

System of Distribution of Electricity by Commutating Transformers.—(See *Electricity, Distribution of, by Commutating Transformers.*)

System of Distribution of Electricity by Condensers.—(See *Electricity, Distribution of, by Alternating Currents by Means of Condensers. Electricity, Distribution of, by Continuous Current by Means of Condensers.*)

System of Distribution of Electricity by Means of Alternating Currents.—(See *Elec-*

tricity, Distribution of, by Alternating Currents.)

System of Distribution of Electricity by Motor Generators.—(See *Electricity, Distribution of, by Motor Generators.*)

System, Three-Wire — — A system of electric distribution for lamps or other translating devices connected in multiple, in which three wires are used instead of the two usually employed.

In the three-wire system two dynamos are generally employed, which are connected with one another in series.

The three conductors are connected as shown in Fig. 527, the central conductor to the junction of the two dynamos and the two others to their free terminals, and the difference of potential between the central and the two outer conductors is maintained the same. The lamps, or other electro-receptive devices, are placed in multiple-arc between either branch, and so distributed that the current in each branch is the same. When such balance is established no current flows through the central or *neutral* conductor. But when that balance is disturbed, the surplus current in one branch is taken up by the central conductor.

The three-wire system effects considerable

economy in the weight of wire required. Since in the multiple-series-connection of electro-receptive devices whatever difference of potential is impressed on the mains is fed to each device, no higher difference of potential can be employed on the mains than that which the devices are capable of taking. In the case of an incandescent lamp, if such difference be exceeded, too strong a current is passed through the lamps with a consequent decrease in their life.

In the three-wire system of distribution a higher difference of potential can be maintained on the mains than is required for any lamp placed in

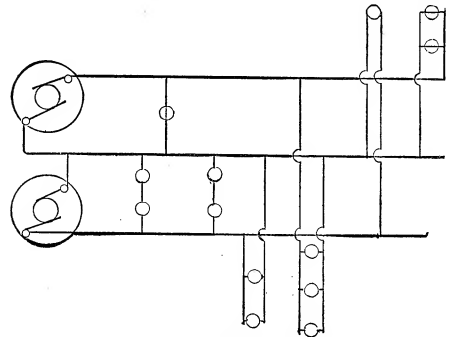

Fig. 527. Three-Wire System.

connection therewith, and in this manner a considerable saving is effected in the cost of the leads.

T

T.—A symbol used for time.

T-shaped Spark.—(See *Spark, T-Shaped.*)

Table, Quadruplex, A-Side of — — That side of a quadruplex system which is worked by means of reverse currents. (See *Telegraphy, Quadruplex.*)

Table, Quadruplex, B-Side of — — That side of a quadruplex system which is worked by means of strengthened currents. (See *Telegraphy, Quadruplex.*)

Tables of Conducting Powers.—(See *Powers, Conducting, for Electricity. Resistance, Electric.*)

Tachograph.—An apparatus for recording the number of revolutions per minute of a shaft or machine.

Tachometer.—An apparatus for indicating at any moment on a revolving dial the exact number of revolutions per minute of a shaft or machine.

A tachometer is sometimes called a speed indicator.

Tachyphore.—A term proposed by Wurtz for a system of electric transportation, in which a carriage, formed of magnetic material, is propelled by the sucking action of solenoids placed along the track and energized in succession during the passage of the car.

This is generally called the portelectric system. (See *Portelectric.*)

Tail Light.—(See *Light, Tail.*)

Tailings.—False markings received in systems of automatic telegraphy, due to retardation. (See *Retardation*.)

Tailings.—A term applied to the current that runs out of a line at the receiving end.

The current that continues to run out at the receiving end of the circuit after the sending current is broken.

The tailings in a telegraphic line are due to the effects of self-induction and static capacity following the breaking of the circuit which produce a current in the same direction as that sent into the line. Consequently, on the breaking of the circuit, the current continues to flow out of the line at the distant or receiving end. This prolongation of the original current is known technically as the tailing or the tailing current.

Talk, Cross — —In telephony an indistinctness in the speech transmitted over any circuit, due to this circuit receiving, either by accidental contacts or by induction, the speech transmitted over neighboring circuits.

Tangent.—One of the trigonometrical functions. (See *Function, Trigonometrical*.)

Tangent and Sine Galvanometer, Combined — —(See *Galvanometer, Combined Tangent and Sine*.)

Tangent Galvanometer.—(See *Galvanometer, Tangent*.)

Tangent Scale.—(See *Scale, Tangent*.)

Tangentially Laminated Armature Core.—(See *Core, Armature, Tangentially Laminated*.)

Tank, Cable — —A water-tight tank in which a section of a cable is placed for purposes of testing.

The cable is tested either when merely covered by water, or when subjected to a pressure approximately equal to or in excess of that to which it will be subjected when laid in the water.

Reid has constructed cable tanks for testing under pressures as great as 4,500 pounds per square inch. The pressure is obtained by means of force pumps.

When a cable section is subjected to these pressures any flaws or defects would be at once detected by the entrance of the water.

Tanning, Electric — —An application of electric currents to tanning leather.

The dressed hides are steeped in a solution of tannin through which an electric current is passed.

It is claimed, that by this process, the hides are thoroughly tanned in from one to four days, in place of from four to twelve months, as required by the ordinary process.

The tanning solution is placed in a vat furnished with suitable electrodes and filled with the tanning liquid, and the articles to be tanned are placed between the electrodes and a motion of revolution given to the vat. By these means the time required for the completion of the process is considerably shorter than that required by the ordinary process.

Tap.—A conductor attached to a larger conductor in a shunted circuit.

Tap, Ampère — —A tap provided for carrying off a current of one ampère.

Tap Wires.—(See *Wires, Tap*.)

Tape, Insulating — —A ribbon of flexible material impregnated with kerite, okonite, rubber or other suitable insulating material, employed for insulating wires or electric conductors at joints, or other exposed places.

Sometimes the tape is formed entirely of some or another the above named insulating materials.

Taped Wire.—(See *Wire, Taped*.)

Tapper, Double-Key — —(See *Key, Double Tapper*.)

Target, Electric — —A target in which the point struck by the ball is automatically registered by means of electric devices.

A variety of targets have been devised. Generally, however, the target is divided into a number of separate sections provided with circuits of wires, on the making or breaking of any of which, by the impact of the ball, the section struck is automatically indicated on an electric *annunciator*. (See *Annunciator, Electro-Magnetic*.)

Taste, Galvanic — —A sensation of taste produced when a voltaic current is passed through the tongue or in the neighborhood of the gustatory nerves, or nerves of taste.

Teaser.—An electric current teaser. (See *Teaser, Electric Current.*)

Teaser, Electric Current — —A coil of fine wire placed on the field magnets of a dynamo-electric machine, underneath the series coil wound thereon, and connected as a shunt across the main circuit.

The name teaser was applied by Brush to the coil of fine wire used as above described to maintain constant electromotive force under variations of load.

Technics, Electro — —The science which treats of the physical applications of electricity and the general principles applying thereto.

Tee, Lead — —A tee-shaped lead tube provided for the purpose of taking a branch joint from a main cable to a service line.

Tee, Split-Lead — —A tee-shaped lead tube that is split for readily covering a joint at a loop in a cable.

Tel-Autogram.—The recorded message obtained by means of a tel-autograph. (See *Tel-Autograph.*)

Tel-Autograph.—A telegraphic system for the fac-simile reproduction of handwriting.

Teleautograph.—An orthography sometimes employed for tel-autograph. (See *Tel-Autograph.*)

Tele-Barometer, Electric — —An electric recording barometer for indicating and recording barometric or other pressures at a distance.

Telegrapher's Cramp.—(See *Cramp, Telegrapher's.*)

Telegraphic.—Pertaining to telegraphy.

Telegraphic Alarm.—(See *Alarm, Telegraphic.*)

Telegraphic Alphabet.—(See *Alphabet, Telegraphic.*)

Telegraphic Alphabet, Continental Code — —(See *Alphabet, Telegraphic: International Code.*)

Telegraphic Alphabet, Morse's — —(See *Alphabet, Telegraphic: Morse's.*)

Telegraphic Arm.—(See *Arm, Telegraphic.*)

Telegraphic Bracket.—(See *Bracket, Telegraphic.*)

Telegraphic Cable.—(See *Cable, Telegraphic.*)

Telegraphic Code.—(See *Code, Telegraphic.*)

Telegraphic Earth-Circuit.—(See *Circuit, Earth, Telegraphic.*)

Telegraphic Embosser.—(See *Embosser, Telegraphic.*)

Telegraphic Fixtures.—(See *Fixtures, Telegraphic.*)

Telegraphic Fixtures, House-Top — —(See *Fixtures, Telegraphic House-Top.*)

Telegraphic Ground Circuit.—(See *Circuit, Ground, Telegraphic.*)

Telegraphic Joints.—(See *Joint, Telegraphic or Telephonic.*)

Telegraphic Key.—(See *Key, Telegraphic.*)

Telegraphic Line Circuit.—(See *Circuit, Line, Telegraphic.*)

Telegraphic Needle.—(See *Needle, Telegraphic.*)

Telegraphic Paper Winder.—(See *Winders, Telegraphic Paper.*)

Telegraphic Pocket Relay.—(See *Relay, Pocket Telegraphic.*)

Telegraphic Register.—(See *Register, Telegraphic.*)

Telegraphic Switch Board.—(See *Board, Switch, Telegraphic.*)

Telegraphic Translator.—(See *Translator, Telegraphic.*)

Telegraphically. — In a telegraphic manner.

Telegraphing.—Sending a communication by means of telegraphy.

Telegraphy, Acoustic — —A non-recording system of telegraphic communication, in which the dots and dashes of the Morse system, or the deflections of the needle in the needle system, are replaced by sounds

that follow one another at intervals, that represent the dots and dashes, or the deflections of the needle, and thereby the letters of the alphabet.

Morse invented a *souder*, for this purpose, which is used very generally. (See *Souder, Morse Telegraphic.*)

Steinheil and Bright each invented acoustic systems of telegraphy in which electro-magnetic bells are used.

For details of the apparatus and system see *Telegraphy, Morse System of.*

Telegraphy, American System of — —

A term sometimes applied to the Morse system of telegraphy. (See *Telegraphy, Morse System of.*)

Telegraphy and Telephony, Simultaneous, Over a Single Wire — — Any system for simultaneous transmission of telegraphic and telephonic messages over a single wire.

These systems are based, in general, on the fact that a gradual make-and-break in a telephone circuit fails to appreciably affect a telephone diaphragm. By the use of graduators the makes and breaks required for the transmission of the telegraphic dispatch are effected so gradually that they fail to appreciably influence the telephone diaphragm, and thus permit simultaneous telegraphic and telephonic transmission over a single wire. (See *Graduators.*)

Telegraphy, Autographic — — A name sometimes applied to fac-simile telegraphy. (See *Telegraphy, Fac-Simile.*)

Telegraphy, Automatic — — A system by means of which a telegraphic message is automatically transmitted by the motion of a previously perforated fillet of paper containing perforations of the shape and order required to form the message to be transmitted.

The paper passes between two terminals of the main line, the circuit of which is completed when the terminals come into contact at the perforated parts, and is broken when separated by the unperforated parts of the paper.

In the automatic telegraph some form of registering apparatus is employed.

In the Wheatstone system, the perforations mechanically control the movements of the levers which make contacts between the line and the battery.

The advantage of automatic telegraphy arises from the fact that the rate of transmission or reception of signals does not depend on the expertness of the operators, and the messages may be perforated on the slips preparatory to transmission.

Type-printing telegraphs are often used for registering apparatus, in which case the impulses required for the transmission of the different letters are automatically sent into the line by the depression of corresponding keys on a suitably arranged key-board.

Telegraphy, Chemical — — A system by means of which the closings of the main-line-circuit, corresponding to the dots and dashes of the Morse alphabet, are recorded on a fillet of paper by the electrolytic action of the current on a chemical substance with which the paper fillet is impregnated. (See *Recorder, Chemical, Bain's.*)

Telegraphy, Contraplex — — Duplex telegraphy in which transmissions are simultaneously made from opposite ends of the line.

When the transmissions are simultaneously made from the *same* end of the line, the system is called diplex telegraphy. (See *Telegraphy, Diplex.*)

Telegraphy, Dial — — A system of telegraphy in which the messages are received by the motions of a needle over a dial plate. (See *Telegraphy, Step-by-Step.*)

Telegraphy, Diplex — — A method of simultaneously sending two messages in the same direction over a single wire.

Diplex telegraphy is to be distinguished from duplex telegraphy, where two messages are simultaneously transmitted over a single wire in *opposite* directions.

Telegraphy, Double-Needle — — A system of needle telegraphy in which two separate and independently operated needles are employed.

This system differs from the single-needle system only in the fact that two needles, entirely independent of each other, are mounted side by side, on the same dial, so as to permit their simultaneous operation by the right and left hand of the

operator. Each needle has therefore a separate wire.

The increase in speed of signaling thus obtained is not, however, sufficiently great to balance the increased expense of construction. Single-needle instruments, therefore, are preferred to those with two needles.

Telegraphy, Duplex, Bridge Method of

—A system whereby two telegraphic messages can be simultaneously transmitted over a single wire in opposite directions.

Various duplex telegraphs have been devised.

The *Bridge Duplex* is shown in Fig. 528. The receiving relay is placed in the cross wire of a *Wheatstone bridge*. (See *Bridge, Electric*.)

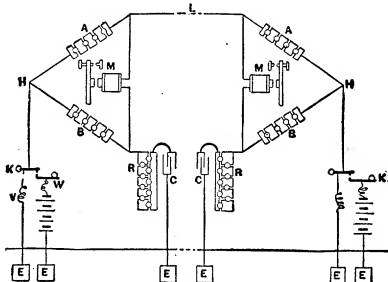

Fig. 528. Duplex Telegraphy, Bridge, Method.

When the ends of this cross wire are at the same potential, which will occur when the resistances in the four arms are proportionately equal, no current passes.

The battery is connected through the transmitter K, which is arranged so that the battery contact is made before the connection of the line to earth is broken, to H, where the circuits branch to form the arms of the bridge. Adjustable resistances A, B, are placed in the two arms of the bridge.

The line wire L, connected as shown, forms the third arm, and a *rheostat* or other adjustable resistance R, connected to a condenser C, as shown, forms the fourth arm. (See *Rheostat*.) The relay M, is placed in the cross wire of the bridge thus formed. Small resistances V, and W, are placed in the circuit of the battery to prevent injurious short circuiting.

A similar disposition of apparatus is provided at the other end of the line. If, now, the four resistances at one end are suitably adjusted, the relay will not respond to the outgoing current; but, since an earth circuit is employed, it will

respond to the incoming current. The relay at either end, therefore, will only respond to signals from the other end. The operator may thus signal the distant station while, at the same time, his relay, not being affected by his sending, is in readiness to receive signals from the other end.

Telegraphy, Duplex, Differential Method of

—A system of duplex telegraphy in which the coils of the receiving and transmitting instruments are differentially wound.

A differential system of duplex telegraphy is shown in Fig. 529. The coils of the receiving and transmitting galvanometers at A and B, are differentially wound. One of the coils of A, is connected to that of B, through the line, as shown; and the other, in each of the rheostats at R, and R'. As these coils are differentially wound, when equal currents flow in opposite directions through either of the instruments at A B, no deflection of the galvanometer occurs.

The battery at A, has its copper terminal, and that at B, its zinc terminal, connected to earth. When the keys at A and B, are depressed simultaneously, the currents sent into the line flow in the same direction and strengthen each other.

Suppose now that only the key at A, be depressed. The current divides equally between rheostat and line, the resistance $e a b b' a' e'$, r' , being made equal to the resistance $e c d R$.

This current passes through both coils of the instrument at A, and produces no deflection of the needle; but since it only passes through one coil at B, it deflects the galvanometer needle, and produces a signal.

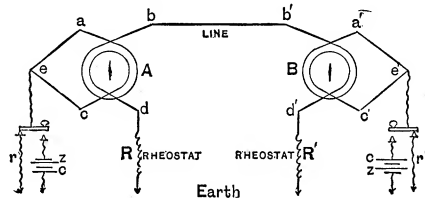

Fig. 529. Duplex Telegraphy, Differential Method.

If the keys at A, and B, are simultaneously closed, the effect on the line is to add the current of the two batteries, but each rheostat circuit is traversed by its own battery current only.

The line-connected coils of the galvanometer have, therefore, the stronger currents flowing through them, and the needles of both are moved, just as if, with a single battery discharging into the line, its resistance had been decreased. Each

sender's instrument is unaffected by the currents he sends into the line, and is, therefore, ready to be operated by the currents sent into the line by the sender at the other end of the line.

The two currents in duplex telegraphy, therefore, do not pass each other on the line; on the contrary, they are sent into the line in the same direction.

Since, when either key is moving there is a small interval of time when the circuit is broken for incoming currents, the keys are generally made so as to close the second contact before breaking the first.

In order to avoid disturbing the balance on the introduction of the resistance of the batteries at A or B, on closing the circuits, an equal resistance is added at r and r' , between the back stop and the earth.

Since the proper operation of duplex telegraphy requires a balance in the resistance of the circuits of the differentially wound coils, a rheostat at R, and R', is necessary.

Besides balancing the line for resistance, it is necessary to balance it for capacity. A condenser is, therefore, necessary when the circuit exceeds in length about 100 miles, or has much cable or underground wire.

Telegraphy, Fac-Simile — — A system whereby a fac-simile or copy of a chart, diagram, picture or signature is telegraphically transmitted from one station to another.

Fac-simile telegraphy is sometimes called autographic telegraphy, or pantelegraphy.

Bakewell's fac-simile telegraph, which was one of the first devised, consists of two similar metal cylinders c , c' , arranged at the two ends of a telegraph line L, at M and M', as shown in Fig. 530. These cylinders are synchronously rotated

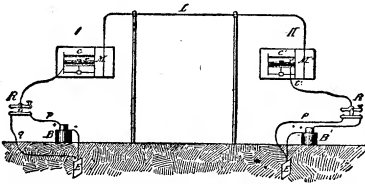

Fig. 530. Bakewell's Fac-Simile Telegraphy.

and provided with metallic arms or tracers r , r' , placed on a horizontal screw in the line circuit and moved laterally over the surface of the cylinder on its rotation.

At the transmitting station the chart, writing,

or other design is traced with varnish, or other non-conducting liquid, on the surface of the metallic cylinder, as at M, and a sheet of chemically prepared paper, similar to that employed in the Bain chemical system is placed on the surface of the receiving cylinder, at M'. (See *Recorder, Chemical, Bain's.*)

The two cylinders being synchronously rotated, the metallic tracer breaks the circuit in which it is placed when it moves over the non-conducting lines on the cylinder, and thus causes corresponding breaks in the otherwise continuous blue spiral line traced on the paper-covered surface of M'.

The telegraph keys at R, R', are used for the purposes of ordinary telegraphic communication before or after the record is transmitted.

Caselli's Pan-Telegraph is an improvement on Bakewell's Copying Telegraph. Better methods are employed for maintaining the synchronism between the transmitting and receiving instruments, for which purpose a pendulum, vibrating between two electro-magnets, is employed.

Telegraphy, Fire Alarm — — A system of telegraphy by means of which alarms can be sent to a central station, or to the fire engine houses in the district, from call boxes placed on the line.

The alarms are generally sounded by an apparatus similar to a district call, so that the pulling back of a lever rotates a wheel, by means of which successive makes and breaks are produced, the number and sequence of which enable the receiving stations to locate the particular box from which the signal is sent.

In the case of some buildings, the alarms are automatic, and either call for help from the central office, or for the watchman in the building, or else turn on a series of water faucets or jets, in order to extinguish the fire. In these cases *thermostats* are used. (See *Thermostat.*)

Telegraphy, Gray's Harmonic Multiple — — A system for the simultaneous transmission of a number of separate and distinct musical notes over a single wire, which separate tones are utilized for the simultaneous transmission of an equal number of telegraphic messages.

The separate tones are thrown into the lines by means of *tuning forks* automatically vibrated by electro-magnets. These forks interrupt the

circuit of batteries connected with the main line at the sending end of the line.

The composite tone thus formed, is separated into its component tones by receiving electromagnets called *harmonic receivers*, the armature of each of which consists of a steel ribbon or plate tuned to one of the separate notes sent into the line. As the complex or undulatory current passes through the coils of each harmonic receiver, that note only affects the particular armature that vibrates in unison with its ribbon or reed. The operator, therefore, at this receiver is in communication only with the operator at the key of the circuit that is sending this particular note into the line. The same is true of the other receivers.

The Morse alphabet is used in this system, the dots and dashes being received as musical tones. In practice it was found that there was no difficulty in each operator recognizing the particular sound of his own instrument in receiving, although many instruments were in the same room.

By a subsequent invention the signals received are converted into the regular Morse characters by means of an ingenious device.

Telegraphy, Induction — —A system for telegraphing by induction between moving trains and fixed stations on a railroad, by means of impulses transmitted by induction between the car and a wire parallel with the track.

Two systems of inductive telegraphy are in actual use, viz.,

(1.) The *Static Induction* system of W. W. Smith and Edison, and

(2.) The *Current* or *Dynamic Induction* system of Willoughby Smith and Lucius J. Phelps.

In the *System of Static Induction*, one of the condensing surfaces which receives or produces the charge, consists of a wire placed on the road so as to come as near the top of the cars of the moving train as possible. The other condensing surface is composed of the metal roofs of the moving cars.

Each condensing surface is connected to suitable instruments and batteries, and to the earth; the line wire at the fixed station being connected to earth through a ground plate, and the metal roof of the cars to earth through the wheels and track.

Under these circumstances variations in the charge of either of the condensing surfaces pro-

duce inductive impulses that are received by the other surface as telegraphic signals.

The Morse alphabet is employed, but in place of the ordinary receiver or sounder, a telephone is used.

In the *System of Current Induction*, the line wire is placed near the track, so as to be parallel with a coil of insulated wire placed on the side of the car, and which receives the inductive impulses. The coil of wire on the train is connected with instruments and batteries, and forms a metallic circuit. The line wire is also connected with suitable batteries and receiving and transmitting instruments.

An induction coil is generally employed, since the greater and more rapidly varying difference of potential of its secondary wire renders it better suited for producing effects of induction. A telephone is employed as a receiver, as in the system of static induction. The metallic car roof and the lower truss rods have been successfully used as the secondary conductor of the induction coil.

The automatic make-and-break used for operating the induction coil, causes the Morse characters employed in this system to be received in the receiving telephone as shrill buzzing sounds.

The receiving telephones used on the trains have a resistance of about 1,000 ohms.

Telegraphy, Induction, Current System of — —A system of induction telegraphy depending on current induction between a fixed circuit along the road, and a parallel circuit on the moving train.

The circuit on the train generally consists of a coil of wire. (See *Telegraphy, Induction*.)

Telegraphy, Induction, Dynamic System of — —A term sometimes used in place of a system of telegraphic current induction. (See *Telegraphy, Induction*.)

Telegraphy, Induction, Static System of — —A system of inductive telegraphy depending on the static induction between the sending and receiving instrument.

A fixed wire placed along the road so as to come near another wire or metallic surface on the moving train, imparts to the latter a static charge, which is utilized for the transmission of dispatches. The metal roof of the car is generally used for the condensing surface receiving the charge. (See *Telegraphy, Induction*.)

Telegraphy, Machine — — A term sometimes applied instead of automatic telegraphy. (See *Telegraphy, Automatic.*)

A system of telegraphy is properly called machine telegraphy when both the transmission and the receiving of the telegraphic messages are accomplished by machine, instead of by the hand, as usual.

Telegraphy, Morse System of — — A system of telegraphy in which makes and breaks occurring at intervals corresponding to the dots and dashes of the Morse alphabet are received by an electro-magnetic sounder or receiver.

A metallic lever A, Fig. 531, is supported on a pivot at G, between two set screws D, D, so as to have a slight movement in a vertical plane. This motion is limited in one direction by a stop at C, called the *anvil* or *front contact*, and in the other direction by a set screw F, which constitutes its *back stop*.

The front stop C, is provided with a platinum contact or stud, which may be brought into contact with, or separated from, a similar stud placed directly opposite it. These contacts are connected to the ends of the circuit so that on

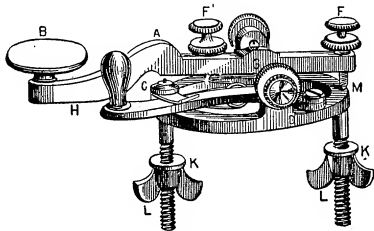

Fig. 531. Telegraphic Key.

the movements of the key, by the hand of the operator placed on the insulated head B, the line is closed and broken in accordance with the dots and dashes of the Morse alphabet. A spring, the pressure of which is regulated by the screw F', is provided for the upward movement of the key. A switch H, is provided for closing the line when the key is not in use.

The system generally used in the United States is known as the "Closed-Circuit System," the battery being connected to line whether the line is in use or not. This battery is generally placed at both ends of the line.

In Europe, the "Open-Circuit System" is gen-

erally used. Alternating currents and polarized relays are employed. One pole is connected to the line at the front of the key, and the other pole to the back of the key. When the line is not in use, it is connected to earth at both ends by switches conveniently placed for the operators. With this system, intermediate stations must each have a main battery, while in the closed-circuit system, the terminal batteries answer for all intermediate offices, which in some cases amount to as many as fifty.

In the Morse system, each station is provided with a key, relay, sounder or register, and local battery. The closed-circuit, connecting one station with another, being broken by the opening of the switch H, or the working of the key, so as to open and close its contacts, the armature of the relay opens or closes the circuit of the local battery and operates the sounder or registering apparatus connected therewith. (See *Sounder, Morse Telegraphic. Apparatus, Registering, Telegraphic.*)

Telegraphy, Multiplex — — A system of telegraphy for the simultaneous transmission of more than four separate messages over a single wire. (See *Telegraphy, Synchronous-Multiplex, Delany's System.*)

Telegraphy, Needle System of — — A system of telegraphy in which signals are transmitted by means of the movements of needles under the influence of the electric current. (See *Telegraphy, Single-Needle.*)

Telegraphy, Phonoplex — — A system of telegraphic transmission in which pulsatory currents, superposed on the ordinary Morse currents, actuate a modified telephonic receiver, and thus permit the simultaneous transmission of several separate messages over a single wire without interference.

Telegraphy, Printing — — A system of telegraphy in which the messages received are printed on a paper fillet.

In Callahan's Printing Telegraph, two type wheels are employed, one of which carries letter type and the other numerals on its circumference. These *printing wheels* are placed alongside of each other, as shown in Fig. 532, but on separate and independent axes.

The type wheels are moved by a step-by-step device. The impulses necessary to bring the

desired letters in position for printing are automatically sent by a circuit maker and breaker. These impulses are sent into the line by the depression of keys on a suitably arranged keyboard.

When the proper letter or numeral is reached at the receiving end, the printing wheel is stopped, and a paper fillet is pressed against its surface. The printing wheel is kept covered with ink by means of an inked roller.

The transmitting instrument is similar in its operation to the Breguet *manipulator*. Separate transmitters are used for each of the wires. (See *Telegraphy, Step-by-Step*.)

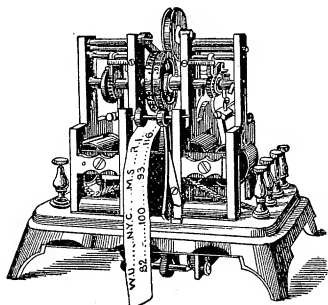

Fig. 532. Callahan's Printing Telegraph.

Telegraphy, Quadruplex — — A system for the simultaneous transmission of four messages over a single wire, two in one direction and the remaining two in the opposite direction.

Quadruplex telegraphy consists in fact of duplex telegraphy duplexed.

There are various systems of quadruplex telegraphy. The most important are the *bridge method* and the *differential method*. (See *Telegraphy, Quadruplex, Bridge Method of. Telegraphy, Quadruplex, Differential Method of.*)

Telegraphy, Quadruplex, Bridge Method of — — A system of quadruplex telegraphy by means of a double bridge duplex system. (See *Telegraphy, Quadruplex*.)

In the bridge method of quadruplex telegraphy, as in the differential method, changes in the polarity and strength of the current are utilized to establish a double duplex system of transmission. Fig. 533 from Prescott's "Electricity and Electric Telegraphy," from which the following description

is taken, shows the method first employed by the Western Union Telegraph Company in 1874.

A double current transmitter, or pole changer, is shown at T', with its operating key K' and local battery e'. This instrument interchanges the poles of the main battery E', when K, is depressed, and thus reverses the polarity of current on the line.

The increment transmitter T², is connected to the battery wire 12 of T', in such a way that when K', is depressed, the main battery E', is placed in series with battery E, of say twice the strength of E', thus permitting a current of three-fold the original strength to be sent into the line.

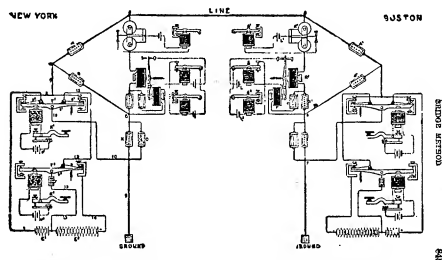

Fig. 533. Quadruplex Telegraphy, Bridge Method.

Two receiving instruments R' and R², are placed at the distant end of the line. R', is a polarized relay whose armature is deflected in one direction by positive currents, and in the opposite direction by negative currents, independently of their strength. That is to say, R', responds to changes in the direction of the currents that pass through its coils, but not to changes in their strength. (See *Relay, Polarized*.)

Relay R², is non-polarized and the movements of its soft iron armature depend on a change in the strength of the current only. That is to say, R², responds to changes in the strength of the current passing through its coils, but not to changes in their direction.

These two relays R and R², are placed in the bridge wire of a Wheatstone bridge. The entire apparatus of transmitting keys and relays is duplicated at each end of the line. Under these conditions, signals transmitted from either end of the line affect the instruments at the other end of the line, but not their own instruments, in the same manner as in the case of the *bridge duplex*. (See *Telegraphy, Duplex, Bridge Method of.*)

Telegraphy, Quadruplex, Differential

Method of — — A system of quadruplex telegraphy by means of a double differential duplex system.

Quadruplex telegraphy depends for its operation on the use of two differentially wound relays at each station. One of these relays A, as shown in Fig. 534, which shows the general arrangement of the system, gives signals on a change in the direction of the current, but none on a change in the current strength. The other B, gives signals on changes in current strength, but none on changes in direction. They are, therefore, independent of each other, and operate sounders that are under the independent control of two distinct receiving operators.

A table, divided into four sections, is provided with places for two sending and two receiving clerks. The name "A side" is given to the side worked by the reversed currents, and the "B side" to that worked by the strengthened currents.

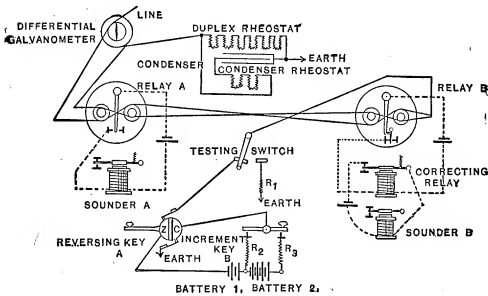

Fig. 534. Quadruplex Telegraphy, Differential Method.

Referring to Fig. 534 the reversing key on the "A side" is merely indicated so as to avoid confusion by too great detail; as is also the case with the increment key or the strengthening key at B. From the connections it will be seen that when the increment key is at rest, the reversing key sends currents from battery I. When the increment key is depressed, the reversing key is shifted from battery I, and connected by its copper connection C, with the battery 2, of double the strength of I. Since, however, I, is thus connected in series with C, the current strength is increased threefold.

From the reversing key the current passes to the junction of the two coils with which the relay B, is differentially wound. It divides here between these coils, which are connected to simi-

lar coils on relay A, as shown. The current from one coil on A, is sent to line, while that from the other coil goes to earth through the compensating rheostat. This arrangement forms a duplex system, the outgoing currents of which have no effect on the home relays.

Resistances R^2 and R^3 , are connected to the batteries 1 and 2, and the stops in the increment key in the manner shown, to the resistance of R^2 and R^3 . The former is used in order to maintain the resistance of the circuit, whether the battery is in or out of circuit. The latter is called the spark coil, and is intended to decrease the sparking on closing circuit.

When both are at rest, battery I, has its zinc connected to line through A, and its copper to earth through R^2 , C I, the lever of key B and key A, which last two are permanently connected. A reversed or spacing current goes to line, without affecting the home relays, since it passes in opposite directions and with equal strength through differentially wound coils.

When, however, the key A, is worked alone, it reverses the current and the signal is recorded by the distant relay A.

If key B, is worked alone, it breaks connection with copper at the junction of the two batteries, and makes contact with terminal copper of battery 2, so as to send a zinc current of threefold strength. The distant relay B, records a signal because the current is now strong enough to move it. Relay A, however, is not affected, since the current has not been reversed.

When both keys are simultaneously in action, then whenever B, is pressed, although the strength of A, may be increased, since its direction is not changed, the polarized tongue of its relay is unaffected by the movement of B, but any increase of current causes the armature of the distant relay of B, to move.

This armature is held in position by springs of such a strength as to prevent its motion by a weak current, and being unpolarized, responds to either positive or negative currents. It, therefore, responds to B, and records a signal. When A, is pressed, it reverses the current, and consequently moves the distant relay A, but has no effect on B, since it causes no alternation in the strength of the current.

The author has taken the above almost literally from Culley's "Handbook of Practical Telegraphy," to which the reader is referred for a fuller description and details of apparatus.

Telegraphy, Simplex — —A system of telegraphy in which a single message only can be sent over the line.

Telegraphy, Single-Needle — —A system of telegraphy by means of which the

of the observer represent the dashes, and movements to the left, the dots of the Morse alphabet.

The single-needle apparatus of Wheatstone and Cooke's system is shown in Figs. 535, and 536. Fig. 535, shows the external appearance, and Fig.

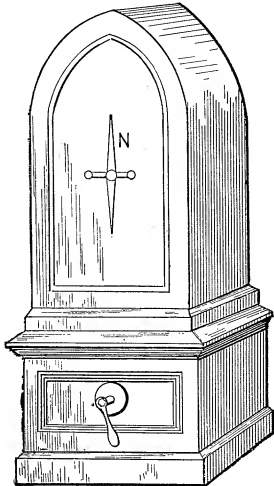

Fig. 535. Single-Needle Telegraphic Apparatus.

signals transmitted are received by observing the movements of a vertical needle over a dial.

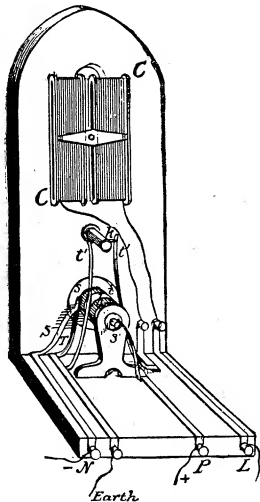

Fig. 536. Wheatstone and Cooke's Single-Needle Apparatus, Internal Arrangement.

Movements of the top of the needle to the right

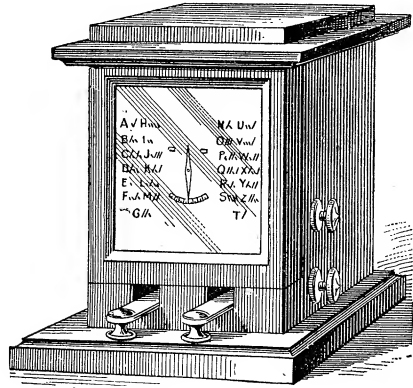

Fig. 537. Wheatstone and Cooke's Single-Needle Apparatus, External View.

536, the internal arrangements as seen from the back. An astatic needle is placed inside two coil of insulated wire C C. Only one of these needles N, is visible on the face of the receiving instrument. The current from the line enters at L, passes through the coil C C, and leaves at N.

The movements of the needle to the right or the left are obtained by changing the direction of the current in the coils C C. This is effected by working the handle when sending, and thus moving the commutator at S, S, and bringing the contact springs resting thereon into different contacts.

In the more modern form of single-needle instrument, shown in Fig. 537, a single magnetic needle N S, Fig. 538, only is placed in the coil.

This needle is rigidly attached to a light needle a, b, used only as a pointer, and is alone visible in the front of the instrument. The relative disposition of these needles is shown in Fig. 538.

The reversals of the current, required to deflect the needle to the right or left, are obtained by

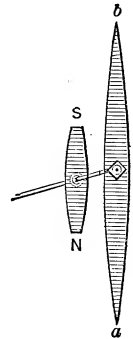
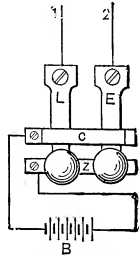

Fig. 538. Needle and Pointer.

means of a *double key* or *tapper*, shown in Fig. 539.

The levers L and E, are connected respectively to line and earth, and, when not in use, rest against C, connected with the positive side of the battery; but when depressed connect with Z, attached to the negative side of the battery.



The depression of L, therefore, sends a negative current into the line and deflects the needle, say, to the left, while the depression of E, sends a positive current into the line and deflects the needle Fig. 539. *Double* to the right. The terms *positive Key or Tapper*, and *negative currents* are used in telegraphy to indicate currents whose *direction* is positive or negative.

Telegraphy, Speaking — —A system for the telegraphic transmission of articulate speech. (See *Telephone*.)

Telegraphy, Step-by-Step — —A system of telegraphy in which the signals are registered by the movements of a needle over a dial on which the letters of the alphabet, etc., are marked.

Dial telegraphs are especially employed for communication by those who are unable to readily read the Morse characters.

The annexed instrument, devised by Breguet, was formerly used on some of the railway systems of France.

A needle advances over a dial by a step-by-step

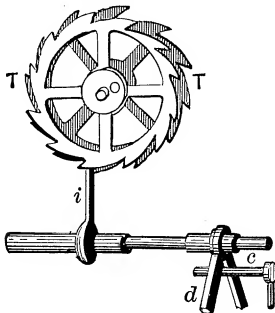

Fig. 540. Step-by-Step Wheel.

movement in one direction only. The alternate to-and-fro motions of the armature of an electro-magnet are employed to impart a step-by-step motion to a peculiarly shaped toothed wheel

T, T, Fig. 540, through the action of a horizontal arm c, attached thereto, and moving between the two prongs of a fork d, vibrating on a horizontal axis to which is attached a vertical pallet i.

The receiving instrument is called the *indicator*, and consists of a needle attached to the axis of this wheel. The needle moves over the face of

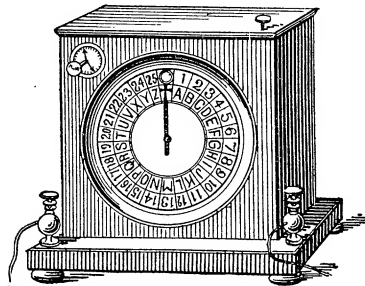

Fig. 541. Breguet's Indicator.

the dial, shown in Fig. 541, on which are marked the letters of the alphabet and the numerals.

The sending instrument is called the *manipulator*. It consists of a device for readily sending over the line the number of successive impulses required to move the needle step-by-step from any letter on the indicator to which it may be pointing, to the next it is desired to send.

The dial, shown in Fig. 542, is marked on its face with the same characters as the indicator. The edge of the wheel is provided with twenty-six notches in which a pin attached to a movable arm engages. The arm is jointed so that it can be placed in any of the notches on the face of the wheel.

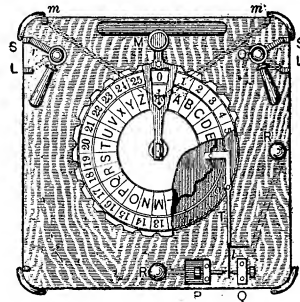

Fig. 542. Breguet's Manipulator.

Below the dial face, and attached to the same axis as the movable arm, is a wheel provided with undulations consisting of thirteen elevations and thirteen depressions.

A lever T, pivoted at a, rests in these undulations at its upper end, and plays between two contact points at P and Q.

If, now, the dials of the indicator and the manipulator both being at O, a movement is given to the arm by the handle M, to any point on the manipulator, there are thus produced the required number of makes and breaks to move the needle of the indicator to the corresponding letter or character.

Telegraphy, Submarine — —A system of telegraphy in which the line wire consists of a submarine cable.

In long submarine cables, in order to avoid *retardation* from the self-induction of the current, and the *static charge* arising from the cable acting as a condenser, very small currents are used. To detect these a very sensitive receiving instrument, such as the *mirror galvanometer*, or the *siphon recorder*, is employed. (See *Galvanometer, Mirror. Recorder, Siphon.*)

According to Culley, the retardation in the case of one of the submarine cables between Newfoundland and Ireland, amounts to *two-tenths of a second* before a signal sent from one end produces any appreciable effect at the other end, while *three-tenths of a second* are required for the current through the cable to gain its full strength.

Telegraphy, Synchronous-Multiplex, Delany's System — —A system devised by Delany for the simultaneous telegraphic transmission of a number of messages either all in the same direction, or part in one direction and the remainder in the opposite direction.

The Delany system embraces the following parts :

(1.) A circular table of alternately insulated and grounded contacts at either end of a telegraphic line.

(2.) A synchronized rotating arm or trailing contact, at each end of the line, driven by a *phonic wheel*, and maintained in synchronous rotation by means of electric impulses automatically sent out over the main line in either direction, on the failure of the wheel at either end to rotate synchronously with that at the other end.

(3.) Transmitting and receiving instruments connecting similar contacts at each end of the main line, and forming practically separate and independent lines for the simultaneous transmis-

sion of dispatches over the main line in either direction.

The main line is simultaneously connected at both of its ends to corresponding operating instruments, and transferred from one set of instruments to another so rapidly that the operators, either sending or receiving, cannot realize that the line has been disconnected from their instruments and given to others, because each of them will always have the line ready for use, even at the highest rate of manipulation, and will, therefore, to all practical intents and purposes, have at his disposal a private wire between himself and the operator with whom he is in communication.

Therefore, although more than one operator may be spoken of as simultaneously using the line at any given time, yet in reality no two operators are absolutely using it at the same time; but they follow one another at such short intervals, and the line is taken from one operator and transferred to another so rapidly, that none of them can at any time tell but that he has the line alone, and that therefore it is practically open for the use of every operator just as if he alone had control of it.

There will, therefore, be established, by the use of a single line, as many private and separate lines as there are transferences of the line from the time it is taken from the first operator, and again given back to him.

This system has been extended to as many as seventy-two distinct and separate printing circuits, maintained and operated on a single connecting line wire.

The speed at which the circuits may be operated is in the inverse order of the number of circuits organized. The best results, practically, are obtained from six divisions of the contacts in the circle, which gives each operator about 36 contacts with the line per second, a speed which admits of the highest rate of transmission on each of the six circuits.

Fig. 543 shows the apparatus at each end of the line, at the stations X and Y. The apparatus at each end is substantially identical. A steel fork a, at each station, is automatically and continuously vibrated by the action of the local battery L, B, and the electro-magnet A, called the *vibrator magnet*.

Platinum contacts x, x^1 , placed on the inner faces of the tines of the fork, make and break contact with delicate contact springs y, y^1 .

The fork being mechanically started into a vibratory motion, will automatically make and break its local circuit, and thus send impulses into the fork magnet A, that will continuously maintain the vibrations of the fork, in a well known manner.

The making and breaking of the contacts x and y, consequent on the fork's vibration, open and close another local battery placed in a circuit called the motor circuit, in which is also placed an electro-magnet D, the function of which is to maintain the continuous rotation of the transmission apparatus C.

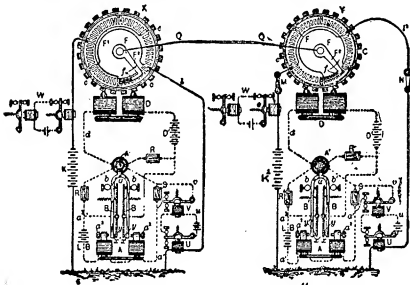

Fig. 543. Delany's Synchronous Multiplex Telegraph.

The continuous vibration of the fork makes and breaks the contacts at x and y, and thereby makes and breaks the motor circuit. The alternate magnetizations and demagnetizations of the cores of the motor-magnet D, cause the rotation of the transmission apparatus C.

The motor magnet and transmission wheel or disc C, provided with projections c, c, is the invention of Paul La Cour, and is styled by him a "phonic wheel."

The transmission apparatus is illustrated in detail in Figs. 544 and 545, and is an exact counterpart of the receiving apparatus at the other end of the line. A base plate E, provided with

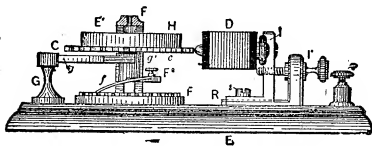

Fig. 544. The Phonic Wheel.

binding posts, carries a vertical rotary shaft F. A circular table F¹, is provided with a series of insulated contacts arranged symmetrically around the axis of rotation of the shaft. A radial arm F², connected with the shaft F, carries at its outer extremity a trailing contact finger f. As the

disc C, is rotated by the electro-magnet D, the trailing contact f, sweeps around the circular

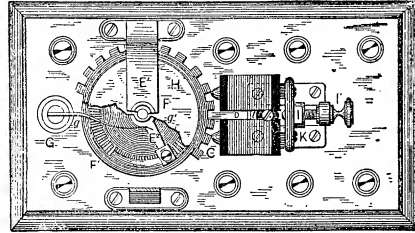

Fig. 545. The Phonic Wheel.

table F¹, and is brought successively into contact with the insulated contact pieces placed on the upper face of the table F¹.

The main line Q, Q, has one of its ends connected with the trailing finger f. As the shaft F, rotates, the line is therefore brought into successive electrical connection with the series of insulated contacts in the upper face of the table F¹.

Any suitable number of insulated contacts may be placed on the circular table F¹; sixty are shown in Fig. 546. In practice these contacts are connected in accordance with the number of circuits which it is desired to simultaneously maintain on the same wire. In the special case shown in the figure above referred to, it is arranged so that four separate circuits shall be established on the same line wire.

The sixty contacts are placed in six independent series, numbered from 1 to 10, consecutively. In the arrangement here shown two of the contact pieces in each series of ten are connected in the same circuit, and, as there are six series, each of the circuits so connected will have twelve contacts for each rotation of the disc, and twelve electrical impulses, as will be afterwards described.

The detailed mechanism, by means of which the separate and independent circuits so obtained are utilized for the transmission and reception of messages, is shown in Fig. 546. R, R¹, R² and R³, are polarized relays; S, S¹, S² and S³ are ordinary Morse sounders, although in the practice of this invention some improvement has been introduced in connection with the receiving instruments. The connections with the main and the local batteries M B and L B, are clearly shown in the figure.

It will be noticed that the relay R, is connected

with the wire r , and with the contacts 1 and 5; R^1 is connected by r^1 , with the contacts 2 and 6, R^2 , by the wire r^2 , with the contacts 3 and 7, and R^3 , by the wire r^3 , with the contacts 4 and 8. Similar instruments and circuits are placed at each end of the line.

Without further describing the operation of the instruments shown in the figure, it need only now be borne in mind that the corresponding relays at the distant stations are connected with the correspondingly numbered contacts. When, therefore, the trailing contact finger at each station simultaneously touches the contacts bearing the same number, the corresponding instruments connected

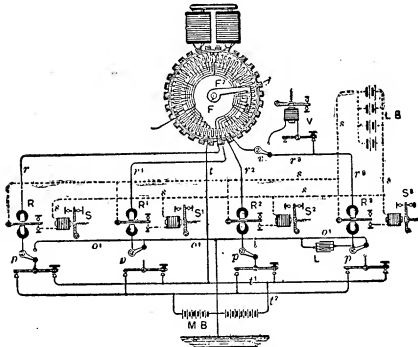

Fig. 546. Working and Receiving Currents.

with these contacts at each station will be placed in communication over the main line, the trailing contact finger f , completing the connection of the main line with the contact arm in the manner already described.

Telegraphy, Time — — A system for the telegraphic transmission of time.

A system of time telegraphy includes a *master clock*, the movements of whose pendulum automatically transmit a number of electric impulses to a number of *secondary clocks* and thus moves them; or self-winding clocks are employed, which are corrected daily by an impulse sent over the line from a master clock. (See *Clock, Electric*.)

Telegraphy, Writing — — A species of fac-simile telegraphy, by means of which the motions of a pen attached to a transmitting instrument so vary the resistance on two lines connected with a receiving instrument as to cause the current received thereby to reproduce the motions, on a pen or stylus, which transfers them to a sheet of paper.

A system of writing telegraphy consists essentially of transmitting and receiving instruments connected by a double line wire.

The transmitting instrument is shown in Fig. 547.

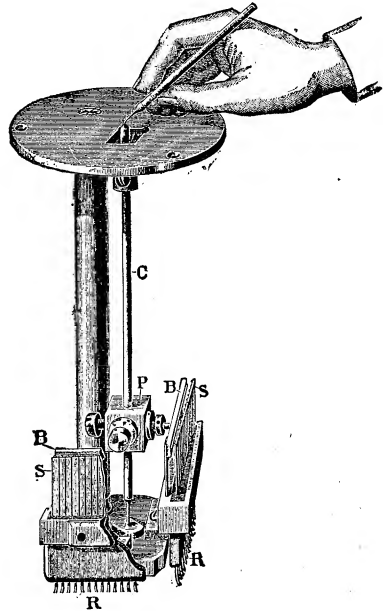

Fig. 547. Transmitter of Writing Telegraphy.

A stylus or pen resting on a top plate, is connected by the rod C , with a series of steel contact springs S, S , secured to the base and placed at right angles to one another. A series of resistances R, R , are connected with the lower ends of these contact springs. Two contact bars, B, B , are provided on the side facing the springs with platinum contacts opposite the contacts on the springs. The stylus rod C , is securely fixed to the base, but a spring at the lower end permits of its free movement. A pressure block at P , is fastened to the stylus rod, as shown, and in its normal position the pressures are adjusted so that contact is secured with the first spring.

A movement of the stylus, as in writing, presses the contact bar against the spring, varying the position and number of contacts, and thereby cutting in or out the resistance necessary to effect the proper movement of the receiving pen.

The receiving instrument is shown in Fig. 548. It consists of two electro-magnets placed at right angles to each other. A double armature sup-

ports the receiving stylus or pen in the manner shown. The variations in the current sent over the line by the varying resistances introduced into the circuit, or cut out or in by the action of the transmitting stylus, causes variations in the position of the double armature, under the varying magnetic attraction of the receiving electromagnet, and thus causes the receiving pen to correctly reproduce the motions of the transmitting pen.

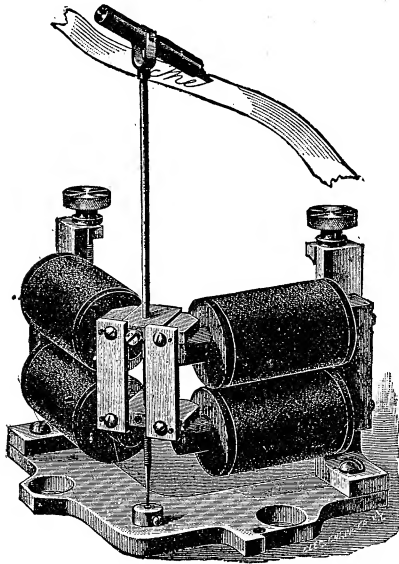

Fig. 548. Receiver of Writing Telegraph.

This system has been operated over a line nearly 500 miles in length, when it successfully reproduced written characters.

The author is indebted for the drawings and the general facts to the *Electrical Engineer* of New York.

Tele-Hydro-Barometer, Electric — —

An apparatus for electrically transmitting to, and recording at a distant station the height of water or other liquid.

Tele-Manometer, Electric — —

A gauge for electrically indicating and recording pressure at a distance.

The tele-manometer includes a pressure gauge furnished with electric contacts operated by the movements of the needle of the steam gauge, for instance, and indicating and recording apparatus. An alarm bell is provided to call attention to any

rise of the pressure above or its fall below the given or predetermined limits for which the hands have been set.

Telemeter.—An apparatus for electrically indicating and recording at a distance the pressure on a gauge, the reading of a thermometer, or the indications of similar instruments. (See *Tele-Hydro-Barometer, Electric. Tele-Manometer, Electric. Tele-Thermometer, Electric.*)

Telephone.—To communicate by means of a telephone.

Telephone.—An apparatus for the electric transmission of articulate speech.

The articulating telephone, though first brought into public use by Bell, was invented by Reis, in Germany, in 1861. In America, after very protracted litigation, Bell has been decided legally to be the first inventor, but scientific men very generally recognize the principles of the invention to be fully anticipated by the earlier instruments of Reis. Bell, however, is justly entitled to the credit of inventing the first really successful telephone.

In Bell's *magneto-electric telephone*, the transmitting and receiving instruments are identical. A coil C, of insulated wire connected with the line, is placed on a core of magnetized steel, mounted opposite the centre of a circular diaphragm of thin sheet iron, rigidly supported at its edges.

In transmitting, the message is spoken into the mouth-piece at one end, as at D, in Fig. 549, and

the to-and-fro motions thus imparted to the metallic diaphragm attached to the mouth-piece P, produce *induction currents* in the coil C, on the magnet M. (See *Induction, Electro-Dynamic.*) These impulses, passing over the main line E L, Fig. 550, produce similar movements in the diaphragm P', of the receiving instrument, at D', and thus cause it to reproduce the message, in articulate sounds, to one listening at the receiving instrument. A ground circuit is shown in the figure, as usually employed in practice, except for long distance and in large cities.

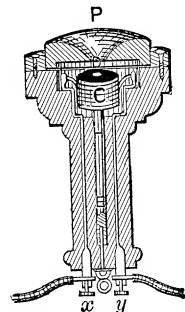

Fig. 549. Telephone.

A magneto-telephone constitutes in reality a magneto-electric machine, driven or propelled by the voice of the speaker, in which the currents so produced instead of being commuted are employed uncommuted to reproduce the uttered speech.

In actual practice the instrument above described is replaced by the *electro-magnetic tele-*

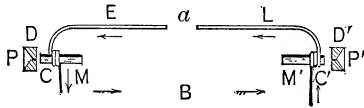
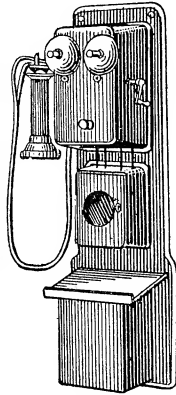

Fig. 550. Telephone Circuit.

phone, in which the to-and-fro motions of the transmitting diaphragm are caused to vary the resistance of a *button of carbon*, or a *variable contact transmitter* similar to that employed by Reis in some of his instruments. The variable resistance is placed in the circuit of a battery, so that on speaking into the transmitter, electric impulses are sent over the line and are received by a telephone with a *magnet core* provided with a coil in the main-line circuit.

The telephone is arranged for actual commercial use in the United States in the manner Fig. 551. Telephone Apparatus. shown in Fig. 551.



Telephone, Bi — — A term sometimes applied to a double telephone receiver so arranged as to permit of easy application to both ears of the listener at the receiving instrument.

Telephone Cords.—(See *Cords, Telephone.*)

Telephone, Electro-Capillary — — A telephone in which the movements of the transmitting diaphragm produce currents by means of variations in the electromotive forces of the contact surfaces of liquids in capillary tubes. (See *Phenomena, Electro-Capillary.*)

In Breguet's telephone both the transmitting and the receiving instruments are similar in con-

struction and operate by means of electro-capillary phenomena. A vertical capillary tube communicates at its upper end with an air space below a diaphragm, and at its lower end with a mercury surface on which rests a layer of acidulated water.

A line wire connects the mercury reservoirs of the transmitting and receiving instruments, the remainder of the circuit being formed by another wire connecting the mercury near the upper parts of the two vertical tubes.

The alterations in the contact surfaces at the transmitting end produced by the movements of the diaphragm, cause electric impulses that produce similar movements of the diaphragm at the receiving end.

Telephone, Electro-Chemical — — A name sometimes given to the Edison electro-motographic telephone. (See *Telephone, Electro-Motographic.*)

Telephone, Electro-Motographic — — A telephone in which the receiver consists of a diaphragm of mica or other elastic material operated on the principle of the electro-motograph.

A straight lever, which forms part of the line circuit, is rigidly attached at one end to the centre of the receiving diaphragm, and rests near its other end on the surface of a chalk cylinder moistened with a solution of caustic potash or potassium iodide, maintained in rotation by suitable mechanical means.

Electric impulses being sent into the line by the voice of a speaker talking at a transmitter of ordinary construction reduce the friction between the lever and the cylinder, and produce slipping movements of the lever that reproduce articulate speech in the receiving diaphragm.

Telephone, Reaction — — An electro-magnetic telephone in which the currents induced in a coil of wire attached to the diaphragm are passed through the coils of the electro-magnet, and thus react on and strengthen it.

Telephone Switch, Automatic — — (See *Switch, Telephone, Automatic.*)

Telephonic.—Pertaining to the telephone.

Telephonic Alarm.—(See *Alarm, Telephonic.*)

Telephonic Cable.—(See *Cable, Telephonic*.)

Telephonic Exchange.—(See *Exchange, Telephonic, System of*.)

Telephonic Exchange, System of — — (See *Exchange, Telephonic, System of*.)

Telephonic Joints.—(See *Joint, Telegraphic or Telephonic*.)

Telephonically.—In the manner of the telephone. (See *Telephone*.)

Telephoning.—Communicating by means of the telephone.

Telephote.—An apparatus for the telegraphic transmission of pictures by means of the action of light on selenium. (See *Telephotography*.)

The telephote is sometimes called the pherope.

Telephotography.—A system for facsimile transmission by means of dots and lines transmitted by means of a continuous current whose intensity is varied by a transmitting instrument containing a selenium resistance. (See *Telegraphy, Fac-Simile, Resistance or Cell, Selenium*.)

The transmitter consists of a dark box mounted on an axis, so as to be capable of a sidewise motion. The picture to be transmitted is thrown continuously on the face of the box by any lantern projection apparatus, and a small opening containing a selenium resistance receives

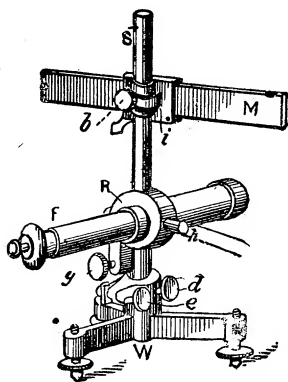

Fig. 552. Reading Telescope.

the alternations of light and shade, and transmits the same as variations in the strength of the other-

wise continuous current in the circuit of which the selenium resistance is placed.

The picture is received at the other end on a sheet of chemically prepared paper moved synchronously with the transmitting box.

Telescope, Reading — — A telescope employed in electric measurements for reading the deflections of the galvanometer.

The image of numbers on an illumined scale is seen in the mirror through the telescope, shown in Fig. 552.

Teleseme.—A self-registering hotel annunciator, by means of which a dial operated in a room indicates on the annunciator the article or service required.

Tele-Thermometer, Electric — — An electric recording thermometer for indicating and recording temperature at a distance.

The tele-thermometer consists essentially of a transmitter and a receiver. The transmitter consists of a delicate thermometer provided with suitable contacts. The receiver, which is in circuit with the transmitter, has, in some forms, a recording dial on which a continuous record, for a day or week, is made. In cases where it is desired that a given maximum temperature shall not be exceeded, an alarm bell, connected with contacts on the dial face, is rung.

Telluric Magnetic Force.—(See *Force, Magnetic, Telluric*.)

Telpher Line.—(See *Line, Telpher*.)

Telpherage.—A system for the conveyance of carriages suspended from electric

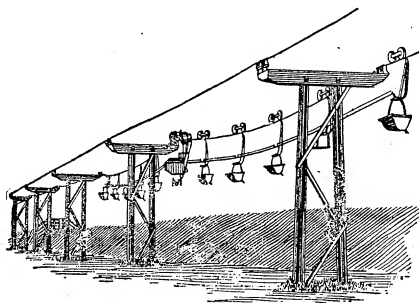

Fig. 553. Circuit for Telpherage System.

conductors, and driven by means of electric motors, that take directly from the conductors the current required to energize them.

Two lines are provided, an *up* and a *down* line, that cross each other at regular intervals. Each line is in segments, and the alternate segments are insulated from each other, but are connected electrically by cross-pieces on the supporting posts. In this way the line shown in Fig. 553 is obtained.

The two lines are maintained at a difference of potential by a dynamo-electric machine at D, Fig. 554. As the train at L T, or L' T', is of such a length as to come into contact with two different segments at the same time, it receives a current sufficient to run the motor connected with it, the current being received through a conductor joining a pair of wheels that are insulated from the truck.

The general arrangement of the line is shown in the annexed Fig. 554

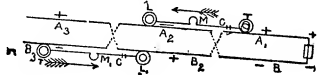

Fig. 554. Circuit for Telpherage System.

Temperature Alarm.—(See *Alarm, Temperature.*)

Temperature, Effects of, on Electric Resistance — —(See *Resistance, Effect of Heat on Electric.*)

Tempering, Electric — —A process for tempering metals in which heat of electric origin is employed instead of ordinary furnace heat.

Temporary Intensity of Magnetization.—(See *Magnetization, Temporary Intensity of.*)

Tension, Electric — —A term often loosely applied to signify indifferently surface density, electromotive force, dielectric stress, or difference of potential.

This term is now very generally abandoned.

Terminal, Cable — —A water-tight covering provided at the end of a cable to prevent injury to the cable insulation by the moisture of the air.

Terminal, Negative — —The negative pole of a battery or other electric source, or the end of the conductor or wire connected with the positive plate.

Terminal, Positive — —The positive pole of a battery or other electric source, or the end of the conductor or wire connected to the negative plate.

Terminals.—A name sometimes applied to the poles of a battery or other electric source, or to the ends of the conductors or wires connected thereto.

The two terminals are distinguished as the *positive* and the *negative*. Their names are unlike those of the battery plates to which they are connected, the positive terminal being connected with the negative plate and the negative terminal with the positive plate.

Terrestrial Magnetism.—(See *Magnetism, Terrestrial.*)

Testing, Methods of — —Various methods for determining the values of the current strength in any circuit, the difference of potential, the resistance, the coulombs, the farads, the joules, the watts, etc. (See *Measurements, Electric.*)

The investigation of an apparatus or circuit for the purpose of determining whether it is in standard or working condition.

Testing of Joints.—(See *Joint, Testing of.*)

Testing Pole.—(See *Pole, Testing.*)

Testing Transformer.—(See *Transformer, Testing.*)

Tetanus.—Continuous, spasmodic contraction of the muscles.

Tetanus, Acoustic — —Tetanus produced in a muscle by means of alternate currents induced in a coil of wire by a magnetized steel spring vibrating near the coil with sufficient rapidity to give a musical note.

The rapidity of the inductive shock can be determined from the pitch of the musical note; hence the use of the term acoustic.

Theatrophone.—A system of telephonic communication between theatres or operas and subscribers, by means of slot machines.

Any person at a café, club, restaurant or other public place, by the theatrophone, is automatically placed in communication with the theatre by means of a receiving telephone so as to hear

the performance by dropping a given piece of money in the slot of the machine.

Theodolite, Magnetic — —An apparatus for measuring the declination or variation of the magnetic needle at any place.

A divided circle, like that on a theodolite, is supported horizontally. The needle is formed of a tubular magnet, having an achromatic lens at one end and a scale at the focus of the lens at the other end.

Theory, Alternation, of Muscular Nerve Current — —A theory proposed by L. Hermann, in which the currents of nerves or muscular fibres are regarded as a result of their alteration from an original condition.

Hermann states:

(1.) That protoplasm undergoing partial death at any part, either while dying or by metamorphosis, becomes negative to the uninjured part.

(2.) Protoplasm, when excited at any part, becomes negative to the unexcited part.

(3.) Protoplasm, when partially heated at any part, becomes positive, and, on cooling, negative to the unchanged part.

(4.) Protoplasm is strongly polarizable on its surface, the polarization constantly diminishing with excitement and while dying.

According to this theory, passive, uninjured and absolutely fresh tissues are devoid of electric currents. This matter must still be regarded as unsettled. (See *Theory, Molecular, of Muscles or Nerve Current.*)

Theory, Contact, of Voltaic Cell — — (See *Cell, Voltaic, Contact Theory of.*)

Theory, Difference — —A theory as to the cause of the electric currents excited between injured and uninjured protoplasm.

Theory, Molecular, of Muscles or Nerve Current — —A theory proposed by Du Bois Reymond, in which every nerve or muscular fibre is regarded as composed of a series of electromotive molecules arranged in series and surrounded by a neutral conducting fluid.

"The molecules are supposed to have a positive equatorial zone directed towards the surface and two negative polar surfaces directed toward the transverse section. Every fresh transverse section exposes new negative surfaces, and every

artificial longitudinal section new positive area." —(*Landois and Sterling.*)

Theory of Electric Displacement.—(See *Displacement, Electric, Theory of.*)

Therapeutical Electrization.—(See *Electrization, Therapeutical.*)

Therapeutic Bath, Electro — —(See *Bath, Electro-Therapeutic.*)

Therapeutics, Electro, or Electro-Therapy — —The application of electricity to the curing of disease. (See *Biology, Electro.*)

Therapist, Electric — —One skilled in electro-therapy.

An electro-medical practitioner.

Therapy, Electro — —A term sometimes used instead of electro-therapeutics. (See *Therapeutics, Electro, or Electro-Therapy.*)

Therapy, Magneto — —Alleged electro-therapeutic effects produced by the movements of magnets over the body of the patient.

It is asserted by eminent authorities that such effects have an actual existence. They should, however, until more carefully investigated, be accepted with extreme caution.

Therm.—A heat unit proposed by the British Association.

A therm is the amount of heat required to raise the temperature of one gramme of pure water at the temperature of its maximum density one degree centigrade. (See *Calorie.*)

Thermaesthesiometer.—An instrument employed in electro-therapeutics for testing the temperature sense in nervous diseases.

The thermaesthesiometer consists of two thermometers movable on a standard, with flat vessels of mercury in order to readily apply them to the skin. The mercury vessel of one of the two thermometers is surrounded by an insulated platinum wire and may be warmed at pleasure by passing a galvanic current through the wire.

The two vessels, brought to different temperatures, are set on the same part of the skin, one after the other, so as to test the sensibility of the skin for the differences in temperature.

Thermal Absorption.—(See *Absorption, Thermal.*)

Thermal Caутery.—(See *Caутery, Thermal*.)

Thermal Incandescence.—(See *Incandescence, Thermal*.)

Thermic Balance.—(See *Balance, Thermic, or Bolometer*.)

Thermo-Battery.—(See *Battery, Thermo*.)

Thermo Call.—A call operated by means of thermo currents.

Thermo-Cell.—(See *Cell, Thermo-Electric*.)

Thermo-Electric Battery.—(See *Battery, Thermo-Electric*.)

Thermo-Electric Cell.—(See *Cell, Thermo-Electric*.)

Thermo-Electric Couple.—(See *Couple, Thermo-Electric*.)

Thermo-Electric Diagram.—(See *Diagram, Thermo-Electric*.)

Thermo-Electric Effect.—(See *Effect, Thermo-Electric*.)

Thermo-Electric Inversion.—(See *Inversion, Thermo-Electric*.)

Thermo-Electric Pile, Differential —
—(See *Pile, Thermo, Differential*.)

Thermo-Electric Pile or Battery.—(See *Pile, Thermo-Electric*.)

Thermo-Electric Power.—(See *Power, Thermo-Electric*.)

Thermo-Electric Series.—(See *Series, Thermo-Electric*.)

Thermo-Electricity.—(See *Electricity, Thermo*.)

Thermo-Electrometer.—A name sometimes, but not happily, applied to an electric thermometer. (See *Thermometer, Electric*.)

Thermo-Electromotive Force.—(See *Force, Electromotive, Thermo*.)

Thermolysis.—A term applied to the chemical decomposition of a substance by heat.

Thermolysis, or dissociation, is an effect produced by an action of heat somewhat similar to the effect of electrolysis, or chemical decomposition produced by the passage of an electric current. When a chemical substance is heated, the

vibration of its molecules is attended by an interatomic vibration of its constituent atoms so that a decomposition ensues. If the temperature is not excessive, these liberated atoms recombine with others which they meet. At higher temperatures, however, such recombination is impossible, and a permanent decomposition ensues, called thermolysis or dissociation.

Thermometer, Electric — —A device for determining the effects of an electric discharge by the movements of a liquid column on the expansion of a confined mass of air through which the discharge is passed.

Thermometer, Electric Resistance — —
—A thermometer the action of which is based on the change in the electric resistance of metallic substances with changes in temperature.

The electric resistance thermometer is used, among other purposes, for determining the temperature of the sea at different depths. Its operation is based on the electric resistance of two perfectly similar coils of insulated wire, enclosed in separate water-tight copper cases. One coil is placed where the temperature is to be determined, and the other in a vessel of water, the temperature of which is altered until the two coils show the same resistance, when, of course, the temperature of the distant coil is the same as that of the water surrounding the other coil.

Thermometer Scale, Centigrade — —
(See *Scale, Thermometer, Centigrade*.)

Thermometer Scale, Fahrenheit — —
(See *Scale, Thermometer, Fahrenheit*.)

Thermophone.—Any instrument by means of which sounds are produced by the absorption of radiant energy. (See *Photophone*.)

A telephone has been constructed in which the motions of the receiving diaphragm are effected by the expansions and contractions of a thin metallic wire connected to the diaphragm and placed in the circuit of the main line.

Thermostat.—An instrument for automatically maintaining a given temperature by the closing of an electric circuit through the expansion of a solid or liquid.

Thermostats are often used in systems of automatic fire telegraphy and in systems of automatic temperature regulation in connection with indi-

ating instruments for sounding an alarm or giving notice when the temperature changes.

They are operated either on open or closed circuits.

Thermostat Alarm.—(See *Alarm, Thermostat.*)

Thermostat, Closed-Circuit — — A thermostat maintained normally on a closed circuit.

In closed-circuit thermostats, the adjustment for any degree of temperature within a given range is effected by means of a screw.

Thermostat, Electro-Pneumatic — —

An instrument for automatically indicating the existence of a given temperature by the closing of an electric circuit on the expansion of a gas.

Thermostat, Mercurial — — A thermostat operating by the expansion of a mercury column.

A mercurial thermostat is shown in Fig. 555. One terminal is connected directly with the mercury; the other is placed in the arm to the left. On a certain predetermined temperature being reached, the rise of the mercury column completes the circuit and rings an alarm bell. By connecting the thermostat with an annunciator, the particular locality where an excessive temperature has been reached is indicated. Such a system is in use in a well known system of fire alarm.

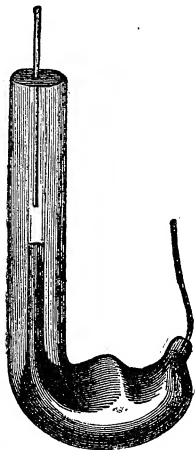

Fig. 555. Mercurial Thermostat.

Thermostat, Open-Circuit — — A thermostat maintained normally on an open circuit.

In open-circuit thermostats the adjustment for temperature within a given range is effected by varying the distance of the fixed and movable contact points.

Thermostatic.—Of or pertaining to a thermostat. (See *Thermostat.*)

Thomson's Gauss.—(See *Gauss, S. P. Thompson's.*)

Thomson's Gauss.—(See *Gauss, Sir William Thomson's.*)

Three-Branched Sparks.—(See *Spark, Three-Branched.*)

Three-Filament Incandescent Electric Lamp for Multiphase Circuits.—(See *Lamp, Electric, Incandescent, Three-Filament, for Multiphase Circuits.*)

Three-Way Trolley Frog.—(See *Frog, Trolley, Three-Way.*)

Three-Wire System.—(See *System, Three-Wire.*)

Throttling.—Choking, or stopping off.

Through Circuit.—(See *Circuit, Through.*)

Through Line.—(See *Line, Through.*)

Throwback Indicator, Electrical — — (See *Indicator, Electric Throwback.*)

Throwback Indicator, Mechanical — — (See *Indicator, Mechanical Throwback.*)

Throw of Needle.—(See *Needle, Throw of.*)

Thumb-Cock Electric Burner.—(See *Burner, Thumb-Cock Electric.*)

Thunder.—A loud noise accompanying a lightning discharge.

Thunder is due to the sudden rush of the surrounding air to fill the partially vacuous space accompanying the disruptive discharge of a cloud. This space is caused mainly by the condensation of the vapor formed on the passage of the discharge through drops of rain or moisture in the air, as well as by the expansion of the air itself.

Thunder Rod.—(See *Rod, Thunder.*)

Thunder Storms, Geographical Distribution of — — (See *Storms, Thunder, Geographical Distribution of.*)

Tick, Magnetic — — A faint metallic click heard on the magnetization and demagnetization of a magnetizable substance.

Ticker Service, Stock — — The simultaneous transmission of stock quotations or other desired information to a number of subscribers.

The stock ticker-service includes a central transmitting station connected with a given num-

ber of subscribers, each of whom is furnished with a stock ticker. The transmitter at the central station consists of a keyboard and a cylinder furnished with spiral pins. The spiral pins are connected through a series of pole-changers to separate line wires radiating in all directions from the central office.

The connections are such that, a rapid rotation being given by means of an electric motor to the cylinder, the impulses sent out by the keyboard are transmitted to each of the separate circuits. Since each of these circuits has a number of ticker printers connected with it, reports of fluctuations in prices are simultaneously printed in hundreds of different offices.

Ticker, Stock — —A form of step-by-step telegraphic instrument employed for automatically sending and recording stock quotations to any desired number of subscribers. (See *Telegraphy, Step-by-Step*.)

A form of printing telegraph.

Callahan's Printing Telegraph is used as a stock ticker. (See *Telegraphy, Printing*.)

Phelps' Stock Printer is employed extensively as a stock ticker. This form of printing telegraph requires but a single wire, and has a working speed of almost thirty words a minute.

A double type-wheel, maintained in motion by clockwork, is stopped at the desired characters by the motion of a polarized relay, working between the poles of two electro magnets, furnished with a soft iron or non-polarized armature. The release of the armature of the printing magnet releases a train, and thus insures the impression of the character it is desired to print.

The type-wheel is driven by a step-by-step movement obtained by means of rapidly alternating pulsations. Although these pass through the coils of the printing magnet, they follow one another too rapidly to charge its coils, so that the armature is unaffected until a pause is made, when, its armature being attracted, it releases the printing mechanism. The message is received on a fillet of paper, fed by a suitable mechanism.

Time-Ball, Electric — —(See *Ball, Electric Time*.)

Time-Constant of Circuit.—(See *Circuit, Time-Constant of*.)

Time-Constant of Condenser.—(See *Condenser, Time-Constant of*.)

Time-Constant of Electro-Magnet.—(See *Constant, Time, of Electro-Magnet*.)

Time Cut-Out, Automatic — —An automatic cut-out arranged on a storage battery so as to cut it in or out of the circuit of the charging source at predetermined times.

Time-Fall of Electromotive Force of Secondary or Storage Cell During Discharge.—(See *Force, Electromotive, of Secondary or Storage Cell, Time-Fall of*.)

Time-Lag of Magnetization.—(See *Magnetization, Time-Lag of*.)

Time, Reaction — —The time required for the effects of an electric current to pass from a nerve to a muscle.

Time-Rise of Electromotive Force of Secondary or Storage Cells During Discharge.—(See *Force, Electromotive, of Secondary or Storage Cell, Time-Rise of*.)

Time-Switch.—(See *Switch, Time*.)

Time, Telegraphic, Register for Railroads — —(See *Register, Time, for Railroads*.)

Time Telegraphy.—(See *Telegraphy, Time*.)

Tinned Wire.—(See *Wire, Tinned*.)

Tinning, Electro — —Covering a surface with a coating of tin by electro-plating. (See *Plating, Electro*.)

Stannic chloride, or the perchloride of tin, dissolved in water in the proportion of 30 parts of the salt to 1,250 of water, makes a good tinning bath.

Tinnitus, Telephone — —A professional neurosis, or abnormal nervous condition of the auditory apparatus, believed to be caused by the continual use of the telephone.

Tips, Polar — —The free ends of the field magnet pole pieces of a dynamo-electric machine.

Tissue, Nerve or Muscular Excitability of — —Electric stimulation of nervous or muscular tissue.

The general effects of electric stimulation of nervous or muscular tissue may be summarized as follows:

(1.) Electric stimulation of a motor nerve, produces a contraction of the muscles to which such nerve is distributed.

(2.) Electric stimulation of a sensory nerve, produces pain in the parts to which the nerve is distributed.

(3.) Electric stimulation of mixed motor and sensory nerves produces both of the effects mentioned under (1) and (2.)

Tongs, Cable Hanger — —Tongs provided with long handles for the purpose of attaching the hangers of an aerial cable to the suspending wire or rope.

Tongs, Discharging — —A term sometimes used for a discharging rod. (See *Rod, Discharging*.)

Tongue, Relay, Bias of — —A term employed to signify such an adjustment of a polarized relay, that on the cessation of the working current, the relay tongue shall always rest against the insulated contact, and not against the other contact, or vice versa.

Sometimes, as in the split-battery duplex, the bias is toward the uninsulated contact. (See *Relay, Polarized*.)

Tool, Lead Scoring — —A tool for readily scoring the surface of the lead of a lead-covered cable, when the same is to be removed preparatory to making joints.

Toothed-Ring Armature.—(See *Armature, Toothed-Ring*.)

Top, Induction — —A top consisting of an iron disc supported on a vertical axis, which, when spun before the poles of a steel magnet, assumes an inclined position, through the influence of the currents induced in the disc.

The top maintains the inclined position so long only as the strength of the induced currents is sufficiently great; that is, while speed of rotation is sufficiently great.

Töppler-Holtz Machine.—(See *Machine, Töppler-Holtz*.)

Torch, Electric Gaslighting — —A gaslighting appliance consisting of the com-

bination of a portable voltaic battery and a spark or induction coil.

The torch is mounted on the end of a rod provided with means for turning on the gas. A key is then touched and the gas lighted by the spark produced by an induction coil or a small electrostatic induction machine.

Torpedo, Automobile — —A torpedo which contains in itself the power for its own motion.

The moving power may be that derived from compressed air or gas, or from a storage battery contained within the torpedo. An automobile torpedo provided with a storage battery and electric motor would then be distinguished from an electrically propelled torpedo, connected by means of cables with a driving dynamo located outside the torpedo on a ship, or on the shore.

Torpedo Boat.—(See *Boat, Torpedo*.)

Torpedo Cable.—(See *Cable, Torpedo*.)

Torpedo, Drifting — —A torpedo suspended from a float, and connected by means of rope with similar torpedoes, allowed to drift with the current, so as to catch against a vessel.

Torpedo, Electric — —A name sometimes given to the electric ray. (See *Ray, Electric*.)

Torpedo, Electric — —An electrically operated torpedo.

This latter usage of the term is the commoner.

Torpedo, Halpine-Savage — —A special form of torpedo, in which electricity is both the propelling and directing power, and in which the electric source furnishing the propelling current is contained within the torpedo.

In the Halpine-Savage torpedo, the propelling power is obtained from a storage battery placed within the torpedo.

Torpedo, Lay — —A moving torpedo, in which the moving power is carbonic acid gas, or compressed air, or other similar power not electric, and the guiding power is electric.

The Lay torpedo has the form of a cylindrical boat furnished with conical ends. The explosive is placed in the fore part of the torpedo. Flags are

attached to the torpedo, showing the operator the exact course taken by it.

The torpedo is started, stopped and steered by means of electric currents sent to the torpedo through an insulated cable connected with the torpedo.

Torpedo Nets.—(See *Nets, Torpedo.*)

Torpedo, Outrigger — —A pole or spar torpedo.

The torpedo is placed in a metallic case and supported on the end of a spar or outrigger. The spar is depressed until the torpedo is sunk below the water line. The torpedo is fired when its end comes in contact with the side of the enemy's vessel.

Torpedo, Sims-Edison — —A special form of torpedo in which electricity is both the propelling and the directing power, but the electric source is situated outside of the torpedo.

The torpedo is propelled by means of an electric motor placed in the torpedo, and driven by means of an electric current transmitted through a cable connected with the sending station.

Torpedo, Spar — —A torpedo, attached to the end of a spar, and designed to be exploded by percussion against the side of an enemy's vessel, when thrust against the side below the water-line.

The spar torpedo is but little used, having been replaced by more efficient forms.

Torpedo, Stationary — —A term sometimes employed instead of a submarine mine. (See *Mine, Submarine.*)

A stationary torpedo is so named in order to distinguish it from a torpedo which is moved through the water by any means. (See *Torpedo, Towing.*)

Torpedo, Towing — —A torpedo arranged to be towed on the surface after a vessel and explode when it strikes the side of an enemy's vessel.

The torpedo is shaped so that it maintains during its motion a certain distance from the sides of the towing boat or vessel.

Torque.—That moment of the force applied to a dynamo or other machine which turns it or causes its rotation.

The mechanical rotary or turning force which acts on the armature of a dynamo-electric machine or motor and causes it to rotate.

In the case of the armature of a dynamo-electric machine the torque is equal to the radius of the armature, multiplied by the pull at the circumference, or the radius of its pulley multiplied by the pull at the circumference of the pulley.

A torque is exerted on the shaft of a motor from the electro-magnetic action, or pull at the periphery of the armature.

The torque is usually measured in pounds of pull at the end of a radius or arm 1 foot in length.

Torriceilian Vacuum.—(See *Vacuum, Torricellian.*)

Torsion Balance, Coulomb's — —(See *Balance, Coulomb's Torsion.*)

Torsion Galvanometer.—(See *Galvanometer, Torsion.*)

Total Disconnection.—(See *Disconnection, Total.*)

Total Earth.—(See *Earth, Total.*)

Total Magnetic Induction.—(See *Induction, Total Magnetic.*)

Touch, Double — —A method of magnetization in which two closely approximated magnet poles are simultaneously drawn from one end of the bar to be magnetized to the other and back again, and this repeated a number of times.

Touch, Separate — —A method of magnetization in which two magnetizing poles are simultaneously applied to the bar to be magnetized and drawn over it in opposite directions. (See *Magnetization by Touch.*)

Touch, Single — —A method of magnetization in which a single magnetizing bar is drawn from one end to the other of the bar to be magnetized, and returned through the air for the next stroke. (See *Magnetization, Methods of.*)

Tourmaline.—A mineral consisting of natural silicates and borates of alumina, lime, iron, etc., possessing pyro-electric properties. (See *Electricity, Pyro.*)

Tower, Conning — — A shot-proof tower from which the commander of a turret ship directs the movements of a vessel during action.

Tower, Electric — — A high tower provided for the support of a number of electric arc lamps, employed in systems of general illumination.

Tower System of Electric Lighting. — The lighting of extended areas by means of arc lights placed on the tops of tall towers.

The tower system of electric illumination is only applicable to wide open spaces, since otherwise objectionable shadows are apt to be formed.

Towing Torpedo. — (See *Torpedo, Towing.*)

Traction, Magnetic — — The force with which a magnet holds on to or retains its armature, when once attached thereto.

Magnetic traction is to be distinguished from magnetic attraction, or the ability of a magnet pole to draw an armature or other magnets towards it from a distance.

Train Wire. — (See *Wire, Train.*)

Tramway, Electric — — A railway over which cars are driven by means of electricity.

An electric railroad.

The term tramway is sometimes applied to roads in cities, as distinguished from inter-urban roads.

Transformer. — An inverted Ruhmkorff induction coil employed in systems of distribution by means of alternating currents.

A transformer is sometimes called a converter. The word transformer is, however, the one most employed.

A transformer consists essentially of an induction coil, Fig. 556, in which the primary wire is long and thin, and consequently has many turns, as compared with the secondary wire, S, S, which is short, thick, and has few turns.

To prevent heating and loss of energy in conversion, the core of the transformer is thoroughly laminated; to lower the resistance of its magnetic circuit, the transformer is usually iron-clad.

In a system of electrical distribution by means of transformers, alternating currents, of small current strength and comparatively considerable

difference of potential, are sent over a line from a distant station, and passing into the primary wire of a number of converters, generally connected to the line in multiple arc, produce, by induction

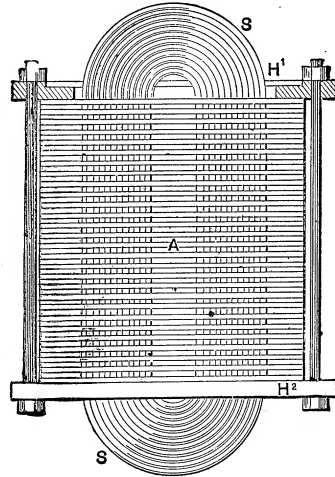

Fig. 556. Transformer.

currents of comparatively great strength and small difference of potential in the secondary wires.

Various electro-receptive devices are connected in multiple arc to circuits connected with the secondary wires.

This method of distribution greatly reduces the cost of the main conducting wires or leads in all cases where the distance is considerable, since considerable energy may be conveniently sent over a comparatively thin wire, with but a trifling loss, if the difference of potential is sufficiently great.

The general arrangement of the converters on the main line, and the connection of the secondary circuits with the electro-receptive devices in

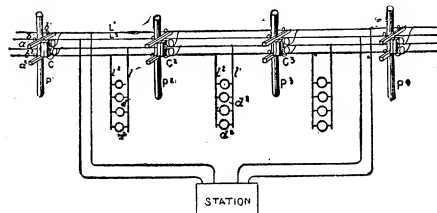

Fig. 557. Transformer Circuits.

such a system, are shown in Fig. 557. The transformers are supported on the line poles, as more

clearly shown in Fig. 558, in which the terminals of the primary and secondary of the converter are readily seen.

When the converter is properly constructed, the loss of conversion at full load is but small; that is to say, the number of watts in the secondary is very nearly equal to the number in the primary. A current of 10 ampères, at 2,000 volts, when passed into a converter the number of whose turns in the primary is twenty times the number in its secondary, will produce in its secondary a current whose strength is about twenty times as great, that is, nearly 200 ampères, but whose voltage is only about one-twentieth, or, 100; the watts in the two cases are nearly the same, or theoretically 20,000 watts.

The ratio between the windings of the primary and the secondary circuits is called the co-efficient of transformation.

In general, the shorter the wire on the secondary, and the smaller its number of turns, the greater is the reduction in the difference of potential, and the greater the current produced. The reduction is nearly proportionate to the ratio of the number of windings of the two coils.

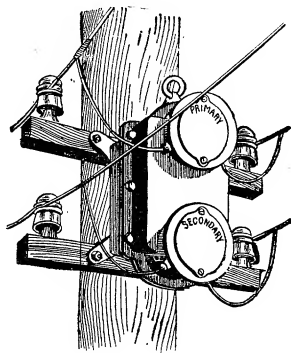

Fig. 558. Transformer Attached to Poles.

Transformer, Closed Iron Circuit — —A transformer the core of which forms a complete magnetic circuit.

These transformers are sometimes called iron-clad transformers.

Transformer, Commuting — —A term sometimes applied to a variety of motor generator in which neither the armature nor the field magnets revolve, the variations in the polarity of the magnetic circuit being obtained by means of special commutators.

Transformer, Constant-Current — —A transformer in which a current of a constant potential in the primary is converted into a current of constant strength in the secondary, despite changes in the load on the secondary.

Transformer, Core — —A transformer in which the primary and secondary wires are wrapped around the outside of a core consisting of a bundle of soft iron wires or plates.

A Ruhmkorff coil is a core transformer.

Transformer, Efficiency of — —The ratio between the whole energy supplied in any given time to the primary circuit of a transformer and that which appears in the form of electric current in the secondary circuit.

The energy applied to the primary circuit of a transformer is dissipated:

(1.) By eddy currents in the core of the transformer. (See *Currents, Eddy*.)

(2.) By hysteresis, or magnetic friction. (See *Hysteresis*.)

(3.) By heating of the primary circuit.

(4.) By heating of the secondary circuit.

When a transformer is overloaded, its efficiency decreases. There is a certain range of secondary resistance and current, within which a transformer is most advantageously operated.

Transformer Guard.—(See *Guard, Transformer, Lightning*.)

Transformer, Hedgehog — —A name applied to a particular form of open-iron circuit transformer. (See *Transformer*.)

The advantages claimed for the hedgehog transformer are that it can be made to give a higher all-day efficiency, since it insures a smaller loss from hysteresis in the iron. The efficiency for very small loads, or for no loads is greater than in the closed-circuit transformer.

Transformer, Leakage Current of — —A term sometimes used for the current which escapes from the primary through the dielectric of a transformer to the secondary circuit.

The term is a bad one, since the true leakage current would be the current which represents the leakage between the primary or secondary circuit and the ground.

Transformer Lightning Arrester.—(See *Arrester, Lightning, Transformer*.)

Transformer, Multiple — —Any form of transformer which is connected in multiple to the primary circuit.

A multiple or parallel transformer is self-regulating under variable loads, provided the electromotive force in the primary is maintained constant.

Transformer, Oil — —A transformer which is immersed in oil in order to insure a high insulation.

Transformer, Open-Iron Circuit — —A transformer the iron of which does not form a complete magnetic circuit, but is formed instead partly of iron and partly of air.

Transformer, Pilot — —A small transformer, placed at any desired portions of a line in order to determine the drop of potential.

The pilot transformer is used in connection with a lamp or other suitable indicating device. Its use is similar to the use of the pilot incandescent lamp.

Transformer, Rotary-Current — —A transformer operated by means of a rotary current. (See *Current, Rotating*.)

The rotary current transformer for a rotary current of three separate alternating currents combined, transforms all three currents together. There are three cores, connected at one set of ends and at the other to the circumference of an iron ring. Each core contains a primary and secondary wire.

Transformer, Rotary-Phase — —A rotary current transformer. (See *Transformer, Rotary-Current*.)

Transformer, Series — —Transformers which are connected in series with the primary circuit.

A series transformer is not as readily made self-regulating under variations in the load as a multiple transformer. If, however, its core is not saturated, and the electromotive force of its secondary is small, it can be made fairly self-regulating. Series transformers are used in the Jablochhoff system for feeding arc lamps in the shape of Jablochhoff candles.

Transformer, Shell — —A transformer

in which the primary and secondary coils are laid on each other, and the iron core is then wound through and over them so as to enclose all the copper of the primary and secondary circuits within the iron.

The iron shell surrounding the copper may consist of the thin plates of iron, built up so as to leave a rectangular space for the introduction of the primary and secondary.

Transformer, Step-Down — —A transformer in which a small current of comparatively great difference of potential is converted into a large current of comparatively small difference of potential.

An inverted Ruhmkorff induction coil.

Transformer, Step-Up — —A transformer in which a large current of comparatively small difference of potential is converted into a small current of comparatively great difference of potential.

The term step-up transformer is used in contradistinction to the step-down transformer.

The old form of Ruhmkorff coil is an example of a step-up transformer.

Transformer, Testing — —A transformer employed in any system of distribution for the purposes of testing for grounds, condition of line, drop of potential, etc.

Transformer, Welding — —A transformer suitable for changing a small electric current of comparatively high difference of potential, into the heavy currents of low difference of potential required for welding purposes.

Welding transformers have in general a very low resistance in their secondary coils, and almost invariably consist of a single turn or at the most of a few turns of very stout wire.

Transforming Currents.—(See *Current, Transforming a*.)

Transforming Down.—Transforming by means of a step-down transformer. (See *Transformer, Step-Down*.)

Transforming Station.—(See *Station, Transforming*.)

Transforming Up.—Transforming by means of a step-up transformer. (See *Transformer, Step-Up*.)

Transient Currents.—(See *Currents, Transient.*)

Transit, Magnetic Variation — —An apparatus for measuring the declination or variation of the magnetic needle at any place.

The variation transit generally consists of an altitude and azimuth instrument, the telescope of which is so arranged as to be readily converted into a microscope.

Transition Resistance.—(See *Resistance, Transition.*)

Translator, Double-Current — —A telegraphic translator or repeater designed to operate on double current transmission.

Translator, Single-Current — —A telegraphic translator or repeater designed to operate a single-current transmission.

Translator, Telegraphic — —A term sometimes applied to a telegraphic repeater. (See *Repeaters, Telegraphic.*)

Translating Device.—(See *Device, Translating.*)

Translating Devices, Multiple-Arc-Connected — —(See *Devices, Translating, Multiple-Arc-Connected.*)

Translating Devices, Multiple-Connected — —(See *Devices, Translating, Multiple-Connected.*)

Translating Devices, Multiple-Series-Connected — —(See *Devices, Translating, Multiple-Series-Connected.*)

Translating Devices, Series-Connected — —(See *Devices, Translating, Series-Connected.*)

Translating Devices, Series-Multiple-Connected — —(See *Devices, Translating, Series-Multiple-Connected.*)

Translucent-Disc Photometer. — (See *Photometer, Translucent-Disc.*)

Transmission, Double — —The simultaneous sending of two messages over a single wire in opposite directions. (See *Telegraphy, Duplex, Bridge Method of.*)

Transmission, Multiple — —The simultaneous sending of more than two messages over a single line or conductor.

Transmission of Energy.—(See *Energy, Electric, Transmission of.*)

Transmitter, Carbon, for Telephones — —A telephone transmitter consisting of a button of compressible carbon.

The sound waves impart to-and-fro movements to the transmitting diaphragm, and this to the carbon button, thus varying its resistance by pressure. This button is placed in circuit with the battery and induction coil. (See *Telephone.*)

Transmitter, Double-Current — —The transmitting instrument employed in systems of telegraphy, by means of which the direction of the currents on the line is alternately changed, according to whether the key rests on its front or on its back stop.

Double-current transmitters are used in connection with instruments, such as polarized relays, which respond to change in the direction of the current, rather than to changes in its intensity.

Transmitter, Electric — —A name applied to various electric apparatus employed in telegraphy or telephony to transmit or send the electric impulses over a line wire or conductor.

The sending instrument as distinguished from the receiving instrument.

In most telegraphic systems, the transmitting instrument consists of various forms of keys for interrupting or varying the current. In the telephone the transmitter consists of a diaphragm operated by the voice of the speaker. (See *Telephone.*)

Transmitter, Water-Jet Telephone — —A telephone transmitter consisting of a jet of water issuing vertically downwards from a small orifice.

The jet forms a part of the circuit of the receiving telephone. In order to reduce its resistance, the water is rendered acid by the addition of sulphuric acid, and a battery of high electromotive force is employed. Since the jet has a high resistance, a battery of high resistance can be used without inconvenience.

Transposing.—In a system of telephonic communication a device for avoiding the bad effects of induction by alternately crossing equal lengths of consecutive sections of the line. (See *Connection, Telephonic Cross.*)

Transverse Electromotive Force.—(See *Force, Electromotive, Transverse.*)

Treatment, Hydro-Carbon, of Carbons — — Exposing carbons, while electrically heated to incandescence, to the action of a carbonizing gas, vapor or liquid, for the purpose of rendering them more uniformly electrically conducting throughout. (See *Carbons, Flashing Process for.*)

Tree, Parallel, Circuit — — (See *Circuit, Parallel-Tree.*)

Trembling Bell.—(See *Bell, Trembling.*)

Trigonometrical.—Of or pertaining to trigonometry. (See *Trigonometry.*)

Trigonometrical Function.—(See *Function, Trigonometrical.*)

Trigonometrically.—In a trigonometrical manner.

Trigonometry.—That branch of mathematical science which treats of the methods of determining the values of the angles and sides of a triangle.

There are in every triangle three sides and three angles. If any three of these parts are given, except the three angles, the values of the remaining parts can be determined by means of

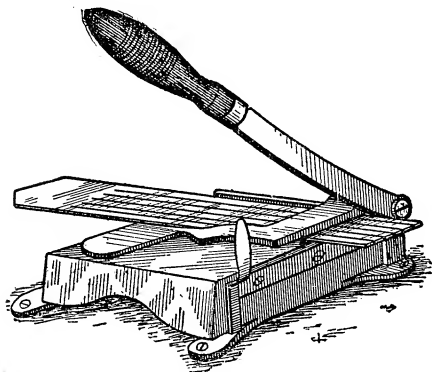

Fig. 559. *Dynamo Brush Trimmer.*

trigonometry, by what is called the solution of the triangle. (See *Function, Trigonometrical.*)

Trimmer.—An employée of an electric light company who renews the carbons in arc lamps.

Trimmer, Dynamo Brush — — A device for insuring rapid and accurate trimming of dynamo brushes.

The brush trimmer consists of a knife, placed as shown in Fig. 559 on a rigid support. The brushes are placed under a clamp, and against a straight edge, so that a single cut with the knife blade insures a clean and true cut.

Trimming.—A term sometimes applied to the act of placing the carbons in an electric arc lamp.

The phrase, carboning a lamp, would appear to be preferable to trimming a lamp.

Triple-Carbon Arc Lamp.—(See *Lamp, Arc, Triple-Carbon.*)

Tripod Roof Support.—(See *Support, Tripod Roof.*)

Trolley.—A rolling contact wheel that moves over the overhead lines provided for a line of electric railway cars, and carries off the current required to drive the motor car.

Trolley Crossing.—A device placed at the crossing of two trolley wires, by which the trolley wheel running on one wire may cross the other.

Such a device can also be made to hold the two wires together.

Trolley Crossing, Insulated — — A device used at the crossing of two trolley wires, which insulates the wires from each other, but which permits the trolley wheel of one line to cross the other trolley line.

Trolley Cross-Over.—(See *Cross-Over, Trolley.*)

Trolley, Double — — The traveling conductors, which move over the lines of wire in any system of electric railways that employs two overhead conductors.

In one form of double trolley a bar of wood carries two hangers, separated from each other, and furnished with diverging feet, with clips that embrace the two conducting wires. These wires serve also as the track for the two-wheeled trolley. The trolley consists of two plates connected to and insulated from each other under the conductors,

and carrying flanged wheels, extending in over the conductors.

Swinging from the axles of the poles are arms, which form a bail-like draft loop, with insulated material between their lower ends, and furnish means for connection with the car motor. In order to remove this trolley from the conducting wires, these arms are pressed together at points between two points of hangers, which allows them to pass between the inner ends of the wheel axles.

The trolley cannot be removed from the wires except at the end of the track, and it is therefore found in practice to be particularly useful in mines, where, from the nature of the galleries, the trolley wheel is very apt to become detached from the trolley wires.

Trolley, Drop — —The trolley wheel and rod for an electric car which drops away from the wire on slipping from the wire, and is reset upwards through proper elastic pressure.

Trolley Fork.—(See *Fork, Trolley*.)

Trolley Frog.—(See *Frog, Trolley*.)

Trolley Frog, Standard — —(See *Frog, Trolley, Standard*.)

Trolley Hanger.—(See *Hanger, Trolley*.)

Trolley Pole.—(See *Pole, Trolley*.)

Trolley Section.—(See *Section, Trolley*.)

Trolley, Single — —A traveling conductor or wheel which moves over a single conductor in a system of electric railways, and takes off the current for driving the electric motor, in connection with an earth or grounded return conductor.

Trolley Wheel.—(See *Wheel, Trolley*.)

Trolley, Wire — —(See *Wire, Trolley*.)

True Contact Force.—(See *Force, True Contact*.)

True Resistance. — (See *Resistance, True*.)

Trumpet, Electric — —An electromagnetic buzzer, the sound of which is strengthened by means of a resonator in the shape of a trumpet. (See *Buzzer, Electric, Resonator, Electric*.)

The electric trumpet is used to replace electric bells. It gives a louder and more penetrating sound than the electric bell.

Trunking Switch Board.—(See *Board, Switch, Trunking*.)

Tube, Crookes' — —A tube containing a high vacuum and adapted for showing any of the phenomena of the ultra-gaseous state of matter. (See *Matter, Radiant, or Ultra-Gaseous*.)

Tube, Insulating — —A tube of insulating material provided for covering a splice in an insulated conductor.

Tube, Mercury — —Vacuous glass tubes in which a flash of light is produced by the fall of a small quantity of mercury placed inside it.

The light is caused by the electricity produced by the friction of the mercury in falling against the sides of a spiral glass tube placed inside the vacuous tube.

Tube, Plücker — —A modification of a Geissler tube adapted for the study of the stratification of the light, and the peculiarities of the space adjoining the negative electrode. (See *Tubes, Geissler*.)

Tube, Spark — —A high vacuum tube, across which, when the vacuum is sufficiently high, the spark from an induction coil will not pass.

A spark tube, connected with incandescent lamps while undergoing exhaustion, acts as a simple gauge to determine the degree of exhaustion. When an induction coil discharge ceases either to pass, or to pass freely, the vacuum is considered as sufficient, according to circumstances.

Tube, Stratification — —An exhausted glass tube, the residual atmosphere of which displays alternate dark and light striæ, or stratifications, on the passage through it of an induction coil discharge. (See *Discharge, Luminous Effects of*.)

Tubes, Geissler — —Vacuum tubes of glass containing various gases, liquids or solids, provided with platinum electrodes, passed through and fused into the glass, designed to show the various luminous effects

of electric discharges through gases at comparatively low pressures.

Geissler tubes are made of a great variety of shapes, and often include tubes, spirals, spheres, etc., within other tubes. These enclosed tubes are made either of ordinary glass, or of uranium glass in order to obtain the effects of fluorescence.

The vacuum in Geissler tubes is by no means what might be called a high vacuum. Indeed, if the exhaustion of the tube be pushed too far, much of the brilliancy of the luminous effects is lost.

Some of the many forms of Geissler tubes are shown in Fig. 560.

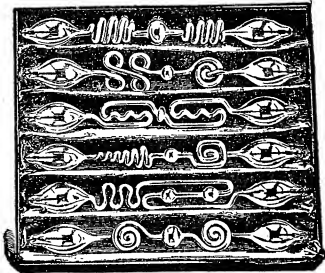

Fig. 560. Geissler Tubes.

Tubes of Force.—(See *Force, Tubes of*.)

Tubes of Induction.—(See *Induction, Tubes of*.)

Tubes, Vacuum — —Glass tubes, from which the air has been partially exhausted and through which electric discharges are passed for the production of luminous effects. (See *Tubes, Geissler*.)

Tubular Braid.—(See *Braid, Tubular*.)

Tumbling Box.—(See *Box, Tumbling*.)

Tuning-Fork or Reed Interrupter.—(See *Interrupter, Tuning-Fork. Interrupter, Reed*.)

Turn, Ampère — —A single turn or winding in a coil of wire through which one ampère passes.

An ampère-turn is sometimes called an ampère-winding. Magneto-motive force in a magnetic circuit is proportioned to the number of ampère-turns linked with it. The practical unit of magneto-motive force is $\frac{1}{4\pi} \times$ ampère turn = .0796 ampère turn. Therefore the magneto-motive

force, m. m. f., is found by multiplying the ampère turns by 4π or 12.57.

The number of ampères multiplied by the number of windings or turns of wire in a coil give the total number of ampère-turns in the coil.

In a coil of fixed dimensions the magnetizing force developed by a given number of ampère-turns remains the same as long as the product of the ampères and the current remains the same. That is to say, the same amount of magnetizing force can be obtained by the use of many windings and a small current, as in shunt dynamos, or by a few turns and a proportionally large current, as in series dynamos. (See *Machine, Dynamo-Electric*.)

Turns, Ampère, Primary — —The ampère-turns of the primary of an induction coil.

Turns, Ampère, Secondary — —The ampère-turns of the secondary of an induction coil.

Turns, Dead — —The number of revolutions a self-exciting dynamo makes before it excites itself.

Turns, Dead, of Armature Wire — —Those turns of the wire on the armature of a dynamo-electric machine which produce no useful electromotive force or resultant current, on the movement of the armature through the magnetic field of the machine.

The wire on the inside of a Gramme or ring armature is dead wire, but not dead turns.

Turns, Series, of Dynamo-Electric Machines — —The ampère-turns in the series circuit of a compound-wound dynamo-electric machine. (See *Machine, Dynamo-Electric, Compound-Wound*.)

Turns, Shunt, of Dynamo-Electric Machine — —The ampère-turns in the shunt circuit of a compound-wound dynamo-electric machine. (See *Machine, Dynamo-Electric, Compound-Wound*.)

Turn-Table, Electric — —A table, suitable for show windows, revolved around a vertical axis by means of an electric motor.

Twig.—A sub-branch. (See *Branch, Sub*.)

Twin Wire.—(See *Wire, Twin*.)

Twist in Leads.—(See *Leads, Armature, Twist in.*)

Twisted Bunched Cable.—(See *Cable, Bunched, Twisted.*)

Twisted-Pair Cable.—(See *Cable, Twisted-Pair.*)

Twisting Force.—(See *Force, Twisting.*)

Two-Fluid Voltaic Cell.—(See *Cell, Voltaic, Two-Fluid.*)

Two-Point Switch.—(See *Switch, Two-Point.*)

Two, Three, Four, etc., Conductor Cable
—(See *Cable, Two, Three, Four, etc., Conductor.*)

Two-Way Splice Box.—(See *Box, Splice, Two-Way.*)

Two-Way Switch.—(See *Switch, Two-Way.*)

Type-Printing Telegraph.—(See *Telegraphy, Printing.*)

Typewriter, Electric — —A typewriting machine, in which the keys are intended to make the contacts only of circuits of electro-magnets, by the attraction of the armatures of which the movements of the type levers required for the work of printing are effected.

Electric typewriters secure a uniformity of impression that is impossible to obtain with hand worked machines. They also greatly lessen the mechanical labor of writing. (See *Dynamograph.*)

U

U.—A contraction sometimes used for unit.

Ultra-Gaseous Matter.—(See *Matter, Radiant, or Ultra-Gaseous.*)

Underground Cable.—(See *Cable, Underground.*)

Underground Conductor.—(See *Conductor, Underground.*)

Undulating Currents.—(See *Current, Undulating.*)

Undulatory Currents.—(See *Currents, Undulatory.*)

Undulatory Discharge.—(See *Discharge, Undulatory.*)

Ungilding Bath.—(See *Bath, Ungilding.*)

Unidirectional Discharge.—(See *Discharge, Unidirectional.*)

Unidirectional Leak.—(See *Leak, Unidirectional.*)

Uniform Density of Field.—(See *Field, Uniform Density of.*)

Uniform Magnetic Field.—(See *Field, Magnetic, Uniform.*)

Uniform Magnetic Filament.—(See *Filament, Uniform Magnetic.*)

Uniform Potential.—(See *Potential, Uniform.*)

Uniformly Distributed Current.—(See *Current, Uniformly Distributed.*)

Unipolar Armature.—(See *Armature, Unipolar.*)

Unipolar-Electric Bath.—(See *Bath, Unipolar-Electric.*)

Unipolar Induction.—(See *Induction, Unipolar.*)

Unit Angle.—(See *Angle, Unit. Velocity, Angular.*)

Unit Angular Velocity.—(See *Velocity, Angular.*)

Unit, B. A. — —A term formerly applied to the British Association unit of resistance, or ohm. (See *Ohm.*)

Unit-Difference of Potential or Electromotive Force — —(See *Potential, Unit Difference of.*)

Unit, Magnetic, A — —A term sometimes used for a line of magnetic force, or the amount of magnetism induced in an area of one square centimetre at the centre of a coil having a diameter of 10 centimetres and carrying a current of 7.9578 ampères.

Unit, Natural, of Electricity — —(See *Electricity, Natural Unit of.*)

Unit of Acceleration.—(See *Acceleration, Unit of*.)

Unit of Activity.—(See *Activity, Unit of*.)

Unit of Current, Absolute — —(See *Current, Absolute Unit of*.)

Unit of Current, Jacobi's — —(See *Current, Jacobi's Unit of*.)

Unit of Electrical Supply.—(See *Supply, Unit of, Electrical*.)

Unit of Electromotive Force, Absolute — —(See *Force, Electromotive, Absolute Unit of*.)

Unit of Electrostatic Capacity.—(See *Capacity, Electrostatic, Unit of*.)

Unit of Heat.—(See *Heat Unit*.)

Unit of Inductance.—(See *Inductance, Unit of*.)

Unit of Mass.—(See *Mass, Unit of*.)

Unit of Photometric Intensity.—(See *Intensity, Photometric, Unit of*.)

Unit of Power.—(See *Power, Unit of*.)

Unit of Pressure, New — —The Barad. (See *Barad*.)

Unit of Resistance.—(See *Resistance, Unit of*.)

Unit of Resistance, Absolute — —(See *Resistance, Absolute Unit of*.)

Unit of Resistance, Jacobi's — —(See *Resistance, Unit of, Jacobi's*.)

Unit of Resistance, Matthiessen's — —(See *Resistance, Unit of, Matthiessen's*.)

Unit of Resistance, Varley's — —(See *Resistance, Unit of, Varley's*.)

Unit of Velocity, New — —(See *Velocity, New Unit of*.)

Unit Quantity of Electricity.—(See *Electricity, Unit Quantity of*.)

Unit-Strength of Current.—(See *Current, Unit Strength of*.)

Units, Absolute — —A system of units based on the centimetre for the unit of length, the gramme for the unit of mass, and the second for the unit of time.

These units are more frequently called the centimetre-gramme-second units.

Units, Centimetre-Gramme-Second — — A system of units in which the centimetre is adopted for the unit of length, the gramme for the unit of mass, and the second for unit of time.

This is the same as the absolute system of units.

Units, C. G. S. — —The centimetre-gramme-second units. (See *Units, Fundamental*.)

Units, Circular — —Units based upon the value of the area of a circle whose diameter is unity.

The advantages possessed by the circular units of cross-section arise from the fact that in these units the areas are equal to the squares of the diameter. No necessity exists, therefore, for multiplying by .7854.

Units, Circular (Cross-Sections), Table of — —

1 circular mil = .78540 square mil.
“ “ = .00064514 circular millimetre.
“ “ = .00050669 square millimetre.
1 square mil = 1.2732 circular mils.
“ “ = .00082141 circular millimetre.
1 circular millimetre = 1550.1 circular mils.
“ “ = 1217.4 square mils.
“ “ = .78540 square millimetre.
1 square millimetre = 1973.6 circular mils.
“ “ = 1.2732 circular millimetres.

If d, is the diameter of a circle, the area in other units is:

- If d, is in mils, the area in square millimetres..... = $d^2 \times .00050669$.
- d, in millimetres, area in square mils..... = $d^2 \times 1217.4$.
- d, in centimetres, area in square inches..... = $d^2 \times 1217.4$.
- d, in inches, area in square centimetres..... = $d^2 \times 5.0669$.

—(Hering.)

Units, Derived — — Various units obtained or derived from the fundamental units of Length, L., Mass, M., and Time, T.

The derived units and their dimensions are as follows:

Area, L².—The square centimetre.

Volume, L³.—The cubic centimetre.

Velocity, V.—Unit distance traversed in unit time, or

$$V = \frac{L}{T}. \quad (1)$$

Acceleration, A.—The rate of change which will produce a change of velocity of one centimetre per second.

$$A = \frac{V}{T}. \quad (2)$$

Substituting in equation (2) the value of V, in equation (1), we have

$$A = \frac{\frac{L}{T}}{T} = \frac{L}{T^2}. \quad (3)$$

Force, F.—The *dyne*, or the force required to act on unit mass in order to impart to it unit velocity.

$$F = M \times A. \quad (4)$$

Substituting the value of A, derived from equation (2), we have

$$F = M \times \frac{V}{T}.$$

Substituting the value of V, derived from equation (1), we have

$$F = \frac{M}{T} \times \frac{L}{T} = \frac{ML}{T^2}. \quad (5)$$

Work or Energy, W.—The *erg*, or the work done in overcoming unit force through unit distance.

$$W = F \times L = \frac{ML}{T^2} \times L = \frac{ML^2}{T^2}.$$

Power, P.—The unit rate of doing work.

$$P = \frac{W}{T} = \frac{\frac{ML^2}{T^2}}{T} = \frac{ML^2}{T^3}. \quad (6)$$

Units, Dimensions of — — The values given to the units of length, L; mass, M, and time, T. (See *Units, Derived*.)

Units, Electro-Magnetic — — A system of units derived from the C. G. S. units, em-

ployed in electro-magnetic measurements. (See *Units, Centimetre-Gramme-Second*.)

Units based on the attractions or repulsions between two unit magnetic poles at unit distance apart. (See *Units, Electrostatic*.)

Units, Electro-Magnetic, Dimensions of

$$\text{Current Strength} = \text{Intensity of Field} \times \text{Length} = \frac{\sqrt{ML}}{T}.$$

$$\text{Quantity} = \text{Current} \times \text{Time} = \sqrt{M \times L}.$$

Potential, Difference of Potential, Electromotive Force =

$$\frac{\text{Work}}{\text{Quantity}} = \frac{\sqrt{M \times L^3}}{T^2}.$$

$$\text{Resistance} = \frac{\text{Electromotive Force}}{\text{Current}} = \frac{L}{T}.$$

$$\text{Capacity} = \frac{\text{Quantity}}{\text{Potential}} = \frac{T^2}{L}.$$

Units, Electrostatic — — Units based on the attractions or repulsions of two unit charges of electricity at unit distance apart.

Two systems of electric units are derived from the C. G. S. system, viz., the *electrostatic* and *electro-magnetic*. These units are based respectively on the force exerted between two quantities of electricity and between two magnet poles.

The electrostatic units embrace the units of *quantity*, *potential* and *capacity*. No particular names have as yet been adopted for these units.

Unit of Quantity.—That quantity of electricity which will repel an equal quantity of the same kind of electricity placed at a distance of one centimetre from it with the force of one dyne.

Electrostatic potential, or power of doing electrostatic work, is measured in units of work, or ergs.

Unit Difference of Potential.—Such a difference of potential between two points as requires the expenditure of one *erg* of work to bring up a unit of positive electricity from one point to the other against the electric force.

Unit of Capacity.—Such a capacity of conductor as will take a charge of one unit of electricity when the potential is unity.

The ratio between the inductive capacity of a substance and that of air, measured under pre-

cisely similar conditions, is called the *specific inductive capacity*.

The specific inductive capacity is obtained by comparing the capacity of a condenser filled with the particular substance and the capacity of the same condenser when filled with air. The specific inductive capacity of air is taken as unity.

Units, Electrostatic, Dimensions of

$$\text{Quantity} = \sqrt{\text{Force} \times (\text{Distance})^2} = \sqrt{F \times L^2} =$$

$$\frac{M^{\frac{1}{2}} L^{\frac{3}{2}}}{T} = \frac{\sqrt{M \times L^3}}{T}$$

$$\text{Current} = \frac{\text{Quantity}}{\text{Time}} = \frac{M^{\frac{1}{2}} L^{\frac{3}{2}}}{T^2} = \frac{\sqrt{M \times L^3}}{T^2}$$

$$\text{Potential} = \frac{\text{Work}}{\text{Quantity}} = \frac{M^{\frac{1}{2}} L^{\frac{1}{2}}}{T} = \frac{\sqrt{M \times L}}{T}$$

$$\text{Resistance} = \frac{\text{Potential}}{\text{Current}} = L^{-1} T = \frac{T}{L}$$

$$\text{Capacity} = \frac{\text{Quantity}}{\text{Potential}} = L$$

Specific Inductive Capacity =

$$\frac{\text{One Quantity}}{\text{Another Quantity}} = \text{A Simple Ratio or Number.}$$

Electromotive Intensity =

$$\frac{\text{Force}}{\text{Quantity}} = M^{\frac{1}{2}} L^{\frac{1}{2}} T^{-\frac{1}{2}} = \frac{\sqrt{M \times L}}{T}$$

The fractional and negative exponents used above are merely convenient methods of expressing the extraction of roots and division respectively by the quantity represented by these exponents.

Units, Fundamental — — The units of length, time and mass, to which all other quantities can be referred.

The unit of length is now generally taken as the *centimetre*, the unit of time as the *second*, and the unit of mass as the *gramme*. These form a system of measurement known as the *centimetre-gramme-second* system, or the C. G. S. system, or absolute system. (See *Units, Derived*.)

The dimensions of the fundamental units are designated thus:

$$\begin{aligned} \text{Length} &= L. \\ \text{Mass} &= M. \\ \text{Time} &= T. \end{aligned}$$

Units, Heat — — Units based on the

quantity of heat required to raise a given weight or quantity of a substance, generally water, one degree.

The principal heat units are the English heat unit, the greater and smaller calorie and the joule. (See *Calorie, Joule*.)

The following table gives the values of some of the principal heat units :

1 gram, centigrade,	.001	kilogram centigrade..
1 pound Fahrenheit,	1,047.03	joules.
"	772.	foot-pounds.
"	106.731	kilogram metres.
"	.55556	pound centigrade.
"	.25200	kilogram centigrade.
"	.29084	watt-hours.
"	.0003953	metric horse-power.
"	.0003899	horse-power hours.
1 pound centigrade,	1,884.66	joules.
"	1,389.6	foot-pounds.
"	192.116	kilogram metres.
"	1.800	pound Fahrenheit.
"	.4536	kilogram centigrade.
"	.52352	watt-hour.
"	.0007115	metric horse-power hour.
"	.0007018	horse power hour.
1 kilogram centigrade,	4,154.95	joules.
"	3,063.5	foot-pounds.
"	423.54	kilogram metres.
"	3,9683	pound Fahrenheit.
"	2,2046	pound centigrade.
"	1.1542	watt-hour.
"	.001569	metric horse-power-hour.
"	.0015472	horse-power hour.

— *Hering*.

Units, Magnetic — — Units based on the force exerted between two magnet poles.

Unit strength of a magnetic pole is such a magnetic strength of pole that repels another magnetic pole of equal strength placed at unit distance with unit force, or with the force of one dyne.

Magnetic Potential.—Is the power of doing work possessed by a magnetic pole.

Magnetic potential is measured like electrostatic potential in units of work or in ergs.

Magnetic Potential, Unit Difference of.—Such a difference of magnetic potential between two points that requires the expenditure of one erg of work to bring a magnetic pole of unit strength from one to the other.

Unit Intensity of Magnetic Field.—Such an intensity of magnetic field as acts on a north or south-seeking pole of unit strength with the force of one dyne.

Units, Magnetic, Dimensions of — —
 Strength of Pole, or }
 Quantity of Magnetism }

$$= \sqrt{\text{Force} \times (\text{Distance})^2} = \sqrt{\frac{ML^3}{T}}$$

Magnetic Potential

$$= \frac{\text{Work}}{\text{Strength of Pole}} = \sqrt{\frac{M \times L}{T}}$$

$$\text{Intensity of Field} = \frac{\text{Force}}{\text{Strength of Pole}} = \frac{\sqrt{M}}{T \times \sqrt{L}}$$

Units, Practical — — Multiples or fractions of the absolute or centimetre-gramme-second units.

The practical units have been introduced because the absolute units are either too small or too large for actual use.

Electromotive Force.—The *Volt* = 100,000,000 C. G. S. or absolute units, that is, 10^8 absolute units of resistance. (See *Volt*.)

Resistance.—The *Ohm* = 1,000,000,000 absolute units of electromotive force, or 10^9 absolute units. (See *Ohm*.)

Current.—The *Ampère* = $\frac{1}{10}$ absolute unit of current. (See *Ampère*.)

Quantity.—The *Coulomb* = $\frac{1}{10}$ absolute unit of quantity, of the electro-magnetic system. (See *Coulomb*.)

Capacity.—The *Farad* = $\frac{1}{1,000,000,000}$ absolute unit of capacity, or 10^{-9} units of capacity. (See *Farad*. *Henry*. *Watt*. *Foules*.)

Units, Proposed New — — The following units and terms have recently been proposed by Oliver Heaviside.

Some of these have been generally adopted.

Conductance.—Capacity for conducting electricity.

Numerically, the ratio, in absolute measure, of the current strength to the total electromotive force in a circuit of uniform flow. A quantity with the nature of a slowness or reciprocal to a velocity. The practical unit is called the mho.

Conductivity.—Conductance per unit volume.

Elastance.—Capacity of a dielectric for opposing electric charge or displacement.

“Numerically, the ratio, in absolute measure, of the difference of potential in an electrostatic circuit to the total charge or displacement therein produced. The reciprocal of permittance and a quantity of the inverse nature of a length.”

“*Elasticity.*—Elastance per unit volume of dielectric.”

Impedance.—Capacity for opposing the variable flow of electricity.

“Numerically, in the absolute measure, the ratio of the total electromotive force to the current strength at any instant in a circuit of a variable flow. A quantity with the nature of a velocity and in any circuit always greater than the resistance.”

“*Inductance.*—Capacity for magnetic induction.”

“Numerically, in absolute measure, the number of unit lines of magnetic force linked with a circuit traversed by the unit current strength. Sometimes alluded to as the co-efficient of self-induction. A quantity of the nature of a length.”

“*Inductivity.*—Specific capacity for magnetic induction.

“The numerical ratio of the induction in a medium to the induction producing it.”

Permittance.—Electrostatic capacity. Capacity of a dielectric for assisting charge or displacement.

“Numerically, the ratio, in absolute measure, of the total charge or displacement in the electrostatic circuit, to the difference of potential producing it. A quantity with the nature of a length.”

“*Permittivity.*—The numerical ratio of the permittance of a dielectric to that of air.

“Also known as specific inductive capacity.”

“*Reluctance.*—Capacity for opposing magnetic induction.

“Numerically, the ratio, in absolute measure, of the magneto-motive force in a magnetic circuit to the total induction therein produced. A quantity with the nature of the reciprocal of a length. Sometimes described as magnetic resistance.”

Reluctancy or Reluctivity.—Reluctance per unit volume.

“Sometimes described as specific magnetic resistance. A numeric, the reciprocal of inductivity.”

“*Resistance.*—Capacity for opposing the steady flow of electricity.

“Numerically, in absolute measure, the ratio of the total electromotive force to the current strength in a circuit of uniform flow. A quantity with the nature of a velocity. The practical unit is called the ohm.”

“*Resistivity.*—Resistance per unit volume; sometimes alluded to as specific resistance.”

Universal Discharger.—(See *Discharger*, *Universal*.)

Upright Galvanometer.—(See *Galvanometer*, *Upright*.)

V

V.—A contraction sometimes used for volt.

V.—A contraction sometimes used for velocity.

V.—A contraction sometimes used for volume.

V. A.—A contraction sometimes used for voltaic alternative. (See *Alternatives, Voltaic.*)

Vacuum, Absolute — —A space from which all traces of residual gas have been removed.

A term sometimes loosely applied to a partial vacuum.

It is doubtful whether an absolute vacuum is attainable by any physical means.

Vacuum, High — —A space from which nearly all traces of air or residual gas have been removed.

Such a vacuum that the length of the mean free path of the molecules of the residual atmosphere is equal to or exceeds the dimensions of the containing vessel. (See *Layer, Crookes'.*)

Vacuum, Low — —Such a vacuum that the mean free path of the molecules of the residual gas is small as compared with the dimensions of the containing vessel. (See *Tubes, Geissler.*)

In a high vacuum groups of molecules can move across the containing vessel without meeting other groups of molecules. In a low vacuum such a group of molecules would be broken up by collision against other groups before reaching the other side of the vessel.

Vacuum, Partial — —A name sometimes applied to a low vacuum. (See *Vacuum, Low.*)

Vacuum, Torricellian — —The vacuum which exists above the surface of the mercury in a barometer tube or other vessel over thirty inches in vertical height.

The Torricellian vacuum is high only when the mercury has been carefully boiled and the tube or other vessel vigorously heated, so as to thor-

oughly drive out the moisture and adherent film of air.

Vacuum Tubes.—(See *Tubes, Vacuum.*)

Valency.—The worth or value of a chemical atom as regards its power of displacing other atoms in chemical compounds. (See *Atomicity.*)

The worth or valency of an atom of oxygen is twice as great as that of hydrogen, since one atom of oxygen is able to replace two hydrogen atoms in chemical combinations.

Valve, Electric — —An electrically controlled or operated valve.

In systems of electro-pneumatic signals, gaseous or liquid pressure controlled by electrically operated valves is employed to move signals, ring bells, control water and air valves, or to perform other similar work.

Vapor Globe of Incandescent Lamp.—(See *Globe, Vapor, of Incandescent Lamp.*)

Variable Inductance.—(See *Inductance, Variable.*)

Variable Period of Electric Current.—(See *Current, Variable Period of.*)

Variable Resistance.—(See *Resistance, Variable.*)

Variable Resistance, Automatic — —(See *Resistance, Variable, Automatic.*)

Variable Resistance, Non-Automatic — —(See *Resistance, Variable, Non-Automatic.*)

Variable State of Charge of Telegraph Line.—(See *State, Variable, of Charge of Telegraph Line.*)

Variation, Angle of — —The angle which measures the deviation of the magnetic needle to the east or west of the true geographic north.

The angle of declination of the magnetic needle. (See *Declination, Angle of.*)

Variation, Annual — —An approximately regular variation in the magnetic

needle which occurs at different seasons of the year.

Variation Chart or Map.—(See *Map or Chart, Isogonic.*)

Variation, Cyclical Magnetic—Secular magnetic variations occurring during great cycles of time. (See *Variation, Secular. Variation, Magnetic.*)

Variation, Diurnal —An approximately regular variation of the magnetic needle, which occurs at different hours of the day. (See *Declination.*)

Variation, Irregular —A variation of the magnetic needle which occurs at irregular intervals. (See *Declination.*)

Variation, Magnetic —Variations in the value of the magnetic declination, or inclination, that occur simultaneously over all parts of the earth.

The term is also applied to the magnetic declination itself.

These variations are:

(1.) Secular, or those occurring at great cycles of time.

(2.) Annual, or those occurring at different seasons of the year.

(3.) Diurnal, or those occurring at different hours of the day.

(4.) Irregular, or those accompanying magnetic storms. The first three are periodical; the last is irregular. (See *Declination, Angle of. Chart, Inclination.*)

Variation, Secular —A variation in the magnetic declination which occurs at great cycles or intervals of time. (See *Declination.*)

Varieties of Circuits.—(See *Circuits, Varieties of.*)

Variometer, Magnetic —An instrument for comparing the horizontal component of the earth's magnetism in different localities.

Varnish, Electric —A varnish formed of any good insulating material.

Shellac dissolved in alcohol, applied to a

thoroughly dried surface and afterwards hardened by baking, forms an excellent varnish.

Varnish, Stopping-Off —A varnish used in electro-plating to cover portions which are not to receive the metallic coating.

A good stopping-off varnish is made by mixing together 10 parts of resin, 6 parts of beeswax, 4 parts of sealing-wax and 3 parts of rouge, dissolved in turpentine. (See *Stopping-Off.*)

Vat, Depositing —The vat in which the process of electro-plating is carried on. (See *Plating, Electro.*)

The depositing vat contains the plating liquid, the metallic anode and the object to be plated.

Vegetation, Effects of Electricity on —Most vegetable fibres contract when an electric current is passed through them while on the living plant.

Some experiments appear to show that electric charges and currents hasten the germination and growth of certain plants. Other experiments seem to show that under certain circumstances electric currents retard plant growth. The direction of the currents is probably of main importance.

Velocimeter.—Any apparatus for measuring the speed of a machine.

Velocity, Angular —The velocity of a body moving in a circular path, measured, not as usual, by the length of its path divided by the time, but with reference to the angle it subtends and to the length of the radius.

Unit angle is that angle subtended by a part of the circumference equal to the length of the radius, or 57 degrees 17 minutes 44 seconds .8 nearly.—(*Daniell.*)

Unit angular velocity is the velocity under which a particle moving in a circular path, whose radius equals unity, would traverse unit angle in unit time.

Velocity, New Unit of —The kine. (See *Kine.*)

Velocity of Discharge.—(See *Discharge, Velocity of.*)

Velocity Ratio.—(See *Ratio, Velocity.*)

Ventilation of Armature.—(See *Armature, Ventilation of*.)

Vernier.—A device for the more accurate measurement of small differences of length than can be detected by the eye alone, by means of the direct reading of the position of a mark on a sliding scale.

The sliding scale is called the vernier. There are a variety of vernier scales in use.

Vertical Component of Earth's Magnetism.—(See *Component, Vertical, of Earth's Magnetism*.)

Vertical Electrostatic Voltmeter.—(See *Voltmeter, Vertical, Electrostatic*.)

Verticity, Poles of, Magnetic — —The earth's magnetic poles, as determined by means of the dipping needle.

The point of the north where the angle of dip is 90 degrees. (See *Map or Chart, Inclination*.)

Vibrating.—Moving to-and-fro.

Vibrating Bell.—(See *Bell, Vibrating*.)

Vibrating Contact.—(See *Contact, Vibrating*.)

Vibration.—A to-and-fro motion of the particles of an elastic medium. (See *Wave*.)

Vibration or Wave, Amplitude of — —

The ratio that exists in a wave between the degree of condensation and rarefaction of the medium in which the wave is propagated.

The amplitude of a wave is dependent on the amount of energy charged on the medium in which the vibration or wave is produced.

A vibration or wave is a to-and-fro motion produced in an elastic material or medium by the action of energy thereon. Sound, light and heat are subjectively effects produced by the action of vibrations or waves, which in the case of sound are set up in the air, and, in that of light and heat, in a highly tenuous medium called the luminiferous ether. Objectively they are the waves themselves.

As the amplitude of a sound wave increases, the loudness or intensity of the sound increases. As the amplitude of the ether wave increases, the brilliancy of the light or the intensity of the light or heat increases.

Let A C, Fig. 561 represent an elastic cord or string tightly stretched between A and C. If the string be plucked by the finger, it will move to-and-fro, as shown by the dotted lines. Each to-and-fro motion is called a *vibration*. The

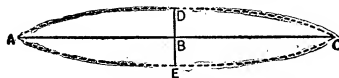

Fig. 561. *Amplitude of Wave.*

vertical distance B D, or B E, represents the *amplitude* of the vibration, and the sound produced is louder, the greater the amount of energy with which the string has been plucked, or, in other words, the greater the value of B D, or B E.

Vibrations assume various forms in solid or fluid media, but in all cases the amplitude will increase with the increase in the energy that causes the vibration.

Vibration Period.—(See *Period, Vibration*.)

Vibration, Period of — —The time occupied in executing one complete vibration or motion to-and-fro.

Vibration, Phase of — —The position of the particles in motion in a wave or vibration at any instant of time during the wave period, as compared with a zero line, or a line passing through their mean or middle position.

Vibrations, Isochronous — —Vibrations which perform their to-and-fro motions on either side of the position of rest in equal times.

The vibrations of a pendulum are practically isochronous, no matter what the amplitude of the swing may be, that is, whether the pendulum swings through a large arc or a small arc, provided this arc be not very great.

All vibrations that produce musical sounds may be regarded as isochronous; that is, in any case, the time required to complete a to-and-fro motion is the same at the beginning when the sound is loud, as at the end, when it is faint.

Vibrations, Sympathetic — —Vibrations set up in bodies by waves of exactly the same wave rate as those produced by the vibrating body.

The pitch or tone of the note produced by the body set into sympathetic vibration, is exactly the

same as the pitch or tone of the exciting waves or vibrations.

Hertz's experiments show that sympathetic vibrations are excited by electro-magnetic waves. (See *Electricity, Hertz's Theory of Electro-Magnetic Radiations or Waves.*)

Vibrations, Sympathetic, Electrical — —Vibrations set up in circuits, by the effect of pulses in neighboring circuits, that are of exactly the same mean length.

Vibrations, Synchronous — —Vibrations that are performed not only in the same time as one another, but which pass through the same portions of their to-and-fro movement at the same time.

Vibrator, Electro-Magnetic — —A lever, or arm, automatically moved to-and-fro by the alternate attractions of an electro-magnet and an opposing spring, or by the successive action of two electro-magnets.

In either case the movement of the lever is utilized to permit the action of first one and then the other device. Automatic or trembling bells are operated by means of an electro-magnetic vibrator.

Villari Critical Point.—A term proposed by Sir William Thomson for that strength of magnetic field at which the reversal of the effects of tension occurs.

Both magnetic susceptibility and permeability are affected by mechanical stress, vibration and changes of temperature. In a weak magnetic field the susceptibility of iron wire is increased by longitudinal tension, while in a strong field it may be decreased. The particular strength of field at which the reversal occurs is called the Villari critical point.

Viscosity, Magnetic — —That property of iron or other paramagnetic substance in virtue of which a certain time is required before a given magnetizing force can produce its effects. (See *Hysteresis, Viscous.*)

Viscous Hysteresis.—(See *Hysteresis, Viscous.*)

Vis-Viva.—The energy stored in a moving body, and therefore the measure of the amount of work that must be performed in order to bring a moving body to rest.

If M , is the mass and V , the velocity

$$\text{The Vis-Viva} = \frac{MV^2}{2}.$$

Vitreous Electricity.—(See *Electricity, Vitreous.*)

Vitrite.—An insulating substance.

Volatilization, Electric — —A term sometimes used instead of electric evaporation.—(See *Evaporation, Electric.*)

Volcanic Lightning.—(See *Lightning, Volcanic.*)

Volt.—The practical unit of electromotive force.

Such an electromotive force as is induced in a conductor which cuts lines of magnetic force at the rate of 100,000,000 per sec.

Such an electromotive force as would cause a current of one ampère to flow against the resistance of one ohm.

Such an electromotive force as would charge a condenser of the capacity of one farad with a quantity of electricity equal to one coulomb.

10^8 absolute electro-magnetic units of electromotive force.

Volt-Ammeter.—A wattmeter.

A variety of galvanometer capable of directly measuring the product of the difference of potential and the ampères. (See *Wattmeter.*)

Volt Ampère.—A watt. (See *Watt.*)

Volt-Coulomb.—The unit of electric work. The joule. (See *Joule.*)

Volt, Mega — —One million volts.

Volt, Micro — —The one-millionth of a volt.

Voltage.—This term is now very commonly used for either the electromotive force or difference of potential of any part of a circuit as determined by the reading of a voltmeter placed in that part of the circuit.

Voltage, Terminal — —The electromotive force expressed in volts of a dynamo or other electric source, as indicated by a voltmeter placed across its terminals.

The terminal voltage is greater than that on the leads or conductors at some distance from

the source and less than that generated by the source.

There is an exception to this general statement in the case of certain leads connected with an alternating dynamo-electric machine. (See *Effect, Ferranti.*)

Voltaic Arc.—(See *Arc, Voltaic.*)

Voltaic Battery.—(See *Battery, Voltaic.*)

Voltaic Battery Indicator.—(See *Indicator, Voltaic Battery.*)

Voltaic Battery Protector.—(See *Protector, Voltaic Battery.*)

Voltaic Cell.—(See *Cell, Voltaic.*)

Voltaic Cell, Bichromate — —(See *Cell, Voltaic, Bichromate.*)

Voltaic Cell, Bunsen's — —(See *Cell, Voltaic, Bunsen's.*)

Voltaic Cell, Callaud's — —(See *Cell, Voltaic, Callaud's.*)

Voltaic Cell, Capacity of Polarization of — —(See *Cell, Voltaic, Capacity of Polarization of.*)

Voltaic Cell, Closed-Circuit — —(See *Cell, Voltaic, Closed-Circuit.*)

Voltaic Cell, Contact Theory of — —(See *Cell, Voltaic, Contact Theory of.*)

Voltaic Cell, Creeping of — —(See *Cell, Voltaic, Creeping in.*)

Voltaic Cell, Daniell's — —(See *Cell, Voltaic, Daniell's.*)

Voltaic Cell, Double-Fluid — —(See *Cell, Voltaic, Double-Fluid.*)

Voltaic Cell, Dry — —(See *Cell, Voltaic, Dry.*)

Voltaic Cell, Gravity — —(See *Cell, Voltaic, Gravity.*)

Voltaic Cell, Grenët — —(See *Cell, Voltaic, Grenët.*)

Voltaic Cell, Grove — —(See *Cell, Voltaic, Grove.*)

Voltaic Cell, Leclanché — —(See *Cell, Voltaic, Leclanché.*)

Voltaic Cell, Local Action of — —(See *Action, Local, of Voltaic Cell.*)

Voltaic Cell, Meidinger — —(See *Cell, Voltaic, Meidinger.*)

Voltaic Cell, Negative Plate of — —(See *Plate, Negative, of Voltaic Cell.*)

Voltaic Cell, Open-Circuit — —(See *Cell, Voltaic, Open-Circuit.*)

Voltaic Cell, Poggendorff — —(See *Cell, Voltaic, Poggendorff.*)

Voltaic Cell, Polarization of — —(See *Cell, Voltaic, Polarization of.*)

Voltaic Cell, Positive Plate of — —(See *Plate, Positive, of Voltaic Cell.*)

Voltaic Cell, Siemens-Halske — —(See *Cell, Voltaic, Siemens-Halske.*)

Voltaic Cell, Simple — —(See *Cell, Voltaic, Simple.*)

Voltaic Cell, Single-Fluid — —(See *Cell, Voltaic, Single-Fluid.*)

Voltaic Cell, Smee — —(See *Cell, Voltaic, Smee.*)

Voltaic Cell, Standard — —(See *Cell, Voltaic, Standard.*)

Voltaic Cell, Standard, Clark's — —(See *Cell, Voltaic, Standard, Clark's.*)

Voltaic Cell, Standard, Clark's, Rayleigh's Form of — —(See *Cell, Voltaic, Standard, Rayleigh's Form of Clark's.*)

Voltaic Cell, Standard, Fleming's — —(See *Cell, Voltaic, Standard, Fleming's.*)

Voltaic Cell, Standard, Lodge's — —(See *Cell, Voltaic, Standard, Lodge's.*)

Voltaic Cell, Standard, Sir Wm. Thomson's — —(See *Cell, Voltaic, Standard, Sir William Thomson's.*)

Voltaic Cell, Standardizing — —(See *Cell, Voltaic, Standardizing a.*)

Voltaic Cell, Two-Fluid — —(See *Cell, Voltaic, Two-Fluid.*)

Voltaic Cell, Water — —(See *Cell, Voltaic, Water.*)

Voltaic Cell, Zinc-Carbon — —(See *Cell, Voltaic, Zinc-Carbon.*)

Voltaic Cell, Zinc-Copper — —(See *Cell, Voltaic, Zinc-Copper.*)

Voltaic Circle.—(See *Circle, Voltaic.*)

Voltaic Circuit.—(See *Circuit, Voltaic*.)

Voltaic Couple.—(See *Couple, Voltaic*.)

Voltaic Effect.—(See *Effect, Voltaic*.)

Voltaic Electricity.—(See *Electricity, Voltaic*.)

Voltaic Element.—(See *Element, Voltaic*.)

Voltaic or Current Induction.—(See *Induction, Voltaic*.)

Voltmeter.—An electrolytic cell employed for measuring the quantity of the electric current passing through it by the amount of chemical decomposition effected in a given time.

Various electrolytes are employed in voltmeters, such as aqueous solutions of sulphuric acid, copper sulphate, or other metallic salts.

In the sulphuric acid voltmeter shown in Fig. 562, the battery terminals are connected with platinum electrodes, immersed in water slightly acidulated with sulphuric acid, and placed inside glass tubes, also filled with acidulated water. On the passage of the current hydrogen appears at the kathode, and oxygen at the anode, in nearly the proportion of two volumes to one. (See *Ozone*.)

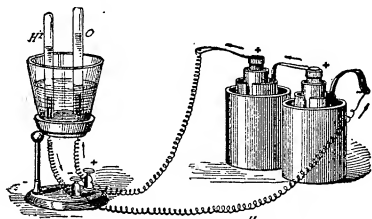
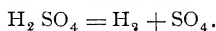

Fig. 562. A Sulphuric Acid Voltmeter.

In the case of water containing sulphuric acid (*hydrogen sulphate*) the decomposition would appear to be that of the sulphuric acid rather than that of the water. The reaction is as follows:



The hydrogen appears at the electro negative terminal or *kathode*. The SO_4 appears at the electro positive terminal or *anode*, but combines with one molecule of water, thus, $\text{SO}_4 + \text{H}_2\text{O} = \text{H}_2\text{SO}_4 + \text{O}$, gaseous oxygen being driven off at the anode.

Voltmeters are not as well suited as galvanometers for the measurement of electric currents, because a certain electromotive force must be reached before electrolysis is effected.

The voltmeter in reality measures the coulombs, and, therefore, is valuable as a current measurer only when the current is constant.

Coulomb-meter would, therefore, be the preferable term.

Then, again, time is required to produce the results, and considerable difficulty is experienced in maintaining the current strength constant, either on account of variations in the electromotive force of the source, or of variations in the resistance of the voltmeter.

Voltmeter, Copper——A voltmeter in which the quantity of the current passing is determined by the weight of copper deposited.

A current, the strength of which is constant, is passed through the voltmeter for a given time. The kathode, preferably of platinum, is thoroughly cleaned and dried with a current of heated air and accurately weighed before and after. The current strength is then deduced from the increase in weight and the time.

A galvanometer is kept in the circuit of the battery and voltmeter. If a Daniell battery is used, it should be kept on closed-circuit through a resistance for some time before use, in order to insure normal current.

It will be noticed that the indications of this voltmeter are based on the gain in weight of the kathode. The loss in weight of the anode is misleading, owing to secondary chemical action and disintegration.

Voltmeter, Gas ——A term sometimes used for volume voltmeter. (See *Voltmeter, Volume*.)

Voltmeter, Siemens' Differential —— A form of voltmeter employed by Sir William Siemens for determining the resistance of the platinum spiral used in his electric pyrometer. (See *Pyrometer, Siemens' Electric*.)

Two separate voltmeter tubes, provided with platinum electrodes and filled with dilute sulphuric acid, are provided with carefully graduated tubes to determine the volume of the decomposed gases. (See *Voltmeter, Volume*.)

A current from a battery is divided by a suitable commutator into two circuits connected respectively with the two voltmeter tubes. In one of these circuits a known resistance is placed, in the other the resistance to be measured, *i. e.*, the platinum coil used in the electric pyrometer.

Voltmeter, Silver — —A voltmeter in which the quantity of the current passing is determined by the weight of silver deposited.

A solution of silver nitrate is used as the electrolytic liquid. When the current to be measured is strong the strength of the silver nitrate solution is made stronger.

Voltmeter, Volume — —A voltmeter in which the quantity of the current passing is determined by the volume of the gases evolved.

In some forms of volume voltmeter in which dilute sulphuric acid is electrolyzed, both the hydrogen and the oxygen are measured, either separately or together.

In one form of volume voltmeter the hydrogen only is collected, and thus the error in volumetric determinations arising from the decrease in volume from the formation of ozone is avoided. The evolved oxygen is isolated from the hydrogen by placing a porous jar between the electrodes. The negative electrode, is formed of platinum fused in the tube, which, for ease of connection, is partially filled with mercury.

The graduated glass tube, in which the hydrogen is collected, is maintained at a nearly constant temperature by means of a water column. A thermometer is provided for corrections of volume as affected by temperature.

The voltmeter contains dilute sulphuric acid, about 30 per cent. of acid.

Voltmeter, Weight — —A voltmeter in which the quantity of the current passing is determined by the difference in the weight of the instrument after the circuit has passed for a given time.

A weight voltmeter consists essentially of platinum electrodes and some means for thoroughly drying the evolved gases. A vessel filled with pumice stone moistened with sulphuric acid, or a chloride of calcium tube, may be used for this purpose. The voltmeter is carefully weighed before and after the decomposition. The difference in weight gives the weight of the sulphuric acid decomposed.

Voltametric Law.—(See *Law, Voltametric.*)

Voltmeter.—An instrument used for meas-

uring difference of potential. (See *Galvanometer. Potential, Difference of. Volt.*)

A voltmeter may be constructed on the principle of a galvanometer, in which case it differs from an ammeter, or ampère meter, which measures the current, principally in that the resistance of its coils is greater, and that in an ampère meter the coils are placed in the circuit, while in a voltmeter they are placed as a shunt to the circuit.

The difference of potential is determined from the reading of a voltmeter, by the fact that according to Ohm's law, the product of the current and the resistance is equal to the electromotive force,

as $C = \frac{E}{R}$ from which we obtain $C \times R = E$.

In the ordinary operation of a voltmeter, the action of the current in passing through a coil of insulated wire is to produce a magnetic field, which causes the deflection of a magnetic needle. Since the resistance of the voltmeter is constant, the current passing, and hence the deflection of the needle, will vary with the value of E . The magnetic field produced by the current deflects the magnetic needle against the action of another field, which may be either the earth's field, or an artificial field produced by a permanent or an electro-magnet. Or, it may deflect it against the action of a spring, or against the force of gravity acting on a weight. There thus arise varieties of voltmeters, such as permanent-magnet voltmeters, spring voltmeters, and gravity voltmeters.

Or, the current produced by a given difference of potential may be used to heat a wire, and the value of the potential difference determined by the movement of a needle by the consequent expansion of a wire. Cardew's voltmeter operates on this principle. (See *Voltmeter, Cardew's.*)

Or, the potential difference to be measured may be utilized to charge a readily movable needle, and thus produce electrostatic attractions and repulsions.

This form of instrument is in reality a form of electrometer. (See *Electrometer, Quadrant. Attraction, Electrostatic.*)

Voltmeter, Cardew's — —A form of voltmeter in which the potential difference is measured by the amount of expansion caused by the heat of a current passing through a fixed resistance.

The current produced by the difference of potential to be measured is passed through a high

resistance wire of platinum silver, the expansion of which is caused to move a needle across a graduated arc. The wire is thin and therefore quickly acquires the temperature due to the current.

The Cardew voltmeter possesses an advantage of being independent of changes of temperature. It is also capable of being used to measure the potential difference of alternating currents.

Voltmeter, Closed-Circuit — —A voltmeter in which the points of the circuit, between which the potential difference is to be measured, are connected with a closed coil or circuit, and which gives indications by means of the current so produced in said circuit.

All galvanometer-voltmeters are of the closed-circuited type.

The Weston standard voltmeter shown in Fig. 563 is a closed-circuit voltmeter.

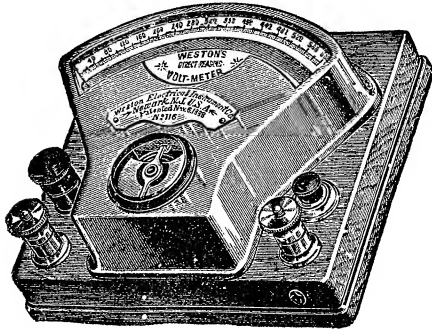

Fig. 563. Weston Standard Voltmeter.

Voltmeter, Electro-Magnetic — —A form of voltmeter in which the difference of potential is measured by the movement of a magnetic needle in the field of an electro-magnet. (See *Voltmeter*.)

Voltmeter, Gravity — —A form of voltmeter in which the potential difference is measured by the movement of a magnetic needle against the pull of a weight.

Sir William Thomson's balance instruments are used as gravity voltmeters. (See *Voltmeter*.)

Voltmeter, Magnetic-Vane — —A voltmeter in which the potential difference is measured by the repulsion exerted between a

fixed and a movable vane of soft iron placed within the field of the magnetizing coil.

A pointer, fixed to the moving vane, serves to measure the amount of the repulsion, and consequently the potential difference producing the magnetizing current. The moving vane moves under the magnetic repulsion against the action of a spring. Discs of copper for damping the movements of the movable vane, are placed before and behind it.

Voltmeter, Multi-Cellular Electrostatic — —An electrostatic voltmeter in which a series of fixed and movable plates are used instead of the single pair employed in the quadrant electrometer.

The movable pairs of plates are connected to a movable axis and placed vertically above one another. To the top of the axis is fixed a light aluminium needle or pointer, which moves over a graduated scale. A series of fixed plates, suitably supported and insulated from the ground, alternate with the needle plates.

Voltmeter, Open-Circuit — —A voltmeter in which the points of the circuit where potential difference is to be measured are connected with an open circuit and give indications by means of the charges so produced.

Electrometer-voltmeters are of the open-circuited type.

Voltmeter, Permanent Magnet — —A form of voltmeter in which the difference of potential is measured by the movement of a magnetic needle under the combined action of a coil and a permanent magnet, against the pull of a spring. (See *Voltmeter*.)

Voltmeter, Reducteur or Resistance for — —(See *Reducteur or Resistance for Voltmeter*.)

Voltmeter, Vertical Electrostatic — —A form of voltmeter the needle of which moves in a vertical instead of in a horizontal plane.

The construction of the vertical electrostatic voltmeter is, in general, similar to that of the quadrant electrometer. (See *Electrometer, Quadrant*.)

The fixed and movable sectors, the pointer and the graduated scale, however, are in vertical instead of horizontal planes.

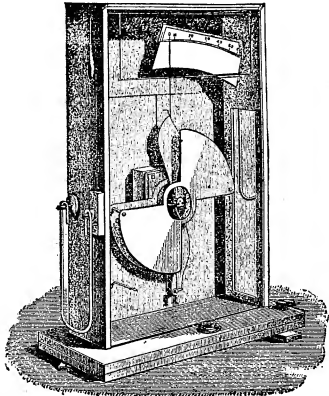

Fig. 564. Vertical Electrostatic Voltmeter.

The general arrangement of the vertical electrostatic voltmeter will be readily understood by an inspection of Fig. 564.

Volume Voltmeter.—(See *Voltmeter, Volume.*)

Vortex Atom.—(See *Atom, Vortex.*)

Vortex Cylinder.—(See *Cylinder, Vortex.*)

Vortex-Ring Field.—(See *Field, Vortex-Ring.*)

Vulcabeston.—An insulating substance composed of asbestos and rubber.

Vulcanite.—A variety of vulcanized rubber extensively used in the construction of electric apparatus.

Vulcanite is sometimes called ebonite from its black color. It is also sometimes called hard rubber.

Though an excellent insulator, vulcanite will lose its insulating properties by condensing a film of moisture on its surface. This can be best removed by the careful application of heat.

The surface is very liable to become covered by a film of sulphuric acid, due to the gradual oxidation of the sulphur. Mere friction will not remove this film, but it may be removed by washing with distilled water. A thick coating of varnish will obviate this last defect.

Vulcanized Fibre.—(See *Fibre, Vulcanized.*)

W

W.—A contraction sometimes used for watt.

W.—A contraction sometimes used for work.

W.—A contraction sometimes used for weight.

Wall Plug.—(See *Plug, Wall.*)

Wall Socket.—(See *Socket, Wall.*)

Ward.—A term proposed by James Thomson for a line and direction in a line.

Sir William Thomson thus defines the ward of magnetization: "The ward in which the magnetizing force urges a portion of the ideal northern magnetic matter or northern polarity."

Waring Anti-Induction Cable.—(See *Cable, Anti-Induction, Waring.*)

Waste Field.—(See *Field, Magnetic, Waste.*)

Watches, Demagnetization of — — Pro-

cesses for removing magnetism from watches.

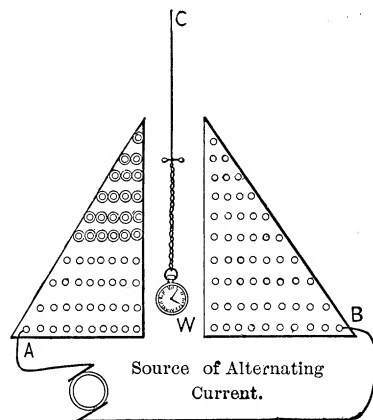

Fig. 565. Wright's Demagnetization Apparatus.

The demagnetization of watches can be readily effected by a method proposed by J. J. Wright.

The watch is held by its chain and slowly lowered to the bottom of a hollow conical coil of wire, and then slowly withdrawn from the coil.

The wire is wound on the coil, as shown in Fig. 565, in the shape of a cone, viz.: with a single turn at the top, and gradually increasing in number of turns towards the bottom. The conical coil is connected with a source of rapidly alternating currents.

As the watch is lowered into the coil, it gradually becomes more and more powerfully magnetized with alternately opposite polarities, thus completely removing any polarity it previously possessed. As it is now slowly raised from out the hollow cone, this magnetization becomes less and less, until, if removed from the conical coil while high above its apex, all sensible traces of magnetism will have disappeared.

Watchman's Electric Register.—(See *Register, Watchman's Electric.*)

Water Battery.—(See *Battery, Water.*)

Water-Dropping Accumulator.—(See *Accumulator, Water-Dropping.*)

Water, Electrolysis of — The decomposition of water by the passage through it of an electric current.

Water does not appear to conduct electricity when pure; it is therefore not quite certain that pure water can be electrolytically decomposed. The addition of a small quantity of sulphuric acid, or of a metallic salt, however, renders its electrolysis readily accomplished. (See *Voltameter.*)

In the opinion of most, it is the sulphuric acid that is decomposed rather than the water.

Water Horse-Power.—The Indian Government's term for horse-power developed by falling water.

The estimate is made by the following simple rule: 15 cubic feet of water falling per second through 1 foot equals 1 horse-power.

Water-Jet Telephone Transmitter.—(See *Transmitter, Water-Jet Telephone.*)

Water - Level Alarm.—(See *Alarm, Water or Liquid Level.*)

Water-Proof Wire.—(See *Wire, Water-Proof.*)

Water Pyrometer.—(See *Pyrometer, Siemens' Water.*)

Water Rheostat.—(See *Rheostat, Water.*)

Water Voltaic Cell.—(See *Cell, Voltaic, Water.*)

Watt.—The unit of electric power. The volt-ampère.

The power developed when 44.25 foot-pounds of work are done per minute, or 0.7375 foot-pounds per second.

The $\frac{1}{746}$ of a horse-power.

There are three equations which give the value of the watts, viz.:

(1.) $C E =$ The watts.

(2.) $C^2 R =$ The watts.

(3.) $\frac{E^2}{R} =$ The watts.

Where $C =$ the current in ampères; $E =$ the electromotive force in volts, and $R =$ the resistance in ohms. (See *Energy, Electric.*)

Watt Arc.—(See *Arc, Watt.*)

Watt Generator.—(See *Generator, Watt.*)

Watt-Hour.—A unit of electric work.

A term employed to indicate the expenditure of an electrical power of one watt, for an hour.

Watt-Hour, Kilo — — The Board of Trade unit of work equal to an output of one kilo-watt for one hour.

Watt, Kilo — — One thousand watts.

A unit of power sometimes used in stating the output of a dynamo.

A dynamo of 20 units, or a 20-unit machine, is one capable of giving an output of 20 kilo-watts.

Watt-Meter.—A galvanometer by means of which the simultaneous measurement of the difference of potential and the current passing is rendered possible.

The watt-meter consists of two coils of insulated wire, one coarse and the other fine, placed at right angles to each other as in the ohm-meter, only, instead of the currents acting on a suspended magnetic needle, they act on each other as in the electro-dynamometer.

Watt-Minute.—A unit of electric work.

An expenditure of electric power of one watt for one minute.

Watt-Second.—A unit of electric work.

An expenditure of electric power of one watt for one second.

Wave.—A disturbance in an elastic medium that is periodic both in space and time.

Wave, Electric — —An electric disturbance in an elastic medium that is periodic both in space and time. (See *Oscillations, Electric.*)

Waves, Amplitude of — —The amplitude of a vibration. (See *Vibration or Wave, Amplitude of.*)

Waves, Displacement — —Waves produced in the ether of dielectrics by means of electric displacement.

The electric stress applied to a dielectric to produce electric displacement soon strains it to its utmost and no further displacement can occur until the direction of the electric power is reversed. A rapidly intermittent current therefore can pass through a dielectric and thus produce a series of displacement waves.

Dielectrics, therefore, may be considered as pervious or transparent to rapidly intermittent or reversed periodic currents, but opaque or impervious to continuous currents. A condenser interpolated in a telephone circuit does not prevent telephonic communication, though it does effectually stop all continuous currents.

Waves, Electro-Magnetic — —Waves in the ether that are given off from a circuit through which an oscillating discharge is passing, or from a magnetic circuit undergoing variations in magnetic intensity.

Waves, Electro-Magnetic, Interference of — —Interference effects similar to those produced in the case of waves of light, observed in the case of electro-magnetic radiations, or waves, in which one system of waves, retarded a half wave length behind another system of equal wave length and amplitude, results in a complete loss of motion of the particles of the ether they tend to simultaneously affect.

In order that complete interference may take place, it is necessary

(1.) That the two waves, or system of waves, must meet in opposite phases. That is, that one be retarded back of the other one-half a wave length, or some odd number of half wave lengths.

(2.) That the waves simultaneously affect the

same particles of ether in which they are moving.

(3.) That the energy charged on the ether in the shape of waves of electro-magnetic radiation, must be equal in the case of each system of waves.

(4.) That the two systems of waves must have the same wave length.

These conditions, it will be seen, are exactly the same as in the case of the interference of light.

It will, of course, be readily understood that if electro-magnetic radiations can produce the effect of resonance, they must also necessarily produce interference effects.

Waves, Electro-Magnetic, Reflection of — —Reflection of electro-magnetic waves similar to the reflection of waves of light.

In his experiments on electro-magnetic radiations, Dr. Hertz shows that true reflection of electro-magnetic waves occurs from the surfaces of certain substances placed in the path of the waves.

In some experiments made in a large room, Dr. Hertz obtained undoubted indications of reflection of electro-magnetic waves from the walls of the room.

Waves of Condensation and Rarefaction. —The alternate spheres of condensed and rarefied air by means of which sound is transmitted. (See *Waves, Sound.*)

Waves, Sound — —Waves produced in air or other elastic media by the vibrations of a sonorous body. (See *Sound.*)

Way Line.—(See *Line, Way.*)

Weather Cross.—(See *Cross, Weather.*)

Weber.—A term formerly employed for the unit of electric current, and replaced by ampère. (See *Ampère.*)

The term weber was originally used to express a quantity of electricity equal to what is now called one coulomb, and a current designated by one weber per second. It was, however, used finally as a unit of current.

Weber.—A term proposed by Clausius and Siemens for a magnetic pole of unit strength, but not adopted.

This same term was also employed to designate the unit strength of current, now replaced by the term ampère.

Weber's Theory of Diamagnetism.—
(See *Diamagnetism, Weber's Theory of.*)

Weight, Atomic — —The relative weights of the atoms of elementary substances.

Since the atoms are assumed to be indivisible, they must unite or combine as wholes and not as parts. Although we cannot determine exactly the actual weights of the different elementary atoms, yet we can determine their relative weights by ascertaining the smallest proportions in which any two elements that combine atom for atom will unite with each other. Such numbers will represent the relative weights of the atoms as compared with hydrogen.

Weight Voltmeter.—(See *Voltmeter, Weight.*)

Weights and Measures, Metric System of — —A system of weights and measures adopted by almost all civilized nations except English-speaking, and by the scientific world generally.

For measures of length, the one ten-millionth part of the quadrant of a meridian of the earth is taken as the unit of length. This unit of length is called a metre, and various subdivisions and multiples of its length are made on the decimal system.

For a system of weights, the weight of one cubic centimetre of pure water at 39.2 degrees Fahr., the temperature of the maximum density of water, is taken as the unit of weight. This is called a *gramme*, and various multiples and subdivisions of this unit are made on the decimal system.

The following table of French measures and their corresponding English values are taken from Deschanel's "Elementary Treatise on Natural Philosophy":

Length.

1 millimetre = .03937 inch, or about $\frac{1}{25}$ inch.
1 centimetre = .3937 inch.
1 decimetre = 3.937 inches.
1 metre = 39.37 inches = 3.281 feet = 1.0936 yard.
1 kilometre = 1093.6 yards, or about $\frac{5}{8}$ mile.
Deschanel gives the length of the meter as equal to 39.370432 inches.

U. S. Coast Survey Bull. No. 9 of 1889, gives value of meter = 39.36980 inches. Therefore, 39.37 is probably as accurate as any other figure.

Area.

1 square millimetre = .00155 square inch.
1 square centimetre = .155 square inch.
1 square decimetre = 15.5 square inches.
1 square metre = 1550 square inches = 10.764 square feet = 1.196 square yards.

Volume.

1 cubic millimetre = .000061 cubic inch.
1 cubic centimetre = .061025 cubic inch.
1 decimetre = 61.0254 cubic inches.
1 cubic metre = 61025 cubic inches = 35.3156 cubic feet = 1.308 cubic yards.

The litre (used for liquids) is the same as the cubic decimetre, and is equal to 1.7617 pint, or .22021 gallon.

Mass and Weight.

1 milligramme = .01543 grain.
1 gramme = 15.432 grains.
1 kilogramme = 15432.3 grains = 2.205 pounds avoirdupois.

More accurately, the kilogramme is 2.20462125 pounds.

Miscellaneous.

1 gramme per square centimetre = 2.0481 pounds per square foot.

1 kilogramme per square centimetre = 14.223 pounds per square inch.

1 kilogrammetre = 7.2331 foot-pounds.

1 *force de cheval* = 75 kilogrammetres per second, or 542½ foot pounds per second, nearly, whereas 1 horse-power (English) = 550 foot-pounds per second.

Conversion of English into French measures;

Length.

1 inch = 2.54 centimetres, nearly.
1 foot = 30.48 centimetres, nearly.
1 yard = 91.44 centimetres, nearly.
1 statute mile = 160933 centimetres, nearly.
More accurately, 1 inch = 2.5399772 centimetres.

Area.

1 square inch = 6.45 square centimetres, nearly.
1 square foot = 929 square centimetres, nearly.
1 square yard = 8361 square centimetres, nearly.
1 square mile = 2.59 × 10¹⁰ square centimetres, nearly.

Volume.

1 cubic inch = 16.39 cubic centimetres, nearly.
1 cubic foot = 28316 cubic centimetres, nearly.

1 cubic yard = 764535 cubic centimetres, nearly.

1 gallon = 4541 cubic centimetres, nearly.

Mass.

1 grain = .0648 gramme, nearly.

1 ounce avoirdupois = 28.35 grammes, nearly.

1 pound avoirdupois = 453.6 grammes, nearly.

1 ton = 1.016×10^6 grammes, nearly.

More accurately, 1 pound avoirdupois = 453.59265 grammes.

Velocity.

1 mile per hour = 44.704 centimetres per second.

1 kilometre per hour = 27.7 centimetres per second.

Density.

1 pound per cubic foot = .016019 gramme per cubic centimetre.

62.4 pounds per cubic foot = 1 gramme per cubic centimetre.

Force (assuming $g = 981$).

Weight of 1 grain = 63.57 dynes, nearly.

" 1 ounce avoirdupois = 2.78×10^4 dynes, nearly.

" 1 pound avoirdupois = 4.45×10^5 dynes, nearly.

" 1 ton = 9.97×10^8 dynes, nearly.

" 1 gramme = 981 dynes, nearly.

" 1 kilogramme = 9.81×10^6 dynes, nearly.

Work (assuming $g = 981$).

1 foot-pound = 1.356×10^7 ergs, nearly.

1 kilogrammetre = 9.81×10^7 ergs, nearly.

Work in a second by one theoretical "horse-power" = 7.46×10^9 ergs, nearly.

Stress (assuming $g = 981$).

1 pound per square foot = 479 dynes per square centimetre, nearly.

1 pound per square inch = 6.9×10^4 dynes per centimetre, nearly.

1 kilogramme per square centimetre = 9.81×10^5 dynes per square centimetre, nearly.

760 millimetres of mercury at 0 degree C. = 1.014×10^6 dynes per square centimetre, nearly.

30 inches of mercury at 0 degree C. = 1.163×10^5 dynes per square centimetre, nearly.

Welding, Electric — — Effecting the welding union of metals by means of heat of electric origin.

In the process of Elihu Thomson, the metals

are heated to electric incandescence by currents obtained from transformers, and are subsequently pressed or hammered together.

Fig. 566, shows the Thomson apparatus for the direct system of electric welding. The dynamo is combined with the welding apparatus. The armature contains two separate windings; one of fine wire, in series with the field magnet coils, and another of very low resistance, being formed of a U-shaped bar of copper. No commutation is used, the alternating currents being well adapted for heating purposes. The terminals of the dynamo are, therefore directly connected to the clamps that hold the bar to the welder.

Fig. 567, shows the apparatus for the Thomson Indirect System of Electric Welding. This system is applicable to heavy work, and to cases where more than one welding machine is operated by the current from a single dynamo.

In this case a high tension current is converted

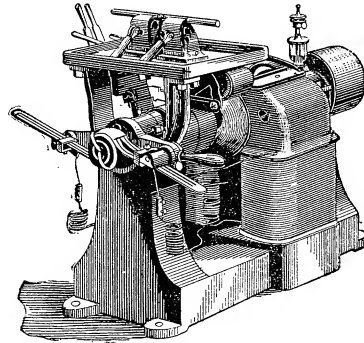

Fig. 566. The Thomson Direct Welder.

into the large welding current employed, by means of a suitably proportioned transformer.

The welding process is the same in either system, and consists essentially in leading the welding current into the pieces to be united through their points of junction when brought into firm end contact. As the current is led across the junction the temperature rises sufficiently to soften the metal, when the pieces are firmly pressed together by the motion of the clamps or holders.

In the process of Benardos and Olzewski, the heat of the voltaic arc is employed for a somewhat similar purpose, but by a different process.

In the Thomson system of electric welding alternating currents are employed. They are either supplied by an alternating current dynamo or by a transformer.

The process of welding is substantially as fol-

lows, viz.: the welding junctions are made slightly convex, so as to touch in but one part of their opposing faces. They are made to touch near their centres and the welding heat is first reached near their points of junction. Pressure is then applied by means of a screw, lever or hydraulic pressure until all the surfaces are at the welding temperature.

This operation requires in practice but a few seconds for small work, and at the most but a

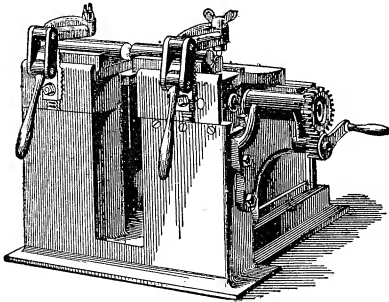

Fig. 567. The Thomson Indirect Welder.

few minutes for larger work. The heating is practically local, extending in most cases a distance equal to about the diameter of the weld.

For the purpose of controlling the electromotive force, and thus adapting the same welder to different classes of work, when a transformer is used, a second transformer provided with a movable core is placed in series with the first. A number of coils of insulated wire are placed in a segment of a split-ring laminated-core. These may be connected in series or in multiple by a switch. An iron armature placed within the split-ring encloses the annular core and acts as the low-resistance secondary. When this is placed so as to embrace the primary coils, the difference of potential will be different than if moved to one side or the other of the ring.

Welding Transformer.—(See *Transformer, Welding*.)

Wheatstone's Electric Balance.—(See *Balance, Wheatstone's Electric*.)

Wheatstone's Electric Bridge.—(See *Bridge, Wheatstone's Electric*.)

Wheel, Barlow's or Sturgeon's — — A wheel or disc of metal capable of rotation on a horizontal axis, that is set into rotation when placed between the poles of magnets and

traversed by a current of electricity from the centre to the circumference.

Wheel, Phonic — — A wheel maintained in synchronous rotation by means of timed electric impulses sent over a line, and employed in Delany's synchronous multiplex telegraphic system.

The phonic wheel was invented by La Cour, but was first put into successful operation in multiplex telegraphy by Delany in his system of synchronous multiplex telegraphy. (See *Telegraphy, Synchronous Multiplex, Delany's System*.) Delany obtains the exact synchronism of the phonic wheel by means of a series of correcting electric impulses, automatically sent over the line on the failure of the phonic wheel at either end of the line to exactly synchronize with that at the other end.

Wheel, Reaction, Electric — — A wheel driven by the reaction of a convective discharge. (See *Flyer, Electric*.)

Wheel, Trolley — — A metallic wheel connected with the trolley pole and moved over the trolley wire on the motion of the car over the tracks, for the purpose of taking the current from the trolley wire by means of rolling contact therewith.

Whirl, Electric — — A term employed to indicate the circular direction of the lines of magnetic force surrounding a conductor conveying an electric current. (See *Field, Electro-Magnetic*.)

This is more correctly called a magnetic whirl. (See *Whirl, Magnetic*.)

Whirl, Expanding Magnetic — — One of the magnetic whirls which are sent out from a conductor through which a current of gradually increasing strength is passing, or from a magnet whose magnetism is increasing.

These magnetic whirls, according to Hertz, move outward through free ether with the velocity of light.

Whirl, Magnetic — — The lines of magnetic force which surround the circuit of the conductor conveying an electric current.

Whistle, Steam, Automatic Electric — — A steam whistle, employed on foggy days in some systems of railway signals, when the

visual signals cannot be seen, in which the passage of the steam through the whistle is automatically obtained by the closing of an electric contact, or the passage of the locomotive over a certain part of the track.

White Heat.—(See *Heat, White.*)

White Hot.—(See *Hot, White.*)

Wimshurst Electrical Machine.—(See *Machine, Wimshurst Electrical.*)

Wind, Electric — —The convection stream of air particles produced at the extremities of points attached to the surface of charged, insulated conductors. (See *Convection, Electric. Flyer, Electric.*)

Windage of Dynamo.—A term proposed for the air gap between the armature and the pole pieces of a dynamo.

This term is not much used.

Winders, Telegraphic Paper — —Apparatus for winding or coiling the paper fillets used on telegraphic registers.

When moved by means of a spring they are generally styled automatic winders.

Winding, Ampère — —A single winding or turn through which one ampère passes.

Ampère-winding is used in the same signification as ampère-turn. (See *Turn, Ampère.*)

Winding, Bifilar — —A winding of a coil of wire in which, instead of winding the wire in one continuous length, it is doubled on itself and then wound.

This method is employed in resistance coils, so as to avoid the induction effects. (See *Coil, Resistance.*)

Winding, Compound, of Dynamo-Electric Machine — —A method of winding in which shunt and series coils are placed on the field magnets. (See *Machine, Dynamo-Electric, Compound-Wound.*)

Winding, Series — —A winding of a dynamo-electric machine in which a single set of magnetizing coils are placed on the field magnets, and connected in series with the armature and the external circuit. (See *Machine, Dynamo-Electric, Series-Wound.*)

Window-Tube Insulation.—(See *Insulator, Window-Tube.*)

Wipe Spark.—(See *Spark, Wipe.*)

Wiping Contact.—(See *Contact, Wiping.*)

Wire, Air-Line — —That portion of a circuit which is formed by air-strung wires, in contradistinction to the portion which passes through underground or submarine cables.

Wire, Binding, for Telegraph Lines — —The wire used for securing lines of wire conductors to the insulators.

The line wire rests against the insulators at as small an area of contact as possible, generally only a mere edge. In order to attach the wire to the insulator, and protect the wire from chafing, it is secured to the insulator by binding with wire.

Wire, Block — —A line or wire employed in a block system for railroads, connecting a block tower with the next tower on each side of it. (See *Railroads, Block System for.*)

Wire, Braided — —A conducting wire covered with a braiding, as distinguished from a wire that is merely wrapped with insulating material.

Cotton or silk is used for braiding. The covering is often coated by a layer of some insulating gum or varnish dissolved in a rapidly drying liquid. It is sometimes covered with melted paraffine.



Fig. 568. Braided Wire.

A copper wire covered with insulating material and then braided is shown in Fig. 568.

Wire, Calling — —A wire employed in a telegraphic or telephonic system, by means of which a subscriber communicates with the central office, or one central office communicates with another.

This wire is termed the *calling* wire in order to distinguish from the wire actually used for talking or telegraphing.

Wire, Conductibility and Sizes of — — For tables giving the resistance, size, weight per foot, etc., of wire according to some of the principal wire gauges see pages 254 and 256.

Wire, Copper, Hard-Drawn — —Copper wire that is drawn three or four times after annealing.

The drawing subsequent to annealing renders the wire hard and elastic, with but a trifling decrease in its conductivity. A hard-drawn wire, of course, possesses greater limits of elasticity than soft-drawn wire, and, therefore, in the case of air lines, permits of the use of a longer distance between adjacent poles.

Wire, Copper, Soft-Drawn — —Copper wire that is softened by annealing after drawing. (See *Wire, Copper, Hard-Drawn*.)

Wire, Dead, of Armature — —That part of the wire on the armature of a dynamo which produces no electromotive force or resultant current.

It is called dead because it does not move through the field of the machine.

Wire, Duplex — —An insulated conductor containing two separate parallel wires.

Wire, Earth-Grounded — —A wire one terminal of which is grounded or put to earth, so that the earth forms a part of the circuit in which the wire is placed.

Wire, Feeding — —A term sometimes applied to the wire or lead of a multiple circuit which feeds the main.

In a system of electric railroads the feeding wires feed the trolley wires.

Wire Finder.—(See *Finder, Wire*.)

Wire, Fuse — —A readily fusible wire employed in a safety catch to open the circuit when the current is excessive. (See *Catch, Safety*.)

Wire Gauge, Vernier — —(See *Gauge, Wire, Micrometer*.)

Wire, Grounded — —(See *Ground or Earth*.)

Wire, House — —In a system of incandescent electric lighting any conductor that is connected with a service conductor and leads to the meter in the house.

Wire, Insulated — —Wire covered with any insulating material.

Cotton and silk are generally employed for insulating purposes, either alone, or in connection with various gums, resins, or other materials, which are rendered plastic by heat, but which solidify on cooling. India rubber, caoutchouc, and various mixtures and compounds are also employed for the same purpose.

For most of the purposes of line wires, high insulating powers, combined with a low specific inductive capacity, are required in the insulating materials.

For overhead wires a waterproof covering is necessary. In the neighborhood of combustible materials, some fireproof covering is desirable.

Wire, Lead — —A lead fuse wire.

Wire, Line — —In telegraphy the wire that connects the different stations with one another.

In bell and annunciator circuits, the term line wire is sometimes applied to all circuits other than the main line.

In arc-light circuits the term line wire is applied to the entire metallic circuit, to which the lamps are connected in series.

Wire, Main — —The principal wire.

In any system of bell circuits, the main wire is the wire which runs from one pole of the battery to one of the springs of all the pushes, in distinction from the line wires, or the rest of the wires in the battery circuit.

Wire, Message — —A line or wire employed in a block system for railroads, extending along the road and used for local traffic or business. (See *Railroads, Block System for*.)

Wire, Negative — —A term sometimes applied to that wire of a parallel circuit which is connected to the negative pole of a source.

Wire, Neutral — —The middle wire of a three-wire system of electric distribution.

Wire, Omnibus — —An omnibus bar. (See *Bars, Omnibus*.)

A bus bar or wire. (See *Wires, Bus*.)

Wire, Paraffined — —Wire wrapped or braided with some textile material and afterwards coated with paraffine.

The term paraffined wire is sometimes limited to a wrapped wire that is afterwards paraffine coated.

Wire, Positive — —The wire or conductor connected to the positive pole or terminal of any electric source.

Wire, Potentiometer — —The wire of a potentiometer which has been calibrated in order to measure the drop of potential in any circuit. (See *Potentiometer*.)

Wire, Return — —The wire or conductor by means of which the current returns to the electric source after having passed through the electro-receptive devices. (See *Sources, Electric, Device, Electro-Receptive*.)

Wire, Shade Guard — —(See *Guard, Wire Shade*.)

Wire, Slide — —A wire of uniform diameter employed in Wheatstone's electric bridge for the proportionate arms of the bridge.

A sliding contact key moves over the slide wire and determines the length of the arms. Some forms of bridges have a double or a triple slide wire. (See *Bridge, Electric, Slide-Form of*.)

Wire, Span — —The wire employed in systems of electric railways for holding the trolley wire in place.

The span-wire is used when the poles are erected on both sides of the street or road-bed, and the trolley wire, suitably insulated from the span wire, is suspended therefrom.

Wire, Suspending, of Aërial Cable — —The wire from which an aërial cable is strung or suspended.

In case the aërial cable is unusually heavy the suspending wire is replaced by a wire rope. (See *Cable, Aërial*.)

Wire, Taped — —A conducting wire covered with an insulating material in the shape of tape.

A wire covered with an insulating material and subsequently taped is shown in Fig. 569.



Fig. 569. Taped Wire.

Wire, Tinned — —Copper wire covered with a coating of tin prior to its being insulated.

The coating of tin is for the purpose of insuring greater ease in soldering. It is also useful in case vulcanized rubber is used for the insulator, to prevent the sulphur from attacking the copper.

Wire, To — —To fix or place the conductors or mains for any electric circuit.

Wire, Train — —A line of wire employed in a block system for railroads, connected with the general dispatcher's office, and used for sending train orders only. (See *Railroads, Block System for*.)

Wire, Trolley — —The wire over which the trolley passes in a system of electric railways, and from which the current is taken to drive the motors on the cars.

A bare conductor or wire, supported overhead on suitable hangers and provided for transmitting current by the trolley to the motor connected with the car on the passage of the trolley wheel over its surface. (See *Wheel, Trolley*.)

Trolley wires, being necessarily bare, are carefully insulated at their points of attachment to all supports.

Wire, Trolley, Continuous — —A trolley wire or conductor employed in overhead dependent systems of electric railways. (See *Railroads, Electric, Dependent System of Motive Power for*.)

Wire, Trolley, Sectional or Divided — —A trolley wire or conductor for systems of electric railroads in which the wire is divided into a number of separate sections that are suitably connected with the generating dynamo by means of feeder wires. (See *Railroads, Electric, Dependent System of Motive Power for*.)

Wire, Trunk — —A main line or wire, extending between two distant stations, such as between two large cities, and provided solely for communication between them, not being tapped at intermediate points.

Wire, Twin — —A conductor, consisting of two separately insulated wires, bound together by an additional insulating covering.

Wire, Water-Proof — —A wire protected from the weather by a coating of any waterproof material.

Wire, Wrapped — —Wire that is insulated by placing strands of some insulating material, like cotton, parallel to its length, and then wrapping a number of strands around the wire.

The wrapped wire is afterwards either coated with paraffine or other insulator, or is used without such coating.

Wires, Bus — —A term sometimes used for omnibus bars or wires.

The wires which receive the full current generated by the electric source, and carry it to the feeders.

The bus-wires collect the current from all the sources, hence the name.

Wires, Breaking-Weight of — —The weight required to be hung at the end of a wire in order to break it.

Ordinary copper wire will break at about 17 tons to the square inch of area of cross section. Common wrought iron breaks at 25 tons to the square inch. These figures are to be regarded as approximate only, since almost inappreciable differences in the physical condition of metals, as well as slight variations in their chemical composition, often produce marked differences in their breaking weights.

Wires, Cross — —(See *Cross, Electric*.)

Wires, Crossing — —A device employed in telegraphic circuits whereby a faulty conductor is cut out of the circuit of a telegraph line by crossing over to a neighboring, less used, line.

To cut out a faulty section of wire in any circuit, such as C D, in the circuit A B C D E, Fig. 570, a cross-connection is made to a line X Y, running near it, and which may be temporarily thrown out of use. By this means the interruption of an important circuit may be repaired.

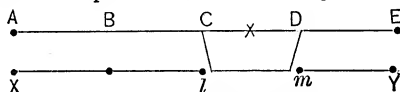

Fig. 570. Crossing Wires.

Wires, Dead — —Disused and abandoned electric wires.

The term *dead* is often applied to a wire through which no current is passing. The term, however, is more properly applied to a wire formerly employed, but subsequently abandoned.

Dead wires in the neighborhood of active wires are a constant menace to life and property, and should invariably be carefully removed.

It is often a matter of considerable importance to be able to determine whether or not a current is passing through a wire. When the wire is not enclosed in a moulding, or fastened against a wall, this can readily be ascertained by bringing a small compass needle near the wire, when it will tend to set itself across the wire.

The term dead wire, as will be seen, is used in two distinct senses.

Wires, Leading-In — —The wires or conductors which lead the current through (into and out of) an electric lamp.

The term leading-in wires is generally applied to incandescent electric lamps, Geissler or Crookes tubes, and to various other apparatus.

Wires, Leading-Up — —Wires employed for raising an aerial cable to the cable hangers.

Wires, Omnibus — —A term sometimes used for bus wires. (See *Wires, Bus*.)

Wires or Conductors, Continuous — — Wires or conductors free from joints.

Wires or conductors without soldered or twisted joints or without any joints whatsoever.

Wires, the entire lengths of which have been taken from the hitherto uncut coil of wire from the draw plate.

Strictly speaking, any metallic circuit consists of a continuous wire, whether in one piece or in several sections or pieces. The preferable term would appear to be unjointed wires or conductors.

Wires, Phantom — —A term applied to the additional circuits or wires obtained in any single wire or conductor by the use of some multiplex telegraphic system. (See *Telegraphy, Multiplex, Telegraphy, Synchronous-Multiplex, Delany's System*.)

Wires, Pilot — —In a system of incandescent lighting, where a comparatively low potential is employed on the mains, thin wires leading directly from the generating station to different parts of the mains, in order to determine the differences of potential at such points.

Pilot wires indicate on a voltmeter the difference of potential at the various points. The pilot wires extend to the various seats of supply, and so give instant warning of any change in the value of the potential.

Wires, Pressure — — In a system of incandescent electric lighting, wires or conductors, series-connected with the junction boxes, and employed in connection with suitable voltmeters, to indicate the pressure at the junction boxes.

The pressure wires are sometimes called the pilot wires.

Wires, Tap — — The wires or conductors used to carry the current from the feeders or mains at the pole to a near point on the trolley wire.

Wiring.—Collectively the wires or conducting circuits used in any system of electric distribution.

Wiring.—Placing or establishing the wires or conductors for any electric circuit.

Wiring, Case — — Placing or establishing electric conductors or wires that are held in place on the walls or ceiling of a room, by means of continuous cleats.

Wiring, Cleat — — Placing or establishing electric conductors or wires that are held in place on the walls or ceiling of a room by means of suitably shaped insulating cleats.

Wiring, Inside — — The conductors that, in a system of incandescent electric lighting, lead to the interior of the house or area to be lighted.

Wiring, Moulding — — Electric conductors or wires that are held in place on the walls or ceiling of a room by means of suitably shaped mouldings.

Work.—The product of the force by the distance through which the force acts.

A force whose intensity is equal to one pound acting through the distance of one foot, does an amount of work equal to one foot-pound.

Work is to be distinguished from the more general term energy.

Work, Electric — — The joule. (See *Joule*.)

The product of the volts by the coulombs.

1 joule = 10,000,000 ergs, or .73732 foot-pounds.

“ = 1 volt-coulomb.

“ = 1 watt for 1 second.

Work, Electric, Unit of — — The volt-coulomb or joule. (See *Volt-Coulomb. Joule*.)

Work, Unit of — — The erg.

The amount of work done when a force of one dyne acts through the distance of one centimetre. (See *Erg*.)

Raising one gramme against gravity, through the distance of one centimetre, requires an amount of work equal to 980 ergs.

Work, Units of — — Various units employed for the measurement of work.

The following table of Units of Work is taken from Hering’s work on Dynamo-Electric Machines :

WORK.

1 erg	= 1 dyne-centimetre.
1 “	= .0000001 joule.
1 gramme-centimetre ..	= 981.00 ergs.
1 “ ..	= .00001 kilogr.-metre.
1 foot-grain.....	= 1937.5 ergs.
1 joule, or 1 volt-coulomb, or 1 watt during every second or 1 volt-ampère during every second	= { 10,000,000 ergs, .737324 foot-pound, .101937 kilogram-metre, .0013592 metric horse-power for one second.
1 volt ampère during every second.....	= .0013406 horse-power for one second.
“	= .0009551 pound-Fah., heat unit.
“	= .0005306 pound-Centig., heat unit.
“	= .0002407 kilogr.-Centig., heat unit.
“	= .0002778 watt-hour.
1 foot-pound.....	= 13562600 ergs.
“	= 1.35626 joules.
“	= .13825 kilogr. metre.
“	= .0018434 metric horse-power for one second.
“	= .00181818 horse-power for one second.

1 foot pound..... = .0012953 pound-Fah., heat unit.
 " = .0007196 pound-Centig., heat unit.
 " = .0003264 kilogr.-Centig., heat unit.
 " = .0003767 watt-hour.
 1 kilogram-metre..... = 9810000 ergs.
 " = 9.81000 joules.
 " = 7.23314 foot-pounds.
 " = .01333 metric horse-power for one second.
 " = .013151 horse power for one second.
 " = .009369 pound-Fah., heat unit.
 " = .005205 pound-Centig., heat unit.
 " = .002361 kilogr.-Centig., heat unit.
 " = .002725 watt-hour.
 1 watt-hour = 3600 joules.
 " = 2654.4 foot-pounds.
 " = 366.97 kilogram-metres.
 " = 3.4383 pound-Fah., heat units.
 " = 1.9102 pound-Centig., heat units.
 " = .8664 kilogr.-Centig., heat units.
 " = .0013592 metric horse power hour.
 " = .0013406 horse-power-hour.
 1 metric h.-p.-hour = 2648700 joules.
 " = 1952940 foot-pounds.
 " = 270000 kilogram-metres.
 " = 2529.7 pound-Fah., heat units.
 " = 1405.4 pound-Centig., heat units.
 " = 637.5 kilogr.-Centig., heat units.
 " = 735.75 watt-hours.
 " = .98634 horse-power-hour.
 1 horse-power-hour.... = 2685400 joules.
 " = 1980000 foot-pounds.
 " = 273740 kilogram-metres.

1 horse-power-hour... = 2564.8 pound-Fah., heat units.
 " = 1424.9 pound-Centig., heat units.
 " = 646.31 kilogr.-Centig., heat units.
 " = 745.941 watt-hours.
 " = 1.01385 metric horse-power-hour.

HEAT.

1 gram-Centig..... = .001 kilogram Centigrade.
 1 pound-Fahr..... = 1047.03 joules.
 " = 772 foot-pounds.
 " = 106.731 kilogram-metres.
 " = .55556 pound-Centigrade.
 " = .25200 kilogram-Centigrade
 " = .29084 watt-hour.
 " = .0003953 metric horse-power-hour.
 " = .0003899 horse-power hour.
 1 pound-Centig..... = 1884.66 joules.
 " = 1389.6 foot-pounds.
 " = 192.116 kilogram-metres.
 " = 1.8000 pound-Fahrenheit.
 " = .4536 kilogram-Centigrade.
 " = .52352 watt-hours.
 " = .0007115 metric horse-power-hour.
 " = .0007018 horse-power-hour.
 1 kilogram-Centig..... = 4154.95 joules.
 " = 3063.5 foot-pounds.
 " = 423.54 kilogram-metres.
 " = 3.9683 pound-Fahrenheit.
 " = 2.2046 pound-Centigrade.
 " = 1.1542 watt hours.
 " = .001569 metric horse-power-hour
 " = .0015472 horse-power-hour.

Working, Direct — —The transmis-

sion of signals over a telegraph line without the use of relays or repeaters.

Working, Multiple, of a Dynamo-Electric Machine — —A term sometimes used for the parallel working of dynamo-electric machines. (See *Working, Parallel, of Dynamo-Electric Machines.*)

Working, Parallel, of Dynamo-Electric Machines — —The operation of working several dynamo-electric machines as a single source, by connecting them with one another in parallel or multiple arc.

The effect of parallel working is to reduce the internal resistance of the dynamo.

If a current be required in a circuit at an electromotive force equal only to that of a single machine, and the requirements of the circuit are equal to the output of more than a single dynamo, a number of dynamos must then be coupled in multiple.

Working, Reverse-Current — — —A term sometimes used in telegraphy for a method of working by means of a double current in place of a single current.

The double-current system of working was devised by Varley to permit Morse characters to be sent rapidly through underground conductors. In order to avoid the retardation due to induction, the current was reversed between each signal. This reversion in the conductor hastened the discharge of the conductor.

Working, Series, of Dynamo-Electric Machines — —Such a coupling of several dynamo-electric machines as will deliver the current supplied by them in series.

As in all series connections of sources, there results an electromotive force equal to the sum of the electromotive forces of the different dynamos.

Worming, Cable — —A central core of hemp or jute around which are wrapped the several separate conductors of a cable containing more than a single separate conductor.

Wood's Button Repeater.—(See *Repeaters, Telegraphic.*)

Wrapped Wire.—(See *Wire, Wrapped.*)

Writing, Electrolytic — —Imprinting written characters on cloths, or other textile fabrics, by the electrolytic decomposition of a dyeing substance with which they are impregnated.

The cloths, etc., to be written on, are impregnated with an aniline salt, and placed on an insulated metallic plate next to the salt, which is connected to one pole of an electric source. The other pole is connected to a carbon electrode, which is used as the writing stylus or pencil. By suitably connecting the terminals the writing is obtained in color on a white ground, or in white on a colored ground. (See *Dyeing, Electric.*)

Writing Telegraphy.—(See *Telegraphy, Writing.*)

Y

Y-Shaped Sparks. — (See *Spark, Y-Shaped.*)

Yale-Lock-Switch Burglar Alarm.—(See *Alarm, Yale-Lock-Switch Burglar.*)

Yoke, Multiple-Brush — —A term sometimes applied to multiple brush rocker of a dynamo or motor. (See *Rocker, Multiple-Pair Brush.*)

Yoke, Multiple-Pair Brush — —A device for holding a number of pairs of brushes of a dynamo-electric machine in such

a manner that they can be readily moved or rotated on the commutator cylinder.

The brushes are placed side by side on the commutator cylinder. In such cases the several pairs of brushes are so arranged that they can be thrown off or out of contact with the commutator cylinder while cleaning the cylinder, without stopping the machine.

Yoke, Single-Brush — —A term sometimes used for single-brush rocker. (See *Rocker, Single-Brush.*)

Yoke, Single-Pair — — A single-brush rocker. (See *Rocker, Single-Brush*.)

Yoke, Single-Pair Brush — — A device for holding a single pair of collecting brushes of a dynamo-electric machine in such a way

that they can be readily moved or rotated on the commutator cylinder.

Yoked-Horseshoe Electro-Magnet.—(See *Magnet, Electro, Yoked-Horseshoe*.)

Z

Z.—A symbol sometimes used in electro-therapeutics for contraction.

The use of Z, is for the purpose of avoiding the letter C, which has already been used for current or ampère in Ohm's law. Increasing strengths of contraction are represented by Z', Z'', Z'''.

Z.—A symbol for electro-chemical equivalent.

Zero, False — — A zero taken midway between any two equal and opposite deflections of a measuring instrument.

Zero, Inferred — — A zero deduced or inferred from the deflection produced by a charge that is to be measured by comparison with the value of the deflection by means of a known charge in an electrical measuring instrument.

An inferred zero is usually completely off the scale, hence its name. It does not actually exist.

Zero Methods.—(See *Method, Null or Zero*.)

Zero Potential.—(See *Potential, Zero*.)

Zero, Shifting — — A zero that changes or shifts in position; a polar zero in a measuring instrument.

Zigzag Electro-Magnet.—(See *Magnet, Electro, Zigzag*.)

Zigzag Electromotive Force.—(See *Force, Electromotive, Zigzag*.)

Zigzag Lightning.—(See *Lightning, Zigzag*.)

Zinc, Amalgamation of — — The covering or amalgamation of zinc with a layer of mercury.

To amalgamate a plate of zinc, its surface is first thoroughly cleaned by immersing the plate in dilute sulphuric acid of about 1 part of acid to

10 or 12 parts of water. A few drops of mercury are then rubbed over its surface, thus coating it with a bright metallic film of zinc amalgam. Care must be taken not to use too much mercury, since the zinc plate would thus be rendered brittle.

Zinc-Carbon Voltaic Cell.—(See *Cell, Voltaic, Zinc-Carbon*.)

Zinc-Copper Voltaic Cell.—(See *Cell, Voltaic, Zinc-Copper*.)

Zinc, Crow-Foot — — A crow-foot-shaped zinc used in the gravity voltaic cell. (See *Cell, Voltaic, Gravity*.)

The term "crow-foot" refers to the shape of the claws. It is hardly a happy term.

Zinc-Lead Voltaic Cell.—(See *Cell, Voltaic, Zinc-Lead*.)

Zinc Sender.—(See *Sender, Zinc*.)

Zincode of Voltaic Cell.—A term formerly employed to indicate the zinc terminal or electrode of a voltaic cell.

The negative electrode or kathode are preferable terms.

Zone, Anelectrotonic — — A name sometimes given to the polar zone. (See *Zone, Polar*.)

Zone, Kathero-tonic — — A name sometimes given to the peripolar zone. (See *Zone, Peripolar*.)

Zone, Peripolar — — A term proposed by De Watteville for the zone or region surrounding the polar zone on the body of a patient undergoing electro-therapeutic treatment.

Zone, Polar — — A term proposed by De Watteville for the zone or region surrounding the therapeutic electrode applied to the human body for electric treatment.

APPENDIX.

References to Words, Terms and Phrases which appear in the Appendix are preceded by the words "See Appendix"; all other references apply to the main portion of the Dictionary.

A

A.—A symbol proposed for ampère, the practical unit of electric current.

a.—A symbol proposed but not adopted for acceleration.

The defining equation is $a = \frac{V}{T}$

This letter is sometimes, though rarely, employed as the symbol for ampère.

α .—A symbol proposed for angle expressed in circular measure.

The defining equation is $\alpha = \frac{\text{arc}}{\text{radius}}$

A. h.—An abbreviation used for ampère hour, a commercial unit of electric quantity.

A. t.—An abbreviation for ampère-turn, a practical unit of magneto-motive force.

Abscissas.—Plural of abscissa.

Absorptive.—Possessing the power of absorption. (See *Absorption*.)

Acceleration, Angular — —The time rate of change of angular velocity.

Accumulation Method for Testing Joints in Electric Cables.—(See Appendix—*Method, Accumulation, for Testing Joints in Electric Cables*.)

Accumulator, Bi-Metallic — —A term applied to a secondary or storage cell in which two different metallic substances are employed in connection with a single elec-

trolytic fluid composed of a solution of a salt of one of the metals of the plates.

Many different bi-metallic accumulators have been designed; for example, the copper-lead accumulator, in which plates of copper and lead are immersed in an electrolyte of copper sulphate; or the copper-zinc accumulator, in which plates of zinc and copper are immersed in an electrolyte of zinc sulphate; or the zinc-lead accumulator, in which plates of zinc and lead are immersed in an electrolyte of zinc sulphate.

Accumulator, Charge — — A term sometimes employed for a Leyden jar or condenser. (See *Jar, Leyden, Condenser*.)

Accumulator, Copper-Lead — —An electro-chemical or electrolytic accumulator consisting of plates of copper and lead immersed in a solution of copper sulphate.

Accumulator, Copper-Zinc — —An electro-chemical or electrolytic accumulator consisting of plates of copper and zinc immersed in a solution of zinc sulphate.

Accumulator, Current — —A term sometimes employed for a Barlow wheel when used as an electrical accumulator. (See *Accumulator*.)

A series-wound dynamo-electric machine constitutes in reality a current accumulator.

Accumulator, Electro-Chemical — —

The name generally given to the ordinary secondary or storage battery, in which the difference of potential is produced by chemical action. (See *Cell, Storage*.)

Accumulator, Electrolytic — — An electro-chemical accumulator. (See Appendix—*Accumulator, Electro-Chemical*.)

Accumulator, Storage — — A term sometimes employed for storage cell. (See *Cell, Storage*.)

Accumulator, Zinc-Lead — — An electrolytic accumulator consisting of plates of zinc and lead immersed in a solution of zinc sulphate.

Acoustic Interference.—(See Appendix—*Interference, Acoustic*.)

Acoustic Resonance.—(See Appendix—*Resonance, Acoustic*.)

Acoustic Telegraph.—(See Appendix—*Telegraph, Acoustic*.)

Actinometer.—An instrument devised to measure the relative intensity of the sun's rays, or of such artificial light as the electric light, etc., etc.

The actinic power of the sun's rays to cause chemical decomposition varies with the condition of the atmosphere and the position of the sun above the horizon.

Action, Gyrostatic, of Dynamos on Ship-board — — The action which occurs at the bearings of a dynamo running on board a tossing ship, whereby gyrostatic stresses are set up.

Action, Protective — — A term proposed for the protective action afforded by a magnetic field to paramagnetic metals when exposed to chemical action.

The proposed term is not good in view of the fact that it is used to cover a number of other kinds of protective actions.

Experiments as to the protective action of a magnetic field on iron, nickel and cobalt were undertaken by Prof. Rowland and Dr. Bell. The results of these experiments, as stated by the experimenters, are as follows :

“When the magnetic metals are exposed to action in a magnetic field, such action is decreased or arrested at any points where the ratio of the variation of the square of the magnetic force tends towards a maximum.”

The results obtained by Rowland and Bell were apparently at variance with some more recent experiments of Squier, and showed that the currents produced by couples of similar metals when exposed to chemical action in a magnetic field had a direction of flow through the liquid from the magnetized to the non-magnetized electrode—*i. e.*, in the opposite direction to that pointed out by Squier in the phenomena of the protective throw. (See Appendix—*Throw, Protective*.)

Adielectric.—A term proposed for substances that are not dielectrics, that is, substances whose electric conductivity at ordinary temperatures decreases as the temperature increases.

Adjustable Rheostat.—(See Appendix—*Rheostat, Adjustable*.)

Aelotropic.—Heterogeneous with respect to direction.

Aelotropic Medium.—(See Appendix—*Medium, Aelotropic*.)

After-Working of Dielectric.—(See Appendix—*Dielectric, After-Working of*.)

Age-Coating of Chamber of Incandescent Electric Lamp.—(See Appendix—*Chamber of Incandescent Electric Lamp, Age-Coating of*.)

Ageing of Incandescent Electric Lamp.—(See Appendix—*Lamp, Incandescent Electric, Ageing of*.)

Agglomerate Leclanché Voltaic Cell.—(See Appendix—*Cell, Voltaic, Agglomerate Leclanché*.)

Air Telegraphy.—(See Appendix—*Telegraphy, Air*.)

Alarm, Frost — — An alarm sounded or set in operation by means of mechanism operated by a fall of temperature to or below 32° F.

Alarm, Photo-Electric — — A selenium

cell proposed for use in connection with the circuit of an electric source and suitable electro-receptive devices, so as to permit the passage of a stronger current through the circuit and the consequent sounding of an alarm on the exposure of one of its faces to the light.

By means of this device a burglar, carrying a light, can be made automatically to ring an alarm bell, and thus call the attention of a watchman or policeman to his presence.

Allotropism.—Allotropy. (See *Allotropy*.)

Alternating Current Arc.—(See Appendix—*Arc, Alternating Current*.)

Alternating Current Potentiometer.—(See Appendix—*Potentiometer, Alternating Current*.)

Alternating Current Rotary Transformer.—(See Appendix—*Transformer, Alternating Current Rotary*.)

Alternating Electromotive Force.—(See Appendix—*Force, Electromotive, Alternating*.)

Alternation, Periodicity of — —The number of alternations per second produced by a generator.

The term periodicity of alternation is synonymous with frequency, a briefer and more commonly employed word.

When any particular periodicity or frequency is spoken of, as, for example, 250 alternations per second, 125 complete periods or cycles per second are meant.

Commercially, the word alternations is used for half-periods or double-frequencies. A dynamo with 250 alternations per second has 125 periods per second.

Alternations, Co-phasal — —Alternations whose electromotive forces similarly and simultaneously vary.

The maximum and minimum electromotive forces of co-phasal alternations are both simultaneously and similarly directed.

Any number of periodic functions are said

to be co-phasal when the ratio between their instantaneous values is constant; when one is a maximum all the remainder will be maxima, and when one is a minimum all the remainder will be minima.

Alternator, Compensated — —An alternating current dynamo-electric machine for sustaining a uniform voltage at some point of its circuit under varying loads, in which the field magnets are excited partly by rectified or commuted currents taken from separate armature coils, and partly by currents furnished by the commuted current from a small transformer, whose primary coil is placed in the main circuit.

Alternator, Compound — —An alternating current dynamo-electric machine whose field magnets are compound-wound.

The current from the machine is commonly run through a series transformer whose secondary winding is connected with the field magnets through a commutator.

Alternator, Magnetic — —An alternating dynamo-electric machine in which permanent field magnets are employed.

Alternator, Magneto — —A term sometimes employed for magnetic alternator. (See Appendix—*Alternator, Magnetic*.)

Alternator, Multiphase — —An alternating current dynamo capable of producing multiphase currents.

Alternator, Separate-Coil — —An alternating current dynamo-electric machine in which the field magnets are excited by means of current taken from the coils on the armature, which current is first rectified, or caused to flow in one and the same direction, by means of a commutator.

Alternator, Separately-Excited — —An alternating current dynamo-electric machine in which the field magnets are excited by means of current furnished from a separate source.

Alternator, Two-Phase — — An alternating current dynamo capable of producing two-phase currents.

The term di-phase alternator would appear to be preferable.

Alternators, Parallel Connection of — — The connection of two or more alternating current dynamo-electric machines in parallel, so as to form a single electric source.

When two alternating current dynamo-electric machines are connected in parallel, if the armature self-induction and resistance are not too high, and the engines driving the dynamos are under control, or in other words governed, then such machines, even if out of synchronism, when connected, will almost immediately pull each other into synchronism, each promptly exercising an automatic control over the other.

When alternators possess marked synchronizing power, care must be exercised to adjust them fairly to equality of E. M. F. and phase, in order that they may not be injured by mechanical shock due to excessive cross currents, when first connected in parallel. A certain amount of armature self-induction is therefore desirable to render parallel working safe.

It is a matter of prime importance in the parallel running of alternators that the shape of the wave of E. M. F. is the same in all machines. Otherwise cross currents will flow between the machines under all adjustments. A difficulty is occasionally experienced in the parallel connection of alternators of different size, due to differing wave form.

Alternators, Parallel, Hunting of — — A periodical increase and decrease in the speed of alternators when running in parallel connection as motors or as dynamos under certain conditions.

Alternators, Series Connection of — — The connection of two or more alternating current dynamo-electric machines in series, so as to form a single electric source.

The series connection of alternating dynamo-electric machines is impracticable in or-

dinary work; for, should such connection be made when the two machines are furnishing currents in the same phase, as soon as either machine differs in the slightest degree in phase from the other such difference would tend to rapidly increase, until the two machines were in opposite phases, when, of course, no current would be produced. Hence, alternators can be run in series only when their armatures are mechanically and rigidly connected with each other.

Amalgamating Solution.—(See Appendix—*Solution, Amalgamating.*)

Amalgamator, Electric — — Any apparatus for the electrical treatment of gold or silver ores with mercury.

An electric amalgamator consists essentially of an amalgamator driven by electric instead of by ordinary mechanical power.

American Morse Code.—(See Appendix—*Code, American Morse.*)

Ammeter, Steel-Yard — — A form of ammeter in which the strength of the current is measured by means of the electromagnetic forces applied to one extremity of a steel-yard lever provided with sliding weights for balancing these forces.

Ampère, B. A. — — Such a current as would deposit 0.001118 gramme of silver per second from a neutral solution of nitrate of silver in distilled water.

This value of the ampère was adopted by the British Association at its meeting held in Edinburgh in August, 1892, the English Board of Trade, and by the Chicago Congress of 1893.

Equal to the international ampère.

Ampère-Centimetre.—A term proposed as a unit of magnetism.

The ampère-centimetre as a unit of magnetism is based on an assumption denied by some that any unit length of circuit, say one centimetre, conveying a unit current of one ampère, will generate a constant number of lines of magnetic force.

The proposed unit has not been accepted.

Ampère, International — — The value

of the international ampère adopted by the Chicago Congress of 1893 as equal to one-tenth of the unit of current of the C. G. S. system of electro-magnetic units, and which is represented sufficiently well for practical use by the unvarying current which when passed through a solution of nitrate of silver in water, and in accordance with certain specifications, deposits silver at the rate of 0.001118 of a gramme per second.

Ampère Meter, Milli — — An ampère meter, which measures in milli-ampères the current passing through it.

Ampère Yards. — (See Appendix—*Yards, Ampère.*)

Anæsthesia. — Insensibility, especially to pain.

Anæsthesia, Electric — — Nervous insensibility produced by means of electricity.

Local anæsthesia is obtained by means of induction apparatus in which the number of makes and breaks can be readily varied. It has been found in certain cases, when the makes and breaks follow one another with a given rapidity, which can be determined by means of the musical note produced, that such slight operations as the lancing of a felon can readily be performed without pain, after the part has been subjected to the action of the current for but a few minutes.

Anemograph, Electric — — An apparatus for electrically registering the direction and velocity of the wind.

Angle of Maximum Sensitiveness of Galvanometer. — (See Appendix—*Galvanometer, Angle of Maximum Sensitiveness of.*)

Angle, Phase — — The angle comprised between two different current maxima.

Angular Acceleration. — (See Appendix—*Acceleration, Angular.*)

Annunciator, Speaking-Tube — — An oral annunciator. (See *Annunciator, Oral.*)

Annunciator, Swinging — — A pendulum annunciator. (See *Annunciator, Pendulum.*)

Annunciator Wire. — (See Appendix—*Wire, Annunciator.*)

Anodic Rays of Vacuum Tube. — (See Appendix—*Rays, Anodic, of Vacuum Tube.*)

Anomalous Helix. — (See Appendix—*Helix, Anomalous.*)

Anomalous Solenoid. — (See Appendix—*Solenoid, Anomalous.*)

Anomalous Spiral. — (See Appendix—*Spiral, Anomalous.*)

Anti-Node. — The point on a vibrating body midway between two successive nodes. (See Appendix—*Node.*)

The point of maximum motion in a vibrating body.

Apparatus, Individual Signalling — — Any apparatus by means of which individual signals are operated. (See Appendix—*Signal, Individual.*)

Lockwood arranges the different methods according to which individual signals can be operated under the following heads, namely:

(1.) Signals operated at each sub-station or circuit with different strengths of current.

(2.) Signals operated by currents of opposed direction.

(3.) Signals operated both by changes in the strength and direction of the current.

(4.) Electro-magnetic step-by-step devices, acting to bring the sub-station signals to a ringing point differing for each sub-station, and then to close a local branch or shunt circuit, including a local bell, to operate alternating mechanism, or in some way to introduce a bell magnet into the circuit.

(5.) Signals operated by means of various arrangements of clockwork bells.

(6.) Signals operated by means of galvanometers, the movements of whose needles cause bells to ring.

To which may be added, signals operated by currents of different periodicity.

Apparatus, Polyphase — — Apparatus

operated by polyphase currents. (See Appendix—*Currents, Polyphase.*)

Apparatus, Selective Signalling — —A term sometimes used in place of individual signalling apparatus. (See Appendix—*Apparatus, Individual Signalling.*)

Apparent Resistance.—(See Appendix—*Resistance, Apparent.*)

Arc, Alternating Current — —An arc formed by means of an alternating current.

Since in the alternating current the electrodes become alternately positive and negative, neither carbon in the case of a carbon arc is markedly brighter than the other, and the rate of consumption of both carbons is the same.

Arc, Carbon — —A voltaic arc formed between two carbon electrodes.

The carbon voltaic arc is the one ordinarily employed, and is formed through a cloud of volatilized carbon. (See *Arc, Voltaic.*)

Arc, Common, of Aurora Glory — —The inner or common arc of an aurora glory. (See Appendix—*Glory, Aurora.*)

Arc, Continuous Current — —A voltaic arc produced by means of a continuous electric current.

In a continuous current arc the light is principally emitted from a crater in the positive carbon.

Arc, Copper — —A voltaic arc formed between two copper electrodes.

A copper arc is formed through a cloud of volatilized copper. Most metallic arcs are longer than carbon arcs. They possess the characteristic color of the volatilized metal; for example, the copper arc is green. (See *Arc, Voltaic.*)

A copper or other metallic arc would be formed from copper or other metallic rod if it formed the positive electrode, and a block of carbon or other non-metallic substance formed the negative electrode, since it is the material of the positive electrode that is volatilized.

Arc Lighting Dynamo-Electric Machine.

—(See Appendix—*Machine, Dynamo-Electric, Arc Lighting.*)

Arc, Two Thousand Candle Power, Proposed Definition for — —The light of an arc produced by 10 ampères of current and 45 volts potential difference between the carbons.

A 450-watt arc restricted as above.

Such an arc is sometimes called a full arc.

The difficulty in measuring the photometric intensity of a continuous current carbon arc is so great that considerable controversy has arisen as to whether or not a given candle power is present in certain cases. This difficulty arises not only from the fact that the light is of much greater intensity in certain directions than in others, but also from the fact that the candle power of an arc having a certain watt value may differ greatly with the quality of the carbons employed.

The adoption of the above definition would, therefore, seem to be extremely advisable.

Armature, Balanced — —An armature of an electro-magnet whose motion toward or from the magnetic poles is opposed by the pull of a spring, or the action of a weight, so that on the cessation of the magnetic attraction the armature will be caused to assume the position it had before the magnetic action began.

Strictly speaking, such an armature is not balanced; the term, however, is a convenient one.

Armature, Balanced — —An armature of a dynamo-electric machine so constructed or adjusted that the line joining the centres of inertia of all its cross sections practically coincides with the axis of rotation.

A balanced dynamo armature runs smoothly and without mechanical jars or vibrations.

Armature, Balanced — —An armature of a dynamo or motor in which the winding is such as to insure electrical symmetry.

Armature, Coreless, of Dynamo or Motor — —An armature of a dynamo or motor

not provided with a core of iron or other magnetizable material.

Armature, Di-Phase — — An armature of a motor wound so as to be operated by di-phase currents.

Armature, Magnetic Sticking of — — The adherence of the armature of an electro-magnet to the poles, after the current has ceased to pass through the magnetizing coils.

The cause of sticking is to be ascribed to the residual magnetism.

Sticking is sometimes avoided by means of core pins, or by a non-magnetizable coating of armature or core. (See Appendix—*Pins, Core.*)

Armature, Polyphase — — An armature of a motor wound so as to be operated by polyphase currents.

Armature Reaction.—(See Appendix—*Reaction, Armature.*)

Armature, Three-Phase — — A tri-phase armature. (See Appendix—*Armature, Tri-Phase.*)

The term tri-phase armature would appear to be preferable.

Armature, Tri-Phase — — An armature of a motor wound so as to be operated by tri-phase currents.

Armature, Two-Phase — — A di-phase armature. (See Appendix—*Armature, Di-Phase.*)

The term di-phase armature would appear to be preferable.

Arms, Side — — A term applied to the supports for the bearings of railway motors.

Arrival Curve of Telegraphic Circuit.—(See Appendix—*Curve, Arrival, of Telegraphic Circuit.*)

Arriving Current of Telegraphic Circuit.—(See Appendix—*Current, Arriving, of Telegraphic Circuit.*)

Asbestos-Porcelain.—A porous substance somewhat resembling ordinary porcelain.

Asbestos-porcelain is made by obtaining asbestos fibres in an exceedingly fine powder and forming this powder into a paste with water, consolidating it under heavy pressure, and subsequently exposing the dried particles to the effects of a high temperature.

Asbestos-porcelain, it is claimed, forms a material which, though resembling ordinary porcelain, is highly porous. It has been successfully used for the porous cells of voltaic batteries, for which purposes it is claimed to offer a better conducting path for the current than the ordinary unglazed earthenware generally employed for such purposes. (See *Cell, Porous.*)

Astatic Multiplier.—(See Appendix—*Multiplier, Astatic.*)

Atmosphere, Electric — — A term formerly employed for a space filled with electric effluvia. (See Appendix—*Effluvia, Electric.*)

A term sometimes employed for an electro-static field.

A space occupied by or permeated with electric sparks or glow.

Atmosphere, Magnetic — — A term formerly employed for a space filled with magnetic effluvia. (See Appendix—*Effluvia, Magnetic.*)

A term sometimes employed for a magnetic field.

Atom, Dyad — — An atom whose valency, atomicity or combining power is two. (See *Atomicity. Element.*)

Atom, Heptad — — An atom whose valency or atomicity is seven. (See *Atomicity. Element.*)

Atom, Hexad — — An atom whose valency or atomicity is six. (See *Atomicity. Element.*)

Atom, Monad — — An atom whose valency or atomicity is one. (See *Atomicity. Element.*)

Atom, Pentad — — An atom whose valency or atomicity is five. (See *Atomicity. Element.*)

Atom, Tetrad — —An atom whose valency or atomicity is four. (See *Atomicity. Element.*)

Atom, Triad — —An atom whose valency or atomicity is three. (See *Atomicity. Element.*)

Atomic.—Of or pertaining to the atom. (See *Atom.*)

Attachment, Electric Clamp — —A device employed in connection with a floor push, adapted for ready clamping to a table or other support for the purpose of holding a push button electrically connected with the floor push.

Attachment Plug.—(See Appendix—*Plug, Attachment.*)

Audible Telegraphic Signal.—(See Appendix—*Signal, Telegraphic, Audible.*)

Audiometer.—A word sometimes used in place of Sonometer. (See Appendix—*Sonometer.*)

Aura, Electric — —A term formerly employed for the breeze produced by electric convection. (See *Convection, Electric.*)

Aurora, Electrostatic — —A luminous phenomenon attending the production of an electrostatic corona. (See Appendix—*Corona, Electrostatic.*)

Aurora Glory.—(See Appendix—*Glory, Aurora.*)

Aurora, Polar — —A term sometimes used indifferently for the aurora borealis, or the aurora australis.

Austral Fluid.—(See Appendix—*Fluid, Austral.*)

Auto-Exciting.—Self-exciting.

Auto-Induction.—(See Appendix—*Induction, Auto.*)

Automatic Guard for Series-Connected Incandescent Lamps.—(See Appendix—*Guard, Automatic, for Series-Connected Incandescent Lamps.*)

Automatic Photo-Electric Switch.—(See Appendix—*Switch, Automatic Photo-Electric.*)

Automatic Repeater.—(See Appendix—*Repeater, Automatic.*)

Automatic Telegraph.—(See *Telegraph, Automatic.*)

Automatic Telegraphic Transmitter.—(See Appendix—*Transmitter, Automatic Telegraphic.*)

Auto-Reversible or Multiple Tele-Radiophone.—(See Appendix—*Tele-Radiophone, Auto-Reversible or Multiple.*)

Axial Current.—(See Appendix—*Current, Axial.*)

B

\mathfrak{B} .—A symbol employed for magnetic induction,

The defining equation is $\mathfrak{B} = \mu \mathfrak{H}$

B. A. Ampère.—(See Appendix—*Ampère, B. A.*)

B. A. Ohm.—(See *Ohm, B. A.*) (See Appendix—*Ohm, B. A.*)

B. T. U.—A contraction for Board of Trade unit, the commercial unit of electrical work adopted by the British Board of

Trade, viz., the kilowatt-hour, or the amount of work which would be accomplished in one hour at the rate of one kilowatt.

This contraction is a bad one, since it is already employed for British thermal unit.

B. T. U.—A contraction for British thermal unit.

Back Magnetization.—(See Appendix—*Magnetization, Back.*)

Backing Pan.—(See Appendix—*Pan, Backing.*)

Backward Induction of Dynamo Armature.—(See Appendix—*Induction, Backward, of Dynamo Armature.*)

Bad Earth.—(See Appendix—*Earth, Bad.*)

Balance, Coulomb's Electric — — A term sometimes employed for Coulomb's torsion balance when used for measuring the force of electric repulsion. (See *Balance, Coulomb's Torsion.*)

Balance, Coulomb's Magnetic Torsion — — A name sometimes given to Coulomb's torsion balance when employed to measure the force of magnetic repulsion. (See *Balance, Coulomb's Torsion.*)

Balance, Duplex — — The condition of a line in duplex telegraphy, when sending signals leave the home instruments unaffected and ready for response to received signals.

Balance, Electro-Dynamic — — A balance form of electro-dynamometer. (See *Dynamometer, Electro. Balance, Centi-Ampère.*)

Balanced Armature. — (See Appendix—*Armature, Balanced.*)

Balancing Wire or Conductor.—(See Appendix—*Wire or Conductor, Balancing.*)

Barker's Revolving Contact Breaker.—(See Appendix—*Breaker, Contact, Barker's Revolving.*)

Barker's Wheel.—(See Appendix—*Wheel, Barker's.*)

Base, Socket — — A base for holding a lamp socket in position.

Basket, Dipping — — A perforated basket of non-corrosive material, employed for the reception of articles that are to be prepared for the process of electroplating by dipping them in the cleansing bath. (See *Dipping.*)

Basket, Stoneware Dipping — — A stoneware basket in which the articles are

placed that are to be subjected to the dipping process in electro-metallurgy. (See Appendix—*Basket, Dipping.*)

Bath, Electric Light — — A variety of electro-therapeutic bath, in which all the patient's body, except the head, is exposed to the radiant light and heat of a number of incandescent electric lamps placed inside a closed chamber or box.

By the use of the electric light bath it is claimed that the temperature of the body is rapidly increased, and that the effect on the skin is the same as that of sunshine. The therapeutic value of such a bath is, perhaps, to be questioned.

Battery, Compound — — A term proposed by Henry for a number of separate voltaic cells, coupled so as to form a single cell, in contradistinction to a single cell.

The term battery was originally sometimes loosely applied either to indicate a single voltaic cell, or a number of cells so joined together as to form a single electric source.

Indeed, the term is still loosely employed even at the present day by some writers. In the time of Henry the word battery was apparently indifferently applied to a single cell or a number of cells, and Henry proposed the term compound battery to distinguish between a single cell, or, as he called it, a battery, and a number of cells joined so as to form a single source, which he terms a compound battery, but which is to-day, by all careful writers, termed a battery.

Battery, Distant — — A battery employed in a telegraphic system at the receiving end of the line.

Battery, Dry — — A number of separate dry voltaic cells combined so as to act as a single source.

A dry pile. (See *Pile, Dry.*)

Battery, Element of — — (See Appendix—*Element of Battery.*)

Battery, Home — — The battery employed in a telegraphic system at the sending end of the line.

Battery, Polarization — — A term sometimes employed for a secondary or storage battery.

The term secondary or storage battery would appear to be preferable.

Battery, Secondary, Current Efficiency of — — The ratio between the ampère-hours of the discharge and the ampère-hours of the charge.

Battery, Secondary, Efficiency of — — The ratio between the amount of electrical work given out by a battery during its discharge, and the amount of work expended in charging it.

The efficiency of a secondary battery varies with the rates of charge and discharge; the higher these rates the lower the efficiency.

The efficiency of a secondary battery is obtained by dividing the amount of electrical work in joules or watt-hours, which a battery will produce after being charged, by the amount of similarly estimated electrical work expended in charging it. This is generally known as the watt-efficiency.

The current-efficiency is obtained by dividing the ampère-hours of the discharge by the ampère-hours of the charge.

Battery, Secondary, Watt-Efficiency of — — The ratio between the amount of electrical work in watt-hours a battery will yield after being charged, and the amount of work in watt-hours expended in charging it.

Battery Syringe.—(See Appendix—*Syringe, Battery.*)

Battery System for Electric Railway.—(See Appendix—*Railway, Electric, Battery System for.*)

Bead, Chain.—(See Appendix—*Chain, Bead.*)

Bead Lightning.—(See Appendix—*Lightning, Bead.*)

Bearing, Magnetic — — The angle included between the horizontal line from an observer to an object and the observer's magnetic meridian.

Bega.—A prefix proposed by Houston and Kennelly for a thousand million, or 10^9 .

Begadyne.—A term proposed by Houston and Kennelly for one thousand million dynes, or 10^9 dynes.

Begerg.—A term proposed by Houston and Kennelly for one thousand million ergs, or 10^9 ergs.

Beginning of Current.—(See Appendix—*Current, Beginning of.*)

Begohm.—A term proposed by Houston and Kennelly for one thousand million ohms; i. e., 10^9 ohms.

Bell, Electric, Continuous Action — — An electric bell which continues to ring when once started until stopped either by hand or automatically.

Bell, Extension — — A term sometimes employed for extension call bell. (See *Bell, Extension Call.*)

Belt, Creeping of — — An action of a belt due to its retractility, whereby the driving pulley travels somewhat faster than the driven pulley.

Suppose the belt possesses true elasticity or retractile power, then it will be stretched on the work side and come back to its original length on the idle side. It therefore reaches the driving pulley in a stretched condition and leaves it in a contracted condition. It also reaches the driven pulley in a contracted condition and leaves it in an elongated condition. Suppose this stretch or elongation is one per cent. in a given case, the driving pulley must move 101 feet for every 100 feet of the driven pulley, then there is no slip of the belt, only a creep.

The slip of a belt may cause a considerable loss of peripheral velocity in the pulley.

Belt, Slipping of — — The slipping of a belt on the revolving pulley it covers, causing a loss of speed.

Bicro.—A prefix proposed by Houston and Kennelly denoting the thousand-millionth part, or 10^{-9} .

Microfarad.—A term proposed by Houston and Kennelly for the thousandth part of a microfarad, or 10^{-9} farad.

Microhenry.—A term proposed by Houston and Kennelly for the thousand-millionth part of a henry, or one centimetre.

Bi-Metallic Accumulator.—(See Appendix—*Accumulator, Bi-Metallic.*)

Biologist, Electro — —One skilled in the art of electro-biology.

Bioscopist, Electro — —One skilled in the science of electro-bioscopy.

Blavier's Formulæ.—(See Appendix—*Formulæ, Blavier's.*)

Blavier's Test.—(See Appendix—*Test, Blavier's.*)

Block, Ceiling — —An attachment fastened to ceilings for suspending flexible cords and connecting them with the supply wires of an incandescent system.

Block, Double, Duplex — —In telegraphy, especially in submarine telegraphy, duplex transmission obtained by the aid of a condenser inserted in each arm of the Wheatstone balance. (See *Telegraphy, Duplex, Bridge Method of.*)

Block, Service — —The set of terminals from which service wires are taken to the interior of a building, usually secured to a pole or to the exterior of a building.

Blow, To — —A phrase frequently employed to indicate the fusion of a safety fuse. (See *Fuse, Safety.*)

Blowing of Fuse.—(See Appendix—*Fuse, Blowing of.*)

Blowing Point of Fuse.—(See Appendix—*Fuse, Blowing Point of.*)

Blue Magnetic Pole.—(See Appendix—*Pole, Magnetic, Blue.*)

Board, Distributing — —A term sometimes employed in a system of telegraphic or telephonic communication for a cross connecting board. (See *Board, Cross-Connecting.*)

Board, Distributing Switch — —A switch board employed for distributing electric current to different circuits.

A distributing switch board is usually provided with wedge-plugs and spring-jacks.

Board, Lightning Arrester — —In a system of telephonic or telegraphic communication the board to which the lightning arrester is connected.

The lightning arrester board often forms part of the test-board.

Board, Test — —In a system of telephonic or telegraphic communication the board, provided with devices for readily connecting testing instruments to any particular line, to which all the separate lines are connected.

Bob, Polishing — —A disc of hard, tough wood, provided on its edge with a ring or rim of tough leather or hide, and employed, when mounted on a shaft and put into rapid rotation, for polishing articles so as to prepare them for electroplating. (See *Plating, Electro.*)

The polishing bobs are charged for use with any suitable abrasive material, such as emery, etc.

Bobbed.—A word sometimes employed to characterize a surface that has been polished by the action of a bob. (See Appendix—*Bob, Polishing.*)

Body, Inducteous — —A term proposed by Faraday for a body in which a charge is induced by the action of a neighboring charged body.

Body, Inductive — —A term proposed by Faraday for the body containing the inducing electric charge.

Bolognian Stone.—(See Appendix—*Stone, Bolognian.*)

Bond, Electric Rail — —An electric bond or connection between contiguous rails of a road using a grounded return.

In a system of electric roads, where the return circuit is grounded, the track offers an

excellent return provided the return joints between contiguous rails are electrically connected. To do this thoroughly, requires, of course, such an electric connection as will render the bonds of no higher linear resistance than the main body of the rails.

Bony Current.—(See Appendix—*Current, Bony.*)

Booster.—A scarcely euphonious word employed to designate a dynamo inserted in a special feeder or group of feeders of an Edison incandescent system in order to raise the pressure above the rest of the system.

Boreal Fluid.—(See Appendix—*Fluid, Boreal.*)

Bougie-Metre.—A name proposed for the practical unit of illumination.

A unit of illumination equal to the normal illumination from the bougie-decimale at a distance of one metre.

This unit was proposed by a Sub-Committee of the American Institute of Electrical Engineers on the provisional programme of the Chicago International Electrical Congress of 1893, on the occasion of the World's Columbian Exposition.

The bougie-decimale is practically equal to one English standard candle. By making the distance equal to one metre, the practical unit of illumination will be approximately equal to $\frac{1}{10}$ carcel-metre, or one metre-candle, or to one metre-kerze.

Bow, Voltaic — —A voltaic arc. (See *Arc, Voltaic.*)

Bowl, Stoneware Dipping — —A perforated bowl made of stone or earthen ware in which articles are placed that are to be subjected to the dipping process in electro-metallurgy. (See *Dipping.*)

Box, Section — —In a system of electric street railways the box containing the section switches and fuses used for the control of a section or a line section.

Box, Starting, of Shunt-Wound Motor

— —A box provided with a rheostat or variable resistance.

The armature resistance of a shunt-wound motor is generally made very low, in order to insure high efficiency and constancy of speed. In starting the motor, if it is connected to the constant potential circuit and the driving current be permitted to pass directly through its armature, the rush of current would be sufficient to injure the machine. To avoid this the current is first sent through a rheostat, or starting box, and, when the speed of the motor is sufficiently high, and a suitable counter-electromotive force is generated in the armature, the resistance coils are gradually cut out until the motor is connected directly to the constant potential mains.

Branched Series.—(See Appendix—*Series, Branched.*)

Break Key.—(See Appendix — *Key, Break.*)

Break, Quick — —A break of a circuit obtained by means of a quick-break switch. (See Appendix—*Switch, Quick-Break.*)

Breaker, Contact — —Any device for opening or breaking an electric circuit.

Breaker, Contact, Barker's Revolving — —A form of contact breaker in which a toothed wheel is rapidly revolved so that its teeth pass successively into and out of a mercury surface, and a rapid making and breaking of an electric circuit connected therewith is thus obtained.

Breaking Down of Dielectric.—(See Appendix—*Dielectric, Breaking Down of.*)

Bridge, Thomson's — —A modified form of Wheatstone's bridge proposed by Kelvin for the measurement of very small resistances.

Broiler, Electric — —A device for broiling by means of electrically generated heat.

Rods of insulated metal are suitably connected in parallel, and raised to incandescence

by means of electrically generated heat. (See *Heat, Electric.*)

In one form of apparatus made, when a potential difference of 110 volts is applied to the terminals, a current of seven ampères passes and heats the broiler sufficiently for use in about three or four minutes.

Brush, Cup — —A brush employed in cleansing surfaces that are to be prepared for electro-plating, and suitably shaped for polishing the inside of a cup or other similar hollow surface.

Brush, Inside Box — —A brush employed in cleansing surfaces so as to prepare them for electro-plating, suitably shaped for polishing the inside of tubular surfaces.

Brush, Potash — —A brush employed in cleansing, by the use of a caustic, surfaces that are to be electro-plated.

Brush, Thimble — —A brush employed in cleansing articles that are to be prepared for electro-plating, and suitably shaped for such surfaces as the inside of a thimble.

Brushes, Distributing, of Electric Motor — —The brushes of an electric motor corresponding in position to the collecting brushes of a dynamo-electric machine.

It is evident that the brushes of an electric motor differ somewhat in their function from the collecting brushes of a dynamo-electric machine, since in the former case the brushes act to distribute a current generated outside the motor to certain coils on the armature of the motor, while in the latter case they commute the direction of the current generated in the armature.

Brushes, Finishing — —A term employed in electro-plating for finer brushes than scratch brushes.

Bucking.—A word employed in the operation of street railway passenger cars for the sudden stopping of a car, as if by a collision.

The car sometimes refuses to go further; it often, however, stops and then goes ahead again almost immediately as if nothing had occurred. The cause of bucking is to be ascribed to the fact that the armature being grounded, if a second ground occurs in any part of the machine, between the armature and the trolley, with the ordinary method of connecting up, a heavy current flows, producing an intensely strong magnetic field and at the same time the armature is short circuited by means of the two ground connections. Under these circumstances the dynamo, being short circuited, operates as a powerful electro-magnetic brake. This effect also occurs when the armature is short-circuited by heavy sparking at the brushes, or bad insulation (not to ground) in the commutator.

The term bucking is sometimes used loosely for any cause which prevents an electric motor from properly operating.

Buffing.—Preparing surfaces for the reception of an electro-plating by subjecting them to the polishing action of a revolving wheel covered with a buff on the surface of which rouge has been spread.

Building Iron.—(See Appendix—*Iron, Building.*)

Building Process for Moulds of Electrotypes.—(See Appendix—*Process, Building, for Moulds of Electrotypes.*)

Buoy, Electrically Illumined — —A buoy illumined by means of an electric incandescent lamp.

The electric buoys are connected with the generating station on the shore by means of heavily armored cables. Spar buoys have been successfully lighted by such means.

Burglar Alarm Contacts.—(See Appendix—*Contacts, Burglar Alarm.*)

Burglar Alarm Matting.—(See Appendix—*Matting, Burglar Alarm.*)

Burglar Alarm Trap.—(See Appendix—*Trap, Burglar Alarm.*)

Burned-Out Incandescent Lamp.—(See

Appendix—*Lamp, Burned-Out Incandescent.*)

Burnishing.—A word employed in electro-plating for a process by means of which surfaces are prepared for electro-plating by subjecting them to the action of burnishing tools.

The burnishing action consists essentially in smoothing and brightening a surface by crushing down the small inequalities of the surface. The burnishing action is not unlike the smoothing action of a hot iron in ironing.

Button, Commutator-Press — —A form of press button in which the current from a battery or other source is reversed

in direction to the current previously flowing from the ordinary signalling button.

Button, Push, Double-Contact — —A push button provided with two contacts.

Button Repeater.—(See Appendix—*Repeater, Button.*)

Buzz.—A verb expressive of the action of an electric bell when it fails to strike distinctly and only gives a sound something like that of a buzzer.

An electric bell will “buzz” if the contacts are out of proper adjustment, or if the current passing is too strong.

By-Pass of Discharge.—A term sometimes employed for alternative path. (See *Path, Alternative.*)

C

C.—A symbol used for capacity.

The defining equation is $C = \frac{Q}{E}$

The same symbol is also used for current.

C.—A symbol used for coulomb, the practical unit of electric quantity.

The same symbol is also used for current and proposed for capacity.

cm.—An abbreviation frequently employed for the centimetre, the C. G. S. unit of length.

cm².—An abbreviation frequently employed for square centimetre, the C. G. S. unit of surface.

cm³.—An abbreviation frequently employed for cubic centimetre, the C. G. S. unit of volume.

cm : s.—An abbreviation frequently employed for centimetre per second, the C. G. S. unit of velocity.

cm : s².—An abbreviation frequently employed for centimetre per second per second, the C. G. S. unit of acceleration.

C² R Loss.—(See Appendix—*Loss, C²R.*)

Cable, Concentric — —A cable provided with both a leading out and a return conductor, one forming a central core or conductor and the other an enclosing tubular conductor, suitably insulated from each other.

In a concentric cable the central conductor is heavily insulated and enclosed in a metallic tube which latter acts as a return conductor.

Cable, Linear Capacity of — —The quotient of the capacity of a cable by its length.

Cable, Linear Insulation of — —The product of the insulation resistance of a cable and its length.

The linear insulation is preferably measured in kilometre megohms, or mile megohms.

Cage Protector for Lightning Discharges.—(See Appendix—*Protector, Cage, for Lightning Discharges.*)

Callan Voltaic Cell.—(See Appendix—*Cell, Voltaic, Callan.*)

Callan's Electro-Magnetic Repeater.—(See Appendix—*Repeater, Electro-Magnetic, Callan's.*)

Calorimetry.—The science of measuring quantities of heat. (See *Calorimeter*.)

Capacitance.—A term analogous to resistance, proposed by Hospitalier for the true or specific capacity of a medium.

Capacity for Heat, Mean Thermal — — The mean thermal capacity for heat of a body between two stated temperatures is the quantity of heat required to raise it from the lower of these temperatures to the higher, divided by the difference of temperatures. (See *Heat, Specific*.)

Capacity, Kilometric, of Cable — — The capacity of a cable in microfarads per kilometre. (See *Cable, Electric*.)

Capacity, Magneto-Inductive — — A term sometimes employed for magnetic permeability. (See *Permeability, Magnetic*.)

The word permeability is preferable.

Capacity, Specific Dielectric — — A term sometimes employed in place of specific inductive capacity. (See *Capacity, Specific Inductive*.)

Carbon Arc.—(See Appendix—*Arc, Carbon*.)

Carbon Pencil.—(See Appendix—*Pencil, Carbon*.)

Carbons, Skew Adjustment of, in Arc Lamp — — The adjustment of the carbons of an arc lamp by means of which the positive carbon is placed a short distance in front of, back and out of a vertical line with, the negative carbon.

The skew adjustment is employed in a projector or search light for the purpose of insuring the formation of the crater on the edge of the positive carbon so that the principal part of the light is thrown out horizontally.

Cardan's Suspension of Compass Needle.—(See Appendix—*Suspension of Compass Needle, Cardan's*.)

Carrying Capacity of Safety Fuse.—(See Appendix — *Fuse, Safety, Carrying Capacity of*.)

Casting, Electric — — A process for the casting of metals that have been fused by means of heat of electric origin.

The metals are fused by heat in a specially provided furnace from which all the air has been exhausted. The fused metal is then run into moulds from which the air has also been exhausted.

The vacuum and the electric melting, it is claimed, produce a greater liquidity of the metal than do the ordinary methods, and hence insure a readier flow and more sharply marked castings. The metal of the casting is also for the same reason extremely close and fine grained, and is free from blow-holes.

Castor and Pollux Light.—(See Appendix—*Light, Castor and Pollux*.)

Cataphoric Electrode.—(See Appendix—*Electrode, Cataphoric*.)

Cataphoric Medication.—(See Appendix—*Medication, Cataphoric*.)

Ceiling Block.—(See Appendix—*Block, Ceiling*.)

Ceiling Rosette.—(See Appendix—*Rosette, Ceiling*.)

Cell, Double-Liquid — — A term sometimes employed in place of double-fluid cell. (See *Cell, Voltaic, Double-Fluid*.)

Cell, Dry Gelatine — — A term applied to a type of dry voltaic cell in which the exciting liquid is absorbed by, or combined with, a variety of gelatinous substances.

The term gelatine dry cell is by no means limited to cases in which gelatine, either in whole or in part, forms the material for the retention of the exciting liquid. On the contrary, such cells most frequently contain a mixture of various mineral substances which on standing assume a gelatinous or semi-gelatinous condition from the water combining with the substances.

Cell, Earth — — A term frequently applied to a variety of cell consisting of any voltaic couple buried in a comparatively moist stratum of earth.

In such cases the moisture of the earth acts as the electrolyte and the electromotive forces developed depend on the character of the voltaic couples employed.

The term earth cell is sometimes improperly applied to the case of two similar metallic plates buried in the earth at considerable distances from one another. In such cases the current produced is obtained in part at least by means of the difference of potential caused between the two points of the earth at which the separate plates are located.

It is evident, however, that the current produced by such earth cells, improperly so-called, is in reality obtained from the earth as an electric source, the plates with their metallic terminals simply forming conductors for carrying off the current generated by the difference of potential already existing in the earth. (See *Currents, Earth.*)

Cell, Galvanic — —A term sometimes employed instead of voltaic cell. (See *Cell, Voltaic.*)

Cell, Gas — —A term sometimes applied to one of the cells of a gas battery. (See *Battery, Gas.*)

Cell, Lead Sulphate of Copper — —A form of storage cell in which two plates of lead are immersed in a solution of copper sulphate.

On the passage of the charging current one lead plate becomes coated with lead peroxide and the other with metallic copper. (See *Cell, Storage.*)

Cell, Lead Sulphate of Zinc — —A form of storage cell in which two plates of lead are immersed in a solution of zinc sulphate.

On the passage of the charging current one plate becomes coated with lead peroxide and the other with metallic zinc.

This cell, according to Reynier, has an electromotive force of as high as from 2.8 to 2.6 volts, but soon falls to from 2.3 to 2 volts. (See *Cell, Storage.*)

Cell, Light — —A term sometimes employed for a photo-electric cell. (See *Cell, Photo-Electric.*)

Radiant energy, whether of the luminous type, as in the case of light, or of the non-luminous type, as in the case of heat, produces a difference of potential under a variety of circumstances.

In some cases violet-colored light seems to produce the most marked effects.

Roughly speaking, photo-electric, or light cells, can be grouped into two fairly sharply marked classes, namely:

(1.) Those in which the electricity accompanies some chemical decomposition which acts to produce a current.

(2.) Those in which slight molecular changes occur which result in the production of an electric current.

The production of electricity in cells of the latter type, by the action of light alone, is probably analogous to the production of pyro-electricity in the case of certain crystalline bodies. (See *Electricity, Pyro.*)

Cell, Magneto-Chemical — —A cell invented by Balsamo, in which two similarly magnetized bars are immersed with the north pole of one and the south pole of the other in a solution of oxalic acid.

Under these circumstances the magnet having its north pole immersed in the exciting liquid acts like the zinc plate, and the one having its south pole like the copper of an ordinary zinc-copper couple immersed in dilute sulphuric acid.

The influence a magnetic fluid exerts on chemical action has been investigated by Rowland and Bell, and by Squier. (See Appendix—*Action, Protective. Throw, Protective. Throw, Concentration.*)

Cell, Photo-Electric Impulsion — —A term sometimes applied to an impulsion cell. (See *Cell, Impulsion.*)

Cell, Primary — —A term sometimes employed for a voltaic cell. (See *Cell, Voltaic.*)

The term primary cell is employed in contradistinction to secondary or storage cell. (See *Cell, Storage.*)

Cell, Regenerative — —A term proposed for an early form of storage or sec-

ondary cell, invented by Thomson and Houston, consisting of two plates of copper immersed in a solution of zinc sulphate.

Two plates were placed, one at the bottom of the solution, and the other near the top. On the passage of the charging current, one of the plates through the decomposition of the zinc sulphate was partially converted into copper sulphate and the other plate was coated with metallic zinc. The connections were such that the plate partially converted into zinc sulphate was placed at the bottom of the cell, and the one partially converted into and covered by metallic zinc, at the top.

The passage of the charging current thus produced a variety of gravity cell. On the exhaustion of the cell there remained two inert plates of copper immersed in a solution of zinc sulphate.

Cell, Thermo-Chemical — —A variety of heat cell in which a difference of potential is produced and maintained between two plates immersed in a suitable liquid when one plate is kept at a higher temperature than the other.

A heat cell forms in reality a species of storage battery in which the charging of the cell is obtained by the expenditure of heat energy.

In true heat cells a chemical action occurs which is readily and completely reversible by heat.

Cell, Voltaic, Agglomerate Leclanché — —A variety of Leclanché cell in which the mixture of carbon and dioxide of manganese is made into a solid mass by pressure.

The advantage claimed for the agglomerate Leclanché cell is that the porous cup employed in the other forms of this cell is dispensed with.

Cell, Voltaic, Callan — —A zinc-iron couple, the elements of which are immersed respectively in an electrolyte of dilute sulphuric acid, and an electrolyte consisting

of a mixture of strong nitric and sulphuric acids.

In the Callan cell the iron plays the part of the negative element. It is not attacked by the nitric acid provided the acid be sufficiently strong. The reasons generally assigned for the non-action of the acid on the iron are either the so-called passive state of the iron or the formation on the surface of an insoluble oxide. (See *State, Passive.*)

This cell is sometimes called the iron cell, or the Maynooth. It is difficult to maintain this cell in good action, owing to the liability of the nitric acid to act on the iron whenever its strength falls below a certain point.

Cell, Voltaic, Heat — —A cell in which heat energy is changed or converted into electric energy.

Park Benjamin divides heat cells into three classes, namely:

(1.) Those in which heat acts upon the materials of the cell by causing fusion or decomposition.

(2.) Those in which heat acts to set free chemical affinities whereby the cell is caused to operate, regeneration after exhaustion taking place at a lower temperature.

(3.) Thermo-chemical cells, or those in which the difference of potential is maintained between two plates immersed in a liquid by heating one plate to a higher temperature than the other.

Cell, Voltaic, Maynooth — —A name sometimes given to the Callan voltaic cell. (See Appendix—*Cell, Voltaic, Callan.*)

Cell, Voltaic, Single-Liquid — —A term sometimes employed in place of a single-fluid cell. (See *Cell, Voltaic, Single-Fluid.*)

Cessation of Current.—(See Appendix—*Current, Cessation of.*)

Chain, Bead — —A chain employed in connection with a pendant electric burner. (See *Burner, Plain Pendant Electric.*)

Chain, Galvanic — —A term formerly applied to a galvanic, or more properly

speaking, voltaic circuit. (See *Circuit, Voltaic*.)

Chamber of Incandescent Electric Lamp, Age-Coating of — —The gradual darkening of the enclosing glass chamber of an incandescent electric lamp.

This coating may be due to a deposit of carbon or a hydrocarbon, or a deposit of metal deflagrated or volatilized by the heat of the filament.

Charge Accumulator.—(See Appendix—*Accumulator, Charge*.)

Charge Current on Telegraphic Line.—(See Appendix—*Line, Telegraphic, Charge Current on*.)

Charge, Linear Density of — —The amount of electricity per unit of length of conductor. (See *Charge, Electric*.)

Charge, Minus — —A negative charge. (See *Charge, Negative*.)

Charge, Plus — —A positive charge. (See *Charge, Positive*.)

Charge, Sweeping-Out — —A phrase employed in double-current signalling for the freeing of the line from a charge produced by the sending of one signal, by reversing the direction of the current through the line.

The "sweeping-out" of the charge on a telegraphic line decreases the amount of retardation. (See *Retardation*.)

Charge, Volume Density of — —The amount of electricity per unit of volume. (See *Charge, Electric*.)

Check, Telephone Time — —A device by means of which, in a telephone exchange system, a drop shutter is automatically released at a particular trunk wire indicator, at the beginning of the time that a subscriber is given the use of the trunk line, and automatically disconnected, and the central station operator's attention is called to the fact of such disconnection.

By the use of the time-check, disputes as

to the length of time a subscriber is given the use of a trunk line is avoided.

A telephone time-check is sometimes called a telephone meter. (See Appendix—*Meter, Telephonic*.)

Chemical Generator of Electricity.—(See Appendix—*Generator, Chemical, of Electricity*.)

Chemical Telegraph.—(See Appendix—*Telegraph, Chemical*.)

Chemism. — A word sometimes employed for chemical affinity. (See *Affinity, Chemical*.)

Chemistry, Thermo — —That branch of chemistry which treats of the measurement of chemical energy in thermal units.

According to Berthelot :

(1.) The amount of heat set free in any chemical reaction is a measure of the total work done during that reaction.

(2.) Changes produced in any system not attended by external effects produce an evolution of heat dependent only on the initial and final states of the system.

(3.) Every chemical change effected in a system independent of external energy tends to produce that body or system of bodies, the formation of which evolves a maximum heat.

Choke Magnet.—(See Appendix—*Magnet, Choke*.)

Chronograph, Spark — —A form of electric chronograph in which the time of a certain event is indicated by means of the spark of a Ruhmkorff or spark coil.

In a form of spark chronograph for measuring the time in which a falling body moves through different parts of its path, the path of the body is marked on a moving sheet of paper by means of a series of sparks from a Ruhmkorff coil.

Chronometer, Electric — —An electrically controlled or operated mechanism for indicating or recording time. (See *Clock, Electric*.)

Circuit Closer.—(See Appendix—*Closer, Circuit.*)

Circuit Closer for Pull Bell.—(See Appendix—*Pull Bell, Circuit Closer for.*)

Circuit, Consumption — —A circuit in which the energy of the electric current is consumed or utilized for energizing electro-receptive devices.

Electric energy is consumed in all parts of an electric circuit. The term consumption circuit, however, is limited to that part of an electric circuit in which the electro-receptive devices are placed which are energized by the passage of the electric current through them.

Circuit, Electrical Tuning of — —(See Appendix—*Tuning of Electrical Circuit.*)

Circuit, Magnetic, External — —A term sometimes employed for that part of a magnetic circuit which lies outside of a magnet. (See *Circuit, Magnetic.*)

Circuit, Magnetic, Internal — —A term sometimes employed for that part of a magnetic circuit which lies within the magnet. (See *Circuit, Magnetic.*)

Circuit, Multiple-Parallel — —A term sometimes employed for a multiple of parallel circuits. (See *Circuit, Multiple.*)

Circuit, Parallel-Arc — —A term sometimes employed in place of parallel or multiple circuit. (See *Circuit, Multiple.*)

Circuit, Resonant — —A circuit whose dimensions are such as to bring it into resonance with, or to tune it to, the period of another circuit.

Circuit, Surging — —An electrical circuit through which electrical surgings are passing.

Lodge employs this term, surging circuit, in the following restricted sense.

“I have been accustomed especially to apply the name ‘surging circuit’ to the case where sparks are obtained not between two distinct parts of a circuit, but between two points on one and the same good conductor,

under circumstances when it does not form the alternative path to anywhere, and when it would ordinarily be supposed that there was no possible reason for a spark at all.”

The term surging circuit is applied generally to circuits through which surging discharges are passing; as, for example, the condenser-motor circuit in the Stanley-Kelley system.

Circuit, Telegraphic, Working Efficiency of — —The variation or margin between the joint resistance of the conductor and the resistance of the insulator by which the conductor is supported.

According to F. L. Pope the working efficiency may be increased in two ways, viz.:

(1.) By increasing the insulation resistance.

(2.) By decreasing the resistance of the conductor.

Circular Magnetization.—(See Appendix—*Magnetization, Circular.*)

Clamp, Feeder — —Any clamping device for connecting or fastening a feeder wire to a trolley wire.

Clip.—A slight break in the signal received in a system of duplex telegraphy under certain circumstances.

Clip, Feeder — —In a system of electric street railways a clamp furnished with a device whereby a feeder wire may be readily connected to a trolley wire.

Clips, Stay-Eye — —Iron bands clamped to the string beams of the roof with an iron ring projecting from the surface of the roof, to which the stay rods of telegraphic or telephonic standards are screwed.

Clock, Directing — —A term sometimes employed instead of controlling or master clock. (See *Clock, Electrical-Controlling.*)

Clock, Electric, Watchman's — —A watchman's electric register. (See *Register, Watchman's, Electric.*)

Clock, Primary Electric — —A term sometimes employed in place of the controlling or master clock. (See *Clock, Master*.)

Clock, Standard — —In a system of time telegraphy the master clock. (See *Clock, Master*.)

Closed-Circuit Transformer.—(See Appendix—*Transformer, Closed-Circuit*.)

Closed-Conducting Sheath for Lightning Protection.—(See Appendix — *Sheath, Closed-Conducting, for Lightning Protection*.)

Closer, Circuit — —Any device for completing or closing a circuit.

Clown's-Hat Curve.—(See Appendix—*Curve, Clown's-Hat*.)

Code, American Morse — —A term sometimes employed for the Morse telegraphic alphabet. (See *Alphabet: Telegraphic, Morse's*.)

Code, Dot-and-Dash — —A term sometimes employed for the Morse telegraphic code. (See *Code, Telegraphic*.)

Code, International Morse — —A term sometimes employed for the international telegraphic alphabet. (See *Alphabet, Telegraphic: International Code*.)

Coil, Faradic — —A term sometimes employed in place of a Faradic machine or medical induction coil. (See *Machine, Faradic*.)

Coil, Ground — — A small rheostat employed in duplex telegraphy at the home station for the purpose of giving the apparatus in such station an equal resistance to the currents coming from the distant station. (Pope.)

The resistance of the ground coil should be equal to the resistance of the spark coil, plus the internal resistance of the battery.

Coil, Induction Ribbon — —An induction coil, the primary and secondary cir-

cuits of which are made of metallic ribbons instead of wires.

Coil, Induction, Self — —A coil of wire possessing a self induction.

A choking coil. (See *Coil, Choking*.)

Coil, Spark, Telegraphic — —A small rheostat employed in duplex telegraphy at the home station in connection with the ground coil. (See Appendix—*Coil, Ground*.)

The resistance of the spark coil should be made sufficiently great to prevent the polarization of the battery when it is momentarily short-circuited.

Coils, Differential — —Coils that are differentially wound. (See Appendix—*Winding, Differential*.)

Coils, Field, of Dynamo — —The coils of wire wound on the field magnet cores for the production of the magnetic field.

Coked Core of Incandescent Filament.—(See Appendix—*Core, Coked, of Incandescent Filament*.)

Coked Filament.—(See Appendix—*Filament, Coked*.)

Coking, Electrical — —Subjecting a carbon to the coking process. (See Appendix—*Process, Coking, for Filament of Incandescent Electric Lamp*.)

Coking of Filament.—(See Appendix—*Filament, Coking of*.)

Coking Process for Filament of Incandescent Electric Lamp.—(See Appendix—*Process, Coking, for Filament of Incandescent Electric Lamp*.)

Collecting Combs.—(See Appendix—*Combs, Collecting*.)

Comazant.—A term formerly applied to St. Elmo's fire.

A corposant. (See *Corposant, Fire, St. Elmo's*.)

Combination Fittings for Chandeliers, Brackets, etc.—(See Appendix—*Fittings*,

Combination, for Chandeliers, Brackets, etc.)

Combs, Collecting — — A term sometimes employed for the collecting points of a frictional electrical machine, or of an electrostatic induction machine. (See *Machine, Frictional Electric. Machine, Electrostatic Induction.*)

Common Arc of Aurora Glory.—(See Appendix—*Arc, Common, of Aurora Glory.*)

Commutator Press-Button.—(See Appendix—*Button, Commutator-Fress.*)

Commutatorless.—Not provided with a commutator. (See *Commutator, Dynamo-Electric Machine.*)

Compass, Declination — — A declinometer. (See *Declinometer.*)

Compensated Alternator.—(See Appendix—*Alternator, Compensated.*)

Compensating-Alternating Dynamo-Electric Machine.—(See Appendix—*Machine, Dynamo - Electric, Compensating-Alternating.*)

Compensator, Magnetic — — A device for neutralizing the effects produced on a magnetic needle by the local magnetism of a ship.

Complex-Harmonic Alternating Electromotive Forces.—(See Appendix—*Forces, Electromotive, Complex-Harmonic Alternating.*)

Complex-Harmonic Currents.—(See Appendix—*Currents, Complex-Harmonic.*)

Complex-Magnetic Shell.—(See Appendix—*Shell, Complex-Magnetic.*)

Compound Alternator.—(See Appendix—*Alternator, Compound.*)

Compound Battery.—(See Appendix—*Battery, Compound.*)

Compound Electro-Magnet. — A term sometimes applied to an induction coil. (See Appendix—*Magnet, Electro-Compound.*)

Compound Magnet.—(See Appendix—*Magnet, Compound.*)

Concentration Throw.—(See Appendix—*Throw, Concentration.*)

Concentric Cable.—(See Appendix—*Cable, Concentric.*)

Concentric Wiring.—(See Appendix—*Wiring, Concentric.*)

Conductance, Specific — — Specific conductivity. (See *Conductivity, Specific.*)

Conductibility.—Possessing the power of conducting electricity.

Conductivity.

Conducting Cord and Tip.—(See Appendix—*Cord and Tip, Conducting.*)

Conducting Cord Tip.—(See Appendix—*Tip, Conducting Cord.*)

Conduction Lightning Protection.—(See Appendix—*Protection, Conduction Lightning.*)

Conduction Lightning Protector.—(See Appendix—*Protector, Conduction Lightning.*)

Conduction, Metallic — — A term sometimes employed for the conduction of electricity through a solid conductor in contradistinction to its conduction through an electrolyte. (See *Conduction, Electrolytic.*)

Conduction Resistance.—(See Appendix—*Resistance, Conduction.*)

Conductivity, Percentage, of Wire — — The conductivity of a particular copper wire compared with the conductivity of another wire of the same dimensions of pure material at a standard temperature.

The percentage conductivity is readily obtained by multiplying the calculated resistance of the pure material by 100 and dividing the result by the measured resistance of the particular wire.

Conductor, Electric, Glowing of — — Emitting light from any conductor heated to electrical incandescence.

The current strength required to produce a glow in a conductor varies in a marked manner with the character and density of the gas surrounding the conductor.

Conductor, Electric, Melting of — — Fusion of a conductor by means of the heat of electric currents.

The strength of current required to fuse or melt a conductor varies with a number of circumstances, so that a wire which will not fuse under the influence of a certain current strength may fuse at another time under a much smaller current strength if the conditions are different. Among these influences may be mentioned the nature of the medium surrounding the conductor, as well as the temperature of said medium. Sometimes, too, a coating of oxide forms on the surface of the conductor, which modifies its ability to throw off or radiate its heat.

When subjected to alternating currents a fuse wire has its fusing point gradually lowered.

Conductor, Electric, Volatilization of — — The volatilization of a conductor produced by the passage of an electric current through it.

The current required to volatilize a conductor will necessarily vary with the same circumstances that modify its electric glowing or melting. (See Appendix—*Conductor, Electric, Glowing of. Conductor, Electric, Melting of.*)

Conductor or Line Wire, Dip of — — The sag of a telegraphic or telephonic wire or conductor between two supports due to its weight.

Conductor Resistance.—(See Appendix—*Resistance, Conductor.*)

Conductor, Semi — — A term sometimes applied to substances, such as acids, saline salts, water, etc., whose power of conduction for electricity is neither very high nor very low.

Substances that occupy an intermediate position between conductors and so-called non-conductors for electricity.

Conductor, Stranding of — — Forming a conductor of several smaller conductors for the purpose of reducing the self-induction or eddy currents, or of increasing its flexibility. (See *Induction, Self.*)

Conductor System for Railroad.—(See Appendix—*Railroad, Conductor System for.*)

Conflict, Electric — — A term proposed by Oersted for a magnetic field surrounding a conductor through which a current of electricity is flowing.

Oersted speaks as follows of his discovery of the magnetic qualities of the region around a conductor through which an electrical current is flowing: "That this conflict performs circles around the wire, for without this condition it seems impossible that one part of the wire when placed below the magnetic needle shall drive its pole to the east, and when placed above it to the west."

Connector, Copper — — A particular form of connector employed in the gravity voltaic cell for connecting the copper element to the circuit wire or conductor.

A name applied technically to a form of electric light fitting or coupler for connecting large wires or conductors.

Consonance.—Literally, sounding at the same time.

Strictly speaking, two sounds are said to be in consonance when they are sounded together. In this sense we speak of pleasing consonances or harmonious chords. Often, however, the word consonance is used in contradistinction to dissonance as indicating two sounds that are in unison with each other.

The word consonance is also frequently employed in the sense of increasing or reinforcing a sound; such, for example, as the method of increasing the sound produced by a vibrating string or cord by stretching the cord over an elastic body like a table. In such cases the table takes up the motions or vibrations of the cord, and, by thus setting in motion a greater mass of air, increases the

amplitude of the waves and consequently the intensity of the sound. This use of the word consonance is to be distinguished from resonance, in which an increase in the intensity of the sound is also produced by waves or vibrations set up in another body with, however, this difference: in the case of resonance the re-enforcement is effected by vibrations set up in a body that is tuned to vibrate in exact unison with a vibrating body; while in the case of consonance no such tuning is necessary; or, briefly, consonant vibration is forced vibration, while resonant vibration is natural or free vibration excited by the vibrating body.

Consonator.—Any body possessing the power of increasing the strength of sound by consonance. (See Appendix—*Consonance*.)

This use of the word consonator is analogous to the use of the word resonator; viz., a body having the power of increasing the strength of sound by resonance. (See *Resonator*.) A consonator, however, differs from a resonator in the manner in which it strengthens the sound.

Constant-Potential Motor.—(See Appendix—*Motor, Constant-Potential*.)

Constant, Verdet's — — The magneto-optic constant of a transparent substance, usually expressed in minutes of arc rotation of the plane of polarization, for a luminous ray of definite wavelength through the magnetized substance at a definite temperature between points on the ray path whose magnetic potential differs by unity.

Verdet's constant is usually taken for the D line at the temperature of 15°C. Its value for monohydrated sulphuric acid according to Bichat, and Mascart and Joubert equals 0.0104'.

Consumption Circuit.—(See Appendix—*Circuit, Consumption*.)

Contact Breaker. — (See Appendix—*Breaker, Contact*.)

Contact, Drop Relay — — A form of

relay contact in which the attraction of an armature on the passage of a current releases a drop and thus completes a local circuit which remains closed until the drop is replaced or reset.

By the suitable combination of a drop relay and a bell, the bell may become a continuous ringing bell.

Contact, Floor — — A term sometimes employed in place of floor push. (See *Push, Floor*.)

Contact, Full — — A variety of fault produced by a part of the circuit being accidentally placed in contact with a good metallic circuit. (See *Contacts*.)

Contact, Relay — — A term frequently applied to a form of electro-magnetic instrument by means of which a local circuit is completed by the passage of a current.

A relay contact is in reality a form of key or push, which, instead of being opened or closed by means of the hand, is closed by means of an electro-magnet. Relay contacts are of two kinds, namely, spring relay contacts and drop relay contacts.

Contact Resistance.—(See Appendix—*Resistance, Contact*.)

Contact, Spring Relay — — A form of relay contact which is interrupted by the action of a spring, as soon as the current is broken.

Contact Theory of Electricity.—(See Appendix—*Theory, Contact, of Electricity*.)

Contact, Total — — A term sometimes employed for full metallic contact. (See *Contact, Full-Metallic*.)

Contact, Window or Blind — — A variety of burglar-alarm contact by means of which an alarm bell is rung by a slight pressure against a blind caused by any attempt to enter from without after having broken the glass in the window. (See *Alarm, Burglar*.)

Contacts, Burglar Alarm — — Contacts by means of which the opening or closing of a door or window, or the passage of a person across a given space, is caused to ring an alarm bell. (See *Alarm, Burglar.*)

Continuous Action of Electric Bell.—(See Appendix—*Bell, Electric, Continuous Action of.*)

Continuous Current Arc.—(See Appendix—*Arc, Continuous Current.*)

Continuous Current Transformer.—(See Appendix—*Transformer, Continuous Current.*)

Contracting Magnetic Whirl.—(See Appendix—*Whirl, Contracting Magnetic.*)

Contraction, Over-Maximal — — An increase in the electrical stimulation of a motor nerve beyond the point where an apparent maximum stimulus has been reached.

Between the condition of the first maximum and the second maximum an increase in the strength of the current is followed by a decrease in the stimulation. On, however, a further increase in the current strength a second increase in the contraction, termed the over-maximal contraction, occurs.

Contraplex Telegraph.—(See Appendix—*Telegraph, Contraplex.*)

Convection Transference.—(See Appendix—*Transference, Convection.*)

Conversion of Electromotive Force.—(See Appendix—*Force, Electromotive, Conversion of.*)

Conversion, Ratio of — — A term sometimes employed instead of ratio of transformation. (See Appendix—*Transformation, Ratio of.*)

Convert.—To transform or change.

Converter, Rotary — — A rotary transformer. (See Appendix—*Transformer, Rotary.*)

Converting.—Transforming or changing.

Co-phasal. — Two or more quantities which vary harmonically, and whose rates of increase or decrease at any given time maintain a constant ratio.

Co-phasal Alternations.—(See Appendix—*Alternations, Co-phasal.*)

Copper Arc.—(See Appendix—*Arc, Copper.*)

Copper Connector.—(See Appendix—*Connector, Copper.*)

Copper-Lead Accumulator.—(See Appendix—*Accumulator, Copper-Lead.*)

Copper Resistance.—(See Appendix—*Resistance, Copper.*)

Copper Shell of Electrotpe.—(See Appendix—*Shell, Copper, of Electrotpe.*)

Copper-Zinc Accumulator.—(See Appendix—*Accumulator, Copper-Zinc.*)

Cord and Tip, Conducting — — A conducting cord provided at one of its ends with a tip for the purpose of ready insertion in a wall socket.

Cord, Incandescent Lamp — — A flexible lamp cord of two strands suitable for use with a pendent incandescent lamp.

Core, Coked, of Incandescent Filament — — A filament for an incandescent electric lamp, formed of a core of electrically coked carbon, whose surface is covered with a deposit of carbon derived from the electrical decomposition of a hydrocarbon gas or vapor.

Core Loss of Transformer.—(See Appendix—*Loss, Core, of Transformer.*)

Core Pins of Magnet.—(See Appendix—*Pins, Core, of Magnet.*)

Cores, Krizik's — — Cores for magnetic solenoids shaped so as to insure an approximately uniform pull in different positions in the solenoid. (See *Bars, Krizik's.*)

Coreless Armature of Dynamo or Motor.—(See Appendix—*Armature, Coreless, of Dynamo or Motor.*)

Corona, Electrostatic — — A luminous effect produced on the surface of a thin sheet of mica, or other similar insulating material, when placed between two electrodes between which discharges of comparatively high difference of potential are passing.

Steinmetz describes the phenomena of the electrostatic aurora and corona in the *Electrical Engineer* for April 5, 1893, as follows :

“Very interesting luminous effects take place when a thin sheet of good insulating material, as mica; is placed between the electrodes. At a difference of potential of 830 volts and a thickness of mica of 1.8 millimetres, in darkness a faint bluish glow becomes visible between the mica and the electrodes. This glow is very perceptible at 970 volts, and faintly visible in broad daylight at 1,560 volts. With increasing difference of potential, this bluish glow increases in intensity, forming a sharply defined, smooth blue line around the electrodes at their point of contact with the mica.

“At a difference of potential of 4.5 kilovolts—thickness of mica of 2.3 millimetres—violet creepers of about two mm. length break here and there out of the line of bluish glow. These creepers are distinctly different from the blue glow surrounding the electrodes and increase in number and length with increasing potential, until they form a broad electrostatic aurora surrounding the electrodes on either surface of the mica sheet, consisting of an infinite number of small violet streamers, rushing with a hissing noise over the mica. This corona increases rapidly in width until it reaches the edges of the mica sheet. Then white sparks of intense brightness pass from electrode to electrode over the surface of the mica, first few in number, then with increasing potential, covering the whole sheet with an infinite number of streaks of lightning with a roaring noise. The amount of current passing through these sparks is exceedingly small, for no perceptible reaction upon the primary circuit was noticed. The length of these sparks is many times larger than the

sparkling distance in air, being tenfold at 17 kilovolts. They are intensely hot, and leave whitish marks, due to calcination, on the mica when passing over it. The sheet of mica, and especially the electrodes, become heated very rapidly, the mica twists and begins to splinter, to separate into sheets, until finally it breaks down.

“The width of the electrostatic corona is half the length of these sparks. The length of these sparks depends somewhat upon frequency and the thickness of the mica sheet, being greater for higher frequency and thinner mica disc, but apparently only in so far as the capacity, or rather the charging current of the condenser, represented by the mica disc as dielectric, is increased thereby.”

Corrosion, Electrolytic — — A term frequently employed for the corrosion of water or gas pipes or other masses of metal buried in the earth by electrolytic action.

In the case of such large currents as those employed in the electric railway car systems, or other similar earth-connected circuits, the corrosion may become marked. In such cases electrolytic corrosion is due to the return current.

The amount of corrosion varies according to whether the railroad tracks are made the positive or negative terminal of the driving source.

It is claimed by some that electrolytic corrosion is lessened by connecting the trolley line to the negative terminal of the battery and the tracks to the positive terminal.

Perrine describes this matter as follows :

“A more complete system of grounding seems, however, to offer at least a partial solution of this difficulty, which may only be completely worked out in a careful study of the special conditions in some particular case.

“For such a complete system of grounding, in order to reduce to a minimum electrolytic corrosion, the negative pole of the dynamo should be connected to the trolley and feeder line ; then at the station connections should be made not only with the rails.

and wells, but also with all water and gas pipes, which piping system should also be frequently connected to the track and track feeder, so that whatever current passes by the medium of these pipes should flow *out of* the earth *into* them, and thence to the rails by means of metallic and not electrolytic conduction. If this be completely accomplished there can be no corrosion of the pipes caused by the current flowing out of the pipes to the rails, and the only corrosion possible will be that due to the local action caused by the difference of potential along the pipes themselves."

It would appear that the total corrosion of pipes that are not in metallic connection with the circuit is independent of the polarity of the terminal, since the same amount of current which enters the pipe from the ground must leave it by again passing to ground. In this manner the area of entrance into the pipe is protected and its area of exit corroded electrolytically. By changing the terminals the protected and corroded parts are merely interchanged.

By making the shunt current passing through the pipes leave the pipes by means of a metallic conductor instead of by the ground, the entire system of pipes is brought below the potential of the ground and a protection or partial protection is thus effected.

Experiments made on the West End Railroad of Boston and elsewhere, appear to show that it makes but little difference which terminal is connected to earth. It is by many considered best to alternately connect the positive and negative terminals to earth for a period of a week at a time and not to depend on the earth for a return, or make use of a supplemental wire, but to double-bond the rails with heavy copper wire, placing the connections back $2\frac{1}{2}$ to 3 feet respectively from the end of the rails to avoid the motion of the joint. With a rail 70 pounds to the yard, on a four track road, this is equivalent to about 28 inches cross-section of steel, the carrying capacity of which is $4\frac{1}{4}$ square inches of copper. If, therefore, an equally good connection is made from the rails to the generator at the power station, there is thus provided a path capable of carrying

10,000 ampères without undue heating. Rails bonded in this manner and used as returns, will avoid the variable resistance of the earth arising from dry weather, poor contact with earth, frost, etc., and will consequently avoid electrolytic corrosion in neighboring pipes.

Cosine Law of Illumination.—(See Appendix—*Illumination, Cosine Law of.*)

Coulomb, International — — The value of the international coulomb adopted by the Chicago Congress of 1893, as equal to the quantity of electricity transferred by a current of one international ampère in one second.

Coulomb Meter.—(See Appendix—*Meter, Coulomb.*)

Coulomb's Electric Balance.—(See Appendix—*Balance, Coulomb's Electric.*)

Coulomb's Magnetic Torsion Balance.—(See Appendix—*Balance, Coulomb's Magnetic Torsion.*)

Counter, Electro-Chronometric — — An apparatus employed in a system of electrical clocks to so transmit the motion of an ordinary clock to a number of separate clocks as to control or operate them.

Electro-chronometric counters consist essentially of two parts, namely,

(1.) The indicator or apparatus connected with the regulating clock and operating to periodically make and break the current of a battery.

(2.) The mechanism that moves the clock hands when actuated by the current sent into the line by the indicator.

Counter-Electromotive Force of Electrolysis.—(See Appendix—*Electrolysis, Counter-Electromotive Force of.*)

Couple, Molecular Voltaic — — A voltaic couple formed of the atoms or radicals of a molecule.

Lermantoff has shown that during the development of the photographic image in moist collodion a true electrolysis occurs, each silver molecule produced by the action of the light on the sensitized plate forming a

voltaic couple with a molecule of silver nitrate and a molecule of iron sulphate of a developer.

Crater of Arc.—A crater formed in the end of the positive carbon electrode in a carbon voltaic arc. (See *Arc, Voltaic*.)

Creeping of Belt.—(See Appendix—*Belt, Creeping of*.)

Cross-Fire.—A term employed in telegraphy for an escape or leakage of current from one telegraphic line to another, due to defective insulation.

A cross-fire is sometimes called a weather cross. (See *Cross, Weather*.)

Cross-Induction of Dynamo Armature.—(See Appendix—*Induction, Cross, of Dynamo Armature*.)

Cross, Metallic — —A form of fault attended by a leakage or escape of current from a telegraphic line due to the absolute contact between two or more wires or conductors, so that part of the current from one line passes to the other.

Cross-Over, Trolley — —In a system of electric street railways a device permitting the ready passage of a trolley wheel in a continuous direction from one to another of two adjacent wires.

Cross, Peltier's — —A cross made by placing two plates of dissimilar metals in contact at right angles to each other, and employed for the study of the Peltier effect. (See *Effect, Peltier*.)

Crossing Frog.—A term sometimes employed in place of trolley cross-over.

Crystal, Pyro-Electric — —Any crystalline substance capable of producing pyro-electric phenomena on being unequally heated.

Tourmaline, electric calamine, boracite, quartz, tartrate of potash, and sulphate of quinine are examples of pyro-electric crystals.

Cubic Energy.—(See Appendix—*Energy, Cubic*.)

Cup Brush.—(See Appendix—*Brush, Cup*.)

Current Accumulator.—(See Appendix—*Accumulator, Current*.)

Current, Arriving, of Telegraphic Circuit — —A term employed to designate the current on a telegraphic line or conductor near the distant end of the wire close to where it enters the ground or earth.

Current, Axial — —A term proposed for a current whose direction coincides with the direction of the lines of magnetic force.

This use of the term axial current is in contradistinction to a radial current, or one whose direction is at right angles to the direction of the lines of magnetic force.

The term axial current is employed in electro-therapeutics in a different sense to the above. (See *Current, Axial*.)

Current, Beginning of — —A term sometimes employed for the making or closing of the current in any circuit.

Current, Bony — —A term proposed by Becquerel for the electric current resulting from the difference of potential existing between two different parts of a bone of a recently killed animal.

If a bone be taken from a recently killed animal and the marrow connected by means of metallic terminals with the surface of the bone, an electric current will flow through the circuit, for which Becquerel proposed the name bony current.

This term is not generally adopted.

Current, Cessation of — —A term sometimes employed for the breaking of the current in any circuit.

Current, Demagnetizing — —A current whose magnetic field is employed to decrease the strength of an already existing magnetic field by directing its lines of force oppositely to that of the existing field.

Current, Effective — —A term proposed by Ayrton, but not accepted, for the current producing a given effect.

This term, Ayrton thinks, is an unfortunate one, since the effective current will of course depend on the character of the effect the current is desired to produce.

If, however, the word "effect" be understood to mean "power," then the vagueness ceases, and, since the power is proportional to the square of the current, the effective current is the square root of the mean squares, but all the effects produced by an alternating current are proportional to the square root of the mean squares.

The ordinary meaning of effective current is that given it by the definition of the Electrical Congress of Paris, in 1889, viz., the square root of the time average of the square of the current.

An alternating or periodically varying current has an "effective" strength such that if this effective strength were steadily maintained in the same direction through a given resistance it would generate as much heat in a given length of time as the periodical current.

When electrolysis or the magnetization of iron is the effect produced, the effective current is identical with the mean current. Where a heating or dynamometric effect is to be produced, the effective current is equal to the square root of the mean square of the current.

Current, Effective Starting, of Motor

— — The indicated value of the starting current of a motor as observed on an ammeter.

Current Efficiency of Secondary Battery.

—(See Appendix—*Battery, Secondary, Current Efficiency of.*)

Current, Entering, of Telegraphic Circuit — —A term employed to designate the current on a telegraphic line or conductor near the battery.

Current, Harmonics of — — A term sometimes used for the upper harmonics of

a current. (See Appendix—*Current, Upper Harmonics of.*)

Current, M. — —A term proposed by Ayrton for mean current.

This term, M. current, is employed to signify the average value with respect to time, and is obtained by dividing the total quantity of electricity which passes through a given circuit in a given number of seconds by the number of seconds. It has not been generally accepted.

Current, M. S. — —A term proposed by Ayrton for mean square current.

This term was proposed in order to avoid the use of the alleged vague term, effective current. It applies to cases where the effective current has a value equal to the mean square of the current. It has not been generally accepted.

Current, Maximum Starting, of Motor

— — The highest value that the starting current of a motor attains.

Current of Charge on Telegraphic Line.

—(See Appendix—*Line, Telegraphic, Charge Current on.*)

Current, Polyphase — —A term now generally employed in place of multiphase current. (See *Current, Multiphase.*)

Current, Polyphase Alternating, Proposed A. I. E. E. Definition for — —A combination of more than two alternating currents differing in phase.

Current, R. M. S. — —A term proposed by Ayrton for the square root of the mean square of the current.

This term was proposed in order to avoid the use of the alleged vague term, effective current. It applies to cases where the effective current has a value equal to the square root of the mean square of the current. It has not been generally accepted.

Current, Radial — —A term proposed for a current whose direction is at right angles to the direction of the lines of magnetic force.

This use of the word radial current is in contradistinction to the word axial current, whose direction coincides with that of the lines of magnetic force. (See Appendix—*Current, Axial.*)

Current, Simple or Two-Phase Alternating — — Two alternating currents whose phases differ by 90° or by 270° .

Current, Sinusoidal — — A term sometimes employed for sinuous current. (See *Current, Sinuous.*)

A simple-harmonic current in respect to time.

A current whose strengths graphically set forth as ordinates as time to abscissas follow a sinusoidal curve.

Current, Starting, of Motor — — The current which a motor requires in order to start from a state of rest.

Current Transformation.—(See Appendix—*Transformation, Current.*)

Current, Triphase — — A term sometimes employed in place of three-phase current. (See Appendix—*Currents, Three-Phase.*)

Current, Triphase Alternating, Proposed A. I. E. E. Definition for — — Three alternating currents whose phases differ by 60° or 120° .

Current, Tubular — — A term sometimes applied to a current that traverses the superficial portions only of a conductor.

When a rapidly intermittent current is sent through a solid conductor, the current density is greater at the surface of the conductor than in the central portions, and, when the rapidity of alternation becomes very great, is confined to an exceedingly thin outer layer.

A tubular current possesses no magnetizing power on anything placed inside the tube.

Current, Upper Harmonics of — — A series of higher harmonic currents of greater frequency than the fundamental current impressed on a simple-harmonic

current by any means. (See Appendix—*Currents, Complex-Harmonic.*)

Current, Virtual — — A somewhat vague term sometimes employed for a current virtually equivalent to something else.

A term employed for the square root of the mean square of the current strength.

Current, Working, of Motor — — The current required to maintain a motor when its load is on.

Currents, Complex-Harmonic — — Currents which result from the superposition of several simple-harmonic currents. (See *Current, Simple-Harmonic.*)

Currents resulting from the co-existence of the higher harmonic currents with the fundamental harmonic current.

Unless certain precautions are taken the currents produced in the secondary circuit of a transformer or induction coil are by no means simple-harmonic currents. It is true, of course, that the fundamental frequency has the same frequency as that of the currents sent through the primary circuit, but the currents so induced in the secondary, however, are complex-harmonic currents, their frequency depending, according to Pupin: "On the fundamental frequency of the ohmic resistance, and especially on the self-induction and electrostatic capacity of the primary or secondary circuits."

Complex-harmonic currents of the secondary of induction coils possess a fundamental frequency the same as the frequency of the currents impressed on the primary, but they have associated with them a number of higher harmonic currents, which correspond to the overtones of a musical note.

These overtones are due to rapid electrical oscillations accompanying the spark discharges. The association of these higher harmonic currents with the fundamental harmonic current produces what are called complex-harmonic currents.

Complex-harmonic currents always exist when there is iron in a circuit, especially if the iron is highly magnetized, when they are due to the fact that the magnetization pro-

duced is not proportional to the magnetizing force.

It is only in circuits of constant resistance, containing no iron, that the current produced by a simple harmonic or sine wave of E. M. F. is a sine wave. Magnetic hysteresis, or a periodically varying resistance as by an electric arc, causes a distortion of the current and a consequent superposition of higher harmonics on the fundamental wave. Consequently the primary currents of transformers at open secondary circuit or very light load are complex harmonics, and approach more nearly to true sine shapes at increasing loads. When, however, the secondary E. M. Fs. of a transformer are simply harmonics, the secondary currents are also simply harmonics, in circuits without iron cored coils.

Currents produced by complex-harmonic E. M. F. are also complex harmonic; generally, however, the higher complex harmonics of the E. M. F. wave are larger than the complex harmonics of the current wave.

Currents, Mutually-Induced — — Currents set up or produced by means of mutual induction. (See *Induction, Mutual*.)

Currents, Polyphase — — Currents differing in phase from one another and, therefore, requiring separate circuits for use.

The currents may differ from one another by one-half phase, by one-third of a phase, a quarter phase and so on, when they are respectively called di-phase or two-phase currents, triphase or three-phase currents, and four-phase currents. An ordinary alternating current is called a single-phase or uni-phase current. The latter term is the preferable one.

The term polyphase currents is applied to all currents over three-phase, though sometimes also to all currents over two-phase.

Currents, Polyphased, Alternating — — Two or more alternating currents differing in phases from each other.

Currents, Skin — — A term some-

times applied to the currents that are limited to the surface of a solid conductor.

Rapidly alternating currents are limited to the surface of solid conductors since before any such currents have time to penetrate towards the centre of a solid conductor their direction is reversed, thus limiting them to the surface portions.

Currents, Three-Phase — — Triphased currents. (See Appendix—*Currents, Triphased, Alternating*.)

Currents, Triphased, Alternating — — Three alternating currents differing 120° in phase from each other.

In the two-phase system two currents differing in phase 90° have a common return wire whose area should be $\sqrt{2}$ greater than either leading wire.

In the three-phase system each of three currents differing in phase 120° uses alternately one or two of the three wires for a return.

Curve, Arrival, of Telegraph Circuit — — A curve of ordinates and abscissas which represent respectively the times and the gradual increase of current at the receiving end of a telegraph circuit from the time the circuit is closed until the time the current has reached its full strength.

Curve, Clown's Hat — — A term proposed for the curve of a current or electromotive force in which the pressure generated increases or decreases at a maximum rate of change.

The name is taken from the shape of the curve being somewhat similar to the shape of a peaked or clown's hat.

Curve, Top-Hat — — A term proposed for the current or E. M. F. in which the pressure generated is fairly constant for a considerable time at its maximum rise and fall.

The name is taken from the shape of the curve being somewhat similar to that of a top-hat, or flat crowned hat. A current for the primary of a transformer or induction

coil, however, of the top-hat type, makes a bad form of secondary current curve, for in such a curve the rate of change, whether increasing or decreasing, would be small. The current whose curve of electromotive force is sharp and peaked like a clown's hat would, of course, be preferable.

Cut-In, A — —A term sometimes employed in place of film cut-out.

An automatic-guard cut-out. (See *Cut-Out, Film.*) (See Appendix—*Guard, Automatic, for Series-Connected Incandescent Lamps.*)

Cut-Out, D. P. — —A contraction for double-pole cut-out. (See Appendix—*Cut-Out, Double-Pole.*)

Cut-Out, Double-Pole — —A cut-out which provides in one operation the cutting out of both the positive and the negative leads.

Cut-Out, Electro-Magnetic — —A term sometimes employed for a cut-out operated by means of an electro-magnet. (See *Cut-Out, Automatic, for Series-Connected Electro-Receptive Devices.*)

A form of electro-magnetic cut-out is used

in charging accumulators and sometimes in street railway circuits.

Cut-Out, S. P. — —A contraction for single-pole cut-out. (See Appendix—*Cut-Out, Single-Pole.*)

Cut-Out, Single-Pole — —A cut-out by means of which the circuit is broken or cut in one of the two leads only.

Cut-Out, Wedge — —A form of cut-out employed on telegraphic circuits.

The ends of the instrument wire are connected to the opposite sides of a wedge formed of two brass plates suitably insulated from one another. The ends of the line wire or conductor are suitably connected to two metallic pieces that are maintained in electrical contact by means of a spring electrically connected to one of the pieces and caused to bear with elastic pressure against the other piece. In order to introduce an instrument into the line circuit, a switch-wedge, or plug, is inserted between the two pieces, and, thus separating them, opens the circuit of the line wire or conductor, and at the same time connects it with the instrument thus introduced.

Cyclic.—Of or pertaining to a cycle. (See *Cycle.*)

D

D. B. Switch.—(See Appendix—*Switch, D. B.*)

D. P. Cut-Out.—(See Appendix—*Cut-Out, D. P.*)

D. P. Switch.—(See Appendix—*Switch, D. P.*)

Damping Magnet.—(See *Magnet, Damping.*)

Dark Discharge.—(See Appendix—*Discharge, Dark.*)

Dark Segment of Aurora.—(See Appendix—*Segment, Dark, of Aurora.*)

Dead Ground.—(See Appendix—*Ground, Dead.*)

Declination Compass.—(See Appendix—*Compass, Declination.*)

Decomposition, Electro-Chemical — —A term often employed for electrolytic decomposition. (See *Electrolysis.*)

Decomposition, Molecular — —The separation or breaking up of a molecule into its constituent atoms or radicals.

Molecular decomposition may be effected in the following ways, namely:

- (1) By electrolysis, or the action of an electric current.
- (2) By thermolysis, or the action of heat.
- (3) By actinism, or the action of light.

(4) By chemism, or the action of superior chemical affinity.

(5) By pressure.

Deflecting Magnet.—(See Appendix—*Magnet, Deflecting.*)

Degree, Water-Gramme — —The amount of heat required to raise the temperature of one gramme of water at 4° C., the temperature of its maximum density, one degree centigrade.

A small calorie. (See *Calorie, Small.*)

Delta Triphase System.—(See Appendix—*System, Delta Triphase.*)

Demagnetizing Current.—(See Appendix—*Current, Demagnetizing.*)

Depolarizer.—The material employed in a voltaic cell for the purpose of depolarizing it. (See *Cell, Voltaic, Polarization of.*)

In most cases the depolarizer is a different liquid and is kept separate from the exciting liquid or electrolyte. In some cases, however, the depolarizer is mixed with the exciting liquid.

Deposit, Electro-Metallurgical Burnt — —A term sometimes applied to a black deposit of metal which is thrown down when the intensity of the depositing current is too strong. (See *Deposit, Electro-Metallurgical.*)

Deviation, Quadrantal, of Mariner's Compass — —The deviation of the magnetic needle due to the induced magnetism in the iron of a ship acting as a mass of soft iron, and not as a permanent magnet.

Quadrantal deviation changes sign and passes through successive opposite maxima four times in one complete revolution of the ship.

Quadrantal deviation is corrected by placing masses of soft iron, usually spherical in shape, in suitable positions on each side of the compass.

Deviation, Semi-Circular, of Mariner's Compass — —The deviation of a magnetic needle due to the permanent mag-

netism in the iron of a ship having its resultant in the horizontal plane.

Semi-circular deviation passes through two opposite maxima and two zero points as the ship completes a revolution, and these zero points of deviation occur when the resultant magnetic axis of the ship coincides with the magnetic meridian.

Semi-circular deviation is corrected by fastening a permanent magnet in the proper position near the compass to neutralize the influence of the ship's iron.

Diagram, Load — — A diagram or curve representing to scale the load or activity of a plant at different times.

Dial, Induced Single-Needle — —A dial employed in single-needle telegraphy in which both the needle and its axle are formed of soft iron and have magnetism induced in them by means of permanent horseshoe magnets placed so as to act magnetically on the needle.

The object of the induced single-needle telegraphic dial is for the purpose of avoiding the weakening of the magnetism of the needle, or its total loss or reversal, by various means, such, for example, as a discharge of lightning, the effect of earth currents, etc.

Dial Telegraph.—(See Appendix—*Telegraph, Dial.*)

Dialyzing.—Subjecting to the process of dialysis. (See *Dialysis.*)

Diamagnetized. — Endowed with diamagnetic properties. (See *Diamagnetism.*)

Diamond Drill.—(See Appendix—*Drill, Electric, Diamond.*)

Dielectric, After-Working of — —A term sometimes employed for a residual charge. (See *Charge, Residual.*)

The term after-working of a dielectric was proposed by Boltzmann. It is not much used in the United States.

Dielectric, Breaking-Down of — — Such a weakening of a dielectric that permits a disruptive discharge to pass through

its substance. (See Appendix—*Dielectric, Disruptive Strength of*.)

Dielectric, Disruptive Strength of —
—The resistance which an insulating medium or dielectric offers to the disruptive passage of an electric discharge through it.

According to Steinmetz the disruptive strength of different materials shows no relation to their electric resistance.

Dielectric Hysteresis.—(See Appendix—*Hysteresis, Dielectric*.)

Difference of Tension.—(See Appendix—*Tension, Difference of*.)

Differential Coils.—(See Appendix—*Coils, Differential*.)

Differential Electro-Dynamometer.—(See Appendix—*Dynamometer, Electro, Differential*.)

Differential Electro-Magnet.—(See Appendix—*Magnet, Differential, Electro*.)

Differential Winding.—(See Appendix—*Winding, Differential*.)

Diffusing Globes for Electric Lights.—
(See Appendix—*Globes, Diffusing, for Electric Lights*.)

Di-Phase Armature.—(See Appendix—*Armature, Di-Phase*.)

Di-Phase Generator.—(See Appendix—*Generator, Di Phase*.)

Di-Phase Motor.—(See Appendix—*Motor, Di-Phase*.)

Diplex Telegraph.—(See Appendix—*Telegraph, Diplex*.)

Dip of Line Wire or Conductor.—(See Appendix—*Conductor or Line Wire, Dip of*.)

Dipping Basket.—(See Appendix—*Basket, Dipping*.)

Dipping Hook.—(See Appendix—*Hook, Dipping*.)

Dips.—Acid solutions employed in electro-plating in which articles that are to be plated are cleansed by dipping.

Direct-Current Dynamo-Electric Machine.—(See Appendix—*Machine, Dynamo-Electric, Direct-Current*.)

Direct-Current Exciter.—(See Appendix—*Exciter, Direct-Current*.)

Direct-Current Rotary Transformer.—
(See Appendix—*Transformer, Direct-Current Rotary*.)

Direct Reading Galvanometer.—(See Appendix—*Galvanometer, Direct Reading*.)

Direct Working of Telegraphic Sounder.—
(See Appendix—*Working, Direct, of Telegraphic Sounder*.)

Directed - Streaming Discharge.—(See Appendix—*Discharge, Directed-Streaming*.)

Directing Clock.—(See Appendix—*Clock, Directing*.)

Disc, Retarding — —A copper disc supported on a rotating shaft, and so placed as to cut the lines of force from a magnet for the purpose of retarding the speed of rotation.

In Elihu Thomson's recording electric meter a copper disc, moving in the field of a permanent magnet, is so retarded that the resulting number of revolutions is directly proportional to the energy to be measured.

Discharge, Dark — —A term applied by Faraday to that portion of a convective discharge, separating the positive from the negative electrode, that occurs under certain circumstances through a rarefied gas.

Discharge, Directed-Streaming — —
A Tesla discharge which assumes the shape of a hollow luminous cone.

The discharge takes place between a sphere or ball S (Fig. 570), and a ring-shaped electrode.

W, thereby producing a hollow luminous cone such as is shown in the figure.

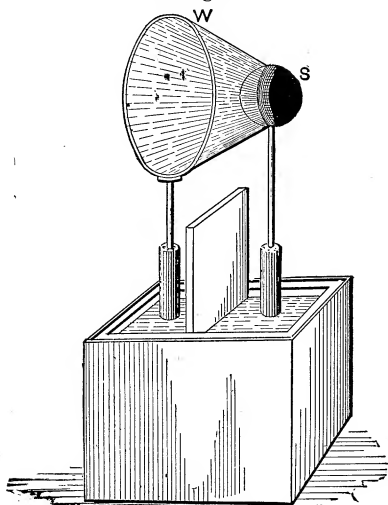

Fig. 570. Directed-Streaming Discharge.

Discharge, Luminous Disc-Shaped — — A name given to a variety of Tesla discharge that occurs between ring-shaped terminals.

The terminals are arranged as shown in Fig. 571. On the passage of the current a luminous

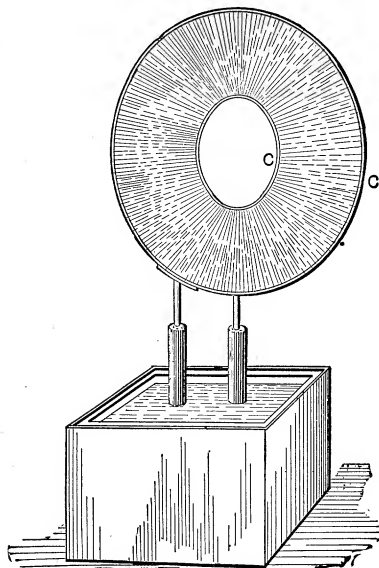

Fig. 571. Luminous Disc-Shaped Discharge. disc-shaped discharge occurs between the ring-

shaped terminals C, C, which presents the appearance shown in the figure.

Discharge, Slow, Method of — — An insulation test for a well-insulated telegraphic line, by the observation of the rate at which a charge leaks out when the conductor is left insulated.

A well-insulated cable will take, say, half an hour to fall to half charge, and, with uniform cables, this time is independent of their length.

Discharge, Spark — — An electric discharge effected by means of a spark.

A disruptive discharge. (See *Discharge, Disruptive*.)

Discharge, Tesla — — An exceedingly high frequency discharge.

The Tesla discharge is so named after its discoverer, Nikola Tesla.

Dish, Chafing, Electric — — An electrically heated chafing dish.

An electric heater is applied to an ordinary chafing dish, so as to permit the electrical heating to take the place of ordinary heating.

A form of electrically heated chafing dish is shown in Fig. 572, and will be readily understood from inspection. (See *Heater, Electric*.)

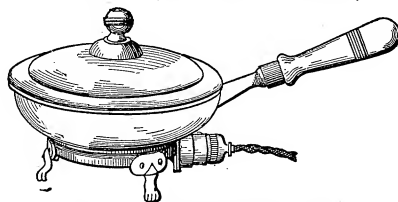

Fig. 572. Electric Chafing Dish.

Disruptive Strength of Dielectric.—(See Appendix—*Dielectric, Disruptive Strength of*.)

Dissonance, Electric — — Electric disagreement.

Two alternating currents are in electric dissonance when their periods are different. The term electric dissonance is employed in contradistinction to electric consonance.

Distance, Striking — — The distance through which a disruptive discharge will pass. (See *Discharge, Disruptive*.)

Distance, Striking, for Various Substances — — Tables of Steinmetz give the following values for the striking distances of various mediums under certain circumstances.

δ IN MILLI-CENTIMETRES, V IN KILO-VOLTS.

Air.....	$\delta = 36 \left(e^{-1.3 V} - 1 \right) + 54 V + 1.2 V^2 \dots$.18	$\leq V \leq$	24.0
Mica	$\delta = .24 V + .0145 V^2 \dots$.8	$\leq V \leq$	20.3
Vulcanized Fibre	$\delta = 7.66 V + 2.3 V^2 \dots$	2.2	$\leq V \leq$	22.5
Dry Wood Fibre	$\delta = 7.66 V \dots$	2.8	$\leq V \leq$	21.6
Paraffined Paper	$\delta = 3 V \dots$	6.9	$\leq V \leq$	24.8
Melted Paraffin, 65° C.....	$\delta = 12.4 V \dots$	3.9	$\leq V \leq$	27.1
Boiled Linseed Oil, 21° C.....	$\delta = 12.5 V \dots$	7.6	$\leq V \leq$	21.3
Turpentine Oil	$\delta = 15.7 V \dots$	7.1	$\leq V \leq$	15.6
Copal Varnish.....	$\delta = 30 V \dots$	9.7	$\leq V \leq$	20.4
Crude Lubricating Oil	$\delta = 60 V \dots$	4.4	$\leq V \leq$	15.9
Vulcabeston	$\delta = 28 V \dots$	4.0	$\leq V \leq$	12.6
Asbestos Paper	$\delta = 23 V \dots$	2.7	$\leq V \leq$	5.0
Creeping discharge over surface of Mica.....	$\delta = 55 (V - 2)^2 \dots$	4.5	$\leq V \leq$	17.1

In the above table δ equals the thickness of the dielectric in milli-centimetres, or thousandths of a cm.; e equals the Napierian base, and V equals the potential difference in kilo-volts.

The last column gives the lowest and highest values of V in the experiments on the different materials.

The following table gives the data concerning a disruptive discharge through air:

TABLE I.—DISRUPTIVE DISCHARGE THROUGH AIR.

$$\delta = 36 \left(e^{-1.3 V} - 1 \right) + 54 V + 1.2 V^2$$

Maximum Difference of Potential in Kilo-Volts.	Sparking Distance observed in Milli-centimetres.	Electrostatic Gradient, in Kilo-Volts per cm.	Sparking Distance calculated in Milli-centimetres.	Difference. $\delta - \delta$ calc. obs.	Difference in per cent. of δ calc.
V	δ obs.	g	δ calc.	Δ	%
.18	3.0	60	2.2	-.8	(-36)
.26	4.6	57	3.8	-.8	(-21)
.29	5.1	57	4.5	-.8	-13.3
.46	8.1	57	8.9	+.8	+9.0
.48	9.1	53	9.5	+.4	+4.2
.53	11	48	11.0	0	
.71	16	44	17.1	+1.1	+6.4
1.43	48	30	49.3	+1.3	+2.6
1.76	68	26	66.4	-1.6	-2.4
2.46	100	25	105.7	+5.7	+5.4
3.96	190	21	197	+7	+3.5
5.5	287	19	297	+10	+3.4
9.5	575	17	584	+9	+1.6
12.7	860	15	844	-16	-1.9
15.7	1150	14	1110	-40	-3.6
19.6	1440	14	1480	+40	+2.7
22.6	1730	13	1800	+70	+3.9
24.0	2010	12	1950	-60	-3.1
Averages.....				±14.7	±4.2

Distant Battery.—(See Appendix—*Battery, Distant.*)

Distortion of Magnetic Field.—(See Appendix—*Field, Magnetic, Distortion of.*)

Distributing Board.—(See Appendix—*Board, Distributing.*)

Distributing Brushes of Electric Motor.—(See Appendix—*Brushes, Distributing, of Electric Motor.*)

Distributing Switch Board.—(See Appendix—*Board, Distributing Switch.*)

Distribution of Complex Lamellar Magnetism.—(See Appendix—*Magnetism, Complex Lamellar, Distribution of.*)

Disturbance, Magnetic — —A term sometimes employed for the temporary variations in the intensity of the earth's magnetism caused by a magnetic storm.

Divided Touch.—(See Appendix—*Touch, Divided.*)

Door Trigger.—(See Appendix—*Trigger, Door.*)

Dot-and-Dash Code.—(See Appendix—*Code, Dot-and-Dash.*)

Double Block, Duplex.—(See Appendix—*Block, Double Duplex.*)

Double-Bronze Wire.—(See Appendix—*Wire, Double-Bronze.*)

Double-Contact Push.—(See Appendix—*Push, Double-Contact.*)

Double-Contact Push Button.—(See Appendix—*Button, Push, Double-Contact.*)

Double-Current Telegraphic Working.—(See Appendix—*Working, Double-Current Telegraphic.*)

Double-Curve Pull-Off.—(See Appendix—*Pull-Off, Double-Curve.*)

Double-Curve Trolley Hanger.—(See *Hanger, Double-Curve Trolley.*)

Double Liquid Voltaic Cell.—(See *Cell, Voltaic, Double Liquid.*)

Double-Pole Cut-Out.—(See Appendix—*Cut-Out, Double-Pole.*)

Double-Wire System for Electric Light Leads.—(See Appendix—*Leads, Double-Wire System for Electric Light.*)

Drifting of Zero Point.—A term frequently employed in place of shifting of zero point. (See Appendix—*Shifting of Spot of Light.*)

Drift of Needle.—(See Appendix—*Needle, Drift of.*)

Drill, Electric Diamond — —A diamond drill driven by electric power.

Drill, Electro-Percussion — —A drill for quarrying or mining purposes, in which the reciprocating motion is obtained by sending alternately a current through a pair of solenoids of which the drill stock forms the core.

Drill, Electro-Reciprocating — —An electro-percussion drill. (See Appendix—*Drill, Electro-Percussion.*)

Drop Relay-Contact.—(See Appendix—*Contact, Drop-Relay.*)

Drop Trolley.—(See *Trolley, Drop.*)

Dry Battery.—(See Appendix—*Battery, Dry.*)

Dry Gelatine Cell.—(See Appendix—*Cell, Dry Gelatine.*)

Duplex Balance.—(See Appendix—*Balance, Duplex.*)

Duplex Telegraph.—(See Appendix—*Telegraph, Duplex.*)

Duplex Telephony.—(See Appendix—*Telephony, Duplex.*)

Dust, Electrical Aggregation of, in Dust-Laden Air — —A coalescence of a great number of separate particles of dust, in dust-laden air, by means of the action of an electrical brush discharge.

If a brush or convection discharge be passed through dust or smoke-laden air, contained for purposes of observation in a glass globe, the electrical aggregation of the particles of dust or smoke rapidly clears the air. This method is practically employed in the manufacture of lamp-black.

Dyad Atom.—(See Appendix—*Atom, Dyad.*)

Dynamic Multiplier.—(See Appendix—*Multiplier, Dynamic.*)

Dynamics.—That branch of mechanics

which treats of the action of a force in producing motions or pressures.

Dynamo-Electric Machine for Electro-Plating.—(See Appendix—*Machine, Dynamo-Electric, for Electro-Plating.*)

Dynamo, Idle Wire of — —(See Appendix—*Wire, Idle, of Armature of Dynamo.*)

Dynamometer, Electro, Differential — —A double dynamometer with the moving coils rigidly connected and oppositely influenced, so that the movement of the suspension system can be reduced to zero by electrical adjustments when the instrument is under operation.

Dynamo, Motor — —(See Appendix—*Motor, Dynamo.*)

Dynamo or Motor Frame.—(See Appendix—*Frame, Dynamo or Motor.*)

Dynamo Standards.—(See Appendix—*Standards, Dynamo.*)

Dynamos Coupled in Potential Series.—(See Appendix—*Series, Potential, Dynamos Coupled in.*)

Dynamotor.—A continuous current transformer.

A term now generally employed for motor-generator. (See *Generator, Motor.*)

A motor-dynamo, or motor-generator, is practically a dynamo driven by means of an electric current. The motor-dynamo consists of two distinct or separate armatures placed on the same shaft, or two separate armature windings placed on the same core. On sending the current through one armature or winding it acts as a motor and turns the shaft, thus producing current in the other armature or winding. Such a machine is sometimes called a rotary transformer, though this name is preferably limited to a machine containing only a single armature, which acts as a generator and motor armature. (See *Transformer, Constant Current.*)

Such a machine is employed for transforming continuous currents into continuous currents of different potential, or for transforming alternating or polyphase currents into continuous currents, or *vice versa*.

Dyne : cm.—An abbreviation proposed for dyne-centimetre, the C. G. S. unit of moment of couple.

Dyne : cm².—An abbreviation proposed for dyne per square centimetre, the C. G. S. unit of pressure.

E

E.—A symbol proposed for electromotive force.

The defining equation is $E = RC$.

e.—A symbol proposed for difference of potential.

The defining equation is $e = rC$.

E. H. P.—A contraction for electrical horsepower.

Earth, Bad — —A term sometimes employed for a ground or connection to earth, the electric resistance of which is comparatively high. (See *Earth or Ground.*)

Earth Cell.—(See Appendix—*Cell, Earth.*)

Earth, Good — —A term sometimes employed for a ground or connection to earth,

the electric resistance of which is comparatively low. (See *Earth or Ground.*)

Earthed.—Connected to ground or earth.

Easement.—A permit, obtained from the owner of a property, for the erection of poles or attachments for telephonic, telegraphic or other electric lines.

Effect, Page — —The faint sounds produced when a piece of iron is rapidly magnetized and demagnetized.

A faint click is produced when a bar of iron is magnetized or demagnetized. When, therefore, such a bar undergoes rapid magnetization and demagnetization these separate sounds link themselves into a continuous musical note, thus producing what is known as the Page effect. In the

larger masses of iron employed in transformer cores and alternator armatures, the Page effect sometimes rises to a loud humming noise.

Effects of Temperature on the Electric Resistance of Metals.—(See Appendix—*Resistance, Electric, of Metals, Effect of Temperature on.*)

Effective Current.—(See Appendix—*Current, Effective.*)

Effective Starting Current of Motor.—(See Appendix—*Current, Effective Starting, of Motor.*)

Efficiency of Electric Lamp.—(See Appendix—*Lamp, Electric, Efficiency of.*)

Efficiency of Electric Motor.—(See Appendix—*Motor, Efficiency of Electric.*)

Efficiency of Radiation.—(See Appendix—*Radiation, Efficiency of.*)

Efficiency of Secondary Battery.—(See Appendix—*Battery, Secondary, Efficiency of.*)

Effluvia, Electric — —A term employed in the early history of electricity for supposed effluvia proceeding from an electrified body and causing electrical phenomena.

Effluvia, Magnetic — —A term employed in the early history of magnetism for assumed, imponderable effluvia which were supposed to be given off by magnets.

The doctrine of magnetic effluvia may be regarded as a forerunner of the doctrine of lines of magnetic force introduced into science by Faraday.

In some of his earlier writings Boyle framed the hypothesis of a magnetic atmosphere, or region surrounding a magnet. He conceived the idea that magnetic effluvia, emitted from one of the poles of the magnet, passed through the space surrounding the magnet and re-entered it at its other pole. As will be seen, this conception closely resembles the modern conception concerning the flow of lines of magnetic force, or of magnetic flux.

Egg, Electric — —A term formerly employed for an egg-shaped vessel containing a partial vacuum through which an electric discharge is passed for the purpose of obtaining luminous effects.

Elastance.—A word proposed for the reciprocal of permittance. (See Appendix—*Permittance.*)

Elasticity.—The elastance of a dielectric referred to unit volume.

If the dielectric possesses great permittance it has of course but little elastance.

Electric Amalgamator.—(See Appendix—*Amalgamator, Electric.*)

Electric Anæsthesia.—(See Appendix—*Anæsthesia, Electric.*)

Electric Anemograph.—(See Appendix—*Anemograph, Electric.*)

Electric Atmosphere.—(See Appendix—*Atmosphere, Electric.*)

Electric Aura.—(See Appendix—*Aura, Electric.*)

Electric Broiler.—(See Appendix—*Broiler, Electric.*)

Electric Casting.—(See Appendix—*Casting, Electric.*)

Electric Chafing-Dish.—(See Appendix—*Dish, Chafing, Electric.*)

Electric Chronometer.—(See Appendix—*Chronometer, Electric.*)

Electric Clamp Attachment.—(See Appendix—*Attachment, Electric Clamp.*)

Electric Coil Heater.—(See Appendix—*Heater, Coil, Electric.*)

Electric Conflict.—(See Appendix—*Conflict, Electric.*)

Electric Deck-Planer.—(See Appendix—*Planer, Electric Deck.*)

Electric Dissonance.—(See Appendix—*Dissonance, Electric.*)

Electric Door-Trip.—(See Appendix—*Trip, Door, Electric.*)

Electric Effluvia.—(See Appendix—*Effluvia, Electric.*)

Electric Egg.—(See Appendix—*Egg, Electric.*)

Electric Escapement.—(See Appendix—*Escapement, Electric.*)

Electric Excitation.—(See Appendix—*Excitation, Electric.*)

Electric Flat-Iron.—(See Appendix—*Flat-Iron, Electric.*)

Electric Fluid.—(See Appendix—*Fluid, Electric.*)

Electric Forge.—(See Appendix—*Forge, Electric.*)

Electric Glue-Pot.—(See Appendix—*Glue-Pot, Electric.*)

Electric Gnomon.—(See Appendix—*Gnomon, Electric.*)

Electric Harpoon.—(See Appendix—*Harpoon, Electric.*)

Electric Horology.—(See Appendix—*Horology, Electric.*)

Electric Hummer.—(See Appendix—*Hummer, Electric.*)

Electric-Light Bath.—(See Appendix—*Bath, Electric-Light.*)

Electric Machine Tool.—(See Appendix—*Tool, Electric Machine.*)

Electric Matter.—(See Appendix—*Matter, Electric.*)

Electric Meteorograph.—(See Appendix—*Meteorograph, Electric.*)

Electric Meteorology.—(See Appendix—*Meteorology, Electric.*)

Electric Mining.—(See Appendix—*Mining, Electric.*)

Electric Pendulum.—(See Appendix—*Pendulum, Electric.*)

Electric Photo-Micography.—(See Appendix—*Photo-Micography, Electric.*)

Electric Pocket Gauge.—(See Appendix—*Gauge, Electric Pocket.*)

Electric Pressure.—(See Appendix—*Pressure, Electric.*)

Electric Radiation.—(See Appendix—*Radiation, Electric.*)

Electric Radiator.—(See Appendix—*Radiator, Electric.*)

Electric Rail Bond.—(See Appendix—*Bond, Electric Rail.*)

Electric Residue.—(See Appendix—*Residue, Electric.*)

Electric Spark.—(See Appendix—*Spark, Electric.*)

Electric Stopper Lamp.—(See Appendix—*Lamp, Electric Stopper.*)

Electric Stove-Plate.—(See Appendix—*Stove-Plate, Electric.*)

Electric Telegraph.—(See Appendix—*Telegraph, Electric.*)

Electric Tourniquet.—(See Appendix—*Tourniquet, Electric.*)

Electric Wand.—(See Appendix—*Wand, Electric.*)

Electric Windmill.—(See Appendix—*Windmill, Electric.*)

Electrical Aggregation of Dust in Dust-Laden Air.—(See Appendix—*Dust, Electrical Aggregation of, in Dust-Laden Air.*)

Electrical Aggregation of Raindrops.—(See Appendix—*Raindrops, Electrical Aggregation of.*)

Electrical Baking Oven.—(See Appendix—*Oven, Baking, Electrical.*)

Electrical Bombardment Lamp.—(See Appendix—*Lamp, Bombardment, Electrical.*)

Electrical Coking.—(See Appendix—*Coking, Electrical.*)

Electrical Equivalent of Heat.—(See Appendix—*Heat, Electrical Equivalent of.*)

Electrical Harmonics.—(See Appendix—*Harmonics, Electrical.*)

Electrical Stimulus of Nerve.—(See Appendix—*Stimulus, Electrical, of Nerve.*)

Electrically Illumined Buoy.—(See Appendix—*Buoy, Electrically Illumined.*)

Electrically Tuned System.—(See Appendix—*System, Electrically Tuned.*)

Electricity, Reversible Heating Effect of — A term sometimes employed in place of the Peltier effect. (See *Effect, Peltier.*)

An effect of this character is called reversible, because when the current is passed across an electro-thermal junction in one direction, heat is produced, while if it is passed in the opposite direction, cold is produced.

Electricity, Spontaneous — —A term formerly employed for the electricity produced by the melting of sulphur.

This term is, of course, not employed at present, since electricity can never, properly speaking, be produced spontaneously.

Electrification, Negative — —The charging of a body with negative electricity. The negative charge.

Electrification, Positive — —The charging of a body with positive electricity. The positive charge.

Electripherous.—A word proposed for anything capable of bearing or transmitting electricity.

This word is unnecessary and its use should not be encouraged.

Electrize, To — —To charge or electrify a body.

The word corresponds to magnetize, to render a body magnetic or endow it with magnetic properties.

The word is sometimes spelled electrise.

Electrizer.—That which electrizes or charges with electricity.

Electro-Biologist.—(See Appendix—*Biologist, Electro.*)

Electro-Bioscopist. — (See Appendix—*Bioscopist, Electro.*)

Electro-Chemical Accumulator. — (See Appendix—*Accumulator, Electro-Chemical.*)

Electro-Chemical Decomposition.—(See Appendix—*Decomposition, Electro-Chemical.*)

Electro-Chemical Filtration.—(See Appendix—*Filtration, Electro-Chemical.*)

Electro-Chronometric Counter. — (See Appendix—*Counter, Electro-Chronometric.*)

Electro-Compound Magnet.—(See Appendix—*Magnet, Electro-Compound.*)

Electro-Culture.—Stimulating the growth of vegetation by means of electricity.

The term is a bad one, since it should equally apply to a similar stimulation of animal growth.

The term electro-culture has been proposed to characterize the electric stimulation of vegetation, which consists essentially in sending an electric current either through the plant whose growth is to be stimulated, or through the earth near the plant.

In an experiment recently tried in France, a kilogramme of potatoes placed in the path of a weak current, under conditions exactly similar to those of an equal weight of potatoes uninfluenced by the electric current, produced 21 kilogrammes of healthy tubers as compared to 12½ kilogrammes of non-electrically stimulated tubers.

These experiments developed the fact that if a quantity of manure be planted near the positive pole of an electric source, the assimilable parts of the manure are transported or carried towards the negative pole.

The phenomena would, therefore, appear to be connected with those of electric osmose or cataphoresis. (See *Osmose, Electric, Cataphoresis.*)

Electrode, Cataphoric — —In electrotherapeutics an electrode impregnated with the medicament it is desired to introduce into the part to be treated by cataphoric medication. (See Appendix—*Medication, Cataphoric.*)

Electro-Deposition.—A term sometimes employed for electric deposition. (See *Metalurgy, Electro.*)

Electro-Dynamic Balance.—(See Appendix—*Balance, Electro-Dynamic.*)

Electro-Dynamic Interrupter.—(See Appendix—*Interrupter, Electro-Dynamic.*)

Electro-Dynamic Rotation.—(See Appendix—*Rotation, Electro-Dynamic.*)

Electro-Dynamic Whirls.—(See Appendix—*Whirls, Electro-Dynamic.*)

Electro-Genesis.—A word proposed for the production of electricity.

Electro-Genic.—Producing electricity.

Electro-Gilding.—(See Appendix—*Gilding, Electro.*)

Electrograph.—A curve produced by a recording electrometer.

Electrography.—A word proposed for that branch of science which treats of electricity.

A word proposed for the copying of fine engraving on copper or steel by means of electro-deposition.

It will be seen that the word electrography has been proposed for two entirely distinct senses. The first use of the word would appear to be entirely unjustifiable.

Electro-Kinetic Energy.—(See Appendix—*Energy, Electro-Kinetic.*)

Electro-Lithotripsy. — (See Appendix—*Lithotripsy, Electro.*)

Electrolization.—The act of being electrolyzed.

The word is sometimes spelled *electrolisation*.

Electrologist.—An electrician.

The use of this word is entirely unnecessary.

Electrolysis, Counter - Electromotive Force of — —The counter-electromotive force produced in a plating bath or a secondary cell by electrolysis.

Electrolyte.—The exciting liquid in a voltaic cell.

A compound liquid which is separable into its constituent ions by the passage of electricity through it.

Electrolytic Accumulator.—(See Appendix—*Accumulator, Electrolytic.*)

Electrolytic Corrosion.—(See Appendix—*Corrosion, Electrolytic.*)

Electrolytic Meter.—(See Appendix—*Meter, Electrolytic.*)

Electro-Magnetic Cut-Out.—(See Appendix—*Cut-Out, Electro-Magnetic.*)

Electro-Magnetic Gyroscope.—(See Appendix—*Gyroscope, Electro-Magnetic.*)

Electro-Magnetic Interference. — (See Appendix—*Interference, Electro-Magnetic.*)

Electro-Magnetic Multiplier.—(See Appendix—*Multiplier, Electro-Magnetic.*)

Electro-Magnetic Separator.—(See Appendix—*Separator, Electro-Magnetic.*)

Electro-Magnetic Sorter.—(See Appendix—*Sorter, Electro-Magnetic.*)

Electro-Magnetic Telegraph.—(See Appendix—*Telegraph, Electro-Magnetic.*)

Electro-Metallurgical Burnt Deposit. —(See Appendix—*Deposit, Electro-Metallurgical Burnt.*)

Electrometer, Heterostatic — —An electrometer in which the electrification to be tested is not the only electrification employed. (See *Heterostatic.*)

Electrometer, Idiostatic — —An electrometer in which the electrification to be tested is the only electrification employed. (See *Idiostatic.*)

Electrometer, Long-Range — —A form of attracted-disc electrometer in which the range of the scale is comparatively long.

Electrometer, Repulsion — —An electrometer in which the differences of potential are measured by means of the repulsion existing between two similarly charged bodies.

Coulomb's torsion balance is an instrument of this class. A gold-leaf electrometer, when arranged so that the amount of deviation can be readily measured, is also a repulsion electrometer.

Electrometer, Symmetrical — —A form of electrometer in which the needle is unaffected when it is placed symmetrically as regards the deflecting segments.

A quadrant electrometer is a form of symmetrical electrometer.

Electrometer, Thermo — —A term sometimes employed for an electric thermometer.

This use of the term probably arose from the fact that such an instrument may be employed to measure roughly the difference of potential between points between which a spark passes.

Electrometer Voltmeter.—(See Appendix—*Voltmeter, Electrometer.*)

Electrometric.—Of or pertaining to an electrometer.

Electromotive Force, Transformation of — —(See Appendix—*Transformation, as of Electromotive Force.*)

Electronome.—A term proposed for a measurer of electricity.

This term is not only unnecessary, but is devoid of any precise meaning and may serve as an

illustration of the thoughtless manner in which electric words are proposed.

Electropath.—One skilled in the art of electro-therapy.

Electropathy.—A word proposed for the treatment of disease by means of electricity.

The word electro-therapy or electro-therapeutics is generally used.

Electro-Percussion Drill.—(See Appendix—*Drill, Electro-Percussion.*)

Electrophone.—A word proposed by Ader for a form of telephone employing carbon contacts.

Electro-Physiologist.—(See Appendix—*Physiologist, Electro.*)

Electro-Potential Energy.—(See Appendix—*Energy, Electro-Potential.*)

Electro-Puncturation.—(See Appendix—*Puncturation, Electro.*)

Electro-Reciprocating Drill.—(See Appendix—*Drill, Electro-Reciprocating.*)

Electroscope, Semaphoric — — A name sometimes given to Henley's quadrant electroscope. (See *Electroscope, Quadrant, Henley's.*)

Electroscopic Gauge.—(See Appendix—*Gauge, Electroscopic.*)

Electrostatic Aurora.—(See Appendix—*Aurora, Electrostatic.*)

Electrostatic Corona.—(See Appendix—*Corona, Electrostatic.*)

Electrostatic Influence.—(See Appendix—*Influence, Electrostatic.*)

Electrostatic Motion.—(See Appendix—*Motion, Electrostatic.*)

Electrostatic Motor.—(See Appendix—*Motor, Electrostatic.*)

Electrostatic Strain.—(See Appendix—*Strain, Electrostatic.*)

Electro-Steeling.—(See Appendix—*Steeling, Electro.*)

Electro-Stereotype.—(See Appendix—*Stereotype, Electro.*)

Electro-Synthesis.—(See Appendix—*Synthesis, Electro.*)

Electro-Thermancy.—(See Appendix—*Thermancy, Electro.*)

Electro-Thermotic.—(See Appendix—*Thermotic, Electro.*)

Electro-Tint.—(See Appendix—*Tint-Electro.*)

Electrotome.—A term formerly applied to an automatic contact breaker which vibrated with sufficient rapidity to produce a musical note. (See *Contact Breaker, Automatic.*)

Electro-Tonicity.—(See Appendix—*Tonicity, Electro.*)

Electro, Turtle-Back — — An electrotype curved so as to be capable of being employed in the cylinder of a rotary newspaper press.

Element of Battery.—A term sometimes applied to a single electric source or a battery of sources.

Element of Voltaic Battery.—A term sometimes applied to a single cell of a voltaic battery.

The term element is properly applied to a single complete voltaic cell only when such a cell forms one of a number of cells so connected in a battery as to form a single electric source.

It would appear that the use of the word element in the case of a single voltaic cell, whether connected with the battery or not, is inadvisable.

Elliptical Rotary Magnetization.—(See Appendix—*Magnetization, Elliptical Rotary.*)

Elongation, Maximum Negative — — The position of a vibrating body when it is at the extremity of its path on the negative side.

Elongation, Maximum Positive — — The position of a vibrating body when it is at the extremity of its path on the positive side.

Emission, Selective — — A selective radiation. (See Appendix—*Radiation, Selective.*)

End-to-End Joint.—(See Appendix—*Joint, End-to-End.*)

Endosmose, Voltaic — —A term sometimes employed in place of electric osmose. (See *Osmose, Electric.*)

Energetics.—That branch of mechanics which treats of the transfer, transformation or modification of energy.

Energy, Cubic — —A term sometimes employed for volumetric energy. (See Appendix—*Energy, Volumetric.*)

Energy, Electro-Kinetic — —Electric energy that is actually engaged in doing work. (See *Energy, Kinetic.*)

Energy, Electro-Potential — —Electric energy possessing the power of, but not actually doing, work. (See *Energy, Potential.*)

Energy, Specific — —Volumetric energy.

Energy, Volumetric — —A term proposed by Hospitalier for a quantity equal to the work divided by the volume.

Energy, Volumetric, C. G. S. Unit of — —An erg per cubic centimetre.

Entering Current of Telegraphic Circuit.—(See Appendix—*Current, Entering, of Telegraphic Circuit.*)

Epoch.—The time reckoned in the case of a vibrating body from the point of reckoning to the point of maximum positive elongation.

Equalizing Wires.—(See Appendix—*Wires, Equalizing.*)

Equatorial Region of Magnet.—(See Appendix—*Region, Equatorial, of Magnet.*)

Ergometer.—A term proposed for an instrument for measuring the amount of work done by a machine.

This would more properly be called an ergometer. The word, however, is seldom used.

Erg : s.—An abbreviation proposed for erg per second, the C. G. S. unit of power.

Error, Heeling, of Mariner's Compass — —The error in deviation of the magnetic needle produced by that portion of the induced and permanent magnetism of the iron in a ship brought into action by the rolling or heeling of the vessel.

Escape.—A term employed in telegraphy for leakage of the current from the line wire or conductor, from the effect of insufficient or faulty insulation, or from contact of the line with wet buildings or other uninsulated bodies.

Escapement, Electric — —An electrically actuated clock escapement.

Evanescence Telegraphic Signal.—(See Appendix—*Signal, Telegraphic, Evanescent.*)

Exciter, Direct Current — —A source of direct current, generally a direct current dynamo, employed for exciting the field magnets of an alternating current dynamo.

Excitation, Electric — —The production of electrification by any means.

Exhausted Plates of Storage Cell.—(See Appendix—*Plates, Exhausted, of Storage Cell.*)

Extension Bell.—(See Appendix—*Bell, Extension.*)

External Magnetic Circuit.—(See Appendix—*Circuit, Magnetic, External.*)

External Magnetic Field.—(See Appendix—*Field, Magnetic, External.*)

F

F.—A symbol proposed for farad, the practical unit of capacity.

F.—A symbol proposed for force.

The defining equation is $F = M \times A$. The same symbol is also proposed for farad.

\mathcal{F} .—A symbol proposed for magnetomotive force.

The defining equation is $\mathcal{F} = 4\pi NI$.

F. M.—A contraction sometimes employed for field magnets.

Fac-Simile Telegraph.—(See Appendix—*Telegraph, Fac-Simile.*)

Factor, Power — —The factor, less than unity, which must be applied to the ap-

parent activity in an alternating current circuit as obtained by the product of the volts and the ampères, in order to obtain the true activity.

With sinusoidal currents and electromotive forces, the power factor is also equal to the cosine of the angle of lag in the current before or behind the pressure.

Fallback Indicator.—(See Appendix—*Indicator, Fallback.*)

Farad, International — —The value of the international farad adopted by the Chicago Congress of 1893 as equal to the capacity of a conductor charged to a potential of one international volt by one international coulomb of electricity.

Faradic Coil.—(See Appendix—*Coil, Faradic.*)

Faradism.—A word sometimes employed for faradization.

Faradization would appear to be the preferable word. (See *Faradization.*)

Fault, Low Test — —A term sometimes applied to a fault in an underground cable when the insulation resistance falls below a certain minimum value, say, for example, 5 megohms per 100 volts per mile.

Fault, Resultant — —The apparent position and magnitude of a fault in a cable due to the resultant of all its leakage upon the electrical measurements made.

Feeder Clamp.—(See Appendix—*Clamp, Feeder.*)

Feeder Clip. — (See Appendix — *Clip, Feeder.*)

Feeder for Trolley Conductor.—A wire or conductor of low resistance, employed for transmitting electric current directly from the power station to the trolley wire, and serving to maintain the potential at the point of junction.

Ferro-Magnetic.—A word sometimes employed in place of paramagnetic.

Ferro-Magnetism.—A word sometimes applied to the magnetism possessed by iron, or, in general, by paramagnetic substances. (See *Paramagnetic.*)

Field Coils of Dynamo.—(See Appendix, *Coils, Field, of Dynamo.*)

Field, Magnetic, Distortion of — —A change in the direction or grouping of lines of magnetic force, in the field of a dynamo-electric machine or electric motor, produced by the reaction of the armature, or the magneto-motive force of the armature current.

This distortion of the field renders it necessary to give a lead to the collecting or distributing brushes. (See *Lead, Angle of. Lead of Brushes of Dynamo-Electric Machine.*)

Field, Magnetic, External — —That portion of a magnetic field which lies outside the magnet or external to it. (See *Field, Magnetic.*)

Field, Magnetic, Internal — —That portion of a magnetic field which lies within the magnet.

Field of Force.—(See Appendix—*Force, Field of.*)

Field Plates.—(See Appendix — *Plates, Field.*)

Field Spools of Dynamo-Electric Machine.—(See Appendix, *Spools, Field, of Dynamo-Electric Machine.*)

Figures, Karsten's — —A name sometimes given to electric breath figures. (See *Figures, Breath.*)

Filament, Coked — —A carbon filament for an incandescent electric lamp that has been subjected to electrical heating in a vacuum, not only until thoroughly freed from its occluded gases, but also until its carbon is changed into a variety of coke.

The coked carbon filament is the invention of Lodyguine. The coking is carried on in a vacuum, the process being continued for about eight seconds after the occluded gases have been driven off.

The carrying off of the occluded gas is effected in the usual manner, and the strength of the current is then increased considerably. Under these circumstances the carbon of the filament becomes changed into a variety of coke.

It is claimed that under the coking process the filament has its permanent or cold resistance greatly decreased until it becomes approximately

of the same value as that of the hot resistance of the filament before it was coked. The process is sometimes carried further than this, depending on the character of the original carbonization.

It is necessary, however, to stop the coking treatment when this point of resistance has been reached, since, if the heating be continued beyond this, the resistance of the filament again rises.

Filament, Coking of — — Subjecting a filament to the coking process. (See *Filament, Coked*.)

Filament, Incandescent — — A filament that is rendered incandescent by the passage of an electric current. (See *Lamp, Incandescent, Electric Filament of*.)

In other words, a filament is incandescent only while it is actually emitting its own light.

Filament, Incandescing — — A filament that can be rendered incandescent by the passage of an electric current. (See *Lamp, Incandescent, Electric Filament of*.)

Filament, Mounting of — — A suitable connection for the filament to the leading-in wires inside the chamber of an incandescent electric lamp.

Filament, Treated Coked — — A carbon filament the core of which has been electrically coked and whose surface is covered with electrically deposited carbon derived from the decomposition of a hydrocarbon gas or vapor.

Filtration, Electro-Chemical — — A term formerly employed in place of electric endosmose. (See *Osmose, Electric. Phenomena, Porret*.)

Finishing Brushes.—(See Appendix—*Brushes, Finishing*.)

Fire Alarm Telegraph.—(See Appendix—*Telegraph, Fire Alarm*.)

Fire Glow.—(See Appendix—*Glow, Fire*.)

Fittings, Combination, for Chandeliers, Brackets, Etc. — — Fittings that provide for the use of both gas and electricity

Five-Wire System.—(See Appendix—*System, Five-Wire*.)

Flash, Multiple Lightning — — Several

lightning flashes that apparently come from the same cloud.

Lodge traces the cause of multiple lightning flashes to the same circumstances that produce in a Leyden jar the tendency of the jar to neutralize its charges by overflowing. (See Appendix—*Jar, Leyden, Overflow of*.)

Flashing.—A process to which carbons are subjected, in order to give them a uniform electrical resistance throughout their entire length. (See *Carbons, Flashing Process for*.)

Flat-Iron, Electric — — An electrically heated flat-iron.

A hollow flat-iron provided with a suitably placed electric heater. (See *Heater, Electric*.)

Floor Contact.—(See Appendix—*Contact, Floor*.)

Fluid, Austral — — A term formerly employed for the magnetic fluid that was supposed to exist around or emanate from the austral pole of a magnet. (See *Pole, Magnetic Austral*.)

Fluid, Boreal — — A term formerly employed for the magnetic fluid that was supposed to exist around or emanate from the boreal pole of a magnet. (See *Pole, Magnetic, Boreal*.)

Fluid, Electric — — An assumed fluid which was formerly believed to be the cause of electric excitement.

A belief in electric fluids no longer exists among intelligent electricians.

Fluid, Magnetic — — A term formerly employed for an assumed fluid which was believed to cause magnetic phenomena.

The belief in magnetic fluids no longer exists.

Fluid, Negative — — A specific fluid which was formerly believed by the advocates of the double-fluid electric hypothesis to be the cause of negative electric excitement. (See Appendix—*Fluid, Positive*.)

A deficit of an assumed single electric fluid. (See *Electricity, Single-Fluid Hypothesis of*.)

Fluid, Positive — — A specific fluid which was formerly believed by the adherents

of the double-fluid electric hypothesis to be the cause of positive electric excitement.

A surplusage of an assumed single electric fluid.

According to the views of the single-fluid electric hypothesis, positive excitement was supposed to be due to the surplusage of an assumed single electric fluid, the negative excitement being assumed to be due to its deficit. (See *Electricity, Single-Fluid Hypothesis of.*)

Flush-Key Switch.—(See Appendix—*Switch, Flush-Key.*)

Force, Electric, Transformation of — —Producing or effecting a change in the value of the electromotive force by means of an induction coil, transformer or condenser, or by electric resonance. (See *Transformer.*)

Force, Electromotive, Alternating — —An electromotive force periodically passing through zero between positive and negative values. (See *Current, Alternating.*)

Force, Electromotive, Conversion of — —A change in the value of the electromotive force produced by means of an induction coil, transformer or condenser, or by electric resonance. (See *Transformer.*)

Force, Electromotive, Impressed, Proposed A. I. E. E. Definition for — —The ratio of the total activity in an electrically conducting circuit to its instantaneous current strength.

Force, Electromotive, Opposing — —A term sometimes employed for counter-electromotive force. (See *Force, Electromotive, Counter.*)

Force, Electromotive, Voltaic — —A term sometimes employed for the electromotive force generated at the electrodes of an electrolytic cell, in contradistinction to the counter-electromotive force produced at such electrodes by their polarization.

Force, Field of — —The space traversed or crossed by the lines of electrostatic or magnetic force.

An electrostatic field. (See *Field, Electrostatic.*)

A magnetic field. (See *Field, Magnetic.*)

Force, Magne-Crystalline — —A name proposed by Faraday for the force assumed as the cause producing the change in the nature of the magnetism of certain crystalline bodies in different directions. (See *Action, Magne-Crystalline.*)

Force, Volta Electromotive — —An electromotive force produced by means of the voltaic cell. (See *Cell, Voltaic.*)

Forces, Electromotive, Complex-Harmonic Alternating — —The electromotive forces producing complex harmonic alternating currents. (See Appendix—*Currents, Complex-Harmonic.*)

Forge, Electric — —A forge so arranged that the metals to be subjected to forging can be electrically heated while in place on the forge.

Formulæ, Blavier's — —The formulæ employed for computing the Blavier test. (See Appendix—*Test, Blavier's.*)

Formulas.—Plural of formula.

Four-Pole Dynamo-Electric Machine.—(See Appendix—*Machine, Dynamo-Electric, Four-Pole.*)

Fourth State or Condition of Matter.—(See Appendix—*Matter, Fourth State or Condition of.*)

Four-Way Switch.—(See Appendix—*Switch, Four-Way.*)

Four-Wire System.—(See Appendix—*System, Four-Wire.*)

Frame, Dynamo or Motor — —A term applied to the iron body of a dynamo or motor, including the pole pieces and standards of the machine, but exclusive of the base plates and bearings. (See *Machine, Dynamo-Electric, Motor, Electric.*)

Frame, Trolley Base — —A frame for receiving the standard which supports the trolley pole.

Franklinism.—A word sometimes employed for franklinization.

Franklinization would appear to be the preferable word. (See *Franklinization.*)

Free or Insulated.—(See Appendix—*Insulated or Free.*)

Frequencies, Harmonic — —Frequencies higher than the fundamental, present in complex-harmonic currents. (See Appendix—*Currents, Complex-Harmonic.*)

Frequencies, Tesla — —A term employed for exceedingly high frequencies.

The frequencies employed by Tesla amounted to many hundreds of thousands per second.

Frequency, Fundamental — —The nominal or lowest frequency of a current which has harmonics.

Frequency, Vibration — —A term expressing the number of vibrations per second.

In the case of a musical note the vibration frequency corresponds to the pitch of the note.

Frog Crossing.—(See Appendix—*Crossing Frog.*)

Frost Alarm.—(See Appendix—*Alarm, Frost.*)

Full Contact.—(See Appendix—*Contact, Full.*)

Full Load.—(See Appendix—*Load, Full.*)

Fundamental Frequency.—(See Appendix—*Frequency, Fundamental.*)

Fuse, Blowing of — —A term sometimes employed for the fusing or volatiliza-

tion of a fuse wire or safety plug. (See *Fuse, Safety.*)

Fuse, Blowing Point of — —The temperature or the current strength at which a fuse blows out or melts.

The exact current strength at which a fuse blows out or melts varies, not only with the temperature of the wire, but also with the position in which the fuse wire is placed in the fuse block, and the nature of the block, its size, whether the current is direct or alternating, etc.

The ratio, which should exist between the carrying capacity of a fuse, and the condition of its ultimate fusing, will of course depend on the character of the circuit the fuse is intended to guard. With small currents, such for example as are employed in electric lighting, a narrow margin may be employed without detriment, but in the case of railway systems, however, a wider range is necessarily given to the blowing point of the fuse, for the amount of current required in such systems, near heavy grades, is so much in comparison to what is ordinarily employed that if too narrow a limit were given to the fusing point considerable annoyance would be experienced from the fuse blowing out too frequently.

Fuse, Safety, Carrying Capacity of — —The current strength a fuse wire or plug can carry without the line it protects becoming dangerously heated.

G

g.—An abbreviation proposed for one gramme, the C. G. S. unit of mass.

g. cm².—An abbreviation proposed for gramme centimetre squared, the C. G. S. unit of moment of inertia.

Galvanic Cell.—(See Appendix—*Cell, Galvanic.*)

Galvanic Chain.—(See Appendix—*Chain, Galvanic.*)

Galvanic Ring.—(See Appendix—*Ring, Galvanic.*)

Galvanist.—One skilled in the “art of galvanism.” (Obsolete.)

The word has no precise meaning, since the word galvanism is employed in two entirely different senses; namely, as current electricity and as a particular method of applying electricity to the curing of diseases.

Galvanoglyphy.—The process of producing an electrotype.

This word, though good etymologically, is unnecessary; moreover, the word electrotype is almost universally employed.

Galvanography.—A term proposed for the copying of fine engravings on copper or steel plates by means of electro-deposition.

Galvano-Magnetic.—A word proposed for electro-magnetic.

The use of this word is unwarranted and should not be encouraged.

Galvanometer, Angle of Maximum Sensitiveness of — — The angle of deflection at which a given small alteration in the strength of the current produces the greatest change in the deflection of the needle.

Galvanometer, Direct Reading — — A galvanometer in which the absolute value of the deflection in current strength is obtained directly without the use of tables or curves.

Galvanometer, Helmholtz — — A double-ring tangent galvanometer, the two ring coils of which are parallel to each other and are placed on opposite sides of the magnetic needle at such positions that their magnetic field at the needle may be as nearly uniform as possible, and much more nearly uniform than a single coil could produce.

Galvanometer, Optical — — A form of galvanometer proposed by Potier based on the magnetic rotary power of liquids. (See *Refraction, Double, Electric.*)

Galvanometer, Pocket — — A galvanometer small enough to be readily carried in the pocket.

Galvanometer Voltmeter.—(See Appendix—*Voltmeter, Galvanometer.*)

Galvanotonus.—A term proposed by Pflüger for the state of tetanus produced in a muscle that has been overstimulated electrically.

Galvanotropism.—Movements produced in living organisms by the passage of electricity through them.

The word galvanotropism has been proposed to describe such phenomena as the movements observed in the roots of plants, when placed between two opposite electrodes. The direction of these movements seems to be such as would place the longer axis of the root in the direction of the plane of the current.

Gap, Air, Shunting — — An air gap in a circuit placed around a galvanometer or other instrument for the purpose of affording protection to the galvanometer or other instrument from the effects of powerful disruptive discharges.

The inductive resistance of the coil to the rapidly varying oscillatory discharges is so great that the discharges take instead a path through an air gap. Since such an air gap thus shunts the discharge from the galvanometer or other coils, it is called a shunting air gap.

Gas Cell.—(See Appendix—*Cell, Gas.*)

Gas Polarization.—(See Appendix—*Polarization, Gas.*)

Gauge, Electric Pocket — — A gauge for an electric battery or other similar source small enough to be readily carried in the pocket.

Gauge, Electroscopic — — A term applied by Gaugain to a form of discharging gold-leaf electroscope. (See *Electroscope, Gold-Leaf.*)

Gauss, Proposed A. I. E. E. Definition for — — A practical unit of magnetic intensity, the value of which is equal to one C. G. S. unit; that is, one C. G. S. line per square centimetre.

This unit is a modification of that proposed by a Sub-Committee of the American Institute of Electrical Engineers on the Provisional Programme for the International Electrical Congress, held in Chicago, 1893, on the occasion of the World's Columbian Exposition.

Generator, Chemical, of Electricity — — A term sometimes employed in place of a voltaic pile or battery.

This use of the term generator is sanctioned by the similar use of the word in other connections. Of course it will be understood that it is difference of potential and not electricity that is generated.

Generator, Diphasé — — A generator which delivers two-phase or diphasé currents.

Generator, High-Voltage Electro-Magnetic — — An electro-magnetic generator arranged so as to give a high electromotive force.

Generator, Polyphase — — A generator which delivers more than single-phase currents.

The term polyphase is frequently employed only in the sense of greater than diphasé.

Generator, Railway — — A dynamo-

electric machine which develops the current employed in systems of electric railways.

Generator, Self-Compounding Polyphase — —A polyphase generator whose field magnets are compound-wound.

Generator, Thermo-Electric — —A term sometimes employed for a thermo-electric pile. (See *Pile, Thermo-Electric.*)

The term is equally applicable to the pyromagnetic generator.

Generator, Three-Phase — —A tri-phase generator. (See Appendix—*Generator, Tri-Phase.*)

The term tri-phase generator would appear to be preferable.

Generator, Tri-Phase — —A generator which delivers three-phase or tri-phase currents.

Generator, Two-Phase — —A di-phase generator. (See Appendix—*Generator, Di-Phase.*)

The term di-phase generator would appear to be preferable.

Gilbert.—A term proposed for the practical unit of magneto-motive force.

A unit of magneto-motive force having the value of the absolute unit or equal to

$$\frac{10}{4\pi} \text{ ampère-turn.}$$

This unit is a modification of that proposed by a Sub-Committee of the American Institute of Electrical Engineers on Provisional Programme for the International Electrical Congress, held in Chicago, in 1893.

Gilding, Electro — — Electric gilding. Electro-plating with gold. (See *Gilding, Electric.*)

Glass Screw Insulator.—(See Appendix—*Insulator, Glass-Screw.*)

Globes, Diffusing, for Electric Lights. — — Globes so constructed as to insure a diffusion of the light.

The diffusion is generally obtained by means of ground glass. In order to avoid the loss of light that attends the use of ground glass, diffusion globes have been made of clear glass furnished with a number of refraction or total internal re-

flecting lenses, in the manner of the well-known Fresnel lens.

Glory, Aurora — —A term proposed by Nordenskjöld for an almost constant crown of light, single, double or multiple, which occupies a nearly fixed position in the heavens.

Nordenskjöld describes the aurora glory as follows:

“Our globe, even during a minimum aurora year, is adorned with an almost constant crown of light, single, double, or multiple, whose inner edge was usually, during the winter of 1878-79, at a height of about 0.03 of the radius of the earth (120 miles) above its surface, whose surface was somewhat under the earth's surface, having its centre a little north of the magnetic pole, and which, with a diameter of about 0.32 radius of the earth (about 1,280 miles), extends in a plane perpendicular to the earth's radius which passes through the centre of this luminous ring.”

Glow, Fire — —A term employed by the ancients for an aurora. (See *Aurora Borealis. Aurora Australis.*)

Glow Illumination.—(See Appendix—*Illumination, Glow.*)

Glow Lamp.—(See Appendix — *Lamp, Glow.*)

Glowing of Electric Conductor.—(See Appendix—*Conductor, Electric, Glowing of.*)

Glue-Pot, Electric — —An electrically heated glue-pot.

An electric heater is applied to a glue-pot of ordinary construction. (See *Heater, Electric.*)

Gnomon, Electric — —A term formerly applied to a variety of pith ball electrometer.

Good Earth.—(See Appendix — *Earth, Good.*)

Ground Coil.—(See Appendix — *Coil, Ground.*)

Ground, Dead — —A term sometimes applied to a fault or interruption in a telegraphic line in which the escape to earth or ground is so great that it is impossible to operate the line.

Dead earth. (See *Earth, Dead or Total.*)

Grounding.—A word sometimes employed

n electro-metallurgy for a preparatory process in burnishing. (See Appendix—*Burnishing*.)

Grouping System for Electric Light Leads.—(See Appendix—*Leads, Grouping System for Electric Light*.)

Guard, Automatic, for Series-Connected Incandescent Lamps — —A device placed on each series-connected incandescent electric lamp for the purpose of short circuiting

the holder should the lamp filament break.

A film cut-out. (See *Cut-Out, Film*.)

An automatic guard may consist of a sheet of paraffine paper placed between two metallic knobs.

Gyroscope, Electro-Magnetic — —A gyroscope driven by an electro-magnet.

Gyrostatic Action of Dynamos on Shipboard.—(See Appendix—*Action, Gyrostatic, of Dynamos on Shipboard*.)

H

H.—A symbol used for field intensity.

The defining equation is $H = \frac{F}{m}$.

Here F = the force and m the strength of the pole.

H.—An abbreviation proposed for henry, the practical unit of mutual induction, self-induction, or inductance.

This abbreviation is seldom used.

h.—An abbreviation for hour, one of the practical units of time.

ℋ.—A symbol proposed for magnetizing force.

The defining equation is $\mathcal{H} = \frac{4\pi NI}{L}$.

Where N, is the number of windings, and L, the length of the solenoid generating the magnetizing force.

HP or H.P.—A contraction for horse-power.

This contraction is universally employed in all English-speaking countries.

Harmonic Frequencies.—(See Appendix—*Frequencies, Harmonic*.)

Harmonic Motion.—(See Appendix—*Motion, Harmonic*.)

Harmonic Telegraph.—(See Appendix—*Telegraph, Harmonic*.)

Harmonics, Electrical — —A term sometimes employed in place of the upper harmonic currents generally. (See Appendix—*Currents, Complex-Harmonic*.)

Harmonics of Current.—(See Appendix—*Current, Harmonics of*.)

Harmonics, Weeding-Out of — —Getting rid of, or removing some or all of the upper harmonic currents from a fundamental harmonic current.

The weeding-out process is generally effected by means of electric resonance. The presence of self-induction or capacity in the circuit has the same effect. It is partly on this account that we cannot yet speak across the Atlantic cable, the upper harmonics of the voice being weeded out more than the lower and made to lag more. (See Appendix—*Harmonics, Weeding-Out of, by Electrical Resonance*.)

Harmonics, Weeding-Out of, by Electrical Resonance — —The weeding-out of the upper harmonics of a complex-harmonic current by altering the natural period of the system until it is in unison or in resonance with the fundamental harmonic.

“A resonant circuit,” says Pupin, “behaves towards a complex-harmonic electromotive force just the same as an acoustic resonator toward a source of complex sound. It brings out prominently that harmonic with which it is in resonance. To express this numerically, say that the ratio of the amplitude of the fundamental harmonic electromotive force to that of the next higher harmonic (supposing it to be even no higher than an octave) is 2 to 1. Then the circuit can be easily brought into resonance with the fundamental harmonic in such a way as to increase the ratio of the amplitudes of the corresponding simple harmonic currents 60 : 1. Theoretically (and to a great extent practically also) that ratio can be made anything we please by increasing continually the coefficient of self-induc-

tion and diminishing the capacity without destroying the resonance. In other words, we can, by the proper single tuning, weed out the upper harmonics as much as we please. But, as will be indicated later on, it is not always advisable to avail ourselves too much of a means of weeding out the upper harmonics by using very large self-induction. The best method of tuning depends on the nature of the problem before us."

Harpoon, Electric — —A harpoon containing a bomb, that is electrically fired or exploded by the harpooner after imbedding the harpoon.

Heat, Electrical Equivalent of — —A quantity representing the electrical energy produced by the action of a given amount or quantity of heat energy.

Heater, Coil, Electric — —An electric heater in which the heat is produced by the passage of an electric current through a coiled metallic ribbon.

A form of coil heater is shown in Fig. 573.

Heater, Primary Electric — —A term proposed for the main electric heater in a building. (See *Heater, Electric*.)

Healing Error of Mariner's Compass.—(See Appendix—*Error, Healing, of Mariner's Compass*.)

Helix.—A word sometimes used in electricity and magnetism in place of coil or solenoid. (See *Coil, Electric*.)

Helix, Anomalous — —A helix so wound as to produce an anomalous magnet. (See *Magnet, Anomalous*.)

Helix, Left-Handed — —A term sometimes employed in place of a left-handed

solenoid. (See *Solenoid, Left-Handed, Solenoid, Practical*.)

Helix, Magnetic — —A coil that is rendered magnetic by the passage through it of an electric current. (See *Coil, Electric*.)

Helix, Magnetizing — —A magnetizing coil. (See *Coil, Electric*.)

Helix, Right-Handed — —A term sometimes employed in place of right-handed solenoid. (See *Solenoid, Right-Handed, Solenoid, Practical*.)

Helmholtz Galvanometer.—(See Appendix—*Galvanometer, Helmholtz*.)

Henry, International — —The value of the international henry adopted by the Chicago Congress of 1893, as equal to the induction in a circuit when the electromotive force induced in this circuit is one international volt, while the inducing current varies at the rate of one ampère per second.

Henry, Proposed A. I. E. E. Definition for — —The name adopted by the Electrical Congress of 1893 for the practical unit of inductance.

A unit of inductance having the value of 10^9 absolute units, or nearly the length of an earth's quadrant.

This name was proposed by a Sub-Committee of the American Institute of Electrical Engineers on Provisional Programme of the International Electrical Congress, in Chicago, 1893, on the occasion of the World's Columbian Exposition.

This name was adopted by the said International Electrical Congress in August, 1893, with the following definition:

A henry is the induction in a circuit when the electromotive force induced in this circuit is one international volt, while the inducing current varies at the rate of one international ampère per second.

Heptad Atom.—(See Appendix—*Atom, Heptad*.)

Hertz's Axial Oscillator.—(See Appendix—*Oscillator, Hertz's Axial*.)

Hertz's Linear Oscillator.—(See Appendix—*Oscillator, Hertz's Linear*.)

Hertz's Oscillator.—(See Appendix—*Oscillator, Hertz's*.)

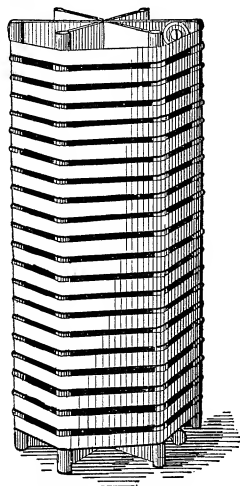

Fig. 573. Coil Heater.

Hertzian Waves.—(See Appendix—*Waves, Hertzian.*)

Heterostatic Electrometer.—(See Appendix—*Electrometer, Heterostatic.*)

Hexad Atom.—(See Appendix—*Atom, Hexad.*)

High-Frequency Transformer.—(See Appendix—*Transformer, High-Frequency.*)

High-Voltage Electro-Magnetic Generator.—(See Appendix—*Generator, High-Voltage Electro-Magnetic.*)

Home Battery.—(See Appendix—*Battery, Home.*)

Hook, Dipping — —A metallic hook provided for holding articles that are to be cleansed, in order to prepare them for electroplating by subjecting them to the dipping process. (See *Dipping.*)

The dipping hook should be made of metal as nearly resembling the article to be plated as possible, so as thereby to prevent voltaic action taking place between the two metals with a consequent marking at the points of contact.

Horizontal Intensity of Earth's Magnetism.—(See Appendix—*Magnetism, Horizontal Intensity of Earth's.*)

Horology, Electric — —That branch of electric science which treats of the applications of electricity to the regulation or operation of clocks. (See *Clock, Electric.*)

Hummer.—A word sometimes employed in place of buzzer. (See *Buzzer, Electric.*)

Hummer, Electric — —A term sometimes used for electric buzzer.

Hunting of Parallel Alternators.—(See Appendix—*Alternators, Parallel, Hunting of.*)

Hysteresis, Dielectric — —A term proposed by Steinmetz for a variety of molecular friction, analogous to magnetic hysteresis, produced in a dielectric under changes of electrostatic stress.

The losses caused by dielectric hysteresis are probably proportional to the frequency and to the square of the E. M. F., *i. e.*, to the electrostatic field intensity.

Losses ascribed to defective insulation are often, in the opinion of Steinmetz, caused, at least in part, by dielectric hysteresis.

Hysteresis, Magnetic — —A variety of molecular friction produced in the molecules of a magnetizable substance during changes of magnetic stress.

According to Steinmetz, the loss occasioned by magnetic hysteresis is proportional to the frequency and to the 1.6th power of the magnetic variation.

According to Steinmetz, for a magnetic cycle performed between the limits of magnetic induction B_1 and B_2 , the loss in ergs per cubic cm. is

$$L = n \left(\frac{B_1 - B_2}{2} \right)^{1.6}$$

where n , the coefficient of hysteresis, averages .0033 in average good sheet iron, .013 in cast iron, .003 to .03 in cast steel, and reaches as high as .08 in hardened steel.

With alternating magnetism the formula can be written

$$L = n B^{1.6}$$

The actual existence of magnetic hysteresis is denied by some able electricians.

I

I.—A symbol proposed for intensity of current.

The defining equation is $I = \frac{E}{R}$

∫ — —A symbol used in France and Germany for intensity of magnetization.

The defining equation is $\int = \frac{\mathfrak{M}}{V}$

Idiostatic Electrometer.—(See Appendix—*Electrometer, Idiostatic.*)

Idle Wire of Armature.—(See Appendix—*Wire, Idle, of Armature.*)

Idle Wire of Armature of Motor.—(See *Wire, Idle, of Armature of Motor.*)

Idle Wire of Dynamo.—(See Appendix—*Wire, Idle, of Armature of Dynamo.*)

Idle Wire of Motor.—(See Appendix—*Wire, Idle, of Armature of Motor.*)

Illumination, Cosine Law of — —The intensity of the illumination emitted from or received by any element of surface is proportional to the cosine of the angle between its normal, and the direction of the radiation.

Illumination, Glow — —A term proposed for an illumination similar to that of the glow-worm; that is, illumination without sensible heat.

All artificial sources of light, such, for example, as a coal-oil lamp, a gas jet, an incandescent electric lamp, or an arc lamp, contain a much greater percentage of non-luminous than of luminous radiation, that is, of heat than light, being at the most a few per cent. of light, and considerably over 95 per cent. of heat.

The most economical artificial lighting is, of course, impossible under these circumstances.

In the light emitted by a firefly or a glow worm, practically all the radiation consists of light or radiation within the limits of visibility.

The term glow illumination has been proposed for illumination by light such as is furnished by a firefly or glow-worm; viz., for the light emitted by any source which is capable of producing luminous radiation only. In some forms of Tesla lamps the illumination closely approaches glow illumination.

Immediate False Zero.—(See Appendix—*Zero, Immediate False.*)

Incandescent Bombardment Lamp.—(See Appendix—*Lamp, Incandescent Bombardment.*)

Incandescent Filament.—(See Appendix—*Filament, Incandescent.*)

Incandescent Lamp Cord.—(See Appendix—*Cord, Incandescent Lamp.*)

Incandescent Lighting Dynamo-Electric Machine.—(See Appendix—*Machine, Dynamo-Electric, Incandescent Lighting.*)

Incandescing Filament.—(See Appendix—*Filament, Incandescing.*)

Inclination Magnetometer.—(See Appendix—*Magnetometer, Inclination.*)

Indicator, Disc, Mechanical Replacement of — —Such a replacement or resetting of

a disc, arm, shutter or semaphore of an indicator as must be done by hand.

A non-automatic replacement of an indicator disc.

Indicator, Fall-Back — —A term sometimes employed in place of drop indicator.

Indicator, Light, of Railroad Signal — —A device by means of which an indication is given as to whether a signal lamp is lighted or not.

The light indicator is operated by means of a metallic bar, which increases in length by means of the heat of the lamp when lighted.

Indicator, Polarized — —A term sometimes employed for an indicator provided with a polarized armature.

Indicator, Pole — —An apparatus employed for readily determining whether the poles of a dynamo battery or other source are positive or negative.

A convenient form of pole indicator consists of a small electrolytic cell filled with a solution of a metallic salt. On the passage of the current through the electrolyte the character of the poles is readily determined by the change in color of the liquid adjacent to one pole of the indicator.

There are other well-known forms of pole indicators.

Indicator, Tele — —A term sometimes employed in place of telemeter. (See *Telemeter.*)

Indicator, Telephone — —An indicator employed on a telephone circuit to indicate the number of the correspondent calling. (See *Indicator, Electric.*)

A telephone indicator, as generally constructed, consists of some form of mechanical drop operated by the attraction of the armature of an electro-magnet which, permitting the fall of a drop or shutter, exposes the particular number of the correspondent calling.

Indicator, Tri-Polar — —An electromagnetic indicator, with three poles.

A straight bar magnet is employed, one end of which forms one pole and the other end is connected with a U-shaped piece of soft iron, so as to bring the two free ends of the latter up to the

line on the other pole. There are thus produced three poles; hence, the name, tri-polar.

Indifferent Point.—(See Appendix—*Point, Indifferent.*)

Individual Signal.—(See Appendix—*Signal, Individual.*)

Individual Signaling Apparatus.—(See Appendix—*Apparatus, Individual Signaling.*)

Induced Electric Surgings.—(See Appendix—*Surgings, Induced Electric.*)

Induced Single-Needle Dial.—(See Appendix—*Dial, Induced Single-Needle.*)

Inductance, Mutual, Proposed A. I. E. E. Definition for — —The mutual inductance of one electric circuit upon another is the ratio of the total magnetic induction linked with the second, due to a uniform current in the first, to the strength of that current.

The mutual inductance between two electric circuits is reciprocally equal when the environing medium has constant inductivity.

The C. G. S. unit of mutual inductance is one centimetre; the practical unit of self-inductance is one henry.

The following modification of the definition would appear to be preferable, viz. : the mutual inductance of one circuit on another is the ratio of the sum of the linkages of lines of magnetic induction with the second, due to a uniform current in the first, to the strength of that current.

Inductance, Non-Ferrie — — A term proposed to distinguish an inductance in which no iron or magnetic metal enters.

A coil of copper forms a non-ferric inductance; the insertion of an iron core into the coil makes it become a ferric inductance.

Inductance, Self, Proposed A. I. E. E. Definition for — —The ratio of the total magnetic induction, linked with and established by an electric current, to the uniform strength of the same.

The inductance of a conducting circuit is constant when its environing medium has constant inductivity. A modification has been proposed for this definition similar to that proposed for mutual inductance.

Inductance, Specific — —A term proposed for the comparative value of inductance. (See *Inductance.*)

Inductance Speed.—(See Appendix—*Speed, Inductance.*)

Inducteous Body.—(See Appendix—*Body, Inducteous.*)

Induction, Auto — —A term sometimes employed instead of self-induction. (See *Induction, Self.*)

Induction, Backward, of Dynamo Armature — — The component of the armature magnetization opposing the magnetization of the field magnets. (See Appendix—*Induction, Cross, of Dynamo Armature.*)

Were there no forward lead given to the brushes, there would be no back induction; there would, however, be cross induction.

Induction, Cross, of Dynamo Armature — —A term sometimes employed in place of the induction produced in the armature of a dynamo-electric machine from the ampère turns acting across the main magnetic circuit, *i. e.*, those due to the current in the armature, and is the lead of the brushes tending to produce magnetic poles crosswise to the regular poles of the machine.

Induction, Magne-Electric — —A term formerly employed for magneto-electric induction. (See *Induction, Magneto-Electric.*)

Induction, Magnetic, Terrestrial — — The production of magnetism by the action of the earth's magnetic field.

Induction Motor.—(See Appendix—*Motor, Induction.*)

Induction Telegraph.—(See Appendix—*Telegraph, Induction.*)

Inductivity.—A word proposed for specific inductance. (See Appendix—*Inductance, Specific.*)

Inductivity, Proposed A. I. E. E. for — —The inductivity at any point in an isotropic medium is the ratio added to unity of 4π times the intensity of the magnetization there existing to the magnetizing flux density.

The ratio of the flux density to the magnetizing force.

The conventional symbol is μ and it is synonymous with permeability.

Inductric Body.—(See Appendix—*Body, Inductric.*)

Influence, Electrostatic — —A word sometimes employed in place of electrostatic induction. (See *Induction, Electrostatic.*)

There would appear to be no real necessity for the abandonment of the term induction for the effects produced by an electrostatic field. The general similarity of the phenomena would, indeed, appear to render it advisable to retain the word electrostatic induction, to show its close relation to electro-magnetic induction.

In-Put.—The energy absorbed by a machine in driving it or causing it to perform a certain amount of work.

This word is used in contradistinction to output.

Inside Box Brush.—(See Appendix—*Brush, Inside Box.*)

Instrument, S. N., Telegraphic — —A contraction employed for single-needle telegraphic instrument.

Insulated or Free — —A term employed in telegraphy.

A wire is said to be free insulated when it is disconnected from its apparatus and left insulated.

Insulation, Kilometric, of Cable — —The insulation of a cable measured in kilometre-megohms or the average insulation of one kilometre in megohms.

Insulation Lightning Protection.—(See Appendix—*Protection, Insulation Lightning.*)

Insulation Lightning Protector.—(See Appendix—*Protector, Insulation Lightning.*)

Insulator, Glass-Screw — —A glass insulator provided with a screw thread inside the glass for the purpose of ready attachment to the insulator pin.

Insulator, Shackle — —A term sometimes employed for any form of shackle in-

ulator. (See *Insulator, Single-Shackle, Insulator, Double-Shackle.*)

Insulator, Tree — —A variety of insulator suitable for attachment to trees, and designed so as to keep the conductor from being brought into contact with the branches.

The insulator proper is mounted on a shaft which plays in a ball and socket joint, the cup of which is fastened to the tree; the line is therefore kept in its normal position despite the movements of the tree.

In-Take.—A word sometimes used in place of In-Put.

Intensity of Radiation.—(See Appendix—*Radiation, Intensity of.*)

Interference, Acoustic — —Interference of sound waves.

The term acoustic interference is employed in contradistinction to luminous interference.

Interference, Electro-Magnetic — —A term sometimes employed for the interference of electro-magnetic waves.

The term electro-magnetic interference is employed in contradistinction to acoustic or luminous interference, even though it be granted that luminous waves are electro-magnetic waves.

Interference, Luminous — —A term sometimes employed for the interference of light waves.

The term luminous interference is used in contradistinction to acoustic or electric interference.

Internal Magnetic Circuit.—(See Appendix—*Circuit, Magnetic, Internal.*)

Internal Magnetic Field.—(See Appendix—*Field, Magnetic, Internal.*)

International Ampère.—(See Appendix—*Ampère, International.*)

International Coulomb.—(See Appendix—*Coulomb, International.*)

International Farad.—(See Appendix—*Farad, International.*)

International Henry.—(See Appendix—*Henry, International.*)

International Joule.—(See Appendix—*Joule, International.*)

International Morse Code.—(See Appendix—*Code, International Morse.*)

International Ohm.—(See Appendix—*Ohm, International.*)

International Volt.—(See Appendix—*Volt, International.*)

International Watt.—(See Appendix—*Watt, International.*)

Interrupter, Electro-Dynamic — — A name proposed by Pupin for an interrupter for the primary circuit of an induction coil consisting of an elastic wire stretched like the wire of a sonometer or monochord between the poles of a permanent horseshoe magnet.

The term sonometer interrupter might, perhaps, be more descriptive of the apparatus employed.

The circuit connections are such that when the wire is set into vibration these vibrations are continued under the action of the field produced by the magnet. The construction and operation of an electro-dynamic interrupter are given by its inventor, Pupin, as follows:

“In the meantime experience suggested the form given in Fig. 574 as best suited to the purpose for which the interrupter was first designed. The diagram of Fig. 575 explains the

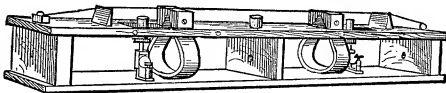

Fig. 574.

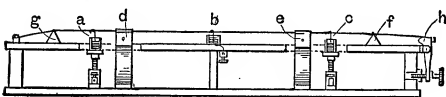

Fig. 575.

construction of the apparatus more clearly. A stout aluminium, or phosphor-bronze wire, *the vibrator*, is stretched between the pole pieces d and e, of two permanent Weston magnets, such as this distinguished electrician uses in his voltmeters.

“Fig. 576 gives the front view of one of the magnets. The cross-section of the vibrator is seen there between the pole pieces N, S, as a black dot. The short line a b extending from the vibrator to the mercury cup below is the dipper, a short, thin, amalgamated copper wire, which is soldered to the vibrator. The vibrator rests on

two hard rubber bridges f g. One of its ends is rigidly attached to the wooden frame of the apparatus, the other end is attached to a lever h, which, worked by a micrometer screw, varies the tension of the vibrator.

There are three mercury cups, a, b, c, and three dippers (which unfortunately do not appear in Fig. 574). The middle cup b, is fixed in position, and the middle dipper, being at the nodal point of the vibrator, makes a permanent contact there.

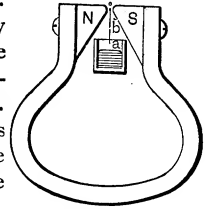

Fig. 576.

The other two dippers make contact with mercury cups which can be raised or lowered by means of a nut and screw as represented in Fig. 574, and indicated in diagram 575. The construction of the adjustable mercury cups and the stretching lever were copied from Dr. Max Wien's magnetic interrupter (*Wiedem. Ann.* 1891 and 1892). The middle cup (see Fig. 577) is connected to one pole, F, of the gravity or storage cell, the other two cups are connected one to one end and the other to the other end of the primary of the

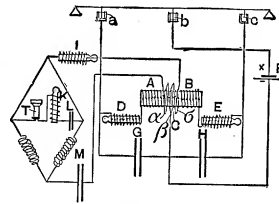

Fig. 577.

small coil A B. From the middle point, C, of the primary a wire leads to the other pole of the cell. Auxiliary small coils, E and D, and condensers, H and G, are inserted in the circuits as indicated. Their functions will be explained further below.

“The vibrator vibrates with a node at the middle dipper as soon as the tension has reached a certain, by no means high, limit. A permanent contact is therefore maintained at this point, and the contact is made at one of the cups just at about the same moment as it is broken at the other cup. Leaving the condensers out of consideration for the present, it is evident that this form of the current make-and-break produces the same effect upon the iron core of the coil as an alternating current would. The advantage of this needs no comment; but although the iron core consists of the finest iron wire that can be obtained in the market, yet it must be remem-

bered that the vibrator is expected to work sometimes at the rate of 512, or more, complete periods per second. Another immediate advantage which this interrupter offers is a considerable diminution of sparking. The addition of condensers, besides performing other functions which will be discussed presently, reduces the break sparks almost to invisibility, even when currents as large as half of an ampère are used. Each half of the primary coil consists of 532 turns of No. 22 silk-covered wire wound over an iron core of 30 centimetres in length, 4 square centimetres in cross-section, and consisting of very fine, soft iron wire."

Interrupter, Sonometer — — A term sometimes employed in place of electrodynamic interrupter. (See Appendix—*Interrupter, Electro-Dynamic.*)

Interrupter, Telegraphic — — A device for making and breaking a circuit at a definite rate.

A telegraphic key or other analogous device.

Interrupter, Telegraphic, Mechanical — — A form of mechanical telegraphic sounder for learners in which no battery is required.

A mechanical telegraphic interrupter is provided with a full-size key with a full set of adjustments. In fact, it resembles an ordinary key, except in that it requires no battery to operate it. It differs, therefore, from the snapper sounder, which is not intended to resemble a sounder, but merely to give the sounds of the Morse characters with the simplest mechanism.

Interruption, Telegraphic — — A term sometimes employed in telegraphy for faults in general.

According to Pope, telegraphic faults or interruptions arise from the following causes, viz.:

- (1.) Disconnections or breaks.
- (2.) Partial disconnections or resistance.
- (3.) Escapes.
- (4.) Crosses.

Ions, Migration of — — A term employed to express the movement of the ions in an electrolyte during electrolysis.

The hypothesis of Gröthuss attempts to explain the fact that in electrolysis the anions and kathions do not appear in any part of the electrolyte ex-

cept at the electrodes, no ions apparently being set free in the liquid. (See *Hypothesis, Gröthuss'.*)

When copper electrodes are employed in the electrolysis of a solution of copper sulphate, the solution becomes from two to three times weaker at the kathode than at the other electrode. Hittorf explains this fact on the assumption that during the migration the SO₄ radical moves through the liquid more rapidly than the Cu radical.

Gröthuss' hypothesis has been objected to because it requires a finite force to bring about the decomposition of the electrolyte, and the experiments of Helmholtz prove that the interior of an electrolyte is unable to withstand the slightest electrostatic stress. Clausius has modified Gröthuss' hypothesis so as to bring it more into accord with the kinetic theory of matter. He believes that some of the moving molecules of the electrolyte are broken up into their constituent ions as a result of occasional molecular impact, and that it is these separated ions only that appear at the electrodes. Arrhenius asserts that during electrolysis the greater part of the molecules of the electrolyte are thus dissociated. The velocity of the dissociated ions is assumed to be proportioned to the potential gradient in the electrolyte. According to this theory a continuous movement of positively charged ions occurs towards the negative electrode or kathode and of negatively charged ions towards the positive electrode or anode.

Iron, Building — — A heated iron tool, by means of which the mould impressed by the printed page, it is desired to electrotype, is built up preparatory to being placed in the electroplating bath.

A building iron consists essentially of a suitably shaped iron tool which is employed while hot in connection with strips of wax for bringing up or raising the blank spaces in a mould between the pages and paragraphs.

Iron-Loss in Transformer.—(See Appendix—*Transformer, Iron-Loss in.*)

Isonisation.—A term proposed for a decrease in the strength with which the separate atoms or radicals are held together in the molecules of an electrolyte.

A term proposed for that modified dissociation of a molecule which consists in a

weakening of the force which holds the ions of the molecules together in an electrolyte.

The term isonisation does not, as might be supposed, refer to the complete separation of an electrolyte into its ions by electrolysis, but to a preparatory weakening of the bonds which hold the ions together in a solution in which electrolysis is about to occur.

This term was proposed by Fitzgerald for the purpose of covering the peculiar action of electrolysis so far as its behavior to aqueous solutions of metallic salts is concerned.

Isotropic.—Homogeneous with respect to direction.

Employed in reference to the properties of a medium.

J

Jack Switch.—(See Appendix—*Switch, Jack.*)

Jar, Leyden, Overflow of — —A term sometimes employed for the discharge of a Leyden jar by a disruptive discharge around its edge.

Joint, End-to-End — —A term frequently employed in place of butt joint. (See *Joint, Butt.*)

Joint, Sliding — —An expansion joint. (See *Joint, Expansion.*)

Joule, International — —The value of the international joule adopted by the Chicago Congress of 1893, as equal to 10^7 units of work in the C. G. S. system, and which is

represented sufficiently well for practical use by the energy expended in one second by one international ampère in an international ohm.

Joule-Meter.—Any apparatus capable of measuring energy in joules.

An energy meter as distinguished from a watt-meter.

Jumper.—A temporary shunt or circuit put around a lamp or loop on a series circuit, to enable it to be readily removed or repaired.

A jumper usually consists of a piece of wire of sufficient size to carry the current past the faulty lamp or other device which it is desired to temporarily remove or repair.

K

K.—A symbol for moment of inertia.

The defining equation is $M \times L^2$.

K (Kappa).—A symbol proposed for magnetic susceptibility.

The defining equation is $K = \frac{J}{\mathcal{H}}$ i. e. $\frac{I}{H}$

kg.—An abbreviation for kilogramme, the practical unit of mass.

kg: cm².—An abbreviation proposed for kilogramme per square centimetre, the practical unit of pressure.

kgm.—An abbreviation for kilogramme, the practical unit of moment of a couple or of work.

kgm: s.—An abbreviation proposed for kilogramme per second, the practical unit of power.

KR.—A contraction for the total capacity of a telephone wire or conductor multiplied by its total resistance.

KR Law.—(See Appendix—*Law, The KR.*)

Kapp Line. — (See Appendix — *Line, Kapp.*)

Karsten's Figures.—(See Appendix — *Figures, Karsten's.*)

Kathodic Rays of Vacuum Tube.—(See Appendix—*Rays, Kathodic, of Vacuum Tube.*)

Kerite Tape. — (See Appendix — *Tape, Kerite.*)

Key, Break — —A key which breaks or opens the circuit when depressed.

Key, Strap — — A telegraphic key formed of a single plate of elastic material.

The elastic strip of conducting material is fixed at one end. Its motion in one direction is effected by the hand of the operator, and its return in the opposite direction by the elasticity of the material.

Key, Successive Contact — — A key so arranged as to make or break one contact after another.

A successive contact key is frequently used in connection with a Wheatstone bridge; where it is desirable to make or close the battery circuit before making or closing the galvanometer circuit, or to break the battery circuit after breaking or opening the galvanometer circuit. This is done by means of a successive contact key. A successive contact key is also sometimes called a double contact key. (See *Key, Double-Contact Form of Bridge, Sprague's. Key, Double-Contact, Lambert's.*)

Key, Tapper — — A term sometimes employed in place of Morse tapper. (See Appendix—*Tapper, Morse.*)

Kick of Relay.—A momentary effect, more powerful than usual, produced on the armature of a relay by the current of charge on the closing of the circuit.

The kick varies in its amount or intensity not only with the electrostatic capacity of the line, but also with its length and with the perfection of its insulation.

Kilerg.—A kilo-erg.

Kilo-Erg.—One thousand ergs.

Kilo-Volt.—One thousand volts.

Kilometric Capacity of Cable.—(See Appendix—*Capacity, Kilometric, of Cable.*)

Kilometric Insulation of Cable.—(See Appendix—*Insulation, Kilometric, of Cable.*)

Kinematics.—That branch of mechanics which treats of motions, irrespective of the mass moved or the forces which produce or oppose its motion.

Kinetics.—That branch of dynamics which treats of the action of forces in producing or modifying motion.

Krizik's Cores.—(See Appendix—*Cores, Krizik's.*)

L

L_m .—A symbol proposed for co-efficient of mutual induction.

L_s .—A symbol proposed for co-efficient of self-induction or inductance.

The defining equation is $L_s = \frac{\Phi}{I}$

Lag, Translation — — A term proposed by Elihu Thomson, who defines it as follows: "Lag due to the traverse of a conductor conveying current past a magnet pole, whereby the action of the current in that conductor becomes displaced in the direction of the motion and produces a moving field, the iron mass or body tending to accommodate itself to the direction of the lines of force in the moving field."

The phenomena of a shifting field are observed when a coil with an iron wire core is energized by an alternating current so as to produce an

alternating field, and a wheel made up of iron discs around which is a rim or band of copper overhanging the edges of the disc is placed in such field. On the energizing of the coil, the wheel, which is mounted on pivots, when mechanically started in rotation in either direction, will increase both in speed and torque to a degree depending on the frequency of the current, the friction to be overcome on the alternating field and on the iron and copper of the wheel. (See *Field, Magnetic, Shifting.*)

Lamp, Arc, Striking Mechanism of — — The mechanism in an arc lamp by means of which the carbons are separated to the distance at which it is desired the arc shall be maintained between them.

Lamp, Bombardment, Electrical — — A lamp in which the light is produced in a vacuous space by means of the bombard-

ment of the molecules of the residual gas by the passage of electrical discharges.

The molecules in their rapid to-and-fro motions are caused to strike against, and thus raise to incandescence, strips or bars of refractory material, such as carbon, etc.

Tesla's straight-filament incandescent electric lamp is a form of electric bombardment lamp. (See *Lamp, Incandescent, Straight-Filament.*)

Lamp, Burned-Out Incandescent — —

A term sometimes employed for an electric incandescent lamp which is no longer able to furnish efficient electric light.

An incandescent electric lamp is, strictly speaking, to be regarded as burned out when it no longer furnishes a suitable light, and this, whether the filament or chamber has been actually destroyed or not.

Lamp, Electric, Efficiency of — —

Strictly, the ratio of the luminous energy emitted by the lamp, to the energy absorbed by the lamp.

The term efficiency of a lamp is less accurately used to signify its relative watts per candle power. The Edison lamps are of high efficiency if 3.1 watts per c. p., and of low efficiency if greater.

Lamp, Electric Stopper — — A term now generally employed for an incandescent electric lamp in which the chamber is stopped, not as formerly by the fusion of the glass, but by the action of a glass stopper hermetically sealed by the use of suitable cement.

Fig. 578 shows a lamp of this type.

Lamp, Glow — — A lamp

the light of which is produced by glow illumination. (See Appendix—*Illumination, Glow.*)

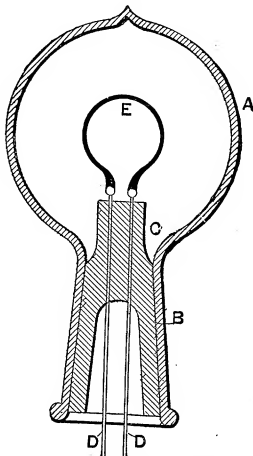

Fig. 578. Electric Stopper Lamp.

The term glow lamp is already generally employed in England and Germany for the ordinary incandescent electric lamp. It would appear that the term incandescent lamp generally employed in America is preferable. The term glow-lamp should be limited, as above, to a lamp producing an approximately cold light; namely, a lamp operating by glow illumination.

Lamp, Incandescent Bombardment — —

—An electric lamp in which a refractory material is rendered incandescent by the molecular bombardment produced by the passage of an electric discharge through a rarefied space.

Most of Tesla's lamps are of the bombardment type and are of a great variety of forms, but in all of them refractory substances like carbon are rendered incandescent by the passage of very rapidly alternating currents through rarefied gases. (See *Lamp, Electric, Incandescent Ball, Lamp, Incandescent, Straight Filament.*)

Lamp, Incandescent Electric, Ageing of

— — A term sometimes employed for a gradual decrease in the economical light emitted by an incandescent electric lamp attending its continued use.

Lamp, Phosphorescent — — A lamp whose light is obtained by means of the phosphorescent effects attending the discharges of electricity through a rarefied space.

In phosphorescent lamps the phosphorescent effects are produced by causing the molecules of the residual gas to strike against some readily phosphorescent material. Such lamps are sometimes called bombardment lamps. But the term bombardment lamp is [perhaps more properly restricted to cases where molecular bombardment raises a substance of high refractory power, such as carbon, to incandescence; while the term phosphorescent lamps is limited to cases where the material so raised to luminescence is a phosphorescent material. (See *Bombardment, Molecular.*)

Law, The KR. — — A generalization claimed by some as a law, but denied by most, which assigns a limit to the distance through which intelligible telephonic communication can be carried on to cases where the product of K, the capacity of the tele-

phone circuit, multiplied by R, its resistance, does not exceed a certain value.

Preece originally fixed the limits of intelligible communication of speech by means of a telephone to cases where the product of K and R did not exceed 15,000. Preece's figures do not agree with the results of practical telephone work in the United States; such, for example, as in the case of the line now in actual operation between Boston and Chicago.

Preece's general method of calculating the K R of a metallic circuit was by multiplying the total capacity of the line by its total resistance and then dividing by four, since the capacity of an insulated loop is taken as one-fourth of the capacity of the entire length of the line measured against the ground. Even when calculated in this way the K R of the Boston-Chicago conductor line is nearly 54,000.

Lead Sulphate of Copper Cell.—(See Appendix—*Cell, Lead Sulphate of Copper.*)

Lead Sulphate of Zinc Cell.—(See Appendix—*Cell, Lead Sulphate of Zinc.*)

Leads, Double-Wire System for Electric Light — —A term employed for a parallel or multiple system of leads for electric light. (See *Circuit, Parallel. Circuit, Multiple.*)

Leads, Grouping System for Electric Light — —A term sometimes employed for series-multiple circuits. (See *Circuit, Series-Multiple.*)

Leads, Single Wire System for Electric Light — —A term sometimes employed for a circuit in which the current after passing through the lamps is returned by means of the earth or ground.

This is called the single wire system for electric light leads because but a single wire or conductor is employed in the circuit, the return being made through the ground or earth.

Leak, Telegraphic, Resistance of — — The resistance offered by a leak in a telegraphic line or circuit.

Leakance.—A word proposed by Heaviside for leakage conductance.

It will be seen that the proposed word is an abbreviation or contraction for leakage-conductance.

Lease, Way — —A permit obtained from the owner of a property for the erection of poles or other attachments for telephonic or telegraphic lines.

Left-Hand Trolley Switch.—(See Appendix—*Switch, Left-Hand Trolley.*)

Left-Handed Helix.—(See Appendix—*Helix, Left-Handed.*)

Left-Handed Rotation.—(See Appendix—*Rotation, Left-Handed.*)

Left-Handed Spiral.—(See Appendix—*Spiral, Left-Handed.*)

Lever Switch.—(See Appendix—*Switch, Lever.*)

Light, Castor and Pollux — —A term formerly used in place of St. Elmo's fire.

Light Cell.—(See Appendix—*Cell, Light.*)

Light Indicator of Railroad Signal.—(See Appendix—*Indicator, Light, of Railroad Signal.*)

Light Load. — (See Appendix — *Load, Light.*)

Light, Northern — —An aurora borealis.

Lighting, Vacuum-Tube — —Artificial illumination obtained by the passage of electric discharges through vacuum tubes.

A practical system of electric lighting by means of vacuum tubes was not long ago regarded as an impossibility; now, however, through the labors of many distinguished men, especially those of Tesla, such a system, which seems to possess many advantages, bids fair in event of certain difficulties being overcome to become a formidable rival to the incandescent electric lighting.

In a system of vacuum-tube lighting, some source of high alternating potential furnishing from 50,000 to 100,000 volts or more is employed. Such discharges are most readily obtained by means of an alternator and disruptive discharges from condensers in connection with an oil transformer. The oil transformer is employed on account of the high resistance of the oil as a dielectric. One of the most important advantages which vacuum-tube lighting possesses over lighting by means of the ordinary incandescent electric lamp is that it produces a cold light or illumination of the type of glow illumination. (See Appendix—*Illumination, Glow.*)

Lightning Arrester Board.—(See Appendix—*Board, Lightning Arrester.*)

Lightning, Bead — —A form of lightning discharge in which the flash produces a discontinuous line of light, thus causing the discharge to assume a bead-like appearance.

Lightning Tube.—(See Appendix—*Tube, Lightning.*)

Limit, Magnetic — —A term sometimes employed for the temperature at which a magnetic substance loses its magnetism on exposure to heat.

Line, Kapp — —A term proposed, but not generally adopted, for the English unit of magnetic induction.

This term, which defines the lines per square inch instead of per square centimetre, does not harmonize with the C. G. S. system of units, and, therefore, should not be encouraged.

Line, Telegraphic, Charge Current on — —The current produced by the initial rush of electricity into a telegraphic line on the closing of the circuit.

Lines of Magnetization.—(See Appendix—*Magnetization, Lines of.*)

Linear Capacity of Cable.—(See Appendix—*Cable, Linear Capacity of.*)

Linear Density of Charge.—(See Appendix—*Charge, Linear Density of.*)

Linear Insulation of Cable.—(See Appendix—*Cable, Linear Insulation of.*)

Liquid, Quickenig — —A term sometimes applied to a quicking solution. (See *Solution, Quicking.*)

Lithanode.—A name employed for a solid highly conducting block of lead peroxide prepared by a certain process for the plate of a storage cell. (See *Cell, Storage.*)

The word lithanode is properly applied to the product produced by Fitzgerald's process.

Lithotritry, Electro — —A term pro-

posed for a crushing or removing of urinary calculi by means of electrolysis.

Load.—The work thrown upon an electromagnetic system or machine.

The load on a dynamo, for example, means the value of its activity or rate of doing work.

Load Diagram.—(See Appendix—*Diagram, Load.*)

Load, Full — —A term indicating the condition of running with a comparatively large amount of work.

Load, Light — —A term indicating the condition of running with a comparatively small amount of work.

Locomotive, Telfer — —An electric motor by means of which telfer cars are drawn on a telfer line. (See *Telferage.*)

Long-Range Electrometer.—(See Appendix—*Electrometer, Long-Range.*)

Loop Test.—(See Appendix—*Test, Loop.*)

Loss, $C^2 R$ — —A term for the loss of energy in a conductor due to the ohmic resistance offered by the conductor to its passage.

The product $C^2 R$ = activity in watts. In this formula, C, is the current in ampères and R, is the ohmic resistance in ohms, and, when multiplied by the proper factor, it will give the value of the loss in heat units.

Loss, Core, of Transformer — —A loss of energy in the core of a transformer due to hysteresis and Foucault or eddy currents, etc.

Low-Frequency Transformer.—(See Appendix—*Transformer, Low-Frequency.*)

Low-Test Fault.—(See Appendix—*Fault, Low-Test.*)

Luminous Disc-Shaped Discharge.—(See Appendix—*Discharge, Luminous Disc-Shaped.*)

Luminous Interference.—(See Appendix—*Interference, Luminous.*)

M

\mathfrak{M} .—A symbol for magnetic moment.

The defining equation is $\mathfrak{M} = m l$.

m.—An abbreviation for minute, one of the practical units of time.

m.—A symbol for strength of magnetic pole.

The defining equation is $F = \frac{m^2}{L^2}$

m.—An abbreviation for metre, the practical unit of length.

μ .—A symbol for magnetic permeability or inductivity.

The defining equation is $\mu = \frac{\mathfrak{D}}{\mathfrak{H}}$

m².—An abbreviation for square metre, the practical unit of surface.

m³.—An abbreviation for cubic metre, the practical unit of volume.

m. a.—A contraction for milli-ampère. (See *Milli-Ampère*.)

m : s.—An abbreviation proposed for metre-per-second, the practical unit of velocity.

m : s².—An abbreviation proposed for metre-per-second-per-second, the practical unit of acceleration.

M. Current.—(See Appendix—*Current, M.*)

M. P.—A contraction proposed for man-power.

M. S. Current.—(See Appendix—*Current, M. S.*)

Machine, Dynamo-Electric, Arc Lighting — — — A dynamo-electric machine suitable for supplying current to arc lamps.

Arc lights are almost invariably connected to the circuit in series. In such cases the series-wound dynamo is preferable for feeding such circuits. (See *Machine, Dynamo-Electric, Series-Wound*.)

Machine, Dynamo-Electric, Compensating-Alternating — — — A term proposed

for a compensating alternator. (See Appendix—*Alternator, Compensated*.)

Machine, Dynamo-Electric, Direct Current — — — A term sometimes employed in place of continuous current dynamo-electric machine. (See *Machine, Dynamo-Electric, Continuous Current*.)

Machine, Dynamo-Electric, for Electro-Plating — — — A dynamo-electric machine suitable for use in electro-plating. (See *Machine, Dynamo-Electric, Plating, Electro*.)

An electro-plating dynamo-electric machine possesses many advantages over a voltaic battery for the ready production of the current required in electro-plating. By its use the tedious, expensive, and often unhealthy charging of a voltaic battery is entirely dispensed with, since the mere running of a belt over a pulley, and the proper speeding of the machine, is all that is required to furnish a suitable current.

Dynamo-electric machines for electro-plating should be furnished with a device for the purpose of preventing a reversal of the polarity of the dynamo by means of the current produced by the polarization of the electrodes or articles connected with the plating bath. The tendency of this current is of course opposed to that of the current furnished to the bath, and, should the machine be continued in use as a source of current for plating while its polarity is reversed, the metal already deposited on the articles that are being electro-plated will be removed.

In the early history of the art, considerable difficulty was experienced with series-wound machines due to reversals in the polarity of the dynamos, by means of the current sent backwards through the dynamo by the counter E. M. F. of the electro-plating bath, whenever, by reason of a decrease of current strength, or a decrease of the speed of the dynamo, its E. M. F. fell below the counter E. M. F. of the bath.

Weston prevents such a reversal of the polarity of the dynamo by opening the circuit of the machine as soon as the speed of the machine falls below a certain point. He does this by means of the centrifugal force acting on a small quantity of mercury in a small hollow conical-shaped vessel.

Brush first accomplished this same result by means of a shunt which he called a "teaser." His early plating machine containing this device was the prototype of the compound-wound dynamo-electric machine. In it the coils of the field magnets are excited partly by the main current and partly by a current shunting across the brushes of the machine. A machine so constructed possesses the great advantage of rendering the machine self-regulating under certain circumstances. This additional or shunt circuit takes a variety of forms. (See *Machine, Dynamo-Electric, Compound-Wound*.)

The difficulty of reversed polarity has disappeared since the introduction of the shunt or compound-wound dynamo, *i. e.*, a dynamo whose field is wholly or in part excited by a current shunted across the brushes of the armature. In such a machine, even if the E. M. F. falls below the counter E. M. F. of the bath, the current in the shunt field, and therefore the polarity, remains unchanged, and the current reverses only in the armature.

Machine, Dynamo-Electric, Four-Pole — — A term sometimes employed for a dynamo-electric machine in which the field is produced by two separate north poles, and two separate south poles.

Machine, Dynamo-Electric, Incandescent Lighting — — A term sometimes employed for a dynamo-electric machine suitable for furnishing the currents employed for incandescent electric lamps.

For all cases where the incandescent electric lamps are connected to the leads in multiple-arc, or any of its varieties, any machine capable of producing and maintaining a constant potential at its terminals, notwithstanding changes in the load on it, is suitable for use as an incandescent electric-lighting dynamo-electric machine. Compound-wound machines are generally employed for such purposes. (See *Machine, Dynamo-Electric, Compound-Wound*.)

Machine, Dynamo-Electric, Separate-Coil Alternating — — A term sometimes employed for a separate coil alternator. (See Appendix—*Alternator, Separate-Coil*.)

Machine, Dynamo-Electric, Separately Excited Alternating — — A term sometimes employed for separately excited alter-

nator. (See Appendix—*Alternator, Separately Excited*.)

Machine, Dynamo-Electric, Six-Pole — — A term sometimes employed for a dynamo-electric machine in which the field is produced by six poles, *i. e.*, three separate north poles and three separate south poles.

Machine, Dynamo-Electric, Two-Pole — — A term sometimes employed for a dynamo-electric machine in which two poles only are employed for producing the field.

Such a machine is usually called a bi-polar machine.

Machine, Magneto-Electric, Alternating — — An alternating current dynamo-electric machine, the field of which is produced by permanent magnets.

A magneto alternator. (See Appendix—*Alternator, Magneto*.)

Machine, Speeding of — — Obtaining the requisite number of rotations of an armature of a machine per second.

Machines as ordinarily constructed produce their most economical output for practical purposes when a certain speed of rotation has been obtained.

Machines, Dynamo-Electric, Alternating, Parallel Working of — — The working of two or more alternators in parallel. (See Appendix—*Alternators, Parallel Connection of*.)

Machines, Dynamo-Electric, Alternating, Series-Working — — The series connection of two or more alternating dynamo-electric machines. (See Appendix—*Alternators, Series Connection of*.)

Magazine, Magnetic — — A term sometimes employed for a compound magnet. (See *Magnet, Compound*.) (Obsolete.)

Magne-Crystalline Force.—(See Appendix—*Force, Magne-Crystalline*.)

Magne-Electric Induction. — (See Appendix—*Induction, Magne-Electric*.)

Magnet, Choke — — A term proposed, for choking coil. (See *Coil, Choking*.)

The term choking coil would appear to be preferable.

Magnet, Compound — —A term formerly applied to an induction coil with two separate circuits.

The use of this word is inadvisable. The same word is already correctly employed for a magnet formed of a number of separate magnets. (See *Magnet, Compound*.)

Magnet, Deflecting — —The permanent magnet of a magnetometer employed for deflecting a small magnetic needle suspended at a definite distance in order to compare its influence with that of the earth's horizontal magnetic force.

Magnet, Differential, Electro — —A differentially wound electro-magnet. (See Appendix—*Winding, Differential*.)

Magnet, Electro-Compound — —A term formerly applied to an electro-magnet the core of which is wound with two separate wires or conductors.

Magnet, Laminated, Permanent — —A term sometimes employed in place of compound magnet.

Magnet, North Pole of, Proposed A. I. E. E. Definition for — —The pole of a magnet which seeks the geographical north pole.

Magnet, South Pole of, Proposed A. I. E. E. Definition for — —The pole of a magnet which seeks the geographical south pole.

Magnet, Theoretical — —A hypothetical magnet assumed for the purpose of mathematical discussion, as fulfilling the following conditions, namely: An infinitely long and thin, uniformly magnetized bar.

Magnet, Voltaic — —A term sometimes employed for a solenoid or electro-magnetic helix. (See *Solenoid*.)

Magnetic Alternator.—(See Appendix—*Alternator, Magnetic*.)

Magnetic Atmosphere.—(See Appendix—*Atmosphere, Magnetic*.)

Magnetic Bearing.—(See Appendix—*Bearing, Magnetic*.)

Magnetic Compensator.—(See Appendix—*Compensator, Magnetic*.)

Magnetic Disturbance.—(See Appendix—*Disturbance, Magnetic*.)

Magnetic Effluvia.—(See Appendix—*Effluvia, Magnetic*.)

Magnetic Fluid.—(See Appendix—*Fluid, Magnetic*.)

Magnetic Flux Path.—(See Appendix—*Path, Magnetic Flux*.)

Magnetic Helix.—(See Appendix—*Helix, Magnetic*.)

Magnetic Hysteresis.—(See Appendix—*Hysteresis, Magnetic*.)

Magnetic Limit.—(See Appendix—*Limit, Magnetic*.)

Magnetic Magazine.—(See Appendix—*Magazine, Magnetic*.)

Magnetic Phantom.—(See Appendix—*Phantom, Magnetic*.)

Magnetic Shading.—(See Appendix—*Shading, Magnetic*.)

Magnetic Source.— (See Appendix—*Source, Magnetic*.)

Magnetic Spectrum.—(See Appendix—*Spectrum, Magnetic*.)

Magnetic Spiral.— (See Appendix—*Spiral, Magnetic*.)

Magnetic Voltmeter.—(See Appendix—*Voltmeter, Magnetic*.)

Magnetics.—That branch of science which treats of the laws and phenomena of magnetism.

The use of this term should not be encouraged.

Magnetician.—A word proposed for one skilled in the science of magnetism as known.

This word appears to be a good one, but is little used.

Magnetine.—A word formerly employed for the principle of magnetism, or for the imponderable, hypothetical fluid in which magnetic phenomena were assumed to take place.

Magnetisation.—(See *Magnetization*.)

Magnetisation, Back — —(See Appendix—*Magnetization, Back*.)

Magnetisation, Lines of — — (See Appendix—*Magnetization, Lines of*.)

Magnetish.—Possessing the property of magnetism to a limited degree.

This term is a bad one, and its use should be avoided.

Magnetism, Complex-Lamellar, Distribution of — —The distribution of the magnetism of a finite magnet into an infinite number of complex magnetic shells.

Magnetism, Horizontal Intensity of Earth's — —The force which causes a magnetic needle to come to rest in a horizontal position in the earth's field.

The horizontal intensity of the earth's magnetism can be determined by means of a magnetometer. The horizontal intensity at any place is proportional to the square root of the number of oscillations which a needle suspended about a vertical axis performs at that place in a given time, when disturbed from its position of rest in the earth's field.

Magnetism, Total Intensity of Earth's — —The entire force of the earth's magnetism.

The total intensity of the earth's magnetism is equal to the resultant of the horizontal and vertical intensities, or to the quotient of the horizontal intensity by the cosine of the angle of dip.

Magnetism, Remanent — —A phrase sometimes used in place of residual magnetism. (See *Magnetism, Residual*.)

Magnetism, Specific — —A term proposed for the quotient of the magnetic moment of a magnet by its mass.

Magnetism, Vertical Intensity of Earth's — —The force which tends to cause a magnetic needle to assume a vertical position.

The following formula gives the vertical intensity of the earth's magnetism :

$$V = H. \tan. \theta$$

Where V = vertical intensity.

H = the horizontal intensity.

and θ = the angle of dip.

Magnetist.—A magnetician.

The word magnetician is preferable.

Magnetizability.—Possessing the ability of becoming magnetized.

Magnetization, Back — —A term proposed in place of back or backward induc-

tion. (See Appendix—*Induction, Backward*.)

Magnetization, Circular — —The magnetization which exists in a diphas motor in which two alternating magnetic fluxes of equal amplitude are produced in quadrature or at right angles to each other.

Magnetization, Elliptical Rotary — —The magnetization which exists in a diphas motor in which two alternating magnetic fluxes exist out of phase with each other.

Magnetization, Lines of — —A term sometimes employed for lines of magnetic induction.

When lines of magnetic force pass through air, the number of lines of induction are the same as the number of lines of magnetizing force ; when, however, the lines of force pass through iron, the number of such lines of induction is greatly increased.

Magnetizee.—A word proposed to designate a person who believes he is placed under the power of animal magnetism.

Magnetizer.—A word proposed to designate a person who claims to place another under the power of animal magnetism.

Magnetizing Helix.—(See Appendix—*Helix, Magnetizing*.)

Magnetizing Spiral.—(See Appendix—*Spiral, Magnetizing*.)

Magneto-Alternator. — (See *Alternator, Magneto*.)

Magneto-Chemical Cell.—(See Appendix—*Cell, Magneto-Chemical*.)

Magnetod.—A word employed by Reichenbach for the assumed force or principle of animal magnetism.

Magneto-Electric Alternating Machine. —(See Appendix—*Machine, Magneto-Electric Alternating*.)

Magneto-Inductive Capacity.—(See Appendix—*Capacity, Magneto-Inductive*.)

Magnetology.—That branch of science which treats of magnetism.

The word magnetism would appear to be preferable.

Magnetometer, Inclination — —A form of magnetometer suitable for measuring variations in the magnetic inclination at any place.

Magnetometer, Registering Declination — —A form of magnetometer in which the variations of the declination at any place can be automatically registered.

Magnetometer, Variation — —A form of magnetometer suitable for measuring changes in the magnetic variation at any place.

Magneto-Metric.—Of or pertaining to the measurement of magnetic force.

Magnetometry.—That branch of science which treats of the measurement of the strength of magnetic fields.

Magneto-Motor.—(See Appendix—*Motor, Magneto.*)

Magnetophone.—A word sometimes used for a magneto telephone.

Magneto-Tapper.—(See Appendix—*Tapper, Magneto.*)

Man Power.—(See Appendix—*Power, Man.*)

Manual Repeater.—(See Appendix—*Repeater, Manual.*)

Manual Translation.—(See Appendix—*Translation, Manual.*)

Marks, Ripple, Electrical — —Wave marks produced in a fine powder by the discharge of a Leyden jar in its neighborhood.

These ripple marks are due to waves set up in the air by the passage of the discharge.

The same discharge that produces waves in ether also sets up waves in the surrounding air. It can be shown that the same discharge that can excite ether waves 1 kilometre in length can excite waves in the air about 1 millimetre in length.

Matt.—A word employed in electro-plating to designate the appearance presented by an electro-plating of silver in which the deposit is interlaced and closely massed together. (See *Plating, Electro.*)

Matter, Electric — —A term formerly applied to the matter which was believed to

constitute the effluvia formerly assumed to pass off from an electrified body.

Matter, Fourth State or Condition of — —A term sometimes employed for the ultra-gaseous or radiant state of matter. (See *Matter, Radiant or Ultra-Gaseous.*)

Matting, Burglar Alarm — —A matting provided with a number of invisible contacts connected with alarm bells whose circuits are closed by treading on the matting. (See *Matting, Invisible Electric Floor.*)

Maximum Negative Elongation.—(See Appendix—*Elongation, Maximum Negative.*)

Maximum Positive Elongation.—(See Appendix—*Elongation, Maximum Positive.*)

Maximum Starting Current of Motor.—(See Appendix—*Current, Maximum Starting, of Motor.*)

Maynooth Voltaic Cell.—(See Appendix—*Cell, Voltaic, Maynooth.*)

Mechanical Replacement of Disc-Indicator.—(See Appendix—*Indicator, Disc, Mechanical Replacement of.*)

Mechanical Telegraphic Interrupter.—(See Appendix—*Interrupter, Telegraphic, Mechanical.*)

Medication, Cataphoric — —The introduction of drugs or other medicaments into the body through its tissues by the cataphoric action of an electric current. (See *Cataphoresis. Osmose, Electric.*)

Medium, Aelotropic — —A medium which manifests different actions in definite directions; *i. e.*, an eolotropic medium. (See *Medium, Eolotropic.*)

Crystallized bodies are in general notably aelotropic, while amorphous substances are generally isotropic.

An aelotropic substance may be expected to possess different electrostatic elasticity and inductive capacity in different directions.

Melting of Electric Conductor.—(See Appendix—*Conductor, Electric, Melting of.*)

Mereurial Phosphorus.—(See Appendix—*Phosphorus, Mercurial.*)

Metallic Conduction.—(See Appendix—*Conduction, Metallic.*)

Metallic Cross.—(See Appendix—*Cross, Metallic.*)

Metallo-Chromes.—Colors which appear when a salt of lead, such as the acetate, is electrolyzed under peculiar circumstances.

Metallochromes are produced by electrolytic deposits of peroxide of lead in the neighborhood of the anode. When the thickness of the coating, which is deposited on a plate of polished steel, is properly regulated, a series of brilliant colors appear.

Gassiot recommends the following process for obtaining metallochromes.

“Place the polished steel plate in a glass basin containing a clear solution of acetate of lead, and over it a piece of card. A small rim of wood should be placed over the card, and on that a circular copper disc. On contact being made from 5 to 20 minutes, with two or three cells of a small constant battery, the steel plate being connected with the positive electrode, and the copper disc with the negative, the deposit will be effected, and a series of exquisite colors will appear on the steel plate. The colors are films of peroxide of lead thrown down on the surface of the steel, and the varied tints are occasioned by the varying thicknesses of the precipitated film, the light being reflected through them from the metallic surface below. By reflected light every prismatic color is seen; and by transmitted light a series of prismatic colors complementary to the first series appears, occupying the place of the former series.

“The colors are seen in the greatest perfection by placing the plate before a window, and inclining a white sheet of paper at 45 degrees over it.”

Similar colorations are obtained when other substances are electrolytically deposited. Under certain conditions these colorations assume the form of concentric circles, that are sometimes called Nobili's rings.

Nobili's rings are readily obtained by placing a drop of acetate of copper on a silver plate and touching the middle of the drop with a piece of zinc. Under these circumstances prismatically colored rings are formed, that are disposed concentrically around the point of contact of the zinc.

Meteorograph, Electric.—An apparatus for automatically registering various meteor-

ological values, such, for example, as the indications of a barometer or thermometer, the direction and velocity of the wind, or the value of the rainfall.

Meteorology.—That branch of physics which treats of the phenomena of the atmosphere.

Meteorology, Electric — —That branch of meteorology which treats of the electric phenomena of the atmosphere.

Meter, Coulomb — —Any form of apparatus capable of measuring the number of coulombs that pass in a circuit in a given time.

Any form of galvanometer which gives the current in ampères will give the number of coulombs that pass if the time the current is flowing is known. Various forms of electric meters will therefore give the number of coulombs that pass in a circuit. (See *Meter, Electric.*)

Meter, Electrolytic — —An electrochemical meter. (See *Meter, Electro-Chemical.*)

Meter, Quantity — —A coulomb meter.

Meter, Telephonic — —A meter employed for recording the time during which a telephone is in use.

The telephonic meter, as at present constructed, consists essentially of a clock, the pendulum of which is caught by means of a lever connected with the telephone lever. By such means the clock is stopped while the telephone is out of use or is hung on its hook.

Method, Accumulation, for Testing Joints in Electric Cables — —A sensitive method of testing the insulation of a joint, or of a few feet of gutta-percha core, by allowing the leakage of the joint to accumulate through a condenser for a considerable time and then measuring the condenser discharge.

Method of Slow Discharge.—(See Appendix—*Discharge, Slow, Method of.*)

Mho, Proposed A. I. E. E. Definition for — —A name proposed for the practical unit of conductivity.

A unit of electrical conductance of the value of 10^{-9} absolute units; or, in other words, having a value equal to the reciprocal of the ohm.

This name for the practical unit of electrical conductance was proposed by a Sub-Committee of the American Institute of Electrical Engineers on Provisional Programme of the International Electrical Congress, held in Chicago, U. S. A., in 1893, on the occasion of the World's Columbian Exposition.

Mhometer.—An instrument for measuring the value of conductance in mhos. (See *Conductance. Mho.*)

Micanite.—A name sometimes given to a variety of insulating material made from pure mica bound together by some cementing material.

Micro-Ohm.—The millionth of an ohm.

Microphone, Plastic-Circuit — —A microphone in which the ordinary variable contact is replaced by a plastic material of low conducting power.

The plastic-circuit microphone is the invention of Clammond. In it the ordinary powder forming the loose contact is obtained by means of a plastic material composed of a mixture of a good conducting substance with some plastic non-conducting material.

The advantage claimed for the plastic-circuit telephone transmitter is that it has a much greater range of operation than the ordinary contact microphone, being able to transmit either faint or loud tones with equal distinctness.

Migration of Ions.—(See Appendix—*Ions, Migration of.*)

Mile, Ohm — —The number obtained by multiplying the weight of 1 mile of wire of a given substance by its resistance.

The ohm mile of a given substance is the mass of a mile of wire of that substance having the resistance of an ohm.

Milli-Ammeter.—A milli-ampère meter.

Milli-Ampère Meter.—(See *Meter, Milli-Ampère.*)

Mining, Electric — —Carrying on the various operations of mining by means of electric power.

Electricity has been successfully employed in mining for the driving of percussion or rotary drills, for electric haulage, for pumping, and for purposes of communication, ventilation, power and artificial lighting.

Minus Charge.—(See Appendix—*Charge, Minus.*)

Molecular Decomposition.—(See Appendix—*Decomposition, Molecular.*)

Molecular Voltaic Couple.—(See Appendix—*Couple, Molecular Voltaic.*)

Monad Atom.—(See Appendix—*Atom, Monad.*)

Monochord.—A single stretched wire for measuring the relative number of vibrations produced by different musical notes.

The instrument takes the name monochord, from the fact that it consists, practically, of a single chord stretched between two points of support over a resonant case, and provided with means for suitably adjusting its tension so as to produce, when vibrating as a whole, a note of a given musical pitch. When it is required to determine the relative number of vibrations existing between the note which the monochord produces and some other note, a sliding bridge is placed in some intermediate part of the wire so as to cut off a part of its length.

When the length of the original wire has been shortened by means of a sliding bridge, so that it produces a higher note whose pitch is to be compared with that of the wire vibrating as a whole, the relative number of vibrations are then inversely proportional to the lengths of the two wires.

Mop, Polishing — —A disc formed of circular pieces of calico, felt, or similar soft material mounted on a shaft and employed, when put in rapid rotation, for polishing articles so as to prepare their surfaces for electro-plating. (See *Plating, Electro.*)

For use, mops are charged with fine polishing material; as, rouge, tripoli, etc.

Mopped.—Polished by the action of a mop. (See Appendix—*Mop, Polishing.*)

Morse Push.—(See Appendix—*Push, Morse.*)

Morse Tapper.—(See Appendix—*Tapper, Morse.*)

Motion, Electrostatic — —Motion produced by means of an electrostatic field somewhat similar to the motion produced by means of a magnetic field.

Electrostatic motion may be produced by varying electrostatic fields placed at right angles to each other. When the force varies in accordance with the sine law, and the difference in phase varies by only 90 degrees, a uniform tendency to rotation is produced.

Motion, Harmonic — —A term sometimes employed in place of simple-harmonic motion. (See *Motion, Simple-Harmonic*.)

Motion, Periodic — —A term sometimes employed in place of simple-periodic motion. (See *Motion, Simple-Periodic*.)

Motor, Constant-Potential — —A motor designed for operation by means of a constant potential current.

Where the motor is to be operated at a constant speed, or by a constant-potential circuit, such, for example, as an incandescent lighting circuit, it is generally made a plain, shunt-wound motor.

Motor, Diphas — —A motor which requires for its operation two diphas currents.

The armature of such a motor is always wound either with two separate circuits, or has two separate connections to the same common winding.

This term would appear preferable to the term two-phase motor.

Motor, Dynamo — —A constant current transformer or dynamotor. (See Appendix—*Dynamotor*.)

Motor, Efficiency of Electric — —The watts delivered at the motor pulley, divided by the watts supplied.

Motor, Electric Street Railway, Bucking of — —(See Appendix—*Bucking*.)

Motor, Electrostatic — —A motor driven by means of the induction of two varied electrostatic fields at right angles to each other.

Generally, a motor driven by the action of electrostatic fields.

Motor, Idle Wire of — —(See Appendix—*Wire, Idle, of Armature of Motor*.)

Motor, Induction — —A motor in which the magnetic field is produced entirely by the

working current, as distinguished from a motor in which the field magnets are independently maintained.

An induction motor consists essentially of coils of wire and laminated iron discs so related to one another that the currents in the moving parts are induced by currents in the stationary parts.

Motor, Magneto — —A term formerly employed for a voltaic battery coupled in parallel.

The current furnished by such a battery being capable, when employed with suitable electromagnets, to produce powerful magnetism, was called a magneto-motor. This word is generally used as below.

Motor, Magneto — —A motor whose field is produced by permanent magnets.

Motor-Man.—A word generally applied to the person who operates the motor car of street railway systems.

Motor, Multiphas — —A term sometimes employed in place of polyphase motor. (See Appendix—*Motor, Polyphase*.)

Motor, Polyphase — —A motor operated by means of polyphase currents.

Motor, Polyphase, Unsymmetrical — —An unbalanced polyphase motor; *i. e.*, a motor where one circuit carries a greater load than the other circuit or circuits.

Motor, Single-Phase — —A uni-phase motor.

The term uni-phase is preferable.

Motor, Synchronous, Self-Starting — —A motor of the synchronous type that is capable of self-starting.

Motor, Three-Phase — —A tri-phase motor. (See Appendix—*Motor, Tri-Phase*.)

The term tri-phase motor would appear to be preferable.

Motor, Tri-Phase — —A motor which requires for its operation three tri-phase currents.

The armature of such a motor is always wound either with three separate circuits or has three separate connections to a common winding.

Motor, Two-Phase — —A diphas motor. (See Appendix—*Motor, Diphas*.)

The term diphas motor would appear to be preferable.

Motor, Uni-Phase — — A motor which requires for its operation a simple alternating current; *i. e.*, a current which is uni-phase.

The term uni-phase is preferable to the term single-phase.

Mounting of Filament.—(See Appendix *Filament, Mounting of*.)

Multi-Phase Alternator.—(See Appendix — *Alternator, Multi-Phase*.)

Multi-Phase Motor.—(See Appendix — *Motor, Multi-Phase*.)

**Multiple Auto-reversible Tele-radio-
phone.**—(See Appendix — *Tele-radiophone, Auto-reversible or Multiple*.)

Multiple-Lightning Flash.—(See Appendix—*Flash, Multiple-Lightning*.)

Multiple-Parallel Circuit.—(See Appendix—*Circuit, Multiple-Parallel*.)

Multiplex Telegraph.—(See Appendix—*Telegraph, Multiplex*.)

Multiplex Telephony.—(See Appendix—*Telephony, Multiplex*.)

Multiplier, Astatic — — A term sometimes employed for an astatic galvanometer. (See *Galvanometer, Astatic*.)

Multiplier, Dynamic — — A term formerly applied to a self-induction coil. (See Appendix—*Coil, Induction, Self*.)

Multiplier, Electro-Magnetic — — A term sometimes employed for Sweigger's Multiplier. (See *Multiplier, Sweigger's*.)

Municipal System of Incandescent Electric Lighting.—(See Appendix—*System, Municipal, of Electric Lighting*.)

Mutually Induced Currents.—(See Appendix—*Currents, Mutually Induced*.)

N

n.—A symbol sometimes employed for frequency.

Natural Period.—(See Appendix—*Period, Natural*.)

Needle, Drift of — — The failure of the needle of a galvanometer to remain at its zero point when no current is passing through its coils, usually due to variation in the magnetic condition of the needle, or to variation in the torsion of the suspending fibre, local causes, etc.

Needle Telegraph.—(See Appendix—*Telegraph, Needle*.)

Needle, Vertical Magnetic — — A term sometimes employed for a dipping needle. (See *Needle, Magnetic, Dipping*.)

Negative Electrification.—(See Appendix — *Electrification, Negative*.)

Negative Fluid.—(See Appendix—*Fluid, Negative*.)

Negative Spark.—(See Appendix—*Spark, Negative*.)

Neutral Zone of Electrically Charged Insulated Conductor.—(See Appendix—*Zone, Neutral, of Electrically Charged Insulated Conductor*.)

Neutral Zone of Magnet.—(See Appendix—*Zone, Neutral, of Magnet*.)

Nipple on Negative Carbon.—A small projection formed at the end of the negative carbon directly opposite the positive carbon of a voltaic arc that has been established for some little time.

The nipple is formed at the end of the negative carbon directly opposite the crater in the opposing end of the positive carbon by the deposition of volatilized carbon from the positive electrode. The material of the nipple is pure graphite or plumbago.

If the ends of the carbons, that are thrown away from an electric arc lamp on trimming the lamp, be examined, they will be found to possess either a small crater or a small projection or nipple at their burned end.

Either of these ends, but especially the nipple at the negative carbon, is formed of pure graphite sufficiently soft to be readily used for some considerable time as a lead pencil.

Node.—A point of comparative rest in a vibrating body.

Since the position of an anti-node for a fundamental tone may be the position of the node for one of its harmonics, it is clear that the nodes are often necessarily only points of relative rest.

Non-Automatic Repeater.—(See Appendix—*Repeater, Non-Automatic.*)

Non-Ferrie Inductance.—(See Appendix—*Inductance, Non-Ferrie.*)

Non-Polar Transformer.—(See Appendix—*Transformer, Non-Polar.*)

Northern Light.—(See Appendix—*Light, Northern.*)

O

o.—An abbreviation sometimes used for ohm, the practical unit of electric resistance.

ω .—A symbol sometimes used for angular velocity.

The defining equation is $\omega = \frac{V}{L}$

o: cm.—An abbreviation proposed for ohm-centimeter, the practical unit of resistivity.

Oersted, Proposed A. I. E. E. Definition for — — A name proposed for the practical unit of magnetic reluctance.

A unit of magnetic reluctance having a value of one absolute unit.

This name was proposed by a Sub-Committee of the American Institute of Electrical Engineers on Provisional Programme for the International Electrical Congress, held in Chicago, U. S. A., in 1893, on the occasion of the World's Columbian Exposition.

Ohm, B. A. — — A resistance of 14.4521 grammes of mercury in the form of a column of uniform cross-section (one square millimetre) and 104.8 centimetres in height at 0 degree C.

The above value of the ohm was adopted as the unit of the British Association at its meeting held in Edinburgh in August, 1892.

Ohm, International — — The value of the international ohm adopted at the Chicago Congress of 1893, as being the resistance column based upon the ohm equal to 10^9 units of resistance of the C. G. S. system of electro-magnetic units, and is represented by the resistance offered to an un-

varying electric current by a column of mercury at the temperature of melting ice 14.4521 grammes in mass, of a constant cross sectional area, and of the length of 106.3 centimetres.

Ohm Mile.—(See Appendix—*Mile, Ohm.*)

Ohm, Proposed A. I. E. E. Definition for — — The resistance offered at the temperature of melting ice by a column of mercury, 14.4521 grammes in mass, of a constant cross-sectional area and of a length of 106.3 centimetres.

One-Way Door Trigger.—(See Appendix—*Trigger, One-Way Door.*)

Open-Circuit Transformer.—(See Appendix—*Transformer, Open-Circuit.*)

Opposing Electromotive Force.—(See Appendix—*Force, Electromotive, Opposing.*)

Optical Galvanometer.—(See Appendix—*Galvanometer, Optical.*)

Oscillator, Hertz's — — A term sometimes employed for two insulated metallic plates, to which are attached metallic rods, terminated by rounded knobs or balls separated by an air gap or air space, through which a disruptive discharge passes.

The metallic plates represent the opposite coating of a Leyden jar. When employed as Hertz's oscillator each plate is connected to the terminal of a Ruhmkorff coil, and at each discharge electrical surgings are produced, which cause waves to radiate from the plates into the surrounding ether.

Oscillator, Hertz's Axial — — A term sometimes employed for Hertz's linear oscil-

lator. (See Appendix—*Oscillator, Hertz's Linear.*)

Oscillator, Hertz's Linear — — A form of Hertz's oscillator in which a straight or linear conductor is employed instead of a plate as in the ordinary oscillator. (See Appendix—*Oscillator, Hertz's.*)

According to Lodge, a thunder cloud connected to the earth by means of a lightning rod forms a linear oscillator.

Out-Put.—The useful energy given out by a machine.

The out-put is generally taken in connection or in comparison with the in-put. When the useful or available electric energy of any source is

divided by the total electric energy, the value of a ratio, called the efficiency, is obtained. In this case the out-put, when divided by the total in-put, gives the efficiency. (See *Efficiency, Electric.*)

Oven, Baking, Electrical — — An electrically heated baking oven.

Almost any form of baking oven can be heated by means of electric heaters suitably placed therein.

Overflow of Leyden Jar.—(See Appendix—*Jar, Leyden, Overflow of.*)

Overlap Test.—(See Appendix—*Test, Overlap.*)

Over-Maximal Contraction.—(See Appendix—*Contraction, Over-Maximal.*)

P

P.—A symbol proposed for power.

The defining equation is $P = \frac{W}{T}$

P.—A symbol proposed for electric power.

The same symbol is proposed for mechanical power.

The defining equation is $P = C E$.

p.—A symbol proposed for pressure.

The defining equation is $p = \frac{F}{S}$

Φ .—A symbol employed for flux of magnetic force.

The defining equation is $\Phi = \mathfrak{B} \times S$.

Pacinotti Teeth.—(See Appendix—*Teeth, Pacinotti.*)

Page Effect.—(See Appendix—*Effect, Page.*)

Pair, Thermo — — A thermo couple. (See *Couple, Thermo-Electric.*)

Pair, Thermo-Electric — — A term sometimes employed in place of thermo-electric couple. (See *Couple, Thermo-Electric.*)

Pair, Voltaic — — A term sometimes employed in place of voltaic couple. (See *Couple, Voltaic.*)

Pan, Backing — — A pan in which the copper shell of an electrolytic cell is placed, in order to receive its backing of type metal.

When the copper shell has been placed in the backing-pan, for the purpose of receiving its backing of type-metal, it has its back covered with sheets of tin-foil. It is then placed along with the backing-pan in the melting-pot, a pot filled with melted type-metal, on which it is permitted to float until the covering of tin-foil is melted. It is now removed and placed on a level table where the molten metal from the melting pot is poured over it until a layer of the required thickness is obtained.

Pan-Telephone.—(See Appendix—*Telephone, Pan.*)

Parallel-Arc Circuit.—(See Appendix—*Circuit, Parallel-Arc.*)

Parallel Connection of Alternators.—(See Appendix—*Alternators, Parallel Connection of.*)

Parallel Working of Alternating Dynamo-Electric Machines.—(See Appendix—*Machines, Dynamo-Electric, Alternating, Parallel Working of.*)

Paramagnetized.—Endowed with paramagnetic properties. (See *Paramagnetism.*)

Passive Resistance.—(See Appendix—*Resistance, Passive.*)

Path, Magnetic Flux — —The path or circuit taken by the lines of magnetic force or flux.

Pear Push. — (See Appendix — *Push, Pear.*)

Peltier's Cross.—(See Appendix—*Cross, Peltier's.*)

Pencil, Carbon — —A term sometimes employed for a carbon rod.

A rod or cylinder of carbon, as distinguished from a plate.

Pendant Socket.—(See Appendix—*Socket, Pendant.*)

Pendulum, Electric — —A term sometimes employed for a pith ball electroscope, so arranged as to move to-and-fro like an ordinary pendulum.

This use of the term is to be avoided, since the word, as primarily employed, signifies either a pendulum driven by electric impulses, or a pendulum so arranged as to produce timed impulses.

The term electroscopic or electrostatic pendulum would appear preferable. (See *Pendulum, Electric.*)

Pentad Atom.—(See Appendix — *Atom, Pentad.*)

Percentage Conductivity of Wire.—(See Appendix — *Conductivity, Percentage, of Wire.*)

Period.—The interval of time between two successive passages of a vibration through a given point of its path taken in the same direction.

Period, Natural — —The period of harmonic frequency which brings it to the same value as that of the fundamental frequency.

The natural period, according to Lodge, is represented by the following formula.

$$T = 2\pi \sqrt{LC} \times 10^{-3}$$

Where T = the period in seconds.

L = the coefficient of self-induction in henries.

C = the capacity in micro-farads.

The natural period can be varied either by varying the self-induction of the circuit or by varying its capacity.

Period, Variable, of Telegraph Line — —The time required for a current in a telegraph line to reach a constant strength after the circuit through it is closed.

Periodic Motion.—(See Appendix—*Motion, Periodic.*)

Periodicity of Alternation.—(See Appendix—*Alternation, Periodicity of.*)

Permanent Laminated Magnet.—(See Appendix — *Magnet, Laminated, Permanent.*)

Permanent Telegraphic Signal.—(See Appendix — *Signal, Telegraphic, Permanent.*)

Permeation.—A word sometimes employed for the number of lines of magnetic force per square centimetre.

Permittance.—A word proposed for dielectric capacity. (See Appendix—*Capacity, Specific Dielectric.*)

Electrostatic induction takes place between the two coatings of a condenser, or between two copper conductors across the dielectric between them. Dielectrics differ greatly in their ability to permit this influence to pass through them, and this difference has been called the dielectric capacity, the specific inductive capacity, the inductive capacity, or the permittance. (See *Capacity, Specific Inductive.*)

Permittivity.—A word sometimes employed for specific permittance. (See Appendix—*Permittance.*)

Phantom, Magnetic — —A term sometimes employed for magnetic figures. (See *Figures, Magnetic. Field, Magnetic.*)

Phantom Streams. — (See Appendix — *Streams, Phantom.*)

Phase.—The fractional part of a period which has passed since a vibrating body last passed through the extreme point of its path in the positive direction.

Phase Angle.—(See Appendix—*Angle, Phase.*)

Phase Windings. — (See Appendix—*Windings, Phase.*)

Phenomena.—Plural of phenomenon.

Phonogram.—A dispatch transmitted by means of a telephone.

The word phonogram corresponds to the word telegram.

This word is also used for the record produced by a phonograph.

Phonoplex Telegraph.—(See Appendix—*Telegraph, Phonoplex.*)

Phosphorescent Lamp.—(See Appendix—*Lamp, Phosphorescent.*)

Phosphorus, Mercurial — —A term employed by Hawksbee in 1795 for the light produced by the motion of a column of mercury in an exhausted tube.

The light so produced is due to electricity caused by the friction of the mercury against the walls of the tube. Such a light is often seen in the Torricellian vacuum which exists in the space above the mercurial column in a barometer tube.

Photo-Electric Alarm.—(See Appendix—*Alarm, Photo-Electric.*)

Photo-Electric Impulsion Cell.—(See Appendix—*Cell, Photo-Electric Impulsion.*)

Photometer, Spectro — —A form of photometer suitable for measuring the relative intensities of lights of different qualities.

A spectro-photometer consists essentially of means by which the two parallel beams of light that are to be compared are passed side by side through the same prism. The field is then limited to a single color, and the respective intensities of the two lights as regards this particular character of radiation are then compared.

Photo-Micrography, Electric — —The art of photographing microscopic images by means of the electric light.

Physiologist, Electro — —One skilled in the art of electro-physiology. (See *Physiology, Electro.*)

Pins, Core, of Magnet — —Small pins of copper or other non-magnetic material placed in the cores of an electro-magnet at its poles for the purpose of preventing sticking.

Planer, Electric Deck — —An electrically driven rotary cutter or planer, adapted for the ready planing of the deck of a ship.

Fig. 579 shows an electric deck planer. The rotary cutter revolves at some three thousand

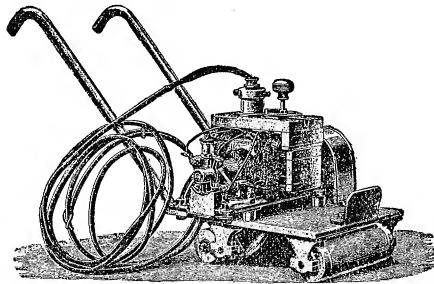

Fig. 579. An Electric Deck Planer.

revolutions per minute, and is so arranged as to be readily adapted for a varying depth of cut.

Plastic-Circuit Microphone.—(See Appendix—*Microphone, Plastic-Circuit.*)

Plates, Exhausted, of Storage Cell — —A phrase employed to characterize the condition of the plates of a storage battery when they have furnished all the current they are capable of producing without being injured. (See *Plates of Secondary or Storage Cell, Forming of.*)

Plates, Field — —A term sometimes applied to the plates of tin-foil, on a Töppler-Holtz influence machine, which act as inductors. (See *Machine, Töppler-Holtz.*)

Plates, Formed, of Storage Cell — —A phrase employed to characterize the condition of the plates of a new storage battery when they have been prepared for regular service by a preliminary process of charging, or charging and discharging. (See *Plates of Secondary or Storage Cell, Forming of.*)

Plating Trough. — (See Appendix—*Trough, Plating.*)

Plug, Attachment — —A plug for attaching and connecting a flexible cord to any lamp socket or receptacle.

Plus Charge.—(See Appendix—*Charge, Plus.*)

Pocket Galvanometer.—(See Appendix—*Galvanometer, Pocket.*)

Point, Indifferent — —A term sometimes employed for the neutral point of a magnet. (See *Line, Neutral, of a Magnet.*)

Point, Smashing, of Incandescent Electric Lamps — —The point in the life of an incandescent electric lamp at which it is said to be more economical to replace it by a new lamp than it is to keep it any longer in use.

The life of an incandescent electric lamp can be preserved for many thousand hours. It is claimed, however, that, so far as economy is concerned, it is more economical after a certain number of hours burning to replace it by another than it is to continue it any longer in use. This conclusion, however, is by no means generally accepted.

The length of life will, of course, depend on the make of the lamp and the potential to which it has been exposed. Cases, however, may frequently arise where it will be more economical to use the lamp under an increased difference of potential than to cease using it.

Polar Aurora.—(See Appendix—*Aurora, Polar.*)

Polar Transformer.—(See Appendix—*Transformer, Polar.*)

Polarization Battery.—(See Appendix—*Battery, Polarization.*)

Polarization, Gas — —A term sometimes employed for that form of polarization which is due to the collection of a gas, generally hydrogen, on the negative plate. (See *Cell, Voltaic, Polarization of.*)

Polarized Indicator.—(See Appendix—*Indicator, Polarized.*)

Pole Indicator.—(See Appendix—*Indicator, Pole.*)

Pole, Magnetic, Blue — —A term sometimes employed for that pole of a magnet which points approximately towards the geographical south pole.

The natural confusion arising from this non-descriptive term is still further increased by the fact that some writers use the word blue-pole for

the pole which points towards the geographical north pole.

Pole, Magnetic, Red — —A term sometimes employed for the pole of a magnet which points approximately towards the geographical north pole.

Sometimes used in opposite sense. (See Appendix—*Pole, Magnetic, Blue.*)

Pole, Magnetic, Unmarked — —A term sometimes employed for the south pole of a magnet.

Pole, Resultant Magnetic — —A term sometimes employed for a consequent pole. (See *Pole, Consequent.*)

Polishing Bob.—(See Appendix—*Bob, Polishing.*)

Polishing Mop.—(See Appendix—*Mop, Polishing.*)

Polyphase Apparatus.—(See Appendix—*Apparatus, Polyphase.*)

Polyphase Armature.—(See Appendix—*Armature, Polyphase.*)

Polyphase Currents.—(See Appendix—*Currents, Polyphase.*)

Polyphase Generator.—(See Appendix—*Generator, Polyphase.*)

Polyphase Motor.—(See Appendix—*Motor, Polyphase.*)

Polyphase Working.—(See Appendix—*Working, Polyphase.*)

Polyphased Alternating Currents.—(See Appendix—*Currents, Polyphased, Alternating.*)

Positive Electrification.—(See Appendix—*Electrification, Positive.*)

Positive Fluid.—(See Appendix—*Fluid, Positive.*)

Positive Spark.—(See Appendix—*Spark, Positive.*)

Potash Brush.—(See Appendix—*Brush, Potash.*)

Potential, Scalar — —A potential possessing magnitude and sign without directive signification, as distinguished from a vector potential, which possesses both direction and

magnitude. (See Appendix—*Potential, Vector*.)

Potential, Vector — —A potential possessing directive properties and one that may be derived by the process of summation from vectors, or elementary directed quantities, as opposed to a scalar potential, which possesses undirected magnitude. (See Appendix—*Potential, Scalar*.)

Potentiometer, Alternating Current — —A form of potentiometer designed for measuring the differences of potential in alternating current circuits.

Power Factor.—(See Appendix—*Factor, Power*.)

Power, Man — —A unit of power equal to $\frac{1}{10}$ horse-power, or about $74\frac{1}{2}$ watts.

Pressure, Electric — —A term sometimes loosely employed for difference of potential or electromotive force. (See *Potential, Difference of*.)

The terms potential difference and electromotive force are preferable terms. The use of the term electric pressure can well be abandoned. The term electric pressure, however, is much to be preferred to the very objectionable term electric tension, or difference of tension.

Primary Cell. — (See Appendix—*Cell, Primary*.)

Primary Electric Clock.—(See Appendix—*Clock, Primary Electric*.)

Primary Electric Heater.—(See Appendix—*Heater, Primary Electric*.)

Primary Spiral of Induction Coil.—(See Appendix—*Spiral, Primary, of Induction Coil*.)

Process, Building, for Moulds of Electrotypes — —A process for bringing up the blank spaces in the mould of an electrotype by the use of wax, melted by a building iron—the high places thus built up becoming depressions in the finished plate.

Process, Coking, for Filament of Incandescent Electric Lamp — —A process

for converting the carbon of an incandescent filament into coke, by subjecting it, while in a vacuum, to the prolonged heating action of a powerful electric current. (See Appendix—*Filament, Coked*.)

Process, Quicking — —A term employed in electro-plating for a process by means of which an article that is to be electro-plated with silver, is previously coated with a layer of mercury by dipping it into a quicking solution, *i. e.*, a solution of salt of mercury. (See *Solution, Quicking*.)

Process, Stopping-Off — —A process employed in electro-plating by means of which an article which is to be electro-plated on portions only of its surface with one metal, and on other portions with another metal, is first completely covered by an electro-plating of the cheaper metal, and is then stopped-off, by covering with a coating of non-conducting varnish such portions only of its surface as are not to receive the deposit of the dearer metal. (See *Stopping-Off*.)

Process, Stopping-Out — —A process employed in electrotyping by means of which those parts of an electrotype mould that are not to be copied in the electrotype are covered with clean hot wax.

The stopping-out process is similar to the stopping-off process in electro-plating. Wherever the black lead or plumbago surface is covered with clean wax, the copper fails to be deposited.

Proposed A. I. E. E. Definition for Impressed Electromotive Force.—(See Appendix—*Force, Electromotive, Impressed, Proposed A. I. E. E. Definition for*.)

Proposed A. I. E. E. Definition for Gauss. —(See Appendix—*Gauss, Proposed A. I. E. E. Definition for*.)

Proposed A. I. E. E. Definition for Henry.—(See Appendix—*Henry, Proposed A. I. E. E. Definition for*.)

Proposed A. I. E. E. Definition for Inductivity. —(See Appendix—*Inductivity, Proposed A. I. E. E. Definition for*.)

Proposed A. I. E. E. Definition for Mho.—(See Appendix—*Mho, Proposed A. I. E. E. Definition for.*)

Proposed A. I. E. E. Definition for Mutual Inductance.—(See Appendix—*Inductance, Mutual, Proposed A. I. E. E. Definition for.*)

Proposed A. I. E. E. Definition for North Pole of Magnet.—(See Appendix—*Magnet, North Pole of, Proposed A. I. E. E. Definition for.*)

Proposed A. I. E. E. Definition for Oersted.—(See Appendix—*Oersted, Proposed A. I. E. E. Definition for.*)

Proposed A. I. E. E. Definition for Ohm.—(See Appendix—*Ohm, Proposed A. I. E. E. Definition for.*)

Proposed A. I. E. E. Definition for Polyphase Alternating Current.—(See Appendix—*Current, Polyphase Alternating, Proposed A. I. E. E. Definition for.*)

Proposed A. I. E. E. Definition for Reluctivity.—(See Appendix—*Reluctivity, Proposed A. I. E. E. Definition for.*)

Proposed A. I. E. E. Definition for Self-Inductance.—(See Appendix—*Inductance, Self, Proposed A. I. E. E. Definition for.*)

Proposed A. I. E. E. Definition for South Pole of Magnet.—(See Appendix—*Magnet, South Pole of, Proposed A. I. E. E. Definition for.*)

Proposed A. I. E. E. Definition for Triphase Alternating Current.—(See Appendix—*Current, Triphase Alternating, Proposed A. I. E. E. Definition for.*)

Proposed A. I. E. E. Definition for Volt.—(See Appendix—*Volt, Proposed A. I. E. E. Definition for.*)

Proposed A. I. E. E. Definition for Watt.—(See Appendix—*Watt, Proposed A. I. E. E. Definition for.*)

Proposed A. I. E. E. Definition for Weber.—(See Appendix—*Weber, A. I. E. E. Definition for.*)

Protection, Conduction Lightning — —
—The protection of any instrument from the passage of a current due to lightning around its coils, and so disturbing the magnetism of the needle.

Protection, Insulation Lightning — —
—The protection of any instrument from the jumping of a spark across it from layer to layer.

Protective Action.—(See Appendix—*Action, Protective.*)

Protective Throw. — (See Appendix—*Throw, Protective.*)

Protector, Cage, for Lightning Discharges — —
—A term sometimes employed for protecting sheaths for lightning discharges. (See *Sheath, Protective.*)

The method consists essentially in surrounding the body to be protected by conducting wires in the form of a cage.

Protector, Conduction Lightning — —
—A lightning protector by means of which a current is prevented from passing around the coil of a galvanometer or other needle instrument, and thus disturbing the magnetism of the needle.

Protector, Insulation Lightning — —
—A lightning protector by means of which a discharge is prevented from jumping across the coil of an instrument from layer to layer, and thus damaging the insulation.

Pull Bell, Circuit Closer for — —
—A device suitable for attachment to a mechanical door pull, so as to make an electrical contact for the ringing of an electric bell, without preventing the original bell from being operated by the mechanical pull.

Pull-Off, Double Curve — —
—In a system of electric street railways a hanger supported by a lateral strain in opposite directions, used generally at the ends of both single and double curves and at intermediate points on double track curves.

A double curve hanger.

Pull-Off, Single Curve — —
—In a system of electric street railways a hanger supported

in one direction by a lateral strain except at the ends and on the inside curve of double tracks.

A single curve hanger.

Puncturation, Electro — — A term proposed for electro-puncture.

Electro-puncture would appear to be the preferable term. (See, *Puncture, Electro.*)

Push, Double-Contact — — A push provided with two contacts, so arranged that the pressure of the push opens one contact and closes the other.

Push, Morse — — A term sometimes employed in place of double-contact push. (See Appendix—*Push, Double-Contact.*)

Push, Pear — — A pear-shaped push

provided for attachment to a flexible conducting cord.

Push, Sounder — — An apparatus, consisting of a push so combined with a sounder as readily to enable the one pushing it to know whether a distant bell has rung or not on the depression of the push button.

Push Switch.—(See Appendix—*Switch, Push.*)

Pyro-Electric Crystal.—(See Appendix—*Crystal, Pyro-Electric.*)

Pyrogravure.—A process for the decoration of wood, copper or glass by the burning action of an electrically or otherwise heated tool.

Q

Q.—A symbol used for quantity of electricity.

The defining equation is $Q = CT$.

Quad.—An abbreviation sometimes employed for a unit of self-inductance. (See *Quadrant.*)

The same abbreviation is also employed for quadruplex, but the context will generally prevent any confusion.

Quadmeter.—A secohmmeter. (See *Secohmmeter.*)

Quadrantal Deviation of Mariner's Compass.—(See Appendix—*Deviation, Quadrantal, of Mariner's Compass.*)

Quadruplex Telegraph.—(See Appendix—*Telegraph, Quadruplex.*)

Quality of Radiation.—(See Appendix—*Radiation, Quality of.*)

Quantity Meter.—(See Appendix—*Meter Quantity.*)

Quick Break.—(See Appendix—*Break, Quick.*)

Quick-Break Switch.—(See Appendix—*Switch, Quick-Break.*)

Quickened.—A term employed in electroplating for a surface which has been prepared for the reception of a deposit of silver, by dipping the article into a quickening liquid. (See *Solution, Quickening.*)

Quickening Liquid.—(See Appendix—*Liquid, Quickening.*)

Quickening Solution.—A quicking solution. (See *Solution, Quickening.*)

Quicking Process.—(See Appendix—*Process, Quicking.*)

R

R.—A symbol used for resistance.

The defining equation is $R = \frac{E}{C}$

℔.—A symbol proposed for magnetic resistance or reluctance.

The defining equation is $\mathfrak{R} = \nu \frac{L}{S}$

ρ .—A symbol used for specific electrical resistance or reluctivity.

The symbol ν has been proposed for this quantity by Hospitalier.

R. M. S. Current.—(See Appendix—*Current, R. M. S.*)

Raad.—A name formerly given by the

Arabians to the torpedo or electrical ray. (See *Torpedo, Electric. Ray, Electric.*)

Radial Current.—(See Appendix—*Current, Radial.*)

Radian.—Unit angle.

An angle such that its circular arc is equal in length to its radius.

Its value in degrees is approximately $57^{\circ} 17' 45''$.

The radian is not employed in practical applications, since the degree is the unit angle in ordinary use, but in mathematics angles are nearly always discussed in terms of the radian.

Radian Per Second.—Unit angular velocity of a rotating body.

Radiation, Efficiency of — — A term sometimes employed to represent the ratio of the non-luminous to the luminous radiation in the case of a body emitting light and heat.

The efficiency of the ordinary sources of artificial light is very low. The efficiency of the radiation of the firefly or glow-worm is very high, practically all its radiation belonging to the luminous type.

Radiation, Electric — — The transference of electric energy by means of waves set up in the surrounding ether.

During the oscillatory discharge of a Leyden jar, or, in general, during any disruptive discharge, the electricity surges or rushes to and fro, sending out or radiating its energy into the surrounding ether by means of waves.

It does this until all its energy is either directly dissipated in this manner, or is converted into heat in the conductor, which is afterwards dissipated as heat-waves.

The lengths of the waves thus sent out into space by means of direct radiation of the electrical energy depend on a variety of circumstances, the most important of which are :

(1.) On the capacity of the condensers.

(2.) On the self-induction of the radiating system.

Radiation, Intensity of — — The ratio existing between the amount or quantity of radiation and the surface.

Radiation, Quality of — — Variations in the radiation due to differences, both in the

various wave lengths present and in the polarization.

Radiation, Selective — — Radiation limited to waves of a particular wave length.

The character of the radiation depends.

(1.) On the nature of the body.

(2.) On the condition of its surface.

(3.) On the temperature.

Langley has shown that in the case of a luminous body the proportion existing between the visible radiation and the invisible radiation varies greatly in different cases. In the case of a gas flame, 2.4% of the radiation is luminous. In the case of the arc light about 10 per cent. is luminous, while in the light emitted by the firefly or the glow-worm practically all the radiation is luminous.

Radiator, Electric — — An electric heater so placed as to radiate its heat into the room or space to be heated.

Any electric heater applied to heat the air or space that surrounds it may be regarded as an electric radiator.

Electric radiators are generally so placed as to prevent direct contact with their heated surfaces.

Radiophonic Sounds.—(See Appendix—*Sounds, Radiophonic.*)

Railroad, Conductor System for — — A system for the propulsion of cars by means of electricity taken from a conductor placed near the road. (See *Railroads, Electric, Dependent System of Motive Power for.*)

Railway, Electric, Battery System for — — A system for the propulsion of cars by means of electricity derived from storage or secondary batteries placed on the cars. (See *Railroads, Electric, Independent System of Motive Power for.*)

Railway Generator.—(See Appendix—*Generator, Railway.*)

Raindrops, Electrical Aggregation of — — The coalescence of a number of separate raindrops into a single drop by the action of electricity.

Rayleigh has observed the fact that if a vertical water-jet is subjected to the influence of an electrified stick of sealing wax held a short dis-

tance from the drop, the jet at once shrinks upon itself and greatly changes its appearance, a great number of separate drops collecting into single larger drops.

Examining the drops by means of intermittent illumination the coalition of the separate drops can be readily seen. When no difference of potential exists between the separate drops they do not unite or coalesce, but when a difference of potential exists, coalescence occurs, and, since such coalescence causes an increased difference of potential, the drops rapidly increase, both in size and potential difference.

Ratio of Conversion.—(See Appendix—*Conversion, Ratio of.*)

Ratio of Transformation.—(See Appendix—*Transformation, Ratio of.*)

Rays, Anodic, of Vacuum Tube — —
The rays of light which appear in the neighborhood of the anode of a vacuum tube through which a rapid electric discharge is passing.

Rays, Kathodic, of Vacuum Tube — —
The rays of light which appear in the neighborhood of the cathode of a vacuum tube through which a rapid electric discharge is passing.

Reactance.—A term proposed by Hospitalier for a quantity of the same dimensions as the resistance, which does not absorb energy, and the square of which added to the square of the resistance gives the square of the impedance to simple harmonic currents.

Calling C_{eff} , the effective current, E_{eff} , the effective electromotive force, ω , the pulsation, or 2π times the frequency, then—

$$C_{\text{eff}} = \frac{E_{\text{eff}}}{\sqrt{R^2 + \left(\omega L - \frac{1}{\omega K}\right)^2}}.$$

The factor in the parenthesis is what Hospitalier proposes to call the reactance.

Reaction, Armature — —The reactive magnetic influence produced by the current in the armature of a dynamo or motor upon the magnetic circuit of the machine.

Red Magnetic Pole.—(See Appendix—*Pole, Magnetic, Red.*)

Redressed.—Commuted or caused to take the same direction.

The commutator redresses or commutes the currents in the armature and causes them to flow in the same direction.

Regenerative Cell.—(See Appendix—*Cell, Regenerative.*)

Region, Equatorial, of Magnet — —A term sometimes employed for the portions of a magnet which lie near the equator. (See *Magnet, Equator of.*)

Registering Declination Magnetometer.—(See Appendix—*Magnetometer, Registering Declination.*)

Regulating Socket.—(See Appendix—*Socket, Regulating.*)

Relay Contact.—(See Appendix—*Contact, Relay.*)

Relay, Kick of — —(See Appendix—*Kick of Relay.*)

Relay, Polar, Telegraphic — —A telegraphic relay provided with a polarized armature. (See *Armature, Polarized.*)

Reluctancy.—An alternative word proposed for reluctivity. (See *Reluctivity, Reluctance, Magnetic.*)

Reluctivity, Proposed A. I. E. E. Definition for — —The reciprocal of permeability.

Remanent Magnetism.—(See Appendix—*Magnetism, Remanent.*)

Repeater, Automatic — —A telegraphic repeater which acts automatically. (See *Repeaters, Telegraphic.*)

Repeater, Button — —A form of manual repeater. (See *Repeaters, Telegraphic.*)

Repeater, Electro-Magnetic, Callan's — —A term formerly applied to a variety of vibrating contact breaker.

Repeater, Manual — —A telegraphic repeater which is operated by hand. (See *Repeaters, Telegraphic.*)

Repeater, Non-Automatic — —A term sometimes employed for manual repeater. (See *Repeaters, Telegraphic.*)

Repeating Telegraphic Station.—(See Appendix—*Station, Repeating Telegraphic.*)

Repulsion Electrometer.—(See Appendix—*Electrometer, Repulsion.*)

Residue, Electric — —A term proposed for residual charge.

The term electric residue would appear to be entirely unnecessary.

Resistance, Apparent — —A term sometimes employed for the impedance of a circuit or the resistance it offers to the passage of an alternating current.

Resistance, Conduction — —The resistance offered by a conductor to the passage of an electric current.

Resistance, Conductor — —A term frequently employed for copper resistance. (See Appendix—*Resistance, Copper.*)

Resistance, Contact — —A resistance produced by the contact of two surfaces.

Resistance, Copper — —A term frequently employed for expressing the resistance of a telegraphic conductor.

The value of the copper resistance is generally expressed in ohms-per-mile, ohms-per-knot or ohms-per-kilometre.

Resistance, Electric, of Metals, Effect of Temperature on — —A change in the resistance of a metal following a given change in temperature.

At decreasing temperatures an increase occurs in the electric conducting power of the metals.

Dewar, by means of the intense cold produced by liquefied oxygen, found that at very low temperatures all pure metals increase in their conducting power as the temperature decreases. The temperature curve is such that, the resistivity of pure metals would be zero at, or even before, the absolute zero of temperature. In such a case, if a wire or conductor of pure metal were placed in the approximately absolute zero of interstellar space, electricity would pass through it without loss. This must, however, be regarded only as a hypothesis.

According to Dewar, most non-conducting bodies show a conductivity decreasing with the temperature.

Resistance of Telegraphic Leak.—(See Appendix—*Leak, Telegraphic, Resistance of.*)

Resistance, Passive — —A term sometimes employed for the ohmic resistance of a circuit. (See *Resistance, Ohmic.*)

Resistance, Specific Magnetic — —A word proposed for reluctivity. (See *Reluctivity.*)

Resistance, Transition — —A term formerly employed for the resistance experienced by a voltaic cell shortly after closing a circuit.

The transition resistance was inferred from the decrease in the current strength, and was formerly attributed to a change in the character of the electrode. It is now generally ascribed to the electromotive force of polarization.

This term is also employed in a somewhat similar sense in electro-therapeutics. (See *Resistance, Transition.*)

Resistivity.—A term proposed for specific resistance. (See *Resistance, Specific.*)

Resistivity is the inverse of specific conductivity.

Resonance, Acoustic — —The excitement or production of waves or vibrations of sound in an elastic body by means of successive impulses received by such body from the sound waves striking it.

Acoustic resonance is a particular case of sympathetic vibrations. Like all cases of such vibrations, there must exist between the sonorous body in which the waves of vibrations are excited, and the body which is producing the exciting waves, an identity of wave length; or, in other words, there must exist between the two strict synchronism, so that the effects of timed impulses may be permitted.

Resonant Circuit.—(See Appendix—*Circuit, Resonant.*)

Resultant Fault.—(See Appendix—*Fault, Resultant.*)

Resultant Magnetic Pole.—(See Appendix—*Pole, Resultant Magnetic.*)

Retarding Disc.—(See Appendix—*Disc, Retarding.*)

Reversals.—In telegraphy, alternate current signals transmitted for the purpose of

adjustment; as, for example, in obtaining a duplex balance.

Reversible Heating Effect of Electricity.—(See Appendix—*Electricity, Reversible Heating Effect of.*)

Rheostat, Adjustable — — An adjustable resistance, in a compound-wound dynamo-electric machine, employed to adjust compounding for a greater or less than tested speed or a greater or less wiring loss.

A term sometimes employed for a rheostat, or a resistance that can readily be adjusted or altered. (See *Rheostat.*)

Strictly speaking, any rheostat is an adjustable resistance; therefore, this latter use of the term adjustable rheostat would seem to be unnecessary.

Ribbon Induction Coil.—(See Appendix—*Coil, Induction Ribbon.*)

Right-Hand Trolley Switch.—(See Appendix—*Switch, Right-Hand Trolley.*)

Right-Handed Helix.—(See Appendix—*Helix, Right-Handed.*)

Right-Handed Rotation.—(See Appendix—*Rotation, Right-Handed.*)

Right-Handed Spiral.—(See Appendix—*Spiral, Right-Handed.*)

Ring, Galvanic — — A term sometimes applied to a galvanic, or, more properly speaking, voltaic circuit. (See *Circuit, Voltaic.*)

Ripple Marks.—(See Appendix—*Marks, Ripple, Electrical.*)

Rise.—In interior house wiring that portion of a conductor which rises vertically from one floor to another.

Rocking Switch. — (See Appendix—*Switch, Rocking.*)

Rosette, Ceiling — — A ceiling block of ornamental and rosiform design.

Rotary Converter.—(See Appendix—*Converter, Rotary.*)

Rotary Transformer.—(See Appendix—*Transformer, Rotary.*)

Rotation, Electro-Dynamic — — “The rotation of a magnetic field produced as the resultant of two or more magnetic or magnetizing forces of variable intensity acting at an angle to one another, whose maxima do not coincide, but whose periods are the same.” —*Gutmann.*

Rotation, Left-Handed — — A rotation the direction of which is opposite to that of the hands of a watch when one looks directly at the face of the watch.

Rotation, Right-Handed — — A rotation the direction of which is the same as that of the hands of a watch when one looks directly at the face of the watch.

A direction the same as that of an ordinary right-handed screw, when we turn the upper side of the right-hand outwards.

Rubber Tape.—(See Appendix—*Tape, Rubber.*)

Rumble.—A barrel or other hollow box revolved by mechanical power in which small articles that are to be electro-plated are placed for the purpose of polishing them.

When subjected to the rotation of the barrel the articles became polished by friction against one another. Some dry sawdust is frequently placed in the barrel, to aid in the polishing process.

Running Torque of Motor.—(See Appendix—*Torque, Running, of Motor.*)

S

S.— A symbol proposed for surface.

The defining equation is $S = L \times L$.

s.—An abbreviation proposed for second, the C. G. S. unit of time.

S. N. Telegraphic Instrument.—(See Appendix—*Instrument, S. N., Telegraphic.*)

S. P. Cut-Out.—(See Appendix—*Cut-Out, S. P.*)

Sag of Conductor or Line Wire.—(See Appendix—*Conductor or Line Wire, Dip of.*)

Scalar Potential.—(See Appendix—*Potential, Scalar.*)

Secondary Spiral of Induction Coil.—(See Appendix—*Spiral, Secondary, of Induction Coil.*)

Section Box.—(See Appendix—*Box, Section.*)

Segment, Dark, of Aurora — —A dark or non-illuminated portion of the sky in the neighborhood of an aurora.

Segment, Unlighted, of Aurora — — A term employed by Nordenskjöld in place of dark segment of aurora. (See Appendix—*Segment, Dark, of Aurora.*)

Selective Emission.—(See Appendix—*Emission, Selective.*)

Selective Radiation.—(See Appendix—*Radiation, Selective.*)

Selective Signal.—(See Appendix—*Signal, Selective.*)

Selective Signalling Apparatus.—(See Appendix—*Apparatus, Selective Signalling.*)

Self-Compounding Polyphase Generator.—(See Appendix—*Generator, Self-Compounding Polyphase.*)

Self-Induction Coil.—(See Appendix—*Coil, Induction, Self.*)

Self-Starting Synchronous Motor.—(See Appendix—*Motor, Synchronous, Self-Starting.*)

Semaphoric Electroscop.—(See Appendix—*Electroscope, Semaphoric.*)

Semi-Circular Deviation of Mariner's Compass.—(See Appendix—*Deviation, Semi-Circular, of Mariner's Compass.*)

Semi-Conductors.—(See Appendix—*Conductor, Semi.*)

Sensitiveness of Telephone.—(See Appendix—*Telephone, Sensitiveness of.*)

Separable Conducting Cord Tip.—(See Appendix—*Tip, Conducting Cord, Separable.*)

Separate-Coil Alternator.—(See Appendix—*Alternator, Separate-Coil.*)

Separate-Coil Alternating Dynamo-Electric Machine.—(See Appendix—*Ma-*

chine, Dynamo-Electric, Separate-Coil Alternating.)

Separately-Excited Alternating Dynamo-Electric Machine.—(See Appendix—*Machine, Dynamo-Electric, Separately Excited Alternating.*)

Separately-Excited Alternator.—(See Appendix—*Alternator, Separately-Excited.*)

Separator, Electro-Magnetic — —A device for separating the useful ore from the dross in low grade finely granulated iron ores.

Septum.—A wall or diaphragm through which osmotic diffusion can take place. (See *Osmose. Osmose, Electric.*)

Series, Branched — —A term sometimes employed in place of series-multiple. (See *Series-Multiple.*)

Series Connection of Alternators.—(See Appendix—*Alternators, Series Connection of.*)

Series, Potential, Dynamos Coupled in — —A term sometimes employed in telegraphy for a particular coupling of dynamo-electric machines in series.

In the application of a number of dynamo-electric machines to the operation of telegraphic lines in a central station, where a number of different lines enter or leave the station, different voltages are required on the different lines. These different voltages are most readily obtained by coupling the machines in what is called potential series.

In potential-series coupling, the dynamos are connected together in series, that is, the positive brush of one dynamo is connected to the negative brush of another, its positive brush to the negative of another, and so on throughout the series. One terminal of the battery of dynamos is grounded, and the other connected to the line. The terminals of the various telegraphic lines are then connected to points of junction of contiguous dynamos where their opposite brushes are connected. By these means the requisite difference of potential is readily obtained.

Series Working of Alternating Dynamo-Electric Machines.—(See Appendix—*Machines, Dynamo-Electric, Alternating, Series Working.*)

Service Block.—(See Appendix—*Block, Service.*)

Shackle Insulator.—(See Appendix—*Insulator, Shackle.*)

Shading, Magnetic — —A term sometimes employed for magnetic screening. (See *Screening, Magnetic.*)

Sheath, Closed-Conducting, for Lightning Protection — —A form of lightning conductor proposed by Maxwell, consisting essentially of a net-work or cage-like conductor surrounding the house or building to be protected.

The theory for the protection of a building by means of a conducting sheath is based on the well known fact that there is no trace of electrostatic charge inside a hollow conductor.

It is now well known that there are circumstances under which the closed-conducting circuit does not thoroughly protect a building on which it is placed. If the number of such circuits is sufficiently great so as to form a close-meshed cage, the protection thus afforded is excellent. Such a sheath, however, might be dangerous to touch.

Lodge, who has studied the matter of lightning protection very thoroughly, thus humorously remarks concerning the system of sheath lightning protection:

“It would be unpleasant, when you are driven home out of a storm, to find it so highly charged as to knock you down directly you tried to enter. An earth connection is necessary as well.”

Shell, Complex-Magnetic — —A magnetic shell whose strength varies from one part to another.

A complex magnetic shell will result from the overlapping of a number of simple magnetic shells.

Shell, Copper, of Electrotype — —A thin sheet of electrolytically deposited copper.

The copper shell is rendered sufficiently rigid for use by being covered with a backing of type metal.

In order to permit this metal readily to adhere to the back of the shell it is thoroughly cleansed and then covered on the back with sheets of tin-foil, which are melted in the backing-pan preparatory to receiving the coating of type metal.

Shell, Simple Magnetic — —A magnetic shell whose strength is everywhere equal.

Shifting of Spot of Light.—A movement of a spot of light on a scale produced by other causes than those acting during the proper operation of the instrument, and causing the spot of light to move away from its true zero position.

In the case of a galvanometer the spot of light, instead of remaining at the zero point, shifts or moves from one side to another of the zero point.

This movement is sometimes called the drifting of the zero point.

The shifting of the spot of light is, of course, caused by the drift of the needle.

Shunting Air Gap.—(See Appendix—*Gap, Air, Shunting.*)

Shunt-Out.—A cut-out device for removing an electro-receptive device from a circuit, without breaking the circuit, by providing a short circuit between its terminals.

An electro-magnetic cut-out provides a shunt-out of the device it is desired to cut-out. It will be seen, however, that all a shunt-out does is to provide a by-path, the resistance of which is so small as compared with the resistance of the device cut-out, that practically all the current flows past the device through the shunt path, thus practically cutting it out from the circuit; or, more properly speaking, cutting it out from the operative current.

Side Arms. — (See Appendix — *Arms, Side.*)

Signal, Individual — —In any system of electric communication devices by means of which bells or other signals, at two or more stations electrically connected in the same circuit, are not operated at all of the stations by the calls sent over the line to the call bell at any particular station, but in which each particular bell is only operated by its own call to the exclusion of the other calls.

Signal, Selective — —A term sometimes employed in place of individual signal. —(See Appendix—*Signal, Individual.*)

Signal, Telegraphic, Audible — —Telegraphic signals that can be heard.

Examples of audible telegraphic signals are to be found in the signals given by various sounders of the Morse type.

The signals of electric bells are also audible signals.

Signal, Telegraphic, Evanescent — — Telegraphic signals that leave no permanent record.

Examples of evanescent telegraphic signals are found in the audible signals produced by most forms of telegraphic sounders.

Signal, Telegraphic, Permanent — — Telegraphic signals that are recorded by any means which leaves a permanent record.

The various forms of recording or registering apparatus employed in telegraphy produce permanent signals.—(See *Recorder, Morse. Recorder, Chemical, Bain's. Recorder, Siphon. Register, Telegraphic.*)

Signal, Telegraphic, Visual — — Telegraphic signals that can be seen.

Examples of visual telegraphic signals are to be found in the various galvanometric receiving apparatus employed in cable telegraphy, or, in general, in needle telegraphy. The signals received on the siphon recorder, for example, are visible signals. (See *Recorder, Siphon.*)

Simple Alternating or Two-Phase Current.—(See Appendix—*Current, Simple or Two-Phase Alternating.*)

Simple-Magnetic Shell.—(See Appendix—*Shell, Simple-Magnetic.*)

Single-Current Telegraphic Working.—(See Appendix—*Working, Single-Current, Telegraphic.*)

Single Curve Pull-Off.—(See Appendix—*Pull-Off, Single Curve.*)

Single-Liquid Voltaic Cell.—(See *Cell, Voltaic, Single-Fluid.*)

Single-Phase Motor.—(See Appendix—*Motor, Single-Phase.*)

Single-Pole Cut-Out.—(See Appendix—*Cut-Out, Single-Pole.*)

Single-Wire System for Electric Light Leads.—(See Appendix—*Leads, Single-Wire System for Electric Light.*)

Sinusoidal Current.—(See Appendix—*Current, Sinusoidal.*)

Six-Pole Dynamo-Electric Machine.—(See Appendix—*Machine, Dynamo-Electric, Six-Pole.*)

Six-Wire System.—(See Appendix—*System, Six-Wire.*)

Skew Adjustment of Carbons in Arc Lamp.—(See Appendix—*Carbons, Skew Adjustment of, in Arc Lamp.*)

Skin Currents.—(See Appendix—*Currents, Skin.*)

Sliding Joint.—(See Appendix—*Joint, Sliding.*)

Slinging Wires.—(See Appendix—*Wires, Slinging.*)

Slipping of Belt.—(See Appendix—*Belt, Slipping of.*)

Smashing Point of Incandescent Electric Lamps.—(See Appendix—*Point, Smashing, of Incandescent Electric Lamps.*)

Snapper Sounder.—(See Appendix—*Sounder, Snapper.*)

Socket Base.—(See Appendix—*Base, Socket.*)

Socket, Pendant — —An attachment to a socket provided with a chain or chains for turning on or off a lamp not readily accessible.

Socket, Regulating — —A lamp socket fitted with an adjustment under control of a key or switch for regulating the degree of incandescence of the filament.

Socket, Temporary — —A simple and unfinished form of socket for holding a lamp temporarily.

Solenoid, Anomalous — —A term sometimes applied to a solenoid with consequent poles. (See *Solenoid, Practical.*)

Solution, Amalgamating — —A solution of mercury employed for readily amalgamating the zincs of a voltaic battery.

Maycock gives the following as a good amalgamating solution:

Two pounds mercury.

Five pounds nitric acid.

Ten pounds hydrochloric acid.

The mercury and nitric acid are mixed together,

and, after the mercury is dissolved, the 10 pounds of hydrochloric acid are added.

To use this liquid the zincs are first cleansed and then dipped into the solution and afterwards rinsed with clean water.

Sonometer.—A monochord. (See Appendix—*Monochord*.)

Sonometer Interrupter.—(See Appendix—*Interrupter, Sonometer*.)

Sorter, Electro-Magnetic — —An electro-magnetic separator, sometimes applied to a magnetic separator. (See Appendix—*Separator, Electro-Magnetic*.)

Sounder Push.—(See Appendix—*Push, Sounder*.)

Sounder, Snapper — —A sounder for producing the sounds corresponding to the Morse characters, as they are heard on a sounder, in which the audible signals are produced by the flexure of a spring.

A sounder snapper consists essentially of a dented spring plate firmly connected at one end and the other end moved to-and-fro by hand.

It is used to produce sounds similar to those of the regular electro-magnetic sounder, only, instead of being operated by an electric current, it is operated solely by hand.

Sounder, Telegraphic Box — —A sounder, the receiving magnets of which are enclosed in a hollow box for the purpose of increasing the intensity of the sound by means of resonance.

Sounds, Radiophonic — —Sounds resulting from the direct action of radiation on certain bodies. (See *Sonorescence*.)

It is the photophonic sounds, produced in the receiving instrument of a photophone, that are employed for the transmission of speech or other intelligence. (See *Photophone*.)

Mercadier gives the following conclusions as the result of his experiments on radiophonic sounds:

(1.) "The radiophone (radiophonic sound) does not appear to be an effect produced by the mass of the receiving plate vibrating transversely, like an ordinary vibrating plate. The nature of the molecules of the receiver and their mode of aggregation do not appear to exercise a predominant influence on the production of sounds.

"The radiophonic phenomena appear to result principally from an action exercised at the surface of the receiver, and are amplified when this surface is covered with substances like lamp-black, platinum-black, and the like.

(2.) "Radiophonic sounds result from the direct action of radiations on the receivers. Radiophonic sounds are produced principally by the undulations of great length of wave, called 'calorific.'

(3.) "The medium in which radiophonic vibration is produced is the layer of condensed air on the surface of the receivers. This layer of air, particularly when the surfaces are smoked, or covered with a substance absorbing heat, is alternately heated and cooled by intermittent radiations, with the result that periodic and regular dilatations and contractions are set up; hence a vibratory movement communicated to the adjacent gaseous layers, which also vibrate directly under the same influence.

(4.) "Radiophonic sounds cannot be produced unless the medium which surrounds the receiving surfaces is gaseous. A liquid or solid medium cannot produce them; but a gaseous medium containing vapor, particularly vapor of ammonia or ether, develops them in a remarkable way: those vapors which have the greatest absorbing thermic power give out the greatest effects."

Source, Magnetic — —Any arrangement of parts capable of producing lines of magnetic force.

A permanent magnet, an electro-magnet, or a circuit through which an electric current is passing, may act as a magnetic source.

Spark Chronograph.—(See Appendix—*Chronograph, Spark*.)

Spark Discharge.—(See Appendix—*Discharge, Spark*.)

Spark, Electric — —The phenomena produced by a disruptive discharge in the air space or gap through which the discharge passes.

Spark, Negative — —A spark produced by the discharge of a negatively charged conductor.

Spark, Positive — —A spark produced by the disruptive discharge of a positively charged conductor.

Sparking Terminals.—(See Appendix—*Terminals, Sparking.*)

Speaking Telegraph.—(See Appendix—*Telegraph, Speaking.*)

Speaking-Tube Annunciator.—(See Appendix—*Annunciator, Speaking-Tube.*)

Specific Conductance.—(See Appendix—*Conductance, Specific.*)

Specific Dielectric Capacity.—(See Appendix—*Capacity, Specific Dielectric.*)

Specific Energy.—(See Appendix—*Energy, Specific.*)

Specific Inductance.—(See Appendix—*Inductance, Specific.*)

Specific Magnetic Resistance.—(See Appendix—*Resistance, Specific Magnetic.*)

Specific Magnetism.—(See Appendix—*Magnetism, Specific.*)

Spectro-Photometer.—(See Appendix—*Photometer, Spectro.*)

Spectrum, Magnetic — —A term sometimes employed in place of magnetic figure or magnetic field.

The term magnetic spectrum is unfortunate since magnetic figures so produced can hardly be regarded as spectra, but merely as collections of iron filings arranged in the order which the lines of magnetic force take in the space or atmosphere outside the magnet.

Speed, Inductance — —A term proposed for the product of a coefficient of self-induction by an angular velocity.

Speeding of Machine.—(See Appendix—*Machine, Speeding of.*)

Spiral.—A term sometimes employed in electricity and magnetism in place of an open coil. (See *Coil, Electric.*)

Spiral, Anomalous — —A term sometimes employed in place of an anomalous helix or solenoid. (See Appendix—*Solenoid, Anomalous.*)

Spiral, Left-Handed — —A term sometimes employed in place of left-handed solenoid. (See *Solenoid, Left-Handed. Solenoid, Practical.*)

Spiral, Magnetic — —A term some-

times employed in place of magnetic helix. (See *Coil, Electric.*)

Spiral, Magnetizing — —A term sometimes employed in place of a magnetizing helix or coil. (See *Coil, Electric.*)

Spiral, Primary, of Induction Coil — —A term sometimes employed for the primary of an induction coil. (See *Coil, Induction.*)

Spiral, Right-Handed — —A term sometimes employed in place of right-handed solenoid. (See *Solenoid, Right-Handed. Solenoid, Practical.*)

Spiral, Secondary, of Induction Coil — —A term sometimes employed for the secondary of an induction coil. (See *Coil, Induction.*)

Spontaneous Electricity.—(See Appendix—*Electricity, Spontaneous.*)

Spools, Field, of Dynamo-Electric Machine — —A term sometimes employed for the forms on which the field coils are wound.

Spring Relay Contact.—(See Appendix—*Contact, Spring Relay.*)

Spring Voltmeter. — (See Appendix—*Voltmeter, Spring.*)

Standard Clock.—(See Appendix—*Clock, Standard.*)

Standard Trolley Switch.—(See Appendix—*Switch, Standard Trolley.*)

Standards.—Telegraphic or telephonic supports placed on the roof of a building for the purpose of supporting telegraphic or telephonic wires or conductors.

Standards, Dynamo — —A term applied to the supports for the bearings of a dynamo.

Starting Box of Shunt-Wound Motor.—(See Appendix—*Box, Starting, of Shunt-Wound Motor.*)

Starting Current of Motor.—(See Appendix—*Current, Starting, of Motor.*)

Starting Torque of Motor.—(See Appendix—*Torque, Starting, of Motor.*)

Static Transformer.—See Appendix—*Transformer, Static.*)

Station, Repeating Telegraphic — —

A station situated at some intermediate point on a long telegraphic line where the currents from the sending station are passed through a relay by means of which they are sent on to the next station by means of a current from a local battery.

Station, Translating Telegraphic — —

—A receiving station.

The station at which the signals are received.

Stay-Eye Clips.—(See Appendix—*Clips, Stay-Eye.*)

Steeling, Electro — —The art of covering copper electros with hardened iron.

Steel-Yard Ammeter.—(See Appendix—*Ammeter, Steel-Yard.*)

Steeps.—A word sometimes employed in electro-plating for dips or dipping liquids or solutions.

Steno-Telegraphy. — (See Appendix—*Telegraphy, Steno.*)

Stereotype, Electro — —A word sometimes employed for electrotype.

The term electrotype would appear to be preferable.

Sticking of Magnetic Armature.—(See Appendix—*Armature, Magnetic Sticking of.*)

Stimulation, Unipolar, of a Nerve — —

—The stimulation of a nerve produced by the application of a single electrode to the nerve.

This term was proposed by Du Bois Reymond, and is sometimes employed in electro-therapeutics. According to Reymond unipolar stimulation of a nerve is due to the action of the to-and-fro motions of the electric current between the free ends of the open induction circuit at the moment of induction.

Stimulus, Electrical, of Nerve — —

The effect which electricity produces by its passage through a nerve.

Landois and Sterling give the following facts concerning the electric stimulation of a nerve :

The stimulation is more powerful—

(1.) At the moment the current is completed.

(2.) At the moment the current ceases.

(3.) When a constant electric current increases or decreases in its strength. The more rapid the variations, the more energetic the stimulation.

(4.) To stimulate a nerve, the current must have a certain duration.

(5.) The electric current is most active when applied to the longer axis of the nerve, and becomes inactive when applied at right angles to this axis.

(6.) The greater the length of nerve treated by the current, the smaller is the stimulus that is required.

Stone, Bolognian — —A term originally applied to a calcareous substance that became phosphorescent on exposure to light.

Stoneware Dipping Basket.—(See Appendix—*Basket, Stoneware Dipping.*)

Stoneware Dipping Bowl.—(See Appendix—*Bowl, Stoneware Dipping.*)

Stopping-Off Process.—(See Appendix—*Process, Stopping-Off.*)

Stopping-Out Process.—(See Appendix—*Process, Stopping-Out.*)

Storage Accumulator.—(See Appendix—*Accumulator, Storage.*)

Storage Battery, Formed Plates of — —
—(See Appendix—*Plates, Formed, of Storage Cell.*)

Stove, Plate, Electric — —A form of electric stove in which the heat is imparted to the plate from a suitably shaped resistance.

A form of plate stove is shown in Fig. 580, a.

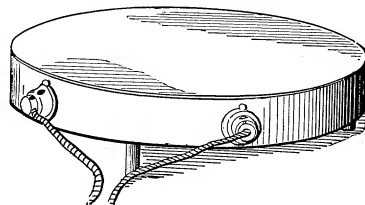

Fig. 580. Electric Plate Stove.

part of the top being cut away to show the electric heater.

Strain.—The deformation produced by the action of a stress.

Strain, Electrostatic — —A strain or deformation produced in any medium by

means of the stress caused by an electrostatic field.

Stranding of Conductor.—(See Appendix—*Conductor, Stranding of.*)

Strap Key.—(See Appendix—*Key, Strap.*)

Streams, Phantom — —A term sometimes applied to a variety of the Tesla streaming discharge. (See *Discharge, Streaming.*)

Striking Distance.—(See Appendix—*Distance, Striking.*)

Striking Distance for Various Substances.—(See Appendix—*Distance, Striking, for Various Substances.*)

Striking Mechanism of Arc Lamp.—(See Appendix—*Lamp, Arc, Striking Mechanism of.*)

Stroboscope.—An instrument employed in the study of periodic motion.

The stroboscope is based on the illumination at frequent intervals of the body whose motion is to be studied.

Stroboscopic.—Of or pertaining to the stroboscope.

Struck.—A word employed in electroplating to characterize a surface that has been covered with a film of electro-deposited nickel by being placed in a bath and exposed for a few moments to the action of a strong current.

When the surface of the article to be plated has been struck or covered with a thin film of nickel, the remainder of the coating is deposited on the surface by the action of a weaker current.

Successive Contact Key.—(See Appendix—*Key, Successive Contact.*)

Surgings Circuit.—(See Appendix—*Circuit, Surgings.*)

Surgings, Induced Electric — —Electrical surgings induced in neighboring conductors by means of electrical surgings or oscillating discharges. (See *Discharge, Oscillating.*)

Suspension of Compass Needle, Cardan's — —A term sometimes employed for gimbal suspension. (See *Gimbals.*)

Sweeping-Out Charge.—(See Appendix—*Charge, Sweeping-Out.*)

Swinging Annunciator.—(See Appendix—*Annunciator, Swinging.*)

Switch, Automatic Photo-Electric — —A switch that is automatically opened or closed on the exposure of its face to differences of illumination.

A selenium cell is so placed in a circuit in combination with an electro-magnetic switch that when one of the selenium faces is exposed to the decreasing illumination of approaching night a current is produced by such decrease of light, the direction of which is such as to automatically turn on or light an electric lamp, and conversely, on the approach of daylight and the consequent increase of solar illumination, to turn off the light.

Switch, D. B. — —A contraction for double-break switch. (See *Switch, Double-Break.*)

Switch, D. P. — —A contraction for double-pole switch. (See *Switch, Double-Pole.*)

Switch, Flush Key — —A switch whose mechanism is contained in a box, the face of which is flush with the wall or other support to which the switch is attached.

The switch is opened or closed by means of a key.

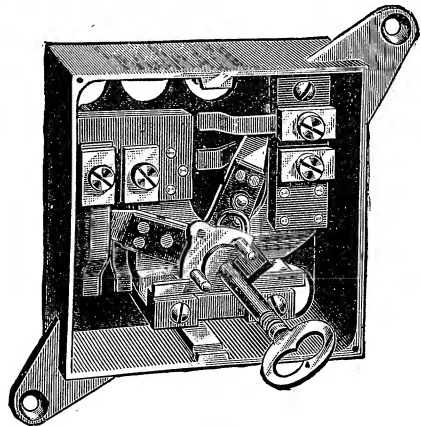

Fig. 581. Flush Key Switch.

A form of flush switch is shown in Fig. 581 in which a removable key, instead of the ordinary, fixed key, is employed for opening and closing the switch.

Switch, Four-Way — —A term sometimes employed in place of four-point switch. (See *Switch, Four-Point.*)

Switch, Jack — —A term sometimes employed in place of spring-jack. (See *Spring-Jack.*)

Switch, Left-Hand Trolley — —In a system of electric street railways a trolley switch designed for use at a point where a branch trolley leaves the main line to the left-hand side in the going direction.

Switch, Lever — —Any form of switch in which the circuit is closed or opened by means of the movement of a lever arm.

Switch, Push — —A switch included in a push case and operated by means of a push button.

In push switches successive motions of the button make or break the circuit.

Switch, Quick-Break — —A switch by means of which a circuit is rapidly or quickly broken.

Switch, Right-Hand Trolley — —In a system of electric street railways a switch designed for use at a point where a branch trolley wire leaves the main line to the right in the going direction.

Switch, Rocking — —A form of switch operated by means of an electro-magnet by which storage cells are automatically removed from the circuit of the charging dynamo to prevent the battery from discharging through it in case the voltage of the dynamo falls below the E. M. F. of the battery.

Switch, Standard Trolley — —In a system of electric railways the device employed to hold together the trolley wires at any point where the wire branches, and for automatically guiding a trolley wheel along the wire over the track taken by the car.

Switch, T. P. — —A contraction for Triple-Pole Switch. (See Appendix—*Switch, Triple-Pole.*)

Switch, Three-Way — —A term sometimes employed in place of three-point switch. (See *Switch, Three-Point.*)

Switch, Three-Way Trolley — —In a system of electric street railways, a trolley switch designed for use at a point where the line branches in three directions.

Switch, Triple-Pole — —A switch consisting of a combination of three separate switches for opening or closing the three circuits at the same instant.

Symmetrical Electrometer.—(See Appendix—*Electrometer, Symmetrical.*)

Symphonance.—A word proposed in place of resonance. (See *Resonance, Electric.*) (See Appendix—*Resonance, Acoustic.*)

Synchronous-Multiplex Telegraph.—(See Appendix—*Telegraph, Synchronous-Multiplex.*)

Synthesis, Electro — —The combination of electro-positive and electro-negative radicals under the influence of electricity.

Syringe, Battery — —A syringe arranged to readily transfer the acid or spent liquids from a voltaic cell or battery for the introduction of fresh liquid.

System, Delta Tri-Phase — —A tri-phase system in which the terminal connections resemble in form the Greek letter delta.

System, Electrically Tuned — —A term sometimes employed for a circuit or system of circuits that has been brought into electrical resonance with another circuit or system of circuits. (See *Resonance, Electric.*)

System, Five-Wire — —A system similar in its arrangements to the three-wire system in which four dynamos are connected to five wires or conductors. (See *System, Three-Wire.*)

In such a case there are three wires or conductors occupying the position corresponding in general to the neutral wire or conductor in a three-wire system.

System, Four-Wire — —A system similar in its general arrangement to the three-wire system, in which three dynamos are connected to four wires or conductors. (See *System, Three-Wire.*)

In such a case there are two wires or conductors occupying in general a position correspond-

ing to the neutral wire of the three-wire system. (See *System, Three-Wire.*)

System, Municipal, of Electric Lighting — —A series system of incandescent lighting invented by Edison for use in cities, particularly for street or window lamps, and operated at a total continuous current pressure of 1,000 volts.

System, Six-Wire — —A system similar in general to the three-wire system in which five dynamos are connected to six conductors or leads. (See Appendix—*System, Five-Wire.*)

System, Y Tri-Phase — —A tri-phase system in which the terminal apparatus resembles in form the capital letter Y.

T

t.—A symbol used for time.

t : m.—An abbreviation proposed for revolutions per minute, a practical unit of angular velocity.

T. P. Switch.—(See Appendix—*Switch, T. P.*)

Tap Wire in Quadruplex Telegraphy.—(See Appendix—*Wire, Tap, in Quadruplex Telegraphy.*)

Tape, Kerite — —A kerite covered insulating tape.

Tape, Rubber — —Insulating tape made of rubber.

Tapper Key.—(See Appendix—*Key, Tapper.*)

Tapper, Magneto — —A term sometimes employed in place of magneto key. (See *Key, Magneto-Electric.*)

Tapper, Morse — —A form of telegraphic key provided with two contacts, one in front and the other in the back, arranged so that the depression of the key makes one contact and breaks the other.

Teeth, Pacinotti — —A term sometimes employed in place of Pacinotti projections. (See *Projections, Pacinotti.*)

Telegram.—A telegraphic dispatch or communication.

Literally, anything written by means of a telegraph.

Telegraph.—Any instrument or combination of instruments for conveying a communication or dispatch to a distance by means other than the unassisted voice.

Telegraph, Acoustic — —A general term embracing the apparatus employed in acoustic telegraphy. (See *Telegraphy, Acoustic.*)

Telegraph, Automatic — —A general term embracing the apparatus employed in automatic or machine telegraphy. (See *Telegraphy, Automatic.*)

Telegraph, Chemical — —A general term embracing the apparatus employed in chemical telegraphy. (See *Telegraphy Chemical.*)

Telegraph, Contraplex — —A general term embracing the apparatus employed in contraplex telegraphy. (See *Telegraphy, Contraplex.*)

Telegraph, Dial — —A general term embracing the apparatus employed in dial telegraphy. (See *Telegraphy, Dial.*)

Telegraph, Diplex — —A general term embracing the apparatus employed in diplex telegraphy. (See *Telegraphy, Diplex.*)

Telegraph, Duplex — —A general term embracing the apparatus employed in duplex telegraphy. (See *Telegraphy, Duplex, Bridge Method of. Telegraphy, Duplex, Differential Method of.*)

Telegraph, Electric — —An electrical instrument for conveying a communication or dispatch to a distance by means other than the unassisted voice.

Electric telegraphs are of a great variety of forms. They may be divided into classes, either according to the number of dispatches they can simultaneously transmit, or according to the

method employed for transmitting or receiving the dispatches.

According to the number of messages they can transmit simultaneously, telegraphs are divided into duplex, diplex, contraplex, quadruplex, multiplex, phonoplex, harmonic, synchronous-multiplex, etc., etc.

According to the differences in the method of transmitting and receiving the messages, they are divided into the electro-magnetic, the needle, the chemical, the dial, the fac-simile, the writing, the acoustic, the speaking, the induction, the automatic, the fire-alarm, etc., etc.

Telegraph, Electro-Magnetic — —A general term embracing the apparatus employed in the various systems of electro-magnetic telegraphy.

Telegraph, Fac-Simile — —A general term embracing the apparatus employed in fac-simile telegraphy. (See *Telegraphy, Fac-Simile*.)

Telegraph, Fire-Alarm — —A general term embracing the apparatus employed in fire-alarm telegraphy. (See *Telegraphy, Fire-Alarm*.)

Telegraph, Harmonic — —A general term embracing the apparatus employed in harmonic telegraphy. (See *Telegraphy, Gray's Harmonic Multiple*.)

Telegraph, Induction — —A general term embracing the apparatus employed in induction telegraphy. (See *Telegraphy, Induction*.)

Telegraph, Multiplex — —A general term embracing the apparatus employed in multiplex telegraphy. (See *Telegraphy, Multiple*.)

Telegraph, Needle — —A general term embracing the apparatus employed in needle telegraphy. (See *Telegraphy, Needle System of*.)

Telegraph, Phonoplex — —A general term embracing the apparatus employed in phonoplex telegraphy. (See *Telegraphy, Phonoplex*.)

Telegraph, Quadruplex — —A general term embracing the apparatus employed in quadruplex telegraphy. (See *Telegraphy,*

Quadruplex, Bridge Method of. Telegraphy, Quadruplex, Differential Method of.)

Telegraph, Speaking — —A general term embracing the apparatus employed in speaking telegraphy. (See *Telegraphy, Speaking. Telephone*.)

Telegraph, Synchronous-Multiplex — —A general term embracing the apparatus employed in synchronous-multiplex telegraphy. (See *Telegraphy, Synchronous-Multiplex*.)

Telegraph, To — —To write or communicate at a distance by means of the telegraph.

Telegraph, Writing — —A general term embracing the apparatus employed in writing telegraphy. (See *Telegraphy, Writing*.)

Telegraphic Box Sounder.—(See Appendix—*Sounder, Telegraphic Box*.)

Telegraphic Interrupter.—(See Appendix—*Interrupter, Telegraphic*.)

Telegraphic Interruption.—(See Appendix—*Interruption, Telegraphic*.)

Telegraphic Polar Relay.—(See Appendix—*Relay, Polar, Telegraphic*.)

Telegraphic Spark Coil.—(See Appendix—*Coil, Spark, Telegraphic*.)

Telegraphist.—One skilled in the art of transmitting intelligence by means of the telegraph.

Telegraphy, Air — —A term sometimes employed for induction telegraphy. (See *Telegraphy, Induction*.)

The term air telegraphy has been applied on account of the fact that the electric impulses on one line wire or conductor are transmitted across an air space to a neighboring line wire or conductor, *i. e.*, the air acts as the dielectric through which the induction takes place.

Telegraphy, Steno — —A system of telegraphy in which the sounds of a word are represented by characters in place of letters.

Steno-telegraphy differs from ordinary telegraphy in the same manner that shorthand writing differs from longhand writing.

The object of steno-telegraphy is, of course, to insure increased economy in speed.

Tele-Indicator.—(See Appendix—*Indicator, Tele.*)

Tele-Meteorograph.—A form of meteorograph. (See Appendix—*Meteorograph.*)

Telephone Indicator.—(See Appendix—*Indicator, Telephone.*)

Telephone, Pan — —A word proposed for a certain sensitive form of telephone.

The particular form of telephone for which the name pan-telephone was proposed was an instrument with a microphone transmitter.

Telephone, Sensitiveness of — —The ability of a telephone properly to respond to currents much smaller than those required for the operation of some other telephonic apparatus.

The telephone is characterized by its extreme sensitiveness, requiring, as it does, for its operation a very small current. It is for this reason that the current produced in the telephone circuit by the induction of neighboring conductors causes the annoying cross-talk in the telephone.

Telephone, Thermo — —A telephone transmitter consisting of a tense wire, one end of which is connected with the transmitting diaphragm, placed in circuit with a receiving telephone battery, and having a current passing through it of sufficient strength to heat it.

On speaking near the wire the waves in the air periodically cool the wire, and its resistance varies, and accordingly the current in the line varies. A thermo receiver is made in a similar manner, and the telephone current heats the wire periodically and sets the diaphragm in motion.

Telephone Time Check.—(See Appendix—*Check, Telephone Time.*)

Telephonic Meter.—(See Appendix—*Meter, Telephonic.*)

Telephonist.—One skilled in the art of telephony.

Telephony.—The art of transmitting intelligence by the use of the telephone. (See *Telephone.*)

Telephony, Duplex — —A system of telephony by means of which a single line

wire or conductor can be simultaneously used by two subscribers.

Telephony, Multiplex — —A system of telephony by means of which a single line wire or conductor can be simultaneously used by a number of subscribers.

Tele-radiophone.—A form of radiophone arranged for the simultaneous transmission of telegraphic and telephonic messages.

Tele-radiophone, Auto-reversible or Multiple — —A photophone so arranged that a number of telegraphic communications may be simultaneously sent over a line wire or conductor either all in one direction or part in one direction and the remainder in opposite directions.

The adjectives auto-reversible and multiple refer to the fact that the messages can be transmitted either all in the same direction, or a number in one direction and the remainder in the opposite direction.

A multiple auto-reversible tele-radiophone is an invention of Mercadier's, based on the electrical properties of selenium.

A number of selenium cells of variable resistance are employed at the sending station, where they are placed in the circuit of a battery of a few elements and of a line wire extending to the receiving station, which is connected with a number of receivers equal to the number of selenium cells of variable resistance.

When luminous radiations are intermitted so as to have the relative succession and duration of the characters of the Morse alphabet, and these impulses are sent over the line, they affect the receivers at the other end. Each transmitter sends into the line impulses of a definite rate and only affects that receiving instrument at the other end which is tuned in unison with it. The apparatus is similar in its general action to Gray's system of multiple harmonic telegraphy. (See *Telegraphy, Gray's Harmonic Multiple.*)

Telpher Locomotive.—(See Appendix—*Locomotive, Telpher.*)

Temporary Socket.—(See Appendix—*Socket, Temporary.*)

Tension, Difference of — —An objectionable term sometimes employed in place of difference of potential.

This use of the term should be strictly avoided, as it is unnecessary and to a great extent meaningless.

Terella.—Literally, a little earth.

A sphere of hardened steel, or, as used by Gilbert, of loadstone, having marked thereon the poles and equator, and so magnetized that the distribution of its magnetism shall resemble the distribution of the earth's magnetism.

Terminals, Sparking — —Terminals between which a series of disruptive discharges are passed.

Sparking terminals are generally provided with rounded or blunt or disc-shaped ends so as to prevent a convective discharge from taking place.

Terrestrial Magnetic Induction.—(See Appendix—*Induction, Magnetic, Terrestrial.*)

Tesla Discharge.—(See Appendix—*Discharge, Tesla.*)

Tesla Frequencies.—(See Appendix—*Frequencies, Tesla.*)

Test, Blavier's — —A test introduced by Blavier for localizing a single fault in a single telegraphic line or conductor by measuring the resistance at one end of the line when the other end is alternately freed and earthed.

Test Board.—(See Appendix—*Board, Test.*)

Test, Loop — —A localization test for a single fault in a loop of two telegraphic wires, or in a complete metallic circuit.

Test, Overlap — —A localization test for a single fault in a single telegraphic line by observing the resistance from each end and deducing from the amount to which the sum of the resistances overlap the total conductor resistance of the line.

Tetrad Atom.—(See Appendix—*Atom, Tetrad.*)

Theoretical Magnet.—(See Appendix—*Magnet, Theoretical.*)

Theory, Contact, of Electricity — —A theory that ascribes the production of electricity in a voltaic cell, and to some extent

the production of electricity by friction, to the contact of dissimilar substances or surfaces.

The act of contact is assumed to produce a difference of potential. While mere contact may unquestionably produce a difference of potential, it requires the liberation of the chemical potential energy of the metal of the positive plate of a voltaic couple to maintain such differences of potential as to produce a continuous flow of a current.

Thermancy, Electro — —A term proposed for that branch of electricity which treats of the effects produced by an electric current on the temperature of a thermo-electric junction.

Thermo-Chemical Cell.—(See Appendix—*Cell, Thermo-Chemical.*)

Thermo Chemistry.—(See Appendix—*Chemistry, Thermo.*)

Thermo-Electric Generator.—(See Appendix—*Generator, Thermo-Electric.*)

Thermo-Electric Pair.—(See Appendix—*Pair, Thermo-Electric.*)

Thermo-Electrometer.—(See Appendix—*Electrometer, Thermo.*)

Thermo-Multiplier.—A thermopile.

Thermo Pair.—(See Appendix—*Pair, Thermo.*)

Thermo-Phone.—An electrical instrument for producing sounds by means of electrically produced heat.

Thermostatic. — Of or pertaining to a thermostat.

Thermo-Telephone. — (See Appendix—*Telephone, Thermo.*)

Thermotic, Electro — —Of or pertaining to heat produced by electricity.

Thimble Brush.—(See Appendix—*Brush, Thimble.*)

Thomson.—A name proposed for the unit of conductivity.

The term *thmo* is to-day generally employed for the unit of conductivity. The plan of employing the names of celebrated deceased electricians is a good one and should not be departed from, no matter how deservedly great the name of the living electrician.

Thomson's Bridge.—(See Appendix—*Bridge, Thomson's.*)

Three-Phase Armature.—(See Appendix—*Armature, Three-Phase.*)

Three-Phase Currents.—(See Appendix—*Currents, Three-Phase.*)

Three-Phase Generator.—(See Appendix—*Generator, Three-Phase.*)

Three-Phase Motor.—(See Appendix—*Motor, Three-Phase.*)

Three-Way Switch.—(See Appendix—*Switch, Three-Way.*)

Three-Way Trolley Switch.—(See Appendix—*Switch, Three-Way Trolley.*)

Throw, Concentration — —A term proposed by Squier for the deflection of a magnetic needle by a current produced under certain circumstances by a couple formed of similar plates of iron or other paramagnetic metals when exposed to chemical action while under the influence of a magnetic field.

The concentration throw is a phenomenon marking the reversal of the direction of current produced by a couple of paramagnetic metals when exposed to the action of a magnetic field. Squier has observed in the case of a couple formed of similar plates of iron exposed to the action of nitric acid while in a magnetic field, that under certain conditions the effect of suddenly putting on a magnetic field was to produce a less rapid deflection of the galvanometer in the opposite direction, so that the electrode which was formerly protected, by being the negative plate of the couple, was now the one acted on by becoming the positive plate.

It is the above phenomenon for which Squier proposes the term of concentration throw.

According to Squier, "The 'protective throw' is due to the actual attraction of the magnet for the ion, and is always in the direction to protect the more strongly magnetized parts, while the 'concentrated throw' is always in the opposite direction, and depends upon the distribution of the iron salts present in the solution, and the convection currents in the liquid. The concentration of the products of the reaction about the point, would tend to produce a ferrous reaction instead of a ferric reaction, and experiments show that a

higher electromotive force is obtained with cells in which a ferrous reaction takes place than with those in which a ferric reaction occurs, and this change in the character of the reaction produced by the concentration probably accounts, at least in part, for the increased electromotive force at the point."

Throw, Protective — —A term proposed for the protection afforded by a magnetic field to paramagnetic metals exposed to chemical action.

When two similar electrodes of iron, or other paramagnetic metals, are exposed to chemical action while under the influence of a strong magnetic field, they act as a voltaic couple and the direction of the current produced depends on the direction of the lines of magnetic force. In the case of iron exposed to the action of nitric acid, one electrode being in the shape of a pointed cylinder and the other in the shape of a disc, when the lines of magnetic force of the field coincide in the direction with the length of the disc, the current produced passes through the liquid from the disc to the electrode, that is, from the less magnetized electrode, to the more magnetized electrode, the presence of the magnetic field determining the direction of the current produced. In this, as in all similar cases of voltaic couples, the negative plate or electrode is protected from the chemical action, the positive plate alone being acted on.

The name protective throw is proposed by Squier for the protection so afforded, who has studied the phenomena. The proposed term would appear to be an unfortunate one, the protection not being afforded by the throw of the needle.

Tint-Electro.—A term proposed for a method of electric engraving.

Tip, Conducting Cord — —A blunted or rounded conductor placed at one of the ends of a wire for the purpose of readily inserting it into a binding post or into a hole in a plate.

Tip, Conducting Cord, Separable — —A cord and tip arranged so that the tip is readily detachable from the cord.

The method of attachment can be insured in a variety of ways. A screw thread forms one of the most obvious.

Tonicity, Electro — —A term sometimes employed for electrotonus. (See *Electrotonus*.)

Tool, Electric Machine — —A machine tool of any character driven directly by electric power.

In electric machine tools the motor is generally so placed that the moving power is thus connected directly to the machine instead of transmitted to it by means of belting. Among the many advantages possessed by electric machine tools is that such tools do away entirely with lines of shafting.

Top-Hat Curve.—(See Appendix—*Curve, Top-Hat*.)

Torque, Running, of Motor — —The torque exerted by a motor while running.

Torque, Starting, of Motor — —The torque exerted by a motor at the moment of starting.

The starting torque in a well-constructed motor, either of the alternating or continuous type, is always in excess of the torque it exerts at full load.

Total Contact.—(See Appendix—*Contact, Total*.)

Total Intensity of Earth's Magnetism.—(See Appendix—*Magnetism, Total Intensity of Earth's*.)

Touch, Divided — —A term sometimes employed in place of separate touch. (See *Touch, Separate*.)

Tourniquet, Electric — —A term sometimes employed in place of electric flyer. (See *Flyer, Electric*.)

Transference, Convection — —The transference of electricity in a liquid substance unattended by chemical changes in the liquid.

Convectiontransference of electricity appears to partake of the nature of atomic convection, the charge being carried by each atom or group of atoms in the direction in which the electricity is being transferred.

Transform.—To change or convert.

To convert or change the electromotive force and consequently simultaneously to change the current strength of the circuit by any means.

Strictly speaking, a transformer is regarded as changing the electromotive force. It therefore produces at the same time changes in the value of the current strength. When we speak of a step-down transformer we refer to a transformer which lowers or decreases the value of the electromotive force, although, of course, at the same time, it is employed to raise or increase the strength of the current.

Transformation.—The act of transforming or changing.

Transformation, as of Electromotive Force — —A change in the value of the electromotive force by means of an induction coil or transformer. (See *Transformer*.)

Electric power is equal to the product of the current by the electromotive force. By the use of a transformer the electromotive force, and consequently the current strength, are changed or altered in value. Since in a well-constructed transformer but very little energy is lost in transformation, the product of C E, in the primary very nearly equals the product of C' E', in the secondary. It follows, therefore, that as the electromotive force increases in the secondary, the current strength decreases and *vice versa*.

In the case of a transformer the transformation is directly proportional to the ratio of the number of turns of the primary and the secondary circuits.

Transformation, Current — —The act of changing the value of the current in any circuit by changes effected in its electromotive force. (See *Transformer*.)

The act of changing the character of the current, such, for example, as a direct into an alternating current or the reverse, or a single alternating current of short wave length and high frequency into triphase or polyphase currents.

It will be observed that the term current transformation is employed in two distinct senses.

Transformation of Electric Force.—(See Appendix—*Force, Electric, Transformation of*.)

Transformation, Ratio of — —The ratio between the electromotive force produced in the secondary of an induction coil or transformer and the electromotive force impressed on the primary.

The ratio of transformation depends on the relative number of turns of the secondary and primary coils of the transformer. In a well-constructed transformer there is very little energy lost in producing a transformation by means of mutual induction. Consequently the energy produced in the secondary must very nearly equal the energy that has been expended in the primary. Suppose, for example, that the number of turns of the secondary of an induction coil is one-fiftieth that of the primary; then the difference of potential induced in the secondary will be but one-fiftieth that impressed on the primary. In order to make the product of the current strength and the difference of potential in the secondary equal to the product of the current strength and difference of potential in the primary, the current strength in the secondary will have to be fifty times greater than the current strength in the primary; or, in other words, the product of C and E , in the primary will very nearly equal the product of C' and E' in the secondary, *i. e.*, $C E = C' E'$ nearly, assuming their lag factors to be equal.

Transformer, Alternating-Current Rotary — — A term sometimes employed for an alternating current motor which at the same time, by means of a suitable commutator, delivers continuous currents on a separate circuit.

Transformer, Closed-Circuit — — A term sometimes employed for closed-iron-circuit transformer. (See *Transformer, Closed Iron Circuit.*)

Transformer, Continuous Current — — A term sometimes used for motor-dynamo or dynamotor. (See *Transformer, Constant Current.*)

Transformer, Direct-Current Rotary — — A term sometimes employed for a motor-generator. (See *Generator, Motor.*)

Transformer, High-Frequency — — A transformer in which the frequency of the currents employed is high.

Transformer, Iron-Loss in — — A loss of energy in a transformer due to magnetic hysteresis or molecular magnetic friction and to the setting up of eddy or Foucault currents in the iron.

According to Steinmetz, there is no sensible magnetic viscosity in a transformer up to 204.5 complete periods per second. If the eddy or Foucault currents are excluded, the hysteresis loss of a transformer can, up to 200 complete periods per second, be exactly predetermined by calculations based on tests at slow cycles, magnetic viscosity being absent.

Transformer, Low-Frequency — — A transformer in which the frequency of the currents employed is low.

Transformer, Non-Polar — — A term sometimes employed in place of closed-iron-circuit transformer. (See *Transformer, Closed Iron Circuit.*)

Transformer, Open-Circuit — — A term frequently employed for open-iron-circuit transformer. (See *Transformer, Open Iron Circuit.*)

A variety of open-circuit transformer is shown in Fig. 582.

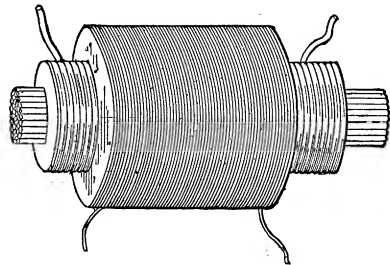

Fig. 582. Open-Circuited Transformer.

Transformer, Polar — — A term sometimes employed for open-circuit transformer. (See Appendix—*Transformer, Open-Circuit.*)

Transformer, Rotary — — A term generally employed for the combination of a motor and generator in one machine, *i. e.*, one armature and one motor.

Sometimes employed in place of a continuous current transformer. (See *Transformer, Constant Current.*)

The rotary transformer is employed either to transform continuous currents into continuous currents of different potential, in which case its armature contains two windings, the generator

winding and the motor winding, and the ratio of transformation is equal to the ratio of the turns of the two windings; or for converting alternate or polyphase currents into continuous currents, in which case if the maximum alternate current potential equals the continuous current potential, it generally contains one armature winding only, which is connected to the continuous current commutator, and at two, three or four equidistant points to collector rings.

Such rotary transformers are used extensively in long-distance power transmission for converting the alternating or polyphase currents into continuous currents for railway circuits, or for supplying alternating current circuits, or for electric welding.

The term rotary transformer should not be confounded with rotary current transformer. (See *Transformer, Rotary Current*.)

Transformer, Static — —A term sometimes employed for an ordinary transformer as distinguished from a rotary transformer. (See Appendix—*Transformer, Rotary*.)

Transforming.—Converting or changing the electromotive force and consequently the current strength in any circuit.

Transition Resistance.—(See Appendix—*Resistance, Transition*.)

Translating Telegraphic Station.—(See Appendix — *Station, Translating Telegraphic*.)

Translation Lag.—(See Appendix—*Lag, Translation*.)

Translation, Manual — —In telegraphy, especially in sub-marine telegraphy, the translation of a message from one circuit directly to another by an operator, who transmits to the second circuit, direct from signals received on the first, without writing down or transcribing the message.

Transmitter, Automatic Telegraphic — —An apparatus employed in a system of automatic telegraphy for sending or transmitting the prepared messages.

The message for automatic telegraphy is prepared by properly punching or perforating a slip or fillet of paper. This fillet is passed through a transmitter so as to transmit automatically.

Transposition.—In telephony a reversal in the relative position of two parallel conductors.

Transpositions are made in conducting wires in order to neutralize the electromotive forces produced by neighboring currents.

Trap, Burglar Alarm — —A spring burglar-alarm contact held in an open position by the pull of a string against the action of a spring.

The slightest disturbance of the spring draws the contact in one direction, and the destruction of the string permits the spring to draw it in the opposite direction, in either case insuring the closing of a circuit and the ringing of an alarm bell.

Treated Coked Filament.—(See Appendix—*Filament, Treated Coked*.)

Tree Insulator.—(See Appendix—*Insulator, Tree*.)

Tregalyn.—A term proposed by Houston and Kennelly for a million million dynes, or a million megadynes, or 10^{12} dynes.

Trega.—A prefix proposed by Houston and Kennelly for a million million or 10^{12} .

Tregerg.—A term proposed by Houston and Kennelly for a million million ergs, or a million megergs, or 10^{12} ergs.

Tregohm.—A term proposed by Houston and Kennelly for a million million ohms, or a million megohms, or 10^{12} ohms.

Triad Atom.—(See Appendix—*Atom, Triad*.)

Trico.—A term proposed by Houston and Kennelly for the million millionth part, or 10^{-12} .

Tricofarad.—A term proposed by Houston and Kennelly for the millionth part of a microfarad, or 10^{-12} farad.

Trigger, Door — —A device by means of which notice is given of the opening or closing of a door or window.

Trigger, One-Way Door — —A door trigger which operates on the opening of the door only.

Trigger, Two-Way Door — —A door trigger which operates both when the door is opened and when it is closed.

Trip, Door, Electric — —A device for ringing a bell so as to announce the entrance of a customer.

The bell is rung only when the door passes the trip, but does not ring when the door is opened, or when it is being closed.

Tri-Phase Armature.—(See Appendix—*Armature, Tri-Phase.*)

Tri-Phase Current. — (See Appendix — *Current, Tri-Phase.*)

Tri-Phase Generator.—(See Appendix—*Generator, Tri-Phase.*)

Tri-Phase Motor.—See Appendix—*Motor, Tri-Phase.*)

Triphased Alternating Currents.—(See Appendix—*Currents, Triphased, Alternating.*)

Turtle-Back Electro.—(See Appendix—*Electro, Turtle-Back.*)

Two-Phase Alternator.—(See Appendix—*Alternator, Two-Phase.*)

Two-Phase Armature.—(See Appendix—*Armature, Two-Phase.*)

Two-Phase Generator.—(See Appendix—*Generator, Two-Phase.*)

Two-Phase Motor.—(See Appendix—*Motor, Two-Phase.*)

Two-Pole Dynamo-Electric Machine.—(See Appendix—*Machine, Dynamo-Electric, Two-Pole.*)

Two-Thousand Candle-Power Arc, Definition for — —(See Appendix—*Arc, Two-Thousand Candle-Power, Proposed Definition for.*)

Two-Way Door Trigger.—(See Appendix — *Trigger, Two-Way, Door.*)

Triple-Pole Switch.—(See Appendix—*Switch, Triple-Pole.*)

Tri-Polar Indicator.—(See Appendix—*Indicator, Tri-Polar.*)

Trolley Base Frame.—(See Appendix—*Frame, Trolley Base.*)

Trough, Plating — —A term sometimes employed in place of plating bath. (See *Bath, Electro-Plating.*)

Tube, Lightning — —A fulgurite. (See *Fulgurite.*)

Tubular Current.—(See Appendix—*Current, Tubular.*)

Tuning of Electrical Circuit.—Altering the period of a circuit or varying the capacity or self-induction of the circuit so as to bring it into resonance with another circuit.

U

Uni-Phase Armature Winding.—(See Appendix—*Winding, Uni-Phase Armature.*)

Uni-Phase Motor.—(See Appendix—*Motor, Uni-Phase.*)

Unipolar Stimulation of Nerve.—(See Appendix—*Stimulation, Unipolar, of a Nerve.*)

Unit, C. G. S., of Volumetric Energy — —(See Appendix—*Energy, Volumetric, C. G. S. Unit of.*)

Unlighted Segment of Aurora.—(See Appendix—*Segment, Unlighted, of Aurora.*)

Unmarked Magnetic Pole.—(See Appendix—*Pole, Magnetic, Unmarked.*)

Unsymmetrical Polyphase Motor.—(See Appendix—*Motor, Polyphase, Unsymmetrical.*)

Upper Harmonics of Current.—(See Appendix—*Current, Upper Harmonics of.*)

V

V.—A symbol used for volt or for volume. The defining equation is $V = L \times L \times L$. The same symbol is also employed for volt.

v.—A symbol used for velocity.

The defining equation is $v = \frac{L}{T}$

The same letter is proposed as a symbol for volt. Its use should be limited to one or the other quantity.

v.—A symbol for the ratio between the units of resistance in the electrostatic and electromagnetic C. G. S. system of measurement; *i. e.*, for velocity ratio. (See *Ratio, Velocity*.)

Vacuum-Tube Lighting.—(See Appendix—*Lighting, Vacuum-Tube*.)

Variable Period of Telegraph Line.—(See Appendix—*Period, Variable, of Telegraph Line*.)

Variation Magnetometer.—(See Appendix—*Magnetometer, Variation*.)

Vector Potential.—(See Appendix—*Potential, Vector*.)

Verdet's Constant.—(See Appendix—*Constant, Verdet's*.)

Vertical Intensity of Earth's Magnetism.—(See Appendix—*Magnetism, Vertical Intensity of Earth's*.)

Vertical Magnetic Needle.—(See Appendix—*Needle, Vertical Magnetic*.)

Vibration Frequency.—(See Appendix—*Frequency, Vibration*.)

Vibrator.—An electromagnetic device provided on a siphon recorder for maintaining the siphon in continual vibration so that ink is thrown down upon the fillet of paper beneath.

Virtual Current.—(See Appendix—*Current, Virtual*.)

Visual Telegraphic Signal.—(See Appendix—*Signal, Telegraphic, Visual*.)

Volatilization of Electric Conductor.—(See Appendix—*Conductor, Electric, Volatilization of*.)

Volt, International — —The value of the international volt adopted by the Chicago Congress of 1893 as equal to such an electromotive force that, steadily applied to a conductor whose resistance is one international ohm, will produce a current of one international ampère, and which is represented sufficiently well for practical use by $\frac{1.1000}{1.1334}$ of the electromotive force between the electrodes of the voltaic cell known as Clark's cell, at a temperature of 15° C., and prepared in accordance with certain specifications.

Volt, Proposed A. I. E. E. Definition for — —The product of the A. I. E. E. ampère by the A. I. E. E. ohm.

Volt-Ammeter.—A term proposed for any electric instrument capable of measuring either the volts or the ampères in a circuit, or both.

A measurer of the volt-ampères or the watts.

A wattmeter.

The word wattmeter would appear to be preferable.

Volta-Electric.—Of or pertaining to voltaic electricity. (See *Electricity, Voltaic*.)

Volta-Electricity.—Voltaic electricity. (See *Electricity, Voltaic*.)

Volta-Electrometer.—A voltameter. (See *Voltameter*.)

Volta-Electrometric.—Producing voltaic electricity. (See *Electricity, Voltaic*.)

Volta-Electromotive Force.—(See Appendix—*Force, Volta-Electromotive*.)

Volta-Plast.—A word proposed for the voltaic battery employed in electrotyping.

The use of this word would appear to be entirely unnecessary. There is nothing peculiar about this employment of the voltaic battery.

Volta-Type.—A word proposed for electrotype.

The use of this word would appear to be entirely unnecessary. The word electrotype is preferable.

Voltagraphy.—Electrotypy.

The word electrotypy would appear to be far preferable.

Voltaic Battery, Element of — (See Appendix—*Element of Voltaic Battery.*)

Voltaic Bow.—(See Appendix—*Bow, Voltaic.*)

Voltaic Cell, Callan — (See Appendix—*Cell, Voltaic, Callan.*)

Voltaic Cell, Maynooth — (See Appendix—*Cell, Voltaic, Maynooth.*)

Voltaic Electromotive Force.—(See Appendix—*Force, Electromotive, Voltaic.*)

Voltaic Endosmose.—(See Appendix—*Endosmose, Voltaic.*)

Voltaic Heat Cell.—(See Appendix—*Cell, Voltaic Heat.*)

Voltaic Magnet.—(See Appendix—*Magnet, Voltaic.*)

Voltaic Pair.—(See Appendix—*Pair, Voltaic.*)

Voltaism.—A word sometimes employed in electro-therapeutics for treatment by means of the voltaic current.

The production of electricity by means of voltaic couples.

The latter use of this word was the meaning given to it by Sturgeon in 1842, who defined it as follows: "The production of electricity by the association of metals and other organic bodies by the simple contact of inorganic bodies."

Voltmeter, Electrometer — —A voltmeter in which the difference of potential to be measured charges insulated conductors, the electrostatic attractions and repulsions of which produce a deflection of a suitably suspended metallic needle.

A term frequently employed for voltmeter. (See *Electrometer. Voltmeter.*)

Voltmeter, Galvanometer — —Any form of galvanometer so arranged as to readily measure difference of potential.

A term sometimes employed for a galvanometer.

Galvanometer-voltmeters may be constructed in a great variety of forms.

In all such cases, however, the difference of potential is measured by the deflection of a needle of a galvanometer by means of the magnetic field produced by the current which flows through a conductor connecting the two points whose difference of potential is to be measured.

In any galvanometer-voltmeter a magnetic field produced, as above described, by the difference of potential which is to be measured, may deflect a magnetic needle against the following forces, namely:

- (1.) Against a magnetic field. (See Appendix—*Voltmeter, Magnetic.*)
- (2.) Against the action of a spring. (See Appendix—*Voltmeter, Spring.*)
- (3.) Against the action of gravity acting on a weight. (See Appendix—*Voltmeter, Weight.*)

Voltmeter, Magnetic — —An instrument in which the magnetic field of a current, which is proportional to the difference of potential to be measured, deflects a movable needle against the action of the field of a magnet. (See *Voltmeter.*)

Voltmeter, Spring — —An instrument in which the magnetic field of a current, which is proportional to the difference of potential to be measured, deflects a movable needle against the action of a spring. (See *Voltmeter.*)

Voltmeter, Weight — —An instrument in which the magnetic field of a current, which is proportional to the difference of potential to be measured, deflects a movable needle against the action of a weight. (See *Voltmeter.*)

Volume Density of Charge.—(See Appendix—*Charge, Volume Density of.*)

Volumetric Energy.—(See Appendix—*Energy, Volumetric.*)

W

W.—A contraction used for the physical quantity energy, whether it be electrical, thermal, mechanical or chemical, or, in general, to represent the product of the force by the distance.

W.—A symbol used for electric energy.

The defining equation is $W = C E T$.

The same letter is proposed as the symbol for work and moment of a couple.

W.—A symbol proposed for the moment of a couple.

This letter is also employed as the symbol for work.

The defining equation is $F \times D$.

w. h.—An abbreviation proposed for watt-hour, the practical unit of electric energy.

Wand, Electric — —A term sometimes used for an electrophorus in the form of a torch.

An electric wand is employed for gas lighting by a spark produced by means of a small static machine in the handle upon the electrophorus.

Watchman's Electric Clock.—(See Appendix—*Clock, Electric, Watchman's.*)

Water-Gramme Degree.—(See Appendix—*Degree, Water-Gramme.*)

Watt-Efficiency of Secondary Battery.—(See Appendix—*Battery, Secondary, Watt-Efficiency of.*)

Watt, International — — The value of the international watt, adopted by the Chicago Congress of 1893, is equal to 10^7 units of power in the C. G. S. system, and which is the work done at the rate of one joule per second.

Watt, Proposed A. I. E. E. Definition for — —The product of the square of the A. I. E. E. ampère and the A. I. E. E. ohm.

Waves, Hertzian — —A term sometimes employed for electro-magnetic waves.

Waves in the ether that are produced by oscillatory discharges passing through a circuit or by a magnetic circuit undergoing variations in its

magnetic intensity. (See *Electricity, Hertz's Theory of Electro-Magnetic Radiation, or Waves.*)

Way Lease. — (See Appendix — *Lease, Way.*)

Weber, A. I. E. E. Definition for — — A name proposed for the practical unit of magnetic flux,

A unit of magnetic flux having the value of one absolute unit or line.

This unit is a modification of that proposed by a Sub-Committee of the American Institute of Electrical Engineers on Provisional Programme for the International Electrical Congress held in Chicago, U. S. A., in 1893, on the occasion of the World's Columbian Exposition.

The term weber was formerly applied to the unit of current; it never, however, came into very extensive use in the United States.

Wedge Cut-Out.—(See Appendix—*Cut-Out, Wedge.*)

Weeding-Out of Harmonics.—(See Appendix—*Harmonics, Weeding-Out of.*)

Weeding-Out of Harmonics by Electrical Resonance.—(See Appendix—*Harmonics, Weeding-Out of, by Electrical Resonance.*)

Weight Voltmeter.—(See Appendix—*Voltmeter, Weight.*)

Wheel, Barker's — —A term sometimes applied to a Barker revolving contact breaker. (See Appendix—*Breaker, Contact, Barker's Revolving.*)

Whirl, Contracting Magnetic — —A magnetic whirl which is decreasing or moving in towards the electro-magnet or circuit which is producing it.

When variations occur in the strength of the magnetism produced by variations in the strength of the current, expanding or contracting whirls are produced around the conductor which move outwards or from the conductor when the strength of the magnetism is increasing, and inwards or towards the conductor when such strength is decreasing. These whirls produce

electro-magnetic waves in the surrounding ether which are called Hertzian electro-magnetic waves. (See *Whirl, Expanding Magnetic Electricity, Hertz's Theory of.*)

Whirls, Electro-Dynamic — —A whirling or rotary motion produced in a cloud of copper oxide in a voltmeter when traversed by a powerful electric discharge while under the influence of a magnetic field.

The direction of the rotation is opposite to the hands of a watch before a north magnetic pole and in the same direction as the hands of a watch before a south pole.

Winding, Differential — —A —ny double winding of the magnet coils such that the two fields produced thereby are opposed to each other.

Winding, Single-Phase Armature — —A uni-phase armature winding.—(See Appendix—*Winding, Uni-Phase Armature.*)

Winding, Uni-Phase Armature — —The winding of the armature of a motor such as to enable it to be operated by uni-phase currents.

Windings, Phase — —The separate windings on the armature of a polyphase motor. (See Appendix—*Motor, Polyphase.*)

Windmill, Electric — —A term sometimes employed in place of electric flyer. (See *Flyer, Electric.*)

Window or Blind Contact.—(See Appendix—*Contact, Window or Blind.*)

Wire, Annunciator — —Insulated wire suitable for use in connection with annunciators, or other similar purposes.

Wire, Double Bronze — —A conducting wire furnished with an aluminium-bronze core and a copper-brass envelope.

A double bronze wire possesses great tensile strength, extreme toughness, and a comparatively low electrical resistance.

A No. 11 standard gauge double bronze wire has a breaking strain of 850 pounds and a resistance of 443 ohms per mile at 60 degrees Fahr.

Such a wire is so tough that it will stand from eight to ten bends of 180 degrees each in alternate directions through a radius of 5 millimetres.

Wire, Idle, of Armature — —A term sometimes employed in place of dead wire. (See *Wire, Dead, of Armature.*)

Wire, Idle, of Armature of Dynamo — —A term applied to that part of the wire on the armature of a dynamo-electric machine in which no useful electromotive force is produced.

The dead wire on an armature. (See *Wire, Dead, of Armature.*)

Wire, Idle, of Armature of Motor — —A term applied to that part of the wire on the armature of a motor in which the field produced by the driving current never exercises useful action in driving the motor, in so far as no counter electromotive force is generated in it.

Wire or Conductor, Balancing — —A term sometimes employed for a neutral wire or conductor of a three-wire system.

Wire, Tap, in Quadruplex Telegraphy — —The intermediate wire or conductor, in a system of quadruplex telegraphy, which divides the battery into two unequal parts, called respectively the long end and the short end.

Wires, Equalizing — —Two wires or conductors, one of which is employed for connecting the two positive brushes and the other for connecting the two negative brushes of two compounded dynamos when coupled in parallel.

In general, wires or conductors employed for equalizing electrical pressure or difference of potential in two or more circuits.

In the coupling of two compound-wound dynamos, the equalizing wires are connected one to the two positive brushes and the other to the two negative brushes of the coupled machines. By these means the electrical pressure or difference of potential at the terminals of the two dynamos is made equal, and consequently the currents in the two fields are also made equal.

Wires, Slinging — —A term sometimes employed in electro-plating for the wires or conductors by which the articles that are to be electro-plated are hung from the kathode in the plating bath.

Wiring, Concentric — —Wiring by means of concentric cables. (See Appendix—*Cable, Concentric*.)

Working Current of Motor.—(See Appendix—*Current, Working, of Motor*.)

Working, Direct, of Telegraphic Sounder — —A term sometimes employed for the method in which a telegraphic sounder is operated by means of the current received from the line wire or conductor from the distant station in contradistinction to the method where the receiving instrument is operated by means of a local battery.

Working, Double-Current Telegraphic — —A term sometimes employed for double-current signaling. (See *Signaling, Double-Current*.)

Working Efficiency of Telegraphic Circuit.—(See Appendix—*Circuit, Telegraphic, Working Efficiency of*.)

Working, Polyphase — —A general term employed to express the actual application of polyphase currents.

In polyphase currents the armature of the motor is provided with separate sets of coils grouped in two's, three's, etc., and put successively into action at suitable periods.

Working, Single-Current Telegraphic — —A term sometimes employed for single-current signaling. (See *Signaling, Single-Current*.)

Writing Telegraph.—(See Appendix—*Telegraphy, Writing*.)

Y

Y Tri-Phase System.—(See Appendix—*System, Y Tri-Phase*.)

Yards, Ampère — —The product of the

current in ampères by the distance in yards through which it passes. (See *Feet, Ampère, Turn, Ampère*.)

Z

Zero, Immediate False — —A term employed in Wheatstone bridge measurements for an observation made to that position of the galvanometer needle as zero, which is assumed, or which tends to be assumed, immediately after the opening of the circuit of the testing current.

Zinc-Lead Accumulator.—(See Appendix—*Accumulator, Zinc-Lead*.)

Zone, Neutral, of Electrically Charged Insulated Conductor — —That portion of an insulated conductor, charged by electrostatic induction, which lies approximately midway between its positive and negative ends.

Zone, Neutral, of Magnet — —A term sometimes employed for equator of magnet. (See *Magnet, Equator of*.)

APPENDIX B.

A

- A.**—A symbol for ampere (Partly International usage).
- A. or An.**—A contraction for anode.
- a.**—A symbol proposed for acceleration.
- α .**—A symbol for an angle.
- A. B. C. Telegraph Instrument.**—A step-by-step dial telegraph instrument marked with the letters of the alphabet.
- A. C.**—A contraction for alternating current.
- A. C. C.**—A contraction for anodic closure contraction.
- A. D. C.**—A contraction for anodic duration contraction.
- A. H.**—A contraction for ampere-hour.
- A. H. E.**—A contraction for ampere-hour efficiency.
- A. O. C.**—A contraction for anodic opening contraction.
- A. T.**—A contraction for ampere-turn.
- A. W. G.**—A contraction for American wire gauge.
- Abnormal Dispersion.**—Anomalous dispersion.
- Abnormal Earth-Current.**—A temporary, stronger, and more variable earth current than usual.
- Abnormal Magnetization.**—Magnetization generally in concentric layers of alternate polarity, produced by oscillatory or Leyden-jar discharges. (Obsolete.)
- Abnormal Vapor - Densities.**—Vapor densities whose values do not appear to conform to Avogadro's hypothesis.
- Abreast.**—Connected in multiple or parallel.
- Abscissa.**—The co-ordinate of a point measured along the axis of abscissas.
- Absolute.**—(1) Complete in itself. (2) Not dependent on secondary bases.
- Absolute Block System for Railroads.**—A block system in which one train only is permitted to occupy a given block, or division of the road, at any one time.
- Absolute Calibration.**—The determination of the absolute reading of an electrometer, galvanometer, voltmeter, ammeter, or other instrument.
- Absolute Electro-Dynamometer.**—An electro-dynamometer for the measurement of electric currents in C. G. S. units by reference to the moment of a bifilar suspension and constants derived from the winding of the coils.
- Absolute Electrometer.**—An electrometer in which the value of the electromotive force is directly determined in absolute units from the deflection of its movable index.
- Absolute Expansion.**—The real expansion of a liquid, or the expansion it would have independently of any change in the dimensions of its containing vessel.
- Absolute Galvanometer.**—Any galvanometer whose indications are directly determined in absolute units of current.
- Absolute Inductivity.**—The real inductivity of a medium as distinguished from the ratio of its inductivity to the inductivity of vacuum.
- Absolute Insulation.**—The total insulation of a circuit or conductor without reference to its length.
- Absolute Permittivity.**—The real permittivity of a medium as distinguished from the ratio of its permittivity to the permittivity of vacuum.
- Absolute Photometric Standard.**—A term for a fundamental standard of light employed in photometric measurements, in contra-distinction to a secondary standard.
- Absolute Unit of Current.**—(1) A current of such a strength that when passed through a wire one centimetre in length, bent in the form of an arc of a circle one centimetre in radius, will act with a force of a dyne on a magnetic pole of unit strength placed at the centre of the arc.
(2) A current of 10 amperes.

Absolute Unit of Electromotive Force.—(1) The C. G. S. unit of electromotive force. (2) The one-hundred millionth of a volt.

Absolute Unit of Inductance.—A length equal to one centimetre. (2) The one billionth (10^{-9}) part of a henry.

Absolute Unit of Induction.—A term sometimes used for the absolute unit of inductance.

Absolute Unit of Magnetomotive Force.—A unit of magnetomotive force equal to 4π multiplied by unit current of one turn.

Absolute Unit of Resistance.—(1) The one thousand millionth of an ohm. (2) A microhm.

Absolute Units.—The centimetre-gramme-second system of units.

Absolute Vacuum.—(1) A space from which all traces of residual gas have been removed. (2) A term sometimes loosely applied to a high vacuum.

Absolute Zero of Temperature.—(1) The temperature of a substance in which its molecules are absolutely at rest, or possess no kinetic energy. (2) A temperature of approximately -273°C .

Absorption.—The taking in or drinking in of one form of matter by another, such as a gas, a vapor, or a liquid by any substance, usually a solid; or of energy of sound, light, heat or electricity by ordinary matter.

Absorption Current.—The current of diminishing strength which flows into a dielectric under electrification, and which is partly capable of being restored during continued discharge.

Absorption Dynamometer.—The name given to a dynamometer in which mechanical power is measured and at the same time absorbed, in contradistinction to a transmission dynamometer, in which the power to be measured is all or nearly all transmitted.

Absorption, Electric.—The apparent soaking of an electric charge into the glass or other solid dielectric of a Leyden jar or condenser.

Absorption of Sound.—Acoustic absorption.

Absorption Spectrum.—A spectrum containing gaps or dark spaces due to absorption by some medium which the radiation has traversed.

Absorptive.—Possessing the power of absorption.

Absorptive Power.—The power possessed

by certain substances of taking in and condensing gases within their pores.

Acceleration.—(1) The time-rate of change of velocity. (2) Increase or decrease of velocity.

Accumulated Electricity.—Stored electricity, as in a condenser.

Accumulating Electricity.—Storing electricity.

Accumulation of Electricity.—(1) The collection of an electric charge in a Leyden jar or condenser. (2) The increase in an electric charge by devices called accumulators. (3) The production of a charge by an influence machine. (4) The collection of electric energy by storage batteries or accumulators.

Accumulator.—(1) A word sometimes applied to a current accumulator. (2) A Leyden jar or condenser. (3) A secondary or storage battery.

Accumulator Distribution.—Distribution of electric energy by means of accumulators.

Accumulator Traction.—Car traction in which the motors are driven by storage batteries carried on the car.

Acetometer.—(1) A hydrometer graduated for determining the strength of commercial acetic acid or vinegar. (2) An acidometer.

Acheson Effect.—The change in the electromotive force of the secondary of a transformer due to changes of temperature in its core.

Achromatic.—Free from false coloration.

Achromatic Lens.—A lens capable of forming images free from false coloration.

Achromatic Ocular.—An achromatic eye-piece.

Achromatisable.—Capable of being freed from false coloration.

Achromatise.—To free from false coloration.

Achromatising.—Freeing from false coloration.

Acidimeter.—An acidometer.

Acidometer.—A hydrometer for measuring the specific gravity of an acid liquid, and thereby determining its degree of acidity.

Aclinic.—(1) Of or pertaining to no magnetic inclination. (2) Devoid of magnetic inclination or dip.

Aclinic Line.—(1) A line connecting places on the earth's surface which have no magnetic inclination. (2) The magnetic equator of the earth.

- Acoustic.**—Of or pertaining to sound.
- Acoustic Absorption.**—The absorption by a vibrating body, of the energy of the sound waves produced by another vibrating body.
- Acoustic Interference.**—Interference of sound waves.
- Acoustic Resonance.**—(1) The increase in the intensity of the sound emitted by a sonorous body by means of sympathetic vibrations set up in a co-periodic sounding body. (2) The condition by virtue of which a sonorous body is capable of having sympathetic vibrations produced in it by a neighboring sounding body.
- Acoustic Synchronizer.**—An instrument for indicating the synchronism of two alternating currents or alternators, by an acoustic apparatus in which silence is produced at synchronism.
- Acoustic Telegraph.**—Any telegraph whose signals are appreciated by the ear, as distinguished from a visual telegraph.
- Acoustic Telegraphy.**—Sound telegraphy; or, any system of telegraphy in which the signals are received by sound, in contradistinction to being received visually.
- Acoustic Tetanus.**—Tetanus produced by alternating currents from an induction coil, when its contact piece is vibrating with sufficient rapidity to produce a musical note.
- Acoutemeter, Electric.**—An apparatus for electrically testing the delicacy of hearing.
- Actinic.**—Of or pertaining to the chemical effect produced by light or other form of radiant energy.
- Actinic Photometer.**—A photometer in which the intensity of light is measured by the amount of chemical decomposition it produces.
- Actinic Ray.**—A ray of light, or other form of radiant energy, possessing the power of producing chemical action.
- Actinism.**—The chemical effects of light.
- Actino-Electricity.**—Electricity produced in crystalline substances by the action of radiant energy.
- Actinograph.**—An apparatus for measuring and recording the intensity of the chemical effects of light.
- Actinography.**—The method of producing records by the chemical effects of light.
- Actinometer.**—(1) An apparatus for measuring the intensity of the chemical effects of light. (2) A pyrheliometer.
- Actinometer, Electric.**—An apparatus for electrically measuring the intensity of the chemically active rays present in any radiation.
- Actinometry.**—The science of measuring the intensity of the chemical effects of radiant energy.
- Action Currents.**—Physiological currents produced in a muscle or nerve during its activity.
- Active Coil or Conductor.**—A coil or conductor carrying an electric current.
- Active Component of Exciting Current.** (1) The active current in an alternating-current circuit as distinguished from the wattless current. (2) In an alternating-current circuit the component of current which is in phase with the E. M. F. (3) In an alternating-current circuit the product of the E. M. F. and the effective or apparent conductance.
- Active Current.**—(1) The working component of a current in an alternating-current circuit as distinguished from the wattless component of current. (2) The component of an alternating-electric current that is in phase with the impressed electromotive force.
- Active Electromotive Force.**—In an alternating-current circuit that component of the impressed electromotive force which is expended in overcoming the ohmic resistance, as distinguished from the component which is expended in overcoming the induced C. E. M. F.
- Active Loop.**—Any single loop in a circuit that is traversed by an electric current.
- Active Mass.**—In electrolysis the quantity of an electrolyte which is disassociated into its ions, and which is, therefore, active in conveying the electrolyzing current.
- Active Material of Storage Cell.**—The substance or substances in a storage or secondary cell, that undergo decomposition while charging or discharging, and which serve to store the electric energy.
- Active Molecules.**—(1) Those molecules in an electrolyte that, during the passage of an electric current, are resolved into their constituent ions and which, therefore, alone affect the molecular conductivity of the electrolyte. (2) The disassociated molecules in an electrolyte.
- Active Plate of Voltaic Cell.**—A name sometimes given to the zinc or other plate of a voltaic or primary cell which is dissolved during action.
- Active Polar Surface of Magnet.**—That

- surface of a magnet from which the useful flux emerges, or into which it enters.
- Active Pressure.**—In an alternating-current circuit that component of the impressed pressure which is expended in overcoming the ohmic resistance.
- Active Pressure.**—A term sometimes employed for the pressure that is effective in producing a current, as distinguished from the impressed pressure.
- Active Wire.**—That portion of the wire on the armature of a dynamo or motor that is passed through the inducing magnetic flux as distinguished from the remainder of the wire sometimes called "idle wire," which does not pass through such flux.
- Activity.**—(1) Power. (2) Rate-of-doing-work. (3) The work done per second, in uniform working.
- Actual Caution.**—A caution produced by the agency of a white heat.
- Actual Energy.**—(1) Energy actually employed in doing work, as distinguished from energy that, though possessing the power of doing work, is in the latent or potential state. (2) Kinetic energy.
- Actual Efficiency.**—Commercial efficiency.
- Acute Angle.**—Any angle less than a right angle or 90 degrees.
- Acute-Angled Trolley-Crossing.**—A contact plate suspended at the point of intersection of two trolley wires crossing at an acute angle.
- Acylic Region.**—(1) A region devoid of cyclosis. (2) A simply connected region.
- Adapter.**—(1) A screw-nozzle fitted to an incandescent electric lamp and provided with a screw-thread to enable it to be readily placed on a gas bracket, or chandelier, in the place of an ordinary gas burner. (2) A device which permits incandescent electric lamps of one manufacture to be readily placed in the socket of a lamp of another manufacture. (3) Apparatus designed to permit the ready use of a continuous-electric current employed for incandescent lighting to produce the feeble continuous currents employed in electro-therapeutic work.
- Adherence.**—The quality or property of adhesion.
- Adhesion.**—The mutual attraction which exists between unlike molecules, as distinguished from the attraction of like molecules, or cohesion.
- Adhesion, Electric.**—The adhesion between surfaces due to the attraction of unlike electrostatic charges.
- Adhesion, Magnetic.**—The adhesion between surfaces due to magnetic flux.
- Adhesive Tape.**—A tape covered with insulating material and possessing adhesive properties, employed for covering bared conductors, at joints, or other similar places.
- Adiabatic Expansion.**—The expansion of a gas which neither receives nor gives out heat to the walls of the chamber in which the expansion takes place, as distinguished from isothermal expansion.
- Adiathermancy.**—Opacity to heat.
- Adiathermanic.**—Of or pertaining to adiathermancy.
- Adielectric.**—(1) Not dielectric. (2) A term proposed for substances, not dielectrics, whose electric conductivity at ordinary temperatures decreases as the temperature increases.
- Adjustable Angle Crossing.**—A form of trolley crossing in which the angle of intersection is adjustable.
- Adjustable Condenser.**—A condenser whose capacity can be readily varied within certain limits.
- Adjustable Resistance.**—A resistance whose value can be readily varied within certain limits.
- Adjustable Rheostat.**—An adjustable resistance.
- Adjustable Vacuum Tube.**—A vacuum tube employed for X-ray work whose vacuum can be decreased by the action of heat on a vaporizable substance.
- Adjustable Wire Clip for Trolley Wire.**—A clip, capable of adjustment as to its position, inserted in an insulator and designed for holding a trolley wire in place.
- Adjuster for Lamp Pendant.**—Any device for adjusting or altering the height or position of a pendant lamp.
- Adjusting Cleat.**—Any cleat that is capable of adjustment as to alignment or height.
- Adjustment.**—Any regulation of an apparatus that will enable it properly to perform its functions.
- Adjustment of Relay.**—Such a regulation of a receiving relay as will permit it to readily respond to signals sent over the line.
- Admittance.**—(1) The reciprocal of the impedance in an alternating-current circuit. (2) The apparent conductance of an alternating-current circuit or conductor.
- Advanced Quadrature.**—In an alternat-

- ing-current circuit the condition of being 90° in phase ahead of some particular E. M. F., flux, or current.
- Adynamic System of Currents.**—A system of currents so opposed to each other in direction as to neutralize one another's magnetic effects.
- Aeolotropic.**—Heterogeneous with respect to direction.
- Aeolotropic Medium.**—(1) A medium possessing different properties in different directions. (2) A medium in which equal stresses applied in any direction do not produce equal strains.
- Æpinus' Condenser.**—An early form of air condenser.
- Aerial Cable.**—An electric cable suspended in the air.
- Aerial Circuit.**—(1) That portion of a circuit which consists of aerial conductors or lines. (2) Δ circuit of overhead wire.
- Aerial Conductor.**—An overhead conductor.
- Aerial Line.**—An overhead line.
- Aerial Telephone Cable.**—A suitably supported overhead telephone cable.
- Aerodromic Transportation.**—Transportation by means of a balloon-supported car over a suitable support guide.
- Aerodynamics.**—The science which treats of the forces produced by air in motion.
- Aero-Ferric-Circuit Transformer.**—An open-circuit transformer.
- Aero-Ferric Inductance.**—The inductance possessed by a coil or coils whose magnetic circuit consists partly of air and partly of iron.
- Aero-Ferric Magnetic Circuit.**—A magnetic circuit that is completed partly through air and partly through iron.
- Aerolite.**—A meteorite.
- Aero-Therapeutics.**—Treatment of disease by means of air under pressures other than that of the atmosphere.
- After Currents.**—Electric currents produced in nerve or in muscular tissue, on the cessation of a constant current which has been flowing through it.
- After Glow of Exhausted Bulb.**—A fluorescent glow, observed in an exhausted glass chamber, after its withdrawal from electrostatic influence.
- Age-Coating of Electric Incandescent Lamp Chamber.**—A blackening of the chamber of an electric incandescent lamp due to the deposit thereon, during use, of carbon, or other opaque substance.
- Ageing of Alcohol, Electric.**—Artificially ageing alcohol by exposing it to the action of electrically generated ozone.
- Ageing of Electric Incandescent Lamp.**—A gradual decrease in the efficiency of an electric incandescent lamp due either to the age coating of its chamber, or to the deterioration of its filament.
- Ageing of Magnet.**—Treating a permanent magnet for the purpose of rendering its magnetic condition more permanent.
- Ageing of Transformer.**—(1) A decrease in the efficiency of a transformer owing to the ageing of its core. (2) Fatigue of transformer.
- Ageing of Transformer Core.**—Increase in the hysteretic coefficient in the iron of a transformer core, during the first few months of its commercial operation, from its continued magnetic reversals at comparatively high temperature.
- Agglomerate Leclanché Cell.**—A form of Leclanché cell which dispenses with the porous cup by employing the carbon and black oxide of manganese formed into a solid mass by pressure.
- Agitator for Plating Vat.**—A device for ensuring a uniformity in the density of the plating solution in a depositing vat, by mechanical stirring.
- Agonal.**—Of or pertaining to an agone.
- Agone.**—(1) A line connecting places on the earth's surface where the magnetic needle points to the true geographical north. (2) The line of no declination.
- Agonic.**—Of or pertaining to an agone.
- Agonic Line.**—(1) A line connecting terrestrial points having no declination or variation. (2) The agone.
- Air Battery.**—A form of voltaic battery whose electromotive force is increased by the direct absorption of oxygen from the air.
- Air Blast for Commutator.**—A jet of air applied to the surface of the commutator of a dynamo-electric machine to prevent destructive flashing.
- Air-Blast Transformer.**—A transformer which is cooled by a blast of air.
- Air Churning.**—The movement of the air that occurs in the vicinity of the armature of a dynamo or motor during rotation resulting in a loss of energy to the machine.
- Air Condenser.**—A condenser in which air is the dielectric.
- Air-Cooled Transformer.**—(1) A transformer which is cooled by the passage through it of convection currents of air set up by its increase of temperature. (2) An air-blast transformer.

Air-Core Solenoid.—A solenoid which has no core other than air.

Air-Core Transformer.—A transformer which is destitute of a core other than that of air.

Air-Expansion Lightning Arrester.—A form of lightning arrester in which the arc, when formed, is blown out by the expansion of a mass of confined air under the influence of the heat of the arc.

Air Field.—That portion of a magnetic field in which the magnetic flux passes through air only.

Air Film of Lamp Chamber.—A film of condensed air that tends to remain on the walls of an exhausted lamp chamber after the action of the air pump.

Air Gap.—In a magnetic circuit, any gap or opening containing air only.

Air Gap of Commutator.—The air space between contiguous segments in an air-insulated commutator.

Air Insulation.—An insulation obtained by air, or by the action of air.

Air Leyden.—An air condenser.

Air-Line Wire.—That portion of a circuit which consists of overhead wires, in contradistinction to the portion which passes through underground conduits, or through a submarine cable.

Air Magnetic Circuit.—A magnetic circuit in which the flux passes wholly through air.

Air Path.—The path a disruptive discharge takes through the air.

Air Pump.—A device for removing air or other gas from a containing vessel.

Air Reluctance.—The reluctance of that portion of a magnetic circuit which consists of air.

Air Resistance of Dynamo.—The mechanical resistance to the rotation of a dynamo due to the surrounding air.

Air Space.—(1) The space that exists between the surface of an armature and the polar surface within which it rotates. (2) The space between opposed surfaces of a comb lightning-arrester.

Air-Space Cut-Out.—A modified form of paper cut-out in which the disc of paper or mica is replaced by an air-space.

Air-Space Submarine Cable.—A multiple-conductor submarine cable, having a core in which an internal air space is provided for separating the conductors.

Air Telegraphy.—(1) Aerial telegraphy. (2) Induction telegraphy. (3) Wireless telegraphy.

Air-Washing of Lamp Filament.—A deleterious effect produced on the filament of an incandescent electric lamp by the molecular bombardment of the residual gaseous atmosphere of its chamber.

Alarm, Electric.—(1) Any automatic electric device by which attention is called to the occurrence of certain events, such as the opening of a door or window, the stepping of a person on a mat or staircase, the rise or fall of temperature beyond a certain predetermined point, etc., by the closing or opening of an electric circuit. (2) A device for calling a person to a telegraphic or telephonic instrument.

Alarm Point.—In a system of fire telegraphy, any point from which an alarm is sent out.

Alarm Wires of Submarine Cable.—Extra insulated wires imbedded in the fibrous serving of a submarine cable, between the sheathing wires and the conductor core, and capable of giving an alarm when their insulation is affected through injury to the cable, before the working conductor or central core may be injured.

Aligned Magnetomotive Force.—The magnetomotive force in a magnetic circuit containing iron, due to the aligning of the molecular magnets of the iron under the influence of the impressed magnetic force or prime flux.

“Alive.”—(1) A name sometimes given to a live wire or circuit. (2) An active wire or circuit.

All-Day Efficiency of Transformer.—The ratio of the energy commercially supplied by a transformer in 24 hours to the energy absorbed by it from the mains during that time.

All-Night Arc Lamp.—A double-carbon arc lamp.

Allotropic.—Of or pertaining to allotropism.

Allotropic State.—A modification of a substance by means of which, without any change in chemical composition, it acquires physical or chemical properties differing from those it ordinarily possesses.

Allotropism.—The state or condition resulting from acquiring the allotropic state.

Allotropy.—The property of, or capacity for, acquiring the allotropic state.

Alloy.—A combination or homogeneous mixture of two or more metallic substances.

Alloy.—To form a combination or homogeneous mixture of two or more metallic substances.

Alphabetic Telegraph.—(1) A telegraph in which the letters of the message to be sent are spelled out in succession from a dial. (2) An A, B, C, telegraph.

Alteration Theory of Muscular or Nerve Currents.—A theory which traces the origin of electric currents in the nerves or muscular fibres to an alteration from their original condition.

Alternate Currents.—Alternating currents.

Alternating.—Periodically changing in direction.

Alternating Arc.—(1) An alternating-current arc. (2) An arc supplied from an alternating-current circuit.

Alternating Continuous-Current Commutating Machine.—A secondary generator for transforming from alternating to continuous currents by the aid of a commutator.

Alternating-Current Arc.—A voltaic arc produced by alternating electric currents.

Alternating-Current Armature-Winding.—An armature winding suitable for the production of alternating currents.

Alternating-Current Dynamo-Electric Machine.—A dynamo-electric machine producing alternating currents in its external circuit.

Alternating-Current Electric Motor.—A motor driven by alternating electric currents.

Alternating-Current Electro-Magnet.—An electro-magnet whose coils are traversed by alternating currents, and which, although constantly reversing in magnetism, yet possesses a continued attraction for its armature.

Alternating-Current Phase-Meter.—An apparatus for measuring the difference between the phases of two alternating currents.

Alternating-Current Potentiometer.—A potentiometer suitable for measuring the difference of pressure in an alternating-current circuit.

Alternating-Current Power.—(1) Electric power supplied through the medium of alternating currents. (2) The product of the effective alternating-current strength, the effective pressure under which that current is supplied, and the power factor. (3) With sinusoidal electromotive forces and currents, the product of the effective current strength,

the effective pressure under which that current is supplied, and the cosine of the phase-difference between the two.

Alternating-Current Pressure Indicator.—An alternating-current voltmeter.

Alternating-Current Regulator.—(1) A regulator for maintaining constant the pressure of an alternating-current generator. (2) A regulator for controlling the strength of an alternating current.

Alternating-Current Rotary Transformer.—A rotary transformer for transforming alternating into continuous-currents, or *vice-versa*.

Alternating-Current Transmission.—Transmission of power or energy by means of alternating currents.

Alternating-Current Rush.—(1) A term sometimes applied to the first rush or wave of alternating current passing into the primary coil of a transformer at the moment it is connected to the mains. (2) A term sometimes applied to the oscillatory discharge of a condenser.

Alternating-Current Working.—Feeding lamps, motors, or other receptive devices by means of alternating currents.

Alternating Currents.—(1) Currents which flow alternately in opposite directions. (2) Currents whose directions are periodically reversed.

Alternating Discharge.—(1) A discharge which periodically changes its direction. (2) An oscillatory discharge.

Alternating Dynamo-Electric Machine.—An alternating-current dynamo-electric machine.

Alternating Electromotive Forces.—Electromotive forces whose directions are periodically reversing.

Alternating Electrostatic Field.—A field of electrostatic flux whose direction is periodically reversing.

Alternating Electrostatic Potential.—An electrostatic potential whose value is periodically changing sign.

Alternating Influence Machine.—An electrostatic influence machine which delivers periodically alternating electric discharges or currents.

Alternating Magnetic Field.—A magnetic field the direction of whose flux periodically changes.

Alternating Magnetic Potential.—A magnetic potential whose value is periodically changing sign.

Alternating Magnetic Call-Bell.—A

- call-bell operated by the uncommuted currents of a magneto-electric machine.
- Alternating Magneto-Electric Machine.**—A magneto-electric generator that produces alternating currents in its external circuit.
- Alternating Potential.**—A potential, whether electrostatic, electric, or magnetic, that is periodically changing in sign.
- Alternating Sparking Distance.**—The air space across which an alternating-current disruptive-discharge would pass.
- Alternation.**—(1) A change in direction. (2) A change or reversal in the direction of an electromotive force or current. (3) A single vibration or oscillation as distinguished from a complete cycle or double vibration.
- Alternation of Current.**—A change in the direction of a current.
- Alternations.**—Successive changes in the direction of a current or electro-motive force.
- Alternative Air-Path of Magnetic Flux.**—In a ferric magnetic circuit a field, outside the iron of the circuit, through which a portion of the magnetic flux passes.
- Alternative Path.**—The path or circuit taken by an impulsive discharge through an insulator in preference to a conducting path or circuit, of enormously smaller ohmic resistance, open to the discharge.
- Alternator.**—The name generally given to an alternating-current dynamo or generator.
- Amalgam.**—A combination or mixture of a metal with mercury.
- Amalgam, Electric.**—A substance with which the rubbers of the ordinary frictional electric machine are covered.
- Amalgamate.**—To form into an amalgam.
- Amalgamating.**—Forming into an amalgam.
- Amalgamating Solution.**—A solution of a salt of mercury employed for readily amalgamating the zincs of a voltaic battery.
- Amalgamation.**—The act of forming into an amalgam or effecting the combination of a metal with mercury.
- Amalgamation of Zinc.**—Coating the surface of the zinc of a voltaic cell with mercury.
- Amalgamator, Electric.**—An electrically driven amalgamator for the treatment of gold or silver ores with mercury.
- Amazite.**—The name given to a particular kind of insulating material.
- Amber.**—A resinous substance generally of a transparent yellow color.
- American Morse Code.**—The Morse telegraphic code employed in America, as distinguished from that employed in other parts of the world.
- American System of Telegraphy.**—The Morse system of telegraphy as employed in America.
- American Telegraphic Code.**—The American Morse code of telegraphic signals.
- American Twist Joint.**—A joint between two conducting wires in which each end is twisted around the other.
- American Wire Gauge.**—The name generally given to the Brown and Sharpe wire gauge, in which the largest wire, No. 0000, has a diameter of 0.467, the wire No. 36, 0.0057, and all other diameters are in geometrical progression.
- Ammeter.**—Any form of galvanometer which is capable of measuring current strength directly in amperes.
- Ammeter Panel of Switchboard.**—In a central station the panel of the switchboard which carries the principal ammeter or ammeters.
- Ammunition Hoist, Electric.**—An electrically operated hoist employed for raising ammunition to the gun deck or turret of a ship.
- Amorphous.**—Possessing no definite crystalline form.
- Amperage.**—The number of amperes passing in a circuit in a given time.
- Ampere.**—(1) The practical unit of electric current. (2) A rate of flow of electricity transmitting one coulomb per second. (3) The current of electricity which would pass through a circuit whose resistance is one ohm, under an electro-motive force of one volt. (4) A current of such a strength as will deposit 1.118 milligrammes of silver per second from a specifically prepared solution of silver nitrate.
- Ampere-Arc.**—A single conductor, bent in the form of an arc of a circle, and used in an electric balance for measuring current.
- Ampere-Balance.**—A balance form of ammeter which measures currents of a few amperes, or which determines a current strength of one ampere.
- Ampere-Centimetre.**—A proposed unit of magnetic flux equal to the flux pro-

- duced by one ampere flowing through a circuit one centimetre in length.
- Ampere-Foot.**—A unit of current strength multiplied by the distance to which said current is carried, employed in calculating the fall of electric pressure in distributing mains. (2) The magnetic flux or flux density developed in a coil.
- Ampere-Hour.**—(1) A unit of electrical quantity equal to the quantity of electricity conveyed by one ampere flowing for one hour. (2) A quantity of electricity equal to 3600 coulombs.
- Ampere-Hour Efficiency of Storage Battery.**—(1) In a cycle of charge and discharge, the ratio between the ampere-hours taken out of a storage battery and the ampere-hours put into it. (2) The quantity efficiency of a storage battery as distinguished from the energy efficiency.
- Ampere-Hour Meter.**—A meter which is capable of measuring an electric supply in ampere-hours.
- Ampere-Hour Output of Storage Battery.**—The amount of useful electric quantity produced by a storage battery in ampere-hours.
- Ampere-Meter.**—An ammeter.
- Ampere-Minute.**—A unit of electrical quantity equal to the electric quantity conveyed by one ampere in one minute.
- Ampere-Ring.**—A word sometimes used for ampere-turn.
- Ampere-Second.**—(1) A unit of electric quantity equal to the quantity of electricity conveyed by one ampere flowing for one second. (2) A coulomb.
- Ampere-Stream in Armature.**—The aggregate current in amperes produced by all the conductors on a dynamo armature.
- Ampere-Tap.**—In a system of electric distribution a tap provided in a branch circuit for carrying off a current of one ampere.
- Ampere-Turn.**—A unit of magneto-motive force equal to that produced by one ampere flowing around a single turn of wire.
- Ampere-Volt.**—A word sometimes used for volt-ampere, or watt.
- Ampere-Yard.**—A proposed unit of electric current multiplied by distance through which said current is carried, sometimes employed in calculations.
- Ampere-Winding.**—A word sometimes used for ampere-turn; *i. e.*, a single winding or turn through which one ampere passes.
- Ampere-per-Square-Centimetre.** — A unit of density of current expressed in amperes-per-square-centimetre of normal cross-section of conductor.
- Ampere-per-Square-Inch.**—A unit of density of current expressed in amperes per-square-inch of area of normal cross-section of conductor.
- Ampere's Rule for Deflection of Needle.**—The north-seeking pole of a magnetic needle is deflected by a current to the left-hand of an observer who is supposed to be swimming in the current while facing the needle.
- Ampere's Theory of Magnetism.**—A theory or hypothesis which ascribes the cause of magnetism to the presence of electric currents in the ultimate particles of a magnet.
- Amperian Currents.**—The electric currents that are assumed, in the Amperian theory of magnetism, to flow in closed circuits around the ultimate particles of a magnet.
- Amphigenic Charge.**—A name proposed for an electric charge, whose surface density varies in sign.
- Amplitude of Galvanometer Swing.**—(1) In a series of ballistic galvanometer deflections, the half sum of the deflection or elongation from zero, on one side of the scale, and the means of the preceding and following elongations on the other side. (2) When referred to radian measure the ratio of the above quantity to the distance of the scale from the mirror.
- Amplitude of Simple-Harmonic Motion.**—The maximum cyclic value of a simple-harmonic or simple-periodic vibration; or, the distance in a straight line from the median position to the position of greatest elongation.
- Amplitude of Vibration or Wave.**—The extent of the excursion of a simply vibrating particle on either side of its vibrating point or point of rest.
- Amyl-Acetate Standard.**—(1) A photometric standard lamp of definite dimensions burning amyl-acetate. (2) The Hefner-Alteneck standard lamp.
- Amyloid.**—(1) A substance employed in the manufacture of incandescent lamp filaments produced by the action of sulphuric acid on cellulose. (2) Parchmentized cellulose.
- Amyloid Filament.**—An incandescent lamp filament made from amyloid.
- Anæmic Cataphoresis.**—Cataphoretic medication accompanied by the application of bandages to retard local circulation in the parts treated.

Anæsthesia.—Insensibility to pain.

Anæsthesia, Electric.—Nervous insensibility obtained by electrical means.

Analogous Pole.—In a pyro-electric substance like tourmaline, the pole that acquires a positive electrification while the temperature of the crystal is rising.

Analysis.—The determination of the composition of a compound substance by separating it into the elementary substances of which it is composed.

Analysis, Electric.—The determination of the composition of a compound substance by electric means.

Analyzable.—Capable of being analyzed.

Analyze.—To separate into component parts.

Analyzer, Electric.—A gridiron of metallic wires which is transparent to perpendicularly incident electro-magnetic waves, when the length of the wires is perpendicular to the electric oscillations, but is opaque to them, that is, possesses the ability to absorb or reflect them, when rotated 90° from its former position; *i. e.*, when parallel to the electric oscillations.

Analyzing.—Separating into component parts.

Anaphoresis.—A term sometimes applied for the electric osmose which occurs in the neighborhood of the anode.

Anchor.—In a trolley system the diagonal tie wires which bind the trolley wire longitudinally to adjacent poles in order to maintain a uniform degree of tension in the trolley wire.

Anchor Log.—A log partially buried in the ground and serving as an anchor for a telegraphic pole.

Anchor Platform.—A frame-work attached to an anchor-pole by means of which the pole is solidly set in the earth.

Anchor Pole.—(1) A pole for overhead wires of sufficient stiffness to take the entire tension at points where an abrupt angle occurs, or where the conductors enter underground conduits. (2) A terminal pole.

Anchor-Ring Core.—A toroidal core.

Anchor Strain-Ear.—In an overhead trolley system a trolley ear or insulator employed for anchoring the trolley wire, or maintaining it taut, so as to ensure good and continuous contact with the trolley wheel.

Anchored.—(1) Kept in position by means of an anchor strain-ear. (2) Kept in position by means of an anchor, as a buoy or ship. (3) Maintained in a given position.

Anchored Filament.—An incandescent lamp filament supported at its centre to prevent injury to it by excessive vibration.

Anelectric.—A word formerly applied to conducting substances which it was believed could not be electrified by friction. (Obsolete.)

Anelectrotonic State.—The state or condition of electrotonus.

Anelectrotonic Zone.—The polar zone.

Anelectrotonus.—The decreased functional activity which occurs in a nerve in the neighborhood of the anode or positive electrode.

Anemograph.—A recording anemometer.

Anemograph, Electric.—An electrically recording anemometer.

Anemometer.—An apparatus for recording the intensity and direction of the wind.

Anemometer, Electric.—An apparatus for electrically recording the intensity and direction of the wind.

Anemometry.—The measurement of the direction and intensity of the wind.

Anemoscope.—An instrument which indicates but does not measure the intensity, or record the direction of the wind.

Aneroid.—Devoid of liquid.

Aneroid Barometer.—An apparatus for measuring atmospheric pressure, which operates by the to-and-fro movements of one of the walls of a partially exhausted elastic metallic box.

Angle.—The deviation of direction between two intersecting lines or planes.

Angle Cathetometer.—A cathetometer suitable for measuring angular deviation.

Angle of Declination.—(1) The angle which measures the deviation of the magnetic needle to the east or west of the true geographical north. (2) The angle of variation of a magnetic needle.

Angle of Dielectric Hysteretic Lag.—In a condenser traversed by an alternating current the angle whose tangent is equal to the ratio of the hysteretic conductance to the hysteretic susceptance of the condenser, or to the angle whose cotangent is the ratio of the hysteretic reactance of condensation to the hysteretic resistance of the condenser.

Angle of Dip.—(1) The angle which a magnetic needle, free to move in both a vertical and horizontal plane, makes with the horizontal line passing through its point of support. (2) The angle of inclination of a magnetic needle.

Angle of Hysteretic Advance of Phase.

The angle by which the equivalent sine wave of exciting current leads the sine wave of magnetism, in a transformer or choking coil containing iron.

Angle of Inclination.—The angle of dip.**Angle of Lag.**—The angle of lag of a dynamo-electric machine.

Angle of Lag of Current.—(1) An angle whose tangent is equal to the ratio of the inductive to the ohmic resistance in a circuit. (2) An angle whose cosine is equal to the ohmic resistance divided by the impedance of a circuit. (3) An angle whose cosine is the ratio of the real to the apparent power in an alternating-current circuit.

Angle of Lag of Dynamo-Electric Machine.—(1) The angle through which the axis of magnetization of the armature of a dynamo-electric machine is shifted by reason of the resistance its core offers to cyclic reversals of magnetization. (2) The angle through which the axis of magnetization of the armature of a dynamo-electric machine is shifted by reason of both hysteresis and armature reaction. (3) The backward angular deviation from the normal of the brushes of a motor in order to secure sparkless commutation.

Angle of Lead.—The forward angular deviation from the normal position which must be given to the collecting brushes on the commutator of a continuous-current generator in order to obtain quiet commutation.

Angle of Maximum Sensitiveness of Galvanometer.—The angle of deflection at which a given small alteration in the current strength produces the greatest deflection of the change in the needle.

Angle of Polar Span.—The angular distance which the pole pieces extend circumferentially around the armature bore.

Angle of Variation.—The angle of declination of the magnetic needle.

Angular.—Of or pertaining to an angle.

Angular Acceleration.—The time rate of change of angular velocity.

Angular Couple.—The angular force.

Angular Currents.—Currents flowing through circuits which intersect one another at any angle.

Angular Energy.—The product of one-half the square of the angular velocity and the moment of inertia.

Angular Force.—The force which causes the rate of change of angular momentum.

Angular Momentum.—The product of

the moment of inertia at any instant and the angular velocity.

Angular Torque.—The angular twist or couple.

Angular Velocity.—(1) The velocity of a point moving relatively to a centre of rotation or to some selected point, and usually measured in degrees per second, or in radians per second. (2) In a sinusoidal-current circuit the product of 6.2832 and the frequency of the current.

Angular Wire Gauge.—A wire gauge measurer formed of a metallic strip containing a tapering, or acute-angled slot with graduated edges.

Animal Electricity.—Electricity produced in the bodies of animals during life.

Animal Magnetism.—A term sometimes applied to hypnotism or artificial somnambulism.

Anion.—The electro-negative ion or radical of a molecule.

Anisotropic Conductor.—A conductor which though homogeneous in structure possesses different conductivities in different directions.

Anisotropic Medium.—(1) A medium in which equal stresses do not produce equal strains when applied in different directions. (2) An eolotropic medium.

Annealing.—The art of softening metals by heating and subsequent gradual cooling.

Annealing, Electric.—A process for annealing metals in which electric heat is substituted for ordinary heat.

Annual Inequality of Earth's Magnetism.—(1) A variation in any of the elements of the earth's magnetism dependent upon the relative position of the sun and earth. (2) Annual variations in the earth's magnetism.

Annual Load-Factor.—(1) The ratio between the mean output of a central station in one year, and the maximum output at any time during the year. (2) The ratio between the mean daily output of a central station in one year, and the mean daily maximum output in the same year.

Annual Variations of Magnetic Needle.—Variations in the magnetic declination that occur at regular periods of the year.

Annunciator Board.—A board on which annunciator clocks are placed.

Annunciator Drop, Electric.—A clock employed in connection with an annunciator for automatically disconnect-

- ing certain circuits at certain predetermined times.
- Annunciator Drop.**—An annunciator signal whose dropping indicates the closing or opening of the circuit of a particular electro-magnet connected therewith.
- Annunciator Wire.**—A class of insulated wire prepared for use in annunciator circuits.
- Anodal.**—Of or pertaining to the anode.
- Anodal Diffusion.**—A word sometimes used for cataphoretic medication.
- Anode.**—(1) The conductor or plate of a decomposition cell connected with the positive terminal of a battery or other electric source. (2) The terminal of an electric source out of which the current flows into the electrolyte of a decomposing cell or voltameter. (3) In a vacuum tube, electrolytic cell, bath, or receptive device, the terminal at which the current enters, as distinguished from the cathode, at which the current leaves.
- Anodic.**—Of or pertaining to the anode.
- Anodic Closure Contraction.**—The muscular contraction produced by the closing of a voltaic circuit, the anode of which is placed over a nerve, and the cathode at some other part of the body.
- Anodic Contraction.**—The muscular contraction produced in the neighborhood of the anode, either on opening or closing the circuit.
- Anodic Currents.**—In a polarized voltaic couple immersed in acidulated water, the electric currents produced by the agitation of the plate connected with the anode.
- Anodic Duration Contraction.**—The time during which a muscle continues contracted on the opening or closing of a circuit whose anode is placed over the part contracted.
- Anodic Electro-Diagnostic Reactions.**—The characteristic reactions which occur at the anode of an electric source placed over any part of a living body.
- Anodic Opening Contraction.**—The muscular contraction produced by the opening of a voltaic circuit the anode of which is placed over a nerve and the cathode at some other part of the body.
- Anodic Rays.**—The radiation claimed to emanate from the anode of an X-ray tube.
- Anodic Zone.**—The zone or region surrounding the anode when employed as a therapeutic electrode.
- Anodograph.**—A word proposed for a radiograph.
- Anomalous.**—(1) Irregular. (2) Not in accordance with the ordinary rule.
- Anomalous Dispersion.**—An abnormal dispersion in which the order of the wave frequencies is inverted as regards their order in ordinary dispersion.
- Anomalous Helix.**—A helix wound so as to produce an anomalous magnet.
- Anomalous Magnet.**—A magnet possessing more than two free poles.
- Anomalous Magnetization.**—(1) The magnetization produced by the oscillatory discharge of a condenser or Leyden jar. (2) Magnetization which produces more than two free poles in a magnet.
- Anomalous Pole.**—A name sometimes given to those poles of an anomalous magnet which consist of two similar adjacent poles.
- Anomalous Solenoid.**—An anomalous helix.
- Anomalous Spiral.**—An anomalous helix.
- Answer Back Signal.**—A return signal.
- Answering Call-Box.**—A call-box at which an answering signal is obtained, indicating that the call has been received at the central station.
- Answering Board.**—In a telephone switchboard the board holding the answering jacks.
- Answering Jacks.**—In any panel of a telephone switchboard the jacks connected with the subscribers whose calling drops are placed in that panel, so that each call may be immediately answered at an adjacent jack.
- Answering Key.**—In a telephone switchboard a lever contact key which enables the operator to bring her head telephone into connection with any subscriber.
- Anti-Cathode of X-Ray Tube.**—(1) A deflection plate placed opposite the cathode of an X-ray tube. (2) A platinum plate supported inside an X-ray tube to receive the cathodic bombardment.
- Anti-Conical System of Distribution.**—A system of conical conductors employed in anti-parallel feeding.
- Anti-Hum.**—A device for lessening the humming sound due to the vibration of an aerial wire.
- Anti-Induction.**—Opposing or preventing induction and its effects.
- Anti-Induction Cable.**—A cable whose conductors are so arranged as to avoid the effects of induction, either from themselves or from neighboring conductors.
- Anti-Induction Conductor.**—A con-

ductor constructed so as to avoid injurious inductive effects from neighboring circuits.

Anti-Induction Telephone Cable.—

(1) A telephone cable in which the conductors are so arranged as to neutralize the effects of induction produced by neighboring circuits. (2) A telephone cable in which the effects of electrostatic induction from neighboring circuits is avoided by a metallic covering or sheathing that is grounded at suitable intervals.

Antilogous Pole.—The pole of a pyroelectric substance like tourmaline, which acquires a negative electrification while the temperature of the crystal is rising.

Antimonious Lead.—An alloy of lead and antimony employed for the grid of a storage battery because it is not acted on by the charging current.

Antinode.—The point in a vibrating string, wire, or plate, midway between adjacent nodes.

Anti-Parallel Feeding.—A method of feeding in a system of parallel distribution in which the pressure at the terminals of all the translating devices is kept approximately uniform by employing mains tapering in opposite directions; that is, with their large ends connected to the generator terminals or bus-bars, and the mains proceeding in opposite directions around the circuit to be supplied.

Anti-phase.—(1) A phase relation between two periodic currents such that they tend to decrease the amplitude of the motion. (2) Phase opposition.

Anvil of Telegraph Key.—The front stop of a Morse telegraph key, upon which the lever descends in signalling.

Aperiodic.—(1) Not characterized by periodicity. (2) Devoid of periodicity. (3) Coming to rest steadily without oscillations.

Aperiodic Galvanometer.—(1) A galvanometer whose needle comes to rest without any oscillation. (2) A dead-beat galvanometer.

A-Pole.—A telegraph double-pole shaped like a letter A.

Apparent Electromotive Force.—The E. M. F. apparently acting in a circuit as measured by the drop of pressure due to the resistance of the circuit and the current strength passing through it.

Apparent Coefficient of Induction.—A term sometimes used for the apparent inductance in a circuit which either en-

velops iron, or is inductively associated with secondary circuits.

Apparent Coefficient of Magnetic Induction.—The apparent permeability of a substance as expressed by the amount of magnetic flux that passes through it per unit of normal cross-sectional area, differing from the true value on account of the presence of eddy currents.

Apparent Conductor-Resistance.—The impedance of a conductor which forms part of an alternating-current circuit containing both resistance and reactance.

Apparent Efficiency of Alternator.—The ratio of the electric activity delivered at the terminals of an alternator, as the product of volts and amperes supplied, to the activity mechanically absorbed at its pulley or shaft; in contradistinction to the efficiency determined from the true electric activity delivered.

Apparent Efficiency.—The efficiency of a generator, motor, or other apparatus, in an alternating-current circuit based upon the volt-amperes or apparent power as distinguished from efficiency based on real power.

Apparent Efficiency of Alternating-Current Motor.—The ratio of the power mechanically delivered by the motor to the apparent activity it receives at its terminals; as distinguished from the efficiency based upon the real electric activity received.

Apparent Energy.—(1) The product of the effective current and the effective pressure in an alternating-current circuit. (2) Apparent activity, as opposed to true activity. (3) In a sinusoidal-current circuit, or simple alternating-current circuit, the product of effective volts and effective amperes uncorrected for the cosine of the angle of their phase difference.

Apparent Expansion.—The increase in the volume of a liquid by expansion irrespective of the expansion of its containing vessel.

Apparent Insulation.—The insulation resistance of a circuit, uncorrected for the effect of leakage in the measuring current.

Apparent Impedance.—(1) In an alternating-current circuit the virtual impedance in a primary circuit due to the presence of an associated secondary circuit. (2) The joint impedance of a network of impedances.

Apparent Insulation of Telegraphic Line.—The insulation of a telegraph line

uncorrected for its conductor resistance, or for the drop in testing potential at the more remote portions.

Apparent Magnetization.—The magnetization due to the superposition of two separate magnetizations.

Apparent Power.—In an alternating-current circuit, the apparent watts, or the product obtained by multiplying the volts by the amperes, as read directly from a voltmeter and ammeter.

Apparent Reluctance.—The reluctance of a magnetic circuit, or portion thereof, under the influence of a complex of such superposed magnetic fluxes as may practically be developed, as distinguished from its reluctance under a single magnetising force.

Apparent Resistance.—The impedance in an alternating-current circuit or portion thereof.

Apparent Torque Efficiency.—In an alternating-current motor, the ratio of the torque actually developed to the torque which it would give at the same volt-ampere or apparent electric input in volt-amperes if there were neither internal losses nor phase displacement in the motor.

Apparent Watts.—The apparent power in an alternating-current circuit as distinguished from the real power.

Apron Grapnel.—A form of grapnel for grappling a cable in which the prongs are protected from breakage on rocks by an apron or covering, only a sufficient space being left between the apron and the prongs for the entrance of the cable.

Aqueous Solution.—A solution of a salt or other substance in water.

Arago's Disc.—A disc of copper or other non-magnetic metallic substance which, when rapidly rotated under a magnetic needle supported independently of the disc, causes the needle to be deflected in the direction of rotation, and, when the velocity of the disc is sufficiently great, to rotate with it.

Arborescent Discharges.—Disruptive discharges obtained from a high-potential discharge of a series-connected battery.

Arborescent Deposits.—Tree-shaped electro-metallurgical deposits.

Arc.—(1) A voltaic arc. (2) A portion of a circle, or other plane conic section.

Arc.—To discharge in the form of a voltaic arc.

Arc Ammeter.—An ammeter on an arc circuit.

Arc Blow-Pipe, Electric.—A blow-pipe

in which the air-blast is obtained by a convective discharge.

Arc-Circuit Cut-Out.—A cut-out placed in a series arc-light circuit to prevent the extinguishment of any lamp from breaking the entire circuit.

Arc-Circuit Cut-Out Box.—A box for holding an arc-circuit cut-out.

Arc-Circuit Indicator.—A device in the form of a simple galvanometer which indicates when the current is passing through an arc-light circuit.

Arc Crater Photometric Standard.—A photometric standard based on the intensity of light normally emitted from a definite area of the crater of a carbon voltaic arc.

Arc, Electric.—A term sometimes employed for the voltaic arc.

Arc-Lamp, Electric.—(1) An electric lamp whose source of light is the voltaic arc. (2) An incandescent electric lamp, employed to illumine the circles of telescopes or other instruments in an observatory.

Arc-Lamp Compensator.—A reactive or choking coil, placed in the circuit of a lamp or lamps for the purpose of automatically regulating the amount of current passing through the lamp or lamps.

Arc-Lamp Globe.—A glass globe surrounding the arc of an arc lamp.

Arc-Lamp Hand-Board.—An arc-lamp hanger-board.

Arc-Lamp Hanger.—A board from which an arc lamp is suspended, provided with electric connections for readily short-circuiting the lamp.

Arc-Lamp Spark-Arrester.—A gauze chimney surrounding the arc and employed for the purpose of preventing fires when arc lamps are placed near combustible materials, as in shop windows.

Arc-Lamp Suspension-Board.—(1) A board for suspending an arc lamp. (2) an arc-lamp hanger-board.

Arc-Light.—The light of the carbon voltaic arc.

Arc-Light Circuit.—(1) A circuit in which arc-lights are placed. (2) Generally, a series-connected circuit.

Arc-Light Cut-Out.—A switch for short-circuiting an arc-lamp and so cutting it out of the circuit. (2) A cut-out which automatically removes an arc-lamp from the circuit.

Arc-Light Diffuser.—Any diffuser for scattering or diffusing the light from an arc light so as to avoid the production of intense shadows.

- Arc-Light Generator.**—A dynamo-electric machine that furnishes current for arc-light circuits.
- Arc-Light-Points.**—The carbon pencils between which the arc is maintained in an arc light.
- Arc-Light Projector.**—An arc lamp provided with a reflector for obtaining a beam of approximately parallel rays of light.
- Arc-Light Meter.**—A form of electric current timer.
- Arc-Light Regulator.**—A device, generally automatic, for maintaining the carbons of an arc-lamp a constant distance apart during the operation of the lamp.
- Arc-Light Tower.**—A tower employed in out-door illumination for supporting a number of arc lamps.
- Arc-Light Transformer.**—A transformer which supplies alternating currents to arc-lamps.
- Arc-Lighter.**—An arc-light generator.
- Arc-Lighting.**—Artificial illumination obtained by means of arc lights.
- Arc-Lighting Dynamo-Electric Machine.**—An arc-light generator.
- Arc Plug-Switchboard.**—A switchboard provided with spring-jack contacts connected with the terminals of different circuits, and plug switches connected with the dynamo terminals, by means of which any dynamo can be connected with any circuit; or a number of circuits connected with the same dynamo; or a number of separate dynamos placed in the same circuit.
- Arc Micrometer.**—An apparatus for measuring the length of a voltaic arc by means of a micrometer.
- Arc Standard of Light.**—A photometric standard based on the intensity of the light emitted by a given area of crater of the positive carbon in a carbon arc.
- Arc Switchboard.**—An arc plug-switchboard.
- Arcing.**—Discharging by means of voltaic arcs.
- Areometer.**—An instrument for readily determining the specific gravity of liquids.
- Areometry.**—The measurement of the specific gravity of liquids by means of areometers.
- Argand Electric Burner.**—An Argand burner provided with a device for electrically igniting the gas.
- Argand Electric Lighter.**—An Argand electric burner.
- Argand Valve-Burner or Lighter.**—An Argand burner provided with means whereby the gas can be both turned on and lighted electrically.
- Argymometry.**—The art of determining the weight of electrically deposited silver.
- Arithmetical Mean Value of Periodic Current of E. M. F. Wave.**—The arithmetical average of all the instantaneous values during one complete period.
- Arm of Balance or Bridge.**—One of the resistances of an electric balance or bridge.
- Arms of Balance or Bridge.**—Two separate resistances, the value of one of which is usually a decimal multiple of the other, employed in an electric bridge or balance, in connection with a known resistance, to determine the value of an unknown resistance.
- Armature.**—(1) A mass of iron or other magnetizable material placed on or near the poles of a magnet. (2) The armature of a dynamo-electric machine.
- Armature Bars.**—(1) Heavy copper bars of rectangular or trapezoidal cross-section, or of imbricated rectangular strips, or of rectangular bars of compressed stranded wire, or of special forgings, employed on large drum armatures in place of the ordinary wire windings. (2) Heavy conductors employed for armature windings.
- Armature Binding Wires.**—Coils of wire bound on the outside of the armature wires for the purpose of preventing their separating from the armature core by centrifugal force.
- Armature Bore.**—The space between the pole-pieces of a dynamo or motor provided for the rotation of the armature.
- Armature Chamber.**—(1) The armature bore. (2) An armature pocket.
- Armature Chambers.**—Spaces left in the armature core for the reception of the armature coils.
- Armature Core-Discs.**—The thin discs of sheet-iron that form, when assembled, the laminated core of the armature of a dynamo or motor.
- Armature Core of Dynamo.**—The mass of laminated iron on which the armature coils or conductors of a dynamo or motor are placed.
- Armature Covering.**—A covering of canvas or other suitable material placed on an armature for the purpose of protecting its conductors from injury or dirt.

Armature Hole.—(1) The armature bore.
(2) A hole made in the core for the reception of an armature coil or winding.

Armature Inductors.—The bars, strips, or coils, placed on the dynamo armature core, in which electromotive forces are induced by rotation.

Armature Loop.—The single conducting coil or loop on a dynamo or motor armature.

Armature of Cable.—The sheathing or protective coat placed on the outside of a cable.

Armature of Condenser.—A term sometimes applied to the metallic plates or coatings of a condenser or Leyden jar.

Armature of Dynamo.—(1) Coils of insulated wire together with the iron core on or around which such coils are wound.
(2) That part of a dynamo in which useful differences of potential or useful currents are generated. (3) Generally that part of a dynamo which is revolved between the pole-pieces of the field magnets. (4) That member of a dynamo in which the magnetic flux is caused to successively fill and empty the coils and thereby generate E. M. Fs.

Armatures of Holtz Machine.—The pieces of paper that are placed on the stationary plate of a Holtz, or other similar electrostatic induction machine, near the openings in the same.

Armature Pinion.—A toothed wheel placed on the armature shaft of a street-car motor for engaging the teeth of the reducing gear.

Armature Pockets.—Spaces provided in an armature core for the reception of the armature coils.

Armature Projections.—Those portions of the armature core between which the armature slots, pockets, or chambers are situated.

Armature Reaction.—The reactive magnetic influence produced, by the current in the armature of a dynamo or motor, on the magnetic circuit of the machine.

Armature Segment.—That portion of an armature winding, or armature inductor, whose circuit is included between two contiguous segments of the commutator.

Armature Slots.—Slots provided in an armature core for the reception of the armature coils.

Armature Spider.—A metal frame-work, keyed to the armature shaft, and provided with radial arms for firmly holding the armature core.

Armature Stampings.—Stampings of soft sheet iron intended for the core discs of a laminated armature core.

Armature Turns.—The separate turns of conductors on the armature of a dynamo or motor.

Armature Varnish.—An insulating varnish sometimes applied to armature windings for the purpose of increasing their powers of resisting moisture and friction.

Armature Winding-Space.—Longitudinal grooves or spaces left in the armature core for the reception of the armature coils.

Armed Magnet.—A magnet provided with an armature.

Armor of Cable.—The protecting sheathing or metallic covering of a submarine or other electric cable.

Armored.—Provided with armor, as of the protective sheathing of a cable.

Armored Cable.—A cable provided with a protective sheathing or armor.

Armored Conductor.—A conductor provided with a protective sheathing or armor.

Army Telegraph.—The telegraphic apparatus employed in field service in the army.

Arrester Plate of Lightning Protector.—The ground-connected plate of a comb lightning-arrester.

Arrester Plates.—A term sometimes applied to the two plates of an ordinary comb lightning-protector.

Arrival Curve of Current in Submarine Cable or Telegraphic Circuit.—A curve showing the gradual increase in the strength of current reaching the receiving end of a submarine cable under a given condition of signaling.

Articulate Speech.—The successive tones of the human voice that are necessary to produce intelligible words.

Artificial Cable.—A circuit containing associated resistance and capacity, and employed in a system of duplex submarine telegraphy corresponding to the artificial line in duplex aerial line telegraphy.

Artificial Cable Leak.—A leak purposely introduced at some point in the circuit of an artificial cable employed in duplex cable telegraphy.

Artificial Carbons.—Carbons obtained by the carbonization of a mixture of pulverized carbon with a carbonizable liquid.

Artificial Fault in Cable.—A fault purposely made in an artificial cable for the purpose of studying its behavior under tests.

Artificial Illumination.—The employment of artificial sources of light.

Artificial Line.—In duplex telegraphy a combination of resistance coils and condensers which serves to balance an actual telegraph line.

Artificial Magnet.—A magnet produced by induction from another magnet or from an electric current.

Asbestos Porcelain.—A porous substance, somewhat resembling ordinary porcelain, employed for the porous cells of voltaic batteries.

A-Side of Quadruplex Table.—That side of a quadruplex system which is worked by means of reversed currents.

Asphyxia.—Suspended respiration eventually resulting in death from non-aeration of the blood.

Assumed Direction of Flow of Current.—A convention which regards the current as leaving an electric source at its positive pole, and returning to it at its negative pole.

Assymmetrical.—Devoid of symmetry.

Assymmetrical Resistance.—A resistance which is claimed to be greater to a flow of current in one direction than in another.

Astatic.—Devoid of magnetic directive power.

Astatic Circle.—A term sometimes used for astatic circuit.

Astatic Circuit.—A circuit, consisting of two closed curves enclosing equal surfaces, which is not deflected by the earth's field on the passage of a current through it.

Astatic Couple.—Two magnets of equal strength so placed one above the other in a vertical plane as completely to neutralize each other's effects.

Astatic Galvanometer.—A galvanometer provided with an astatic needle or circuit.

Astatic Multiplier.—An astatic galvanometer.

Astatic Needle.—(1) A compound magnetic needle of great sensibility, possessing little or no directive power. (2) An astatic needle consisting of two separate needles rigidly connected and placed parallel one directly over the other with opposite poles opposed.

Astatic Pair.—An astatic couple.

Astatic System.—An astatic combination of magnets.

Astaticizing.—Rendering a system astatic.

Astigmatism.—A defect in the lenses of the eye which prevents horizontal and vertical lines from being in focus at the same time.

Astronomical Meridian.—A great circle passing through any point of the heavens and the north and south poles of the heavens.

Asymptote of Curve.—A straight line which continually approaches a curved line, but which meets it only at an infinite distance.

Asynchronism.—Devoid of synchronism.

Asynchronous.—Occurring or acting non-simultaneously.

Asynchronous Alternating-Current Motor.—A motor whose speed is not synchronous with that of its driving generator, both machines having the same number of poles.

Atmosphere.—(1) A unit of gaseous or fluid pressure equal to 14.73 pounds per square inch. (2) The ocean of air which surrounds the earth.

Atmospheric.—Of or pertaining to the atmosphere.

Atmospheric Cathode Discharge.—An X-ray discharge which is assumed to accompany and form part of the sun's radiation.

Atmospheric Electricity.—The free electricity which is present in the atmosphere.

Atom.—(1) An ultimate particle of matter. (2) The smallest quantity of elementary or simple matter that can exist.

Atom of Electricity.—A quantity of electricity equal in amount to that possessed by any chemical monad atom.

Atomic.—Of or pertaining to the atom.

Atomic Attraction.—(1) The attraction which causes the atoms to combine. (2) Chemical affinity.

Atomic Capacity.—The equivalence or valency of an atom.

Atomic Currents.—A term sometimes employed instead of molecular or Amperian currents.

Atomic Energy.—Chemical potential energy.

Atomic Heat.—A constant product obtained by multiplying the specific heat of an elementary substance by its atomic weight.

- Atomic Weight.**—The relative weight of the atoms of elementary substances.
- Atomicity.**—(1) The combining capacity of the atoms. (2) The relative equivalence of the atoms, or their atomic capacity.
- Atomization.**—The act of obtaining liquids in a spray of finely divided particles.
- Atomize.**—To separate into a spray by means of an atomizer.
- Atomizer.**—An apparatus for readily obtaining a finely divided jet or spray of liquid.
- Attachment Plug.**—A plug provided for insertion in a screw socket or spring jack, for the ready connection of a lamp or other receptive device to a circuit.
- Attract.**—To draw together.
- Attracted-Disc Electrometer.**—A form of electrometer in which the force is measured by the attraction existing between two charged discs.
- Attracting.**—Drawing together.
- Attraction.**—Literally the act of drawing together.
- Attraction of Gravitation.**—(1) Mass attraction; or, the attraction which causes masses of matter to tend to move towards one another. (2) The attraction which causes bodies to fall to the earth. (3) Molar attraction.
- Attractions and Repulsions of Currents.**—The tendency of active circuits to be attracted to or repelled from one another by the mutual action of their magnetic fields.
- Audible Code.**—A term employed in railway signalling for a code of audible signals in railway service.
- Audible Telegraphic Signal.**—A signal which is received by the ear in contradistinction to a visual signal or one received by the eye.
- Audiometer.**—A form of induction balance or sonometer employed in testing the acuteness of hearing.
- Audiphone.**—A thin plate of hard rubber held in firm contact with the teeth and maintained at a certain tension by strings attached to one of its edges, employed for the purpose of aiding the hearing.
- Auger.**—A boring tool for cutting holes for telegraph poles.
- Aura, Electric.**—A term sometimes applied to an electric brush or convective discharge.
- Aural Electrode.**—An electrode suitably shaped for the therapeutic treatment of the ear.
- Aurora.**—(1) Luminous sheets, columns, arches, or pillars of pale flashing light, generally of a reddish color, seen in the Northern and Southern heavens. (2) The Northern and Southern lights.
- Aurora Australis.**—(1) The Southern light. (2) A name given to an appearance in the Southern heavens similar to that of the aurora borealis.
- Aurora Borealis.**—The Northern light.
- Aurora Glory.**—A term proposed for the almost constant crown or crowns of light, which occupy a nearly fixed position in the heavens during the continuance of an aurora.
- Aurora Polaris.**—A general name for the aurora borealis or the aurora australis.
- Auroral.**—Of or pertaining to an aurora.
- Auroral Arch.**—An arch-like form sometimes assumed by the auroral light.
- Auroral Bands.**—Approximately parallel streams of light that are sometimes seen during the prevalence of an aurora.
- Auroral Coronæ.**—Crown-shaped appearances sometimes assumed by the auroral light.
- Auroral Curtain.**—A curtain-shaped sheet of auroral light.
- Auroral Flashes.**—(1) Sudden variations in the intensity of the auroral light. (2) Intermittent flashes of auroral light.
- Auroral Light.**—The light given off by an aurora.
- Auroral Storm.**—An unusual prevalence of auroras.
- Auroral Streams.**—Auroral streamers.
- Auroral Streamers.**—Flashing columns or pillars of light that are emitted from portions of the sky during the prevalence of an aurora.
- Austral.**—Of or pertaining to the South.
- Austral Fluid.**—A term formerly employed for that magnetic fluid which was supposed to exist around or to emanate from the austral pole of a magnet.
- Austral Magnetic Pole.**—(1) The name formerly employed in France for the north-seeking pole of a magnet. (Not in general use.) (2) That pole of a magnet which points to the earth's geographical north. (Not in general use.)
- Auto-Car.**—(1) An automobile car. (2) A car provided with storage batteries.
- Auto-Converter.**—(1) A choking coil connected across a circuit and tapped at various points to enable a reduced E. M. F.

to be obtained. (2) An auto-transformer. (3) A choking coil connected to an induction motor by a switch in such a manner as to facilitate the starting of the motor under load.

Auto-Excitation.—Self-excitation.

Auto-Exciting.—Self-exciting.

Autographic Telegraphy.—(1) Facsimile telegraphy. (2) A writing telegraph.

Auto-Induction.—A word sometimes employed instead of self-induction.

Auto-Kinetic System of Fire Telegraphy.—A system of fire telegraphy in which the transmitters are connected in series in a pair of circuits, so that, when an alarm is being transmitted from one alarm point, no other alarm, received at the same time, will be transmitted until the first has been recorded.

Automatic Annunciator Drop.—An annunciator drop which on the closing of a distant circuit falls and holds the circuit closed until the drop is raised.

Automatic Answer-Back.—An automatic return-signal call-box.

Automatic Argand Burner.—An Argand burner furnished with a device by means of which it can be either automatically lighted or extinguished at a distance.

Automatic Gas Cut-Off.—A device for automatically cutting out the battery from an electric gas-lighting circuit, on the accidental grounding of the circuit.

Automatic Guard for Series-Connected Incandescent Lamps.—(1) An automatic cut-out, placed on a series-connected incandescent lamp, for the purpose of short-circuiting the holder should the lamp filament break. (2) A film cut-out.

Automatic Indicating-Grapple.—A grapple which automatically completes the circuit of an electric bell or indicator on a cable ship, as soon as the cable is hooked.

Automatic Indicator.—Any automatic device for electrically indicating the number of times a circuit has been opened or closed, thus showing the number of times any operation has occurred, which has caused the opening or closing of the circuit.

Automatic Indicator for Grapple.—An apparatus employed with a grapple for indicating when the grapple comes off the sea bottom.

Automatic Inker.—An ink-writing Morse

recorder which is automatically self-starting upon its operation by telegraphic currents.

Automatic Interrupter.—An automatic contact-breaker.

Automatic Locking-Switch.—A combined key and switch employed in submarine cables, whereby the switch is automatically locked and thus prevented from being left for sending, when it should be left for receiving, or *vice-versa*.

Automatic Make-and-Break.—A device whereby the to-and-fro movements of the armature of an electro-magnet are caused to automatically make and break its circuit.

Automatic Multiple-Transmitter.—In a telegraphic signalling or calling system, the means whereby the requisite number of spacing and electric impulses for any of a number of different calls, is automatically sent over a line, in order to produce a given signal, such for example, in a system of police telegraphy, as a call for an ambulance, a call for a squad, etc.

Automatic Oiler.—An oil cup or reservoir that automatically spreads oil over the bearing of a machine in motion.

Automatic Overload-Switch for Storage Battery.—An automatic electromagnetic switch, inserted in the discharging circuit of a storage battery, by means of which, when the discharging current exceeds a certain safe limiting strength, it is automatically opened.

Automatic Paper-Winder.—An apparatus for carrying and automatically winding the paper fillet or strip used on telegraphic registers.

Automatic Photo-Electric Switch.—A switch that is automatically opened or closed on the exposure of its face to differences of illumination.

Automatic Regulation of Dynamo-Electric Machine.—Such a regulation of a dynamo-electric machine as will automatically preserve constant, either the current strength or the potential difference at its terminals.

Automatic Regulation of Motor.—Such a regulation of a motor as will maintain constant its speed, or its torque.

Automatic Regulator.—A device for securing automatic regulation of a dynamo or motor, as distinguished from hand regulation.

Automatic Repeater.—A telegraphic repeater which is automatically operated, in contradistinction to a manual repeater which is operated or controlled by hand.

- Automatic Rheostat.**—An automatic variable resistance.
- Automatic Rheotome.**—An automatic contact-breaker.
- Automatic Ringing - Through.**—A means by which in junction telephone working the attention of the distant exchange can be secured by the act of establishing connection at the originating exchange without the necessity of calling up the distant exchange after connection has been made.
- Automatic Search-Light.**—A search-light in which a parallel, or slightly divergent beam of light, is caused automatically to sweep the horizon and thus disclose the approach of a torpedo boat or other similar danger.
- Automatic Signalling.**—Telegraphic transmission by machine-made contacts as distinguished from telegraphic signalling by hand.
- Automatic-Call-Box.**—A form of telephone call-box by means of which the service of a telephone exchange can be obtained by a payment made into a box, thus dispensing with the services of an attendant.
- Automatic Chemical Telegraphy.**—Automatic telegraphy in which the signals are recorded on a fillet or band of chemically prepared paper.
- Automatic Circuit-Breaker.**—A device for automatically opening a circuit when the current passing through it is excessive.
- Automatic Clearing Indicator.**—(1) A self-restoring drop. (2) A clearing indicator at a telephone exchange on a junction line, which automatically indicates when the conversation has terminated.
- Automatic Contact-Breaker.**—A device for causing an electric current to rapidly make and break its own circuit.
- Automatic Counter.**—In railway block-signalling, an electro-magnetic device for recording and indicating the signals of an audible code.
- Automatic Curb-Sender.**—In submarine telegraphy, a transmitter in which each signal is curbed automatically; *i. e.*, each signal is followed by one or more alternately directed impulses before earthing, for the purpose of clearing the line of its static charge.
- Automatic Cut-In.**—Any arrangement of parts that will automatically introduce a translating device or an electric source into a circuit on the occurrence of any predetermined event.
- Automatic Cut-Out.**—Any arrangement of parts that will automatically cut-out or remove a translating device or an electric source from a circuit on the occurrence of a predetermined event.
- Automatic Cut-Out for Storage Battery.**—An automatic electro-magnetic switch, inserted into the charging circuit of a storage battery, so arranged that if the charging current falls below a safe limiting strength the charging circuit will be opened.
- Automatic Cut-Out for Multiple-Connected Electro-Receptive Devices.**—(1) A device for automatically cutting an electro-receptive device, such as a lamp, out of a circuit. (2) A safety catch or safety base.
- Automatic Cut-Out for Series-Connected Electro-Receptive Devices.** Means whereby an electro-receptive device, such as an arc lamp, is to all intents and purposes automatically cut-out of, or removed from, a circuit, by means of a shunt of low resistance which permits the greater part of the current to flow past the lamp.
- Automatic Cut-Out of Magneto.**—A cut-out switch for automatically removing the armature of a magneto from the telephone circuit by the action of a spring, as soon as the handle is released.
- Automatic Drop.**—An automatic annunciator drop.
- Automatic Electric Alarm-Bell.**—An electric alarm-bell furnished with an automatic contact-breaker.
- Automatic Electric Bell.**—(1) A trembling or vibrating bell. (2) An automatic electric alarm-bell.
- Automatic Electric Gas-Burner.**—An electric device for both turning on the gas and lighting it, and turning the gas off, and thus extinguishing the light, by alternately touching different buttons.
- Automatic Electric Safety System for Railroads.**—A system for automatically preventing the approach of two trains, whatever their speed, beyond a predetermined distance from each other.
- Automatic Fire-Alarm.**—An instrument for automatically telegraphing an alarm of fire from any locality on its increase in temperature beyond a certain predetermined point.
- Automatic Fire-Annunciator.**—An annunciator for automatically indicating the point from which a fire-alarm has been sent.
- Automatic Steam-Whistle, Electric.**—

- A steam-whistle employed in absolute block systems for railroads, whereby, during fogs or snow-storms, when the signals are hidden from view, the locomotive, on passing over a portion of the road at a convenient distance from the signal, is caused to make a succession of electric contacts, whereby a steam whistle is blown on the moving train.
- Automatic Switch.**—(1) A switch which is automatically opened or closed on the occurrence of certain predetermined events. (2) In double-current telegraphy an electro-magnetic switch which enables the distant station to stop the sending operator at the home station.
- Automatic Switch for Incandescent Electric Lamps.**—(1) A safety fuse or safety cut-out. (2) Any switch by means of which incandescent lamps can be lighted or extinguished at a distance. (3) A device for automatically closing the circuit of a lamp or lamps on the opening of a door, or passage of a barrier. (4) A device for automatically opening the circuit of a lamp or lamps after the expiration of a predetermined time or at the closing of a door.
- Automatic Telegraph.**—A general term embracing the apparatus employed in automatic or machine telegraphy.
- Automatic Telegraph-Sounder.**—A form of automatic telegraphic transmitter.
- Automatic Telegraph-Transmitter.**—(1) A device for automatically transmitting signals by means of embossed or perforated slips drawn under suitable contact devices. (2) A transmitter employed in automatic telegraphy for sending prepared messages.
- Automatic Telegraphy.**—A system of telegraphy by means of which a telegraphic message is automatically transmitted over a line by the motion of a previously perforated fillet of paper, the perforations of which are arranged in the order and length required to form the characters to be transmitted.
- Automatic Telephone-Exchange.**—A system of telephony in which the subscribers are able to secure selective intercommunication without the aid of an exchange operator.
- Automatic Telephone Hook.**—An automatic telephone switch, operated by hanging up the telephone used in connection with it.
- Automatic Telephone Switch.**—(1) A device for automatically transferring the connection of the main line from the telephone to the call-bell by the weight of the telephone when hung up. (2) A switch operated by the act of hanging up or taking down a telephone from a hook and employed to introduce or remove a call-bell from the line.
- Automatic Time Cut-Out.**—A device which automatically cuts a translating device or an electric source from a circuit at a certain predetermined time, or after the lapse of a predetermined time.
- Automatic Variable Resistance.**—A resistance the value of which can be automatically varied.
- Automatically Regulable.**—Capable of automatic regulation.
- Automatically Regulate.**—To regulate in an automatic manner.
- Automobile.**—(1) Self-movable. (2) Containing the power necessary for its own motion.
- Automobile Carriage.**—A horseless carriage.
- Automobile Torpedo.**—A torpedo which contains the power required for its propulsion.
- Automobile Vehicle.**—An automobile carriage.
- Auto-Reversible Tele-Radiophone.**—(1) A photophone arranged so that a number of telegraphic communications may be simultaneously sent either all in the same direction, or part in one direction, and the remainder in the opposite direction. (2) A multiple tele-radiophone.
- Auto-Starter.**—(1) A self-starting mechanism. (2) A self-starting ink-writer. (3) A self-starting motor.
- Auto-Telephone System.**—A system of multiple-circuit telephony in which a single battery is employed, whereby a number of telephone stations can be connected by a single cable without the use of a distributing board, or exchange.
- Auto-Transformer.**—A one-coil transformer consisting of a choking coil connected across a pair of alternating-current mains, and so arranged that a current or pressure differing from that supplied by the mains can be obtained from it by tapping it at different points.
- Auxiliary Bus.**—A central-station busbar connected to an auxiliary pressure; *i. e.*, a pressure different from the main-station pressure.
- Auxiliary Alarm Telegraph.**—In a system of fire-alarm telegraphy, where an alarm received in any one circuit is automatically repeated over all the other cir-

cuts, means whereby the repetition of the signals are prevented from interfering with the incoming signals of any of the other circuits.

Average Efficiency of Motor.—(1) The efficiency of an electric motor based on its average or mean load. (2) The ratio of all the work that a motor delivers in a given time to the electric energy it has absorbed in that time.

Average Electromotive Force.—The mean electromotive force.

Average Life of Incandescent Lamp. The mean time during which a number of incandescent lamps will continue to burn without breaking when connected with a circuit of given pressure.

Average Value of Periodic Current or E. M. F.—The arithmetical mean value of a periodic current or E. M. F., with respect to magnitude and without respect to sign or direction.

Avogadro's Hypothesis.—Equal volumes of different gases measured at the same temperature and pressure contain the same number of molecules.

Axes of Co-Ordinates.—A vertical and a horizontal line, usually intersecting each other at right angles, and called respectively the axes of ordinates and abscissas, from which the ordinates and abscissas are measured.

Axial.—Of or pertaining to an axis.

Axial Current.—In electro-therapeutics, a current flowing in a nerve in the opposite direction to the normal impulse of the nerve.

Axial Magnet.—A name sometimes given to a solenoid with a straight core.

Axis of Abscissæ or Abscissas.—The horizontal line in the axes of co-ordinates.

Axis of Magnetic Needle.—A straight line drawn through a magnetic needle, and joining its poles.

Axis of Ordinates.—The vertical line in the axes of co-ordinates.

Azimuth.—In astronomy, the angle subtended at an observer between the plane of an azimuth circle and the plane of the meridian.

Azimuth Circle.—The arc of a great circle passing through the zenith, or the point of the heavens directly overhead, and the nadir, or the point directly beneath.

Azimuth Compass.—(1) A compass used for measuring the horizontal angular distance of any distant object from the magnetic meridian. (2) The mariner's compass.

Azimuth Telegraph.—On a war-ship a telegraph for indicating at any or all guns the azimuth of a target.

Azimuth and Range Telegraph.—On a war-ship a combined telegraph to the guns of the azimuth and range of a target.

B

♁.—A symbol for magnetic intensity, or induction density, usually expressed in C. G. S. units per normal square centimetre. (Partly International usage.)

B.—(1) A symbol for magnetic induction, or the amount of flux per normal square centimetre of the magnetized material. (2) A symbol for susceptance in alternating-current circuits.

B. A. Ampere.—The British Association ampere in a circuit whose resistance is one B. A. ohm under an E. M. F. of one B. A. volt.

B. A. Balance.—A type of balance or bridge, originally employed by the British Association Committee in duplicating B. A. ohms.

B. A. Ohm.—(1) The British Association ohm. (2) The resistance of a column of mercury one square millimetre in area of normal cross-section, and 104.9 centimetres in length, at the temperature of zero centigrade.

B. A. U.—A contraction for British Association unit or ohm.

B. A. Unit.—The British Association unit of resistance or ohm.

B. S. G.—A contraction for British standard gauge.

B. & S. W. G.—A contraction for Brown and Sharpe's wire gauge.

B. T. U.—(1) A contraction for British thermal unit. (2) A contraction for Board of Trade unit.

B. W. G.—A contraction for Birmingham wire gauge.

Back Ampere-Turns.—Ampere-turns on a dynamo armature which tend to oppose the flux produced by the field magnets.

Back Electromotive Force.—A term sometimes used for counter-electromotive force.

Back Induction.—An induction opposed to the field and tending to weaken or neutralize it.

- Back Magnetization.**—A term sometimes used for backward or back induction.
- Back Magnetization of Armature.**—Counter-magnetomotive forces acting in the main magnetic circuit of the field coils, and tending to reduce the useful flux passing through the armature.
- Back of Electro-Magnet.**—The yoke of an electro-magnet.
- Back Pitch.**—The backward pitch of the armature windings.
- Back Stroke of Lightning.**—The return stroke of lightning.
- Back Stop of Key.**—A stop placed on the back of a telegraph key in order to limit its motion in the direction of release.
- Back-Turns of Armature.**—(1) Those turns on an armature whose current tends to demagnetize the field. (2) The back ampere-turns.
- Backing Metal.**—An alloy that is placed on the back of the copper shell of an electrotype in order to stiffen it.
- Backing Pan.**—The pan in which the copper shell of an electrotype is placed in order to receive its backing of type metal.
- Backward Induction of Dynamo Armature.**—The component of the armature induction that opposes the induction of the field magnets.
- Backward Pitch of Armature Windings.**—A pitch which is always left-handed, or counter-clockwise, when regarded from the commutator side.
- Backward Waves.**—In a closed circuit supplied by a dynamo or other source of electromotive force, a wave of potential that is assumed to start from the negative pole of the dynamo and travel around the circuit in the opposite direction to the forward wave of positive potential from the positive pole of the dynamo.
- Bad Earth.**—A term sometimes applied to a bad ground, or a connection to earth whose electric resistance is comparatively high.
- Bain Telegraph Code.**—An old form of telegraphic alphabet originally employed in connection with the Bain printing instrument.
- Bain's Chemical Recorder.**—An apparatus for recording the dots and dashes of a telegraphic despatch on a sheet of chemically prepared paper.
- Bain's Chemical Solution.**—Bain's printing solution.
- Bain's Printing Solution.**—(1) The solution used in Bain's chemical recorder. (2) A solution of potassium ferrocyanide and water.
- Baking Oven, Electric.**—An electrically heated baking oven.
- Balance Arm.**—One of the arms of an electric balance.
- Balance Arms.**—The arms of an electric balance.
- Balance, Electric.**—A term sometimes used for an electric bridge.
- Balance Galvanometer.**—A dynamo galvanometer employed for indicating when the pressure of the dynamo is equal to the pressure on the bus-bars.
- Balance Indicator.**—Any device for indicating when an electric balance has been obtained.
- Balance Indicator of Three-Wire System.**—A device for indicating when a balance is obtained between the positive and negative leads of a three-wire system of distribution.
- Balance of Induction in Cable.**—The neutralization of induction in a cable by the presence of equal and opposite effects.
- Balance of Telegraphic Circuit.**—The condition of a duplexed telegraph line when the home relay ceases to respond to the home key.
- Balance Photometer.**—A photometer based on the decomposition of iodide of nitrogen by the action of light.
- Balanced Armature.**—(1) An armature whose weight is symmetrically distributed as regards its axis of rotation. (2) An armature that has been so adjusted by the addition of weights that its weight is symmetrically distributed with reference to its axis of rotation.
- Balanced Circuit.**—A telephonic, telegraphic, or other circuit which has been so erected and adjusted as to be free from mutual inductive disturbances from neighboring circuits.
- Balanced Load.**—A load which is symmetrically divided between two or more generating units, as in the three-wire, five-wire, multiple, or polyphase systems of distribution.
- Balanced Magnetic Circuits of Armature.**—The magnetic circuits traversing the armature of a dynamo-electric machine through which the magnetic fluxes produced by the field are symmetrically distributed in regard to flux density, total flux, and geometrical distribution.
- Balanced Metallic Circuit.**—A metallic

- circuit, the two sides of which have similar electric properties.
- Balanced Polyphase System.**—A polyphase system all the branches of which are symmetrical in regard to their electromotive force, current, and phase.
- Balanced Reaction Coil.**—A coil employed in a system of distribution by alternating-current transformers for maintaining a constant current in the secondary circuit or circuits despite changes in the load placed therein.
- Balanced Resistance.**—A resistance so placed in a bridge or balance as to be balanced by the remaining resistances in the bridge.
- Balanced System.**—An electric system of distribution or communication which is so adjusted as to be free from mutual inductive disturbances from neighboring systems.
- Balancing.**—Rendering a metallic telephone circuit free from inductive disturbances from other lines.
- Balancing Coil of Armature.**—An auxiliary field-winding in series with an armature, and having its magnetomotive force equal and opposite to that of the armature current, so that their total magnetic effect upon the field is zero, and the field flux remains unchanged at all loads.
- Balancing of Telegraph Line.**—In duplex or quadruplex telegraphy the operation of adjusting the balance between the real and artificial lines, whereby the home signals do not affect the receiving instruments.
- Balancing Relay.**—A differentially wound relay.
- Balancing Resistance for Dynamos.**—A regulating resistance that possesses a sufficient range to balance one dynamo against another with which it is operated in parallel.
- Balancing Thermopile.**—(1) A double thermopile. (2) A differential thermopile.
- Balancing Wire or Conductor.**—A term sometimes employed for the neutral wire or conductor of a three-wire system.
- Balata.**—An insulating material.
- Ball Lightning.**—A name sometimes given to globular lightning.
- Ballistic Curve.**—The curve actually described by a projectile thrown through the air in any other than a vertical direction.
- Ballistic Galvanometer.**—(1) A galvanometer designed to measure the total quantity of electricity in a discharge lasting for a brief interval, as, for example, the current caused by the discharge of a condenser. (2) A galvanometer, in which the movable part is as little damped as possible, suitable for measuring electric charges or discharges, and usually adjusted to have a long period of vibration or slow swing.
- Ballistic Pendulum.**—A pendulum with a heavy bob employed to determine the velocity of a projectile fired into it.
- Balloon Buoy.**—A buoy used in submarine cable work somewhat resembling a balloon in shape.
- Balloon, Electric.**—(1) A balloon or airship provided with electric power so as to be capable of being started or moved against the direction of the wind. (2) An electrically dirigible balloon.
- Balloon Signalling for Military Purposes.**—Transmitting intelligence, as of the movements of an enemy's army, from observations made in balloons by means of telephone circuits directly connected with the balloons.
- Band Arc Lamp.**—An arc lamp in which the feeding of the carbons is effected through the movements of a band of copper, which carries the upper carbon holder and conducts the current into the arc.
- Band or Banded Spectrum.**—The condition assumed by the spectrum of a compressed gas or vapor when sufficiently heated, in which the lines of the ordinary spectrum are broadened into bands.
- Banjo.**—A wooden drum fastened upon a kite-shaped board, employed for tightening a pole-strung telephone or telegraph wire.
- Bank Board.**—A small switchboard containing a bank of lamps used in an alternating-current series-incandescent system of street lighting, and usually supplied with an ammeter and switch for introducing one or more relief lamps.
- Bank of Lamps.**—A group of electric lamps collected together in a common structure, usually for the purpose of obtaining a load.
- Bank of Transformers.**—A group of transformers collected together in a common structure usually either for the purpose of obtaining a load, or for readily varying the pressure.
- Banked Battery.**—A term sometimes applied to a battery from which a number of separate circuits are supplied with current.
- Banking Transformers.**—(1) Grouping

transformers in a common structure either for the purpose of obtaining a load, or for readily varying the pressure. (2) Associating transformers in parallel. (3) Associating transformers in series.

Bar Armature.—An armature whose conductors are formed of bars.

Bar Electro-Magnet.—An electro-magnet, the core of which is in the form of a straight bar or rod.

Bar Windings.—Armature windings composed of copper bars.

Bar-Wound Armature.—An armature in which the conductors have the form of bars.

Barad.—(1) A unit of intensity of pressure. (2) A dyne per square centimetre.

Bare Arc-Light Carbons.—Arc-light carbons or pencils unprovided with an electro-plating of copper or other conducting metal.

Bare Carbons.—Arc-light or battery carbons, unprovided with an electro-plating of copper.

Barker's Wheel.—An early form of reaction water wheel.

Barlow's Wheel.—A wheel or disc of metal, capable of rotation on an axis, that is set into rotation when placed between the poles of magnets and traversed between its centre and circumference by a current of electricity.

Barometer.—An apparatus for measuring the atmospheric pressure.

Barometric Column.—A column, usually of mercury, approximately 30 inches in vertical height, sustained in a barometer or other tube by the atmospheric pressure.

Barometric Gradient.—The drop or fall of atmospheric pressure per unit of distance as measured between two adjacent isobars.

Barrel of Jack.—In telephony a conducting cylinder in a jack for making contact with the sleeve of a plug.

Barrow-Reel.—A reel supported on a barrow for convenience in paying out an overhead conductor during its installation.

Bar Winding of Armature.—A winding consisting of insulated copper bars connected at their extremities.

Base Frame of Generator.—The frame on which a generator is supported.

Basis Metal of Electro-Plating.—The metal on whose surface an electro-plating is to be deposited.

Batch Working.—In telegraphy a method of operating consisting in sending a plurality of messages in one direction over a line, and then a plurality of messages in the opposite direction, as distinguished from up-and-down working.

Bathometer.—An instrument for obtaining deep-sea soundings without the use of a sounding-line.

Battery.—A name frequently used for an electric-battery.

Battery.—(1) To place a storage battery on a storage-battery car. (2) To supply a battery to a station or circuit.

Battery Car.—A storage-battery car.

Battery, Electric.—A general name applied to the combination, as a single source, of a number of separate electric sources.

Battery Gauge.—A form of portable galvanometer suitable for ordinary battery testing work.

Battery Jar.—A jar provided for holding the electrolyte of each of the separate cells of a primary or secondary battery.

Battery Lamp.—An incandescent lamp of such low voltage as to be readily operated by the ordinary voltage of a battery of a few series-connected cells.

Battery Motor.—An electric motor so wound as to be properly operated by the comparatively low electromotive force of an ordinary battery.

Battery of Alternators.—A number of separate alternators so connected as to be capable of acting as a single alternator.

Battery of Generators.—A number of separate generators so connected as to be capable of acting as a single generator.

Battery Pole-Changer.—A form of transmitter employed in duplex telegraphy for readily reversing the direction of the main battery so as to send signals to the line.

Battery Solution.—The exciting liquid or electrolyte of a primary or secondary cell.

Battery Stand.—The insulating or insulated stand provided for holding a primary or secondary battery.

Battery Syringe.—A syringe for either removing the acid or spent liquids from a voltaic battery, or for introducing fresh liquid.

Battery System for Electric Railroads.—A system for the propulsion of street cars by means of storage batteries.

Battery Transformer.—A step-up transformer so wound as to be readily operated

- by a primary battery of a few series-connected cells.
- Battle Circuit.**—A circuit on a warship, connected with the conning tower and provided for use during action.
- Battle Lantern.**—A form of safety lantern for use in action on board a warship.
- Bead Areometer.**—A form of hydrometer suitable for rapidly testing the density of the exciting liquid in a storage cell.
- Bead Chain.**—A chain of metallic beads sometimes employed for the pull in a pendant electric-burner.
- Bead Hydrometer.**—A bead areometer.
- Bead Lightning.**—A form of lightning discharge in which the flashes produce a discontinuous line of light possessing a bead-like appearance.
- Beaded Cable.**—A form of cable employed for high-tension transmission, provided with a sheathing of strung porcelain beads.
- Bec-Carcel.**—The carcel, \curvearrowright French photometric standard.
- Becquerel Radiation.**—An invisible radiation, discovered by Becquerel, emitted by certain salts, especially those of uranium, capable both of penetrating many media opaque to ordinary light, and affecting a photographic plate.
- Becquerel Rays.**—Becquerel radiation.
- Bed-Plate of Dynamo-Electric Machine.**—The base or frame of a dynamo-electric machine.
- Bega.**—A prefix for a billion, one thousand million, or 10^9 .
- Begadyne.**—One billion dynes, or roughly, the earth's gravitational force on a ton of matter.
- Beg-Erg.**—One billion ergs; or, 73.7 foot-pounds, approximately.
- Beg-Ohm.**—One billion ohms, or one thousand megohms.
- Begohm Galvanometer.**—A galvanometer which gives unit deflection through a resistance of one begohm in circuit with one volt.
- Bell Box.**—In telephony a box containing or designed to contain a telephone bell.
- Bell Hanger's Joint.**—A careless form of telegraphic or telephonic joint in which the ends of the wires are merely looped into each other.
- Bell Mouth of Cable Tank.**—A circular aperture provided in the top of a cable tank, through which a cable is led into or taken out of the tank.
- Bell Pull, Electric.**—Any circuit-closing device operated by a pull.
- Bell-Shaped Magnet.**—A modified form of horse-shoe magnet in the form of a split tube, and in which the approached poles are semi circular in shape.
- Bell Switch.**—A switch connected with a telephone alarm-bell for the purpose of throwing it in or out of circuit.
- Belt Circuit.**—A series lighting circuit extending in the form of a wide loop, belt, or circle, as opposed to a circuit formed of two closely associated parallel wires.
- Belt-Driven Generator.**—A generator driven by means of belting, as distinguished from a direct-driven or rope-driven generator.
- Belt-Driving or Coupling.**—Driving or coupling by means of belts.
- Belt, Electric.**—A belt suitably shaped so as to be capable of being worn on the body, consisting either of imaginary or real voltaic or thermo-electric couples, and employed for its alleged therapeutic effects.
- Belt of Current.**—The total current generated by an armature at any moment, assumed as making a single turn around the armature.
- Belt Speed.**—The velocity of translation or linear speed of a belt in the transmission of power.
- Bessel's Functions.**—A series of mathematical functions often connected with problems in electricity and satisfying a certain relation first enunciated by Bessel in connection with an astronomical problem.
- Bias of Relay Tongue.**—A term employed to signify such an adjustment of a polarized relay that on the cessation of a working current the relay tongue shall always rest against the insulated contact, and not against the other contact, or *vice versa*.
- Bichromate Voltaic Cell.**—A zinc-carbon couple employed with a solution of bichromate of potash and sulphuric acid in water.
- Bicro.**—A prefix for one billionth, one thousand millionth, or 10^{-9} .
- Bicro-Ampere.**—The billionth of an ampere.
- Bicro-Farad.**—The billionth of a farad.
- Bicro-Henry.**—The billionth of a henry.
- Bicron.**—A unit of length equal to the billionth of a metre, and indicated by the symbol μ .

- Bicycle Car.**—An electrically propelled car whose weight rests on a single rail, and which is kept in position by a guide rail supported vertically above the main rail.
- Bicycle Electric Lamp.**—An incandescent lamp suitable for use on a bicycle and usually operated by a small voltaic battery.
- Bifilar Control of Galvanometer Needle.**—The control of a galvanometer needle whereby it returns to its position of rest, on the removal of the deviating force, by the operation of a bifilar suspension.
- Bifilar Suspension.**—Suspension by means of parallel vertical wires or fibres as distinguished from suspension by a single wire or fibre.
- Bifilar Winding.**—The method of winding employed in resistance coils to obviate the effects of self-induction, in which the wire, instead of being wound in one continuous length, is doubled on itself before winding.
- Bight of Cable.**—A single loop or bend of cable.
- Bimetallic Accumulator.**—An accumulator or storage cell whose positive and negative plates are formed respectively of two different metals.
- Bimetallic Helix.**—A compound helix of two metals of different expansibilities, such as copper and steel, firmly riveted or soldered together, so that the helix is twisted or moved in one direction by unequal expansion, and in the opposite direction by unequal contraction.
- Bimetallic Thermometer.**—A thermometer whose operation depends on the expansion and contraction of a bimetallic helix.
- Bimetallic Thermostat.**—A form of thermostat employed for opening or closing a circuit by the expansions and contractions of a bimetallic arc-shaped spring.
- Bimetallic Wire.**—A compound telephone or telegraph wire consisting of a steel core and a copper envelope, suitable for long-span overhead-construction.
- Binary Compound.**—A compound formed by the union of two different elements.
- Binding Coils.**—Coils of wire, wound on the outside of the armature coils and at right angles thereto, to prevent the loosening of the armature coils during rotation by centrifugal force.
- Binding Post.**—A metallic binding screw, rigidly fixed to some apparatus or support, and employed for conveniently making firm electric connections.
- Binding Screw.**—A name sometimes applied to a binding post.
- Binding Wire for Telegraph Lines.**—(1) The wire employed for securing a telegraph wire to the insulator which supports it. (2) A tie wire.
- Binnacle Compass.**—A compass on board ship placed in a binnacle for use in steering or directing the vessel.
- Biograph.**—An apparatus for obtaining on a screen, from a rapid succession of suitable pictures, the appearance of the actual movements of natural objects.
- Bioplasm.**—(1) Any form of living matter possessing the power of reproduction. (2) Living protoplasm.
- Bioscope.**—A biograph.
- Bioscopy, Electric.**—The determination of the presence of life or death by the passage of electricity through the nerves or muscles.
- Bipolar.**—Having two poles.
- Bipolar Armature.**—An armature suitable for use in a bipolar field.
- Bipolar Armature-Winding.**—Any armature winding suitable for use in a bipolar field.
- Bipolar Bath.**—An electro-therapeutic bath, the current supplied to which enters at one part of the bath-tub and leaves at another.
- Bipolar Dynamo-Electric Machine.**—A dynamo-electric machine with a bipolar field.
- Bipolar Generator.**—A bipolar dynamo-electric machine.
- Bipolar Magnetic Field.**—A magnetic field formed by two opposite magnetic poles.
- Bird Cage, Electric.**—A bird-cage-shaped wire screen employed by Hertz in his investigations on the propagation of electromagnetic waves for screening the spark micrometer.
- Bird Cage.**—In submarine cable-work, a mechanical distortion of the sheathing in which the wires are locally bulged outwards leaving the serving or core visible or exposed.
- Birmingham Wire Gauge.**—An English wire gauge.
- Bismuth Spiral.**—A flat spiral of bismuth wire employed for the measurement of strong magnetic fields.
- Bi-Telephone.**—A term sometimes applied to a double telephone receiver ar-

ranged so as to permit the ready application of both ears of the listener to the receiving instruments.

Bivalent.—(1) Possessing an atomicity or valency of two. (2) Divalent.

Bitite.—A variety of insulating material.

Black Electro-Metallurgical Deposit.
A dark electro-metallurgical deposit that is thrown down from the metal in a plating bath when too strong a current is employed.

Black Lead.—Plumbago or graphite.

Black Leading Machine for Electro-Types.—A machine for covering the printing surface of the wax impression employed in electro-typing with an electrically conducting surface of black lead.

Black Light.—Non-luminous radiation.

Blake Telephone Transmitter.—A form of carbon telephone transmitter.

Blank Panel.—A panel on a switchboard provided for the support of extra circuit connections or instruments.

Blasting, Electric.—The electric ignition of powder or other explosive material in a blast.

Blavier's Formulæ.—The formulæ employed in the Blavier test.

Blavier's Test.—A test introduced by Blavier, for localizing a single fault in a single telegraph line or conductor, by measuring the resistance at one end of the line, when the other end is successively freed and earthed.

Bleaching, Electric.—A bleaching process in which the bleaching agents are liberated as required by electrolytic decomposition.

Block.—To stop or check by means of a block system.

Block-Facing.—In a system of electric distribution means a section of conductors extending in front of a city block-facing.

Block System for Railroads.—A system for avoiding the collision of moving railroad trains, by dividing the road into a number of separate blocks or sections of a given length, and so maintaining telegraphic communication between towers located at the ends of each of such blocks, as to prevent, by the display of suitable signals, more than one train or engine from being on the same block at the same time.

Block Wire.—The line or wire employed in block systems for railroads connecting each block tower with the next tower on each side of it.

Blooms.—Masses of wrought or cast metal, generally rectangular in shape and approximately six inches square and three or four feet in length, from which wires are obtained by rolling.

Blow.—To melt or fuse a safety fuse.

Blow-Pipe, Electric.—A blow-pipe in which the air-blast is obtained by a convective electric discharge.

Blower, Electric.—An electrically driven blower.

Blowing a Fuse.—The fusion or volatilization of a fuse wire or safety strip by the current passing through it.

Blowing Point of Fuse.—The current strength at which a fuse blows or melts.

Blue Magnetic Pole.—A term sometimes employed for the south-seeking magnetic pole.

Bluestone Gravity Cell.—A voltaic cell consisting of a zinc-copper couple whose elements are immersed respectively in electrolytes of zinc sulphate and copper sulphate.

Board of Trade Unit.—(1) A unit of electric supply, or the energy contained in a current of 1,000 amperes flowing for one hour under a pressure of one volt. (2) A kilowatt-hour.

Boat, Electric.—An electrically propelled boat.

Bobbed.—A word employed to characterize a surface that has been polished by the action of a bob.

Bobbin, Electric.—A coil of insulated wire suitable for the passage of an electric current for any purpose, as, for example, energizing an electro-magnet.

Body-Protector, Electric.—A device for protecting the human body against the accidental passage through it of an electric discharge.

Boiler-Feed, Electric.—A device for electrically opening a boiler-feed apparatus when the water in the boiler falls to a certain predetermined point.

Boiling of Secondary or Storage Cell.
A term sometimes applied to the gassing of a storage cell.

Bole.—A unit of momentum, proposed by the British Association, equal to one gramme-kine.

Bolognian Stone.—A name formerly given to a calcareous substance that becomes phosphorescent on exposure to light.

Bolometer.—(1) An apparatus for electrically measuring small differences of temperature. (2) A fine wire or thin strip

of metal whose resistance is altered by incident radiant energy.

Bolometric Spectrum.—The luminous and non-luminous spectrum obtained by the use of a rock-salt prism, or a diffraction grating, for the measurement of radiation in the bolometric spectrometer.

Bolometric Spectrometer.—A spectrometer designed for the measurement of radiation, luminous or otherwise.

Bolt.—A lightning discharge.

Bombardment, Electric.—Molecular bombardment.

Bombardment Incandescent Lamp, Electric.—An electric lamp in which refractory material is rendered incandescent by molecular bombardment produced by the passage of an electric discharge through a rarefied space.

Bonded Rails.—In any electric system where the rails are used as a part of the circuit, as in a trolley system, rails connected at their joints by suitable bonds for the purpose of bringing them into good electric contact with one another.

Bonding Resistance of Rail.—The resistance offered in a rail circuit at the bonded joints.

Bonsalite.—An insulating substance.

Bony Current.—The electric current resulting from the difference of potential existing between the different parts of a bone in a recently killed animal.

Booster.—A dynamo, inserted in a special feeder or group of feeders in a distribution system, for the purpose of raising the pressure of that feeder or group of feeders, above that of the rest of the system.

Boreal Fluid.—A term formerly applied to the fluid that was supposed to exist around, or to emanate from, the boreal pole of a magnet.

Boring, Electric.—Forming holes in metals or minerals by the heat of the voltaic arc.

Bot.—A contraction sometimes used for Board of Trade unit of electric supply, or the kilowatt-hour.

Boucherize.—To subject to the boucherizing process.

Boucherizing.—A process for preserving wooden telegraph poles, or railroad sleepers, by injecting a solution of copper sulphate into the pores of the wood.

Bougie-Decimale.—(1) The standard French candle. (2) A standard of luminous intensity equal to the 1-20th of that of the Violle molten-platinum standard.

Bougie-Metre.—A unit of illumination

equal to the normal illumination from a bougie-decimale at the distance of one metre, sometimes called a lux.

Bound Charge.—The condition of a charge on a conductor placed near another conductor, but separated from it by a medium through which electrostatic induction can take place.

Bow Gear.—The gear placed at the bow of a cable ship for the ready handling of a cable or the ropes used in cable work.

Box Balance.—A box form of electric bridge.

Box Bridge.—A commercial form of electric bridge or balance in which both the arms of the bridge and the known resistances consist of standardized resistance coils placed in a suitable box.

Box-Sounding Relay.—A relay whose magnet is surrounded by a resonant case of wood, for the purpose of increasing the intensity of the sounds made by the armature of the magnet.

Boxing the Compass.—Naming consecutively all the different points or rhumbs of a compass from any one of them.

Bracket-Arm.—An arm supported by a bracket for carrying a line insulator.

Bracket-Arm Hanger.—A hanger for an overhead trolley line supported on a bracket arm.

Bracket Pole.—In a system of overhead wires, a pole employed for the support of the brackets provided for the suspension of the overhead wires or conductors.

Bracket Suspension-Ear.—A trolley ear supported on a bracket arm, designed for the suspension of an overhead trolley wire.

Brake Arm.—An arm or lever connected with the brake shoe, and by which the brake power is applied.

Brake Disc.—An electro-magnet in the form of a disc, employed in an electric street-car brake.

Brake Handle.—A handle projecting above the dasher of a car for the operation of the hand brake mechanism.

Brake Shoe.—A mass of metal whose outline conforms to the tread of a car wheel, which is pressed against the circumference of the wheel on the operation of the brake mechanism, for the purpose of stopping the car.

Braided Wire.—A wire covered with a braiding of insulating material.

Branch.—(1) In a system of parallel distribution, any conductor from which outlets

- are taken or taps made. (2) One of the divisions of a divided conductor.
- Branches.**—(1) Conductors connected to the submains or supply conductors in a system of incandescent lighting. (2) Wires tapped to mains.
- Branch Block.**—A porcelain block provided with suitable grooves in which the terminals or conductors are placed for connecting a pair of branch wires to the mains.
- Branch Box.**—A box containing a branch block.
- Branch Circuits.**—(1) Additional circuits provided at points of a circuit where the current branches or divides, part of the current flowing through the branch, and the remainder flowing through the original circuit. (2) A shunt circuit.
- Branch Conductor.**—(1) A conductor placed in a branch or shunt circuit. (2) A smaller or sub-conductor tapping a main.
- Branch Coupling Box.**—In a system of street mains a coupling box suitable for connecting a house service connection with the incandescent mains supplying the house.
- Branch Cut-Out.**—A safety fuse or cut-out, inserted between a pair of branch wires and the mains supplying them.
- Branch Fuse.**—A branch cut-out or safety fuse.
- Branch of Multiple Circuit.**—Any of the separate circuits that are connected between the mains in a multiple circuit.
- Branch Point of Circuit.**—Any point of a circuit from which a branch is taken off.
- Branch-Wire Terminal Telephone Switchboard.**—A three-wire multiple switchboard for a telephone in which the jacks for any one subscriber are connected in successive panels in parallel instead of in series.
- Branched Magnetic Circuit.**—A magnetic circuit in which the flux subdivides into a number of separate magnetic circuits.
- Branched Series.**—A term sometimes employed for series-multiple.
- Branching Boards.**—Multiple telephone switchboards connected on the branching or multiple system.
- Branching Telephone System.**—(1) A system of multiple telephone switchboards employing the branching or three-wire switchboard. (2) A system of multiple telephone switchboard in which the various jacks on one line are connected in parallel instead of in series.
- Branding, Electric.**—The process whereby a branding tool is heated to incandescence by an electric current instead of by ordinary means.
- Bread-and-Butter Cable.**—A name given to a form of light submarine cable in which the sheathing consists alternately of yarns and wires.
- Breadth Coefficient of Armature Coil.**—The ratio of the effective electromotive force induced in an armature coil to the effective electromotive force which would be induced if the coil had no breadth; *i. e.*, if all its wire could be compressed into the space occupied by a single turn.
- Breadth of Coil.**—The angular distance to which a coil extends circumferentially around an armature core.
- Break.**—Any lack of conducting continuity in a circuit.
- Break-Down Switch.**—A panel switch employed in small three-wire systems, for connecting the positive and negative bus-bars so as to convert the system into a two-wire system, and thus, in case of a break-down, to permit the system to be supplied with current from a single dynamo.
- Break-Induced Current.**—(1) The current induced in an active circuit by breaking or opening that circuit. (2) The current induced in a secondary circuit on the breaking of the circuit of the primary.
- Break Key.**—A key which opens or breaks the circuit when depressed.
- Break Shock.**—A term sometimes employed in electro-therapeutics for the physiological shock produced on the opening or breaking of an electric circuit.
- Break Signal.**—In telegraphy a name given to the signal which separates the preamble from the text of a message, or the text from the signature.
- Breaking Capacity of Switch.**—The strength of current which can be safely and effectively interrupted by a switch, as distinguished from the carrying capacity of the same.
- Breaking Down of Dielectric.**—Such a weakening of a dielectric subjected to electric pressure as permits disruptive discharges to pass through its substance.
- Breaking Down of Insulation.**—The failure of an insulating material, as evidenced by the disruptive passage of an electric discharge through it.

Breaking In.—(1) An interruption in the sending of a telegraphic despatch by an intermediate operator who endeavors to simultaneously use the line. (2) Introducing a key into a telegraph circuit by opening its switch. (3) Interrupting the continuity of a circuit.

Breaking the Primary.—Opening or breaking the circuit of the primary of an induction coil or transformer.

Breaking Weight of Wire.—The weight required to be hung on the end of a wire in order to break it.

Breast Plate.—The breast support for the microphone transmitter of a central telephone station operator.

Breast Telephone Transmitter.—A telephone transmitter supported for convenience on a plate placed on the breast of the operator.

Breath Figures, Electric.—Faint figures of condensed vapor produced by electrifying a coin or other conducting object, placing it momentarily on the surface of a clean, bright, glass sheet, and then breathing gently on the spot where the coin was placed.

Breeze, Electric.—A brush discharge employed in electro-therapeutics.

Breguet's Manipulator.—A sending instrument employed by Breguet in his system of step-by-step, or dial telegraphy.

"Bridge."—A word sometimes employed for multiple-arc.

Bridge Arms.—The arms of an electric bridge or balance.

Bridge Balance of Telegraph Line.—Such a balance of a duplex telegraph line, obtained by an electric bridge, in which the home relay ceases to respond to the home key.

Bridge Duplex.—The bridge method of duplex telegraphy, as distinguished from the differential method.

Bridge, Electric.—(1) A device whereby an unknown electric resistance is readily measured. (2) A device for measuring an unknown resistance by comparison with two fixed resistances and an adjustable resistance.

Bridge Method of Duplex Telegraphy.—(1) A system whereby two telegraphic messages can be simultaneously transmitted over a single wire in opposite directions, when a bridge balance of the line has been obtained. (2) A system of duplex telegraphy by means of a single-bridge duplex-system.

Bridge of a Fuse.—A small gap at a fuse

in a metallic circuit filled with a semi-conducting compound in which heat is developed by a current.

Bridge System of Quadruplex Telegraphy.—A system of quadruplex telegraphy by means of a bridge duplex system.

Bridges.—Heavy copper wires suitably shaped for connecting a dynamo-electric machine in an incandescent lighting station to the bus-bars.

Bridge-Wire.—The wire in a Wheatstone's Bridge in which the galvanometer is inserted.

Bridge with Secondary Conductors. A form of Wheatstone bridge employing an additional pair of resistances, and suitable for measuring very low resistances.

Bridging Bell.—A polarized electric bell permanently connected across the circuit employed in the bridging-bell system of telephony.

Bridging-Bell Telephone System.—A system of telephone communication in which the call bells are placed in multiple-arc, permanently bridging the two line conductors of metallic circuits, or legged to the ground in grounded circuits, so that, when a call is sent out, every bell in the line rings, the particular station needed being indicated by a suitable code of signals.

Bridging Coils.—In telephony, coils which are connected across a telephone circuit, as distinguished from coils placed in series in the circuit.

Bridging Indicator.—In telephony, an indicator connected in shunt across a circuit instead of in series.

Bridging Relay.—In telephony or telegraphy, a relay which is connected in shunt across a circuit instead of in series.

Bridle Chain.—In submarine cable work, the chain on a buoy which is connected to the buoy rope, and by which the buoy rope may be picked up, when the buoy is released at the slip chain.

Bridle Wires.—(1) Wires connecting the separate line wires with a cable box or tower. (2) Wires for looping a telegraph station into a line or lines.

Bright Deposit.—In the electro-plating of silver a bright surface of deposited metal produced by a special final process in the plating.

Bright Dipping.—Cleansing a metal surface by dipping it in acid liquids for the purpose of ensuring a bright electro-metallurgical coating.

Bright Dipping Liquid.—The liquid employed in bright dipping.

Brilliance of Light.—(1) The brightness of a luminous source. (2) The quantity of light that is emitted normally from unit surface of a luminous source. (3) The intrinsic intensity of a luminous source.

Britannia Joint.—A telegraphic or telephonic joint in which the ends of the wires are laid side-by-side, bound together, and subsequently soldered.

British Association Unit.—A term formerly applied to the British Association unit of resistance or ohm.

Broiler, Electric.—An electrically heated broiler.

Broken Circuit.—(1) An open circuit. (2) A circuit whose electric continuity has been disturbed, and through which the current has, therefore, ceased to pass.

Brother-in-Law.—A bell whose sound is the same as that of the car indicator, concealed by a dishonest conductor for the purpose of avoiding ringing the bell of the car indicator when a fare has been collected.

Brush-and-Spray Discharge.—A streaming form of high-potential discharge possessing the appearance of a spray of silvery white sparks, or of a branch of thin silvery sheets around a powerful brush, obtained by increasing the frequency of the alternations.

Brush Contact-Surface.—(1) That portion of a commutator surface which is in contact with the brushes at any moment of time. (2) The surface area of a brush applied to a contact surface.

Brush Discharge.—The faintly luminous discharge which takes place from a positively charged pointed conductor.

Brush Electrode.—A conducting brush-shaped electrode employed in electrotherapeutic treatment.

Brush-Holder Cable.—A stranded conductor or cable employed in a dynamo or motor for direct connection to the brushes.

Brush Holders for Dynamo-Electric Machine.—Devices for supporting the collecting brushes of a dynamo-electric machine.

Brush Pressure.—(1) The electric pressure at the brushes of a dynamo-electric machine. (2) Mechanical pressure on a brush.

Brush Rocker.—In a dynamo or motor any device for shifting the position of the brushes on the commutator cylinder.

Brush Shifting Device.—A modified form of brush rocker.

Brushes of Dynamo-Electric Machines.—Strips of metal, bundles of wire or wire gauze, slit plates of metal, or plates of carbon, that bear on the commutator cylinder of a dynamo, and carry off the current generated.

B-Side of Quadruplex Table.—That side of a quadruplex table which is worked by means of strengthened currents.

Bucking.—A term employed in the operation of street-railway passenger cars for a sudden stopping of the car as if by a collision, due to opposition between two motors.

Buckled Diaphragm.—A fault in a telephonic transmitter or receiver due to a dent or warping in the diaphragm.

Buckling.—The warping or irregularities produced in the surface of the plates of storage cells by a too rapid discharge.

Buffing.—Preparing surfaces for the reception of electro-plating by subjecting them to the polishing action of a revolving wheel covered with a buff, on the surface of which rouge has been spread.

Bug.—(1) A term employed in quadruplex telegraphy to designate any fault in the operation of the apparatus. (2) Generally, a fault in the operation of any electric apparatus. (3) A particular fault or difficulty in quadruplex telegraphy consisting of an interference between the A and B-sides.

Bug-Trap.—A device employed to overcome the bug in quadruplex telegraphy.

Building-Iron.—A heated iron tool by means of which the mould impressed by a printed page, which it is desired to electro-type, is built up preparatory to its being placed in the plating bath.

Building Knife.—A heated knife-shaped tool employed in removing the wax that has been forced up around the sides of the matrix during the taking of the impression.

Building Process for Electro-Type Metals.—A process for bringing up the blank spaces in the mould of an electro-type by the addition of wax plates melted into place by the building-iron, the high spaces thus built-up becoming depressions in the finished plate.

Building Switch.—A switch provided with an insulating handle for cutting a building in or out of an electric circuit, usually, a series circuit.

Building Tool.—A form of building iron.

“**Building-Up**” of Dynamo.—The action whereby a dynamo-electric machine rapidly reaches its maximum E. M. F. after starting.

“**Built-In**” Underground Conductor.—An underground conductor which, instead of being placed in the duct of a conduit or tube so as to be capable of removal therefrom, at any time, is permanently “built in” or surrounded by the insulating and protective material.

“**Built-Up**” Magnet.—A composite permanent magnet.

Bullet Probe.—A probe containing electrical conductors, so arranged that the contact of the probe with a bullet closes an electric circuit and operates an electric signal.

Bunched Cable.—A cable containing more than a single wire or conductor.

Bunsen Screen.—The screen of a Bunsen or translucent-disc photometer.

Bunsen Voltaic Cell.—A zinc-carbon couple whose elements are immersed respectively in electrolytes of dilute sulphuric and strong nitric acids.

Buoy, Electric.—A buoy on which electrically produced luminous signals are displayed.

Burette.—A graduated glass tube employed for readily measuring the volume of a liquid.

Burglar-Alarm, Electric.—An electric device for automatically announcing the opening of a door, window, closet, drawer or safe, or the passage of a person through a hallway, or on a stairway.

Burglar-Alarm Annunciator, Electric.—An annunciator used in connection with a system of burglar-alarms.

Burglar-Alarm Contacts.—Contacts fitted to windows, doors, tills, safes, floors, etc., so that the movements of the various parts from their natural positions, sound an alarm.

Burglar-Alarm Matting.—A matting provided with a number of invisible contacts connected with an alarm bell, whose circuits are closed by treading on the matting.

Buried Cable or Conductor.—An underground cable or conductor placed directly in the earth, in contra-distinction to one placed in a conduit or subway.

Buried Transformer.—A transformer, provided with a water-tight cover and placed below the surface of the ground.

Burn-Out.—The destruction of an armature, or any part of an electric apparatus,

by the passage of an excessive current due to short-circuit or other cause.

Burned-Out Incandescent Lamp.—An incandescent lamp which through continued use is no longer able to furnish electric light.

Burner, Electric.—A gas-burner that is capable of being electrically lighted.

Burnetize.—To subject to the burnetizing process.

Burnetizing.—A method adopted for the preservation of wooden telegraph poles, by injecting a solution of zinc-chloride into the pores of the wood.

Burning at Commutator of Dynamo.
An arcing at the brushes of a dynamo-electric machine, due either to their imperfect contact or improper position, resulting in the loss of energy to the circuit, and the destruction of the commutator segments, or of the brushes.

Burnishing.—A process by means of which surfaces are prepared for electroplating by subjecting them to the action of burnishing tools.

Burnt Electro-Metallurgical Deposit.
The black deposit of metal which is thrown down when the intensity of the depositing current is too strong.

Bus.—A word generally used instead of omnibus.

Bus-Bar Connectors.—Connectors employed for connecting or joining the ends of bus-bars.

Bus-Bar Stand.—A bus-bar support on a switchboard.

Bus-Bar Voltmeter.—A voltmeter employed in a central station for measuring the pressure between the bus-bars.

Bus-Bars.—Heavy bars of conducting metal connected directly to the poles of one or more dynamo-electric machines, and, therefore, receiving the entire current produced by the machines.

Bus Field-Excitation.—Excitation of the field of a generator by current taken directly from the bus-bars.

Bus-Rods or Wires.—Terms frequently used for bus-bars.

Bushing of Socket.—A sleeve or cylinder of insulating material inserted at the entrance of a lamp socket for the protection of the entering conductors.

Busy-Back.—A jack at a central telephone exchange connected with a battery and vibrator, in such a way that the operator by inserting the plug of an incoming line into this jack can notify a calling operator that the subscriber desired is busy.

Busy Test.—A simple test whereby a telephone operator at a multiple switchboard can readily tell whether any wire or circuit connected with the switchboard is or is not in use at any moment of time.

Butt Joint.—(1) An end-to-end joint. (2) A joint effected in wires by placing the wires end on and subsequently soldering or welding them.

Butt Prop.—A tool sometimes called a "dead man," used in the erection of telegraph poles.

Button Repeater.—A manual telegraphic repeater whereby the proper connections

are made for repeating a message in either direction, by turning a button.

Buzzer, Electric.—(1) A call, not as loud as that of an electric bell, employing a humming sound by the use of a sufficiently rapid automatic contact-breaker. (2) A telephone receiver for morse circuits employing a vibrating contact key.

Buzzing of Bell.—An improper action of an electric bell, whereby it produces a buzzing sound instead of its proper ringing.

By-Pass of Discharge.—A term sometimes employed for alternative path.

C

C.—A contraction for Centigrade.

C.—A contraction for current.

C.—A symbol for capacity. (Partly international usage.)

C.—A symbol for coulomb.

C. E. M. F.—A contraction for counter electromotive force.

C. G. S.—A contraction for centimetre-gramme-second.

c. c.—A contraction for cubic centimetre, the C. G. S. unit of volume.

cm.—An abbreviation for centimetre, the C. G. S. unit of length.

cm².—An abbreviation for square centimetre, the C. G. S. unit of surface.

cm³.—An abbreviation for cubic centimetre, the C. G. S. unit of volume.

C. M. M. F.—A contraction for counter-magnetomotive force.

C. P.—A contraction for candle-power.

C. R.—A contraction for conductor-resistance.

C²R Activity.—(1) The I²R activity. (2) That portion of the electric activity which is expended in heating the conductor, and due to the ohmic resistance offered by the conductor to the passage of the current. (3) The thermal activity of a circuit expressed in watts, and equal to the square of the current strength in amperes multiplied by the resistance in ohms.

C²R Loss.—The loss of energy in a conductor due to the ohmic resistance and the current strength.

C. G. S. Units.—The centimetre-gramme-second units.

Cabinet Seat Contact.—A contact placed in a silence telephone cabinet, underneath a seat, and closed by the weight of a person on the seat.

Cable.—(1) An electric cable. (2) A message transmitted by means of an electric cable.

Cable.—To send a telegraphic despatch by means of a cable.

Cable Alphabet.—The code or telegraphic alphabet employed in cable signalling.

Cable Box.—A box provided for the reception and protection of a cable head.

Cable Buoy.—A buoy generally secured by a mushroom anchor and provided for temporarily holding or securing an end of a cable during its laying or repair.

Cable Casing.—The metallic sheathing of a cable.

Cable Cell.—A voltaic cell formed by an exposed broken end of a submarine copper conductor and the iron sheathing of the cable.

Cable Clearing-House System.—A system whereby every message sent over a submarine cable is returned to the head office and a comparison effected between the original message, as received for transmission, and the final message, as delivered to the addressee.

Cable Clip.—A term sometimes used for cable hanger.

Cable Closing Machine.—A machine for covering a cable with its sheathing.

Cable Code.—(1) A cable alphabet. (2) A cable cipher.

Cable Core.—(1) The insulated conducting wires of an electric cable. (2) The electrically essential portion of a cable as distinguished from its sheath or protection.

Cable Cross-Connecting Board.—In a telephone exchange, where a number of cables enter the building from the outside, a distributing board, placed in a terminal room to facilitate the work that is

constantly going on of making and changing the connections of the subscribers' lines to the switchboard cables.

Cable Currents.—(1) Various currents that exist in a submarine cable and interfere with the testing, consisting of earth currents, electrostatic charge and discharge currents, and polarization currents due to a fault or break. (2) A current flowing through a cable in the absence of any impressed E. M. F. (3) The current which tends to flow in a broken cable from the exposed copper conductor at the fracture to the iron sheathing through the apparatus at the station.

Cable Despatch.—A despatch sent by means of a cable.

Cable Drum.—(1) In cable machinery, a drum on which cable is wound for coiling, shipping, laying, or turning over. (2) A drum or reel on which cable is wound for transport.

Cable, Electric.—A combination of an extended length of a single insulated electric conductor, or of two or more separately insulated electric conductors, covered externally with a metallic sheathing or armor.

Cable Fault.—Any failure in the proper working of a cable due either to a total or partial fracture of the cable, or to a heavy electric leakage.

Cable Float.—A float employed for temporarily relieving the tension on a cable while it is being paid out.

Cablegram.—A telegraph message received by cable.

Cable Grapple.—A heavy pronged iron hook provided for picking up a cable by grappling.

Cable Grip.—(1) The grip provided for holding the end of an underground cable while it is being drawn into a duct. (2) In a cable road the grip by means of which a car is driven by the moving cable.

Cable Ground.—The locality of a cable operation or repair.

Cable Hanger.—A hanger or hook suitably secured to a cable and designed to sustain its weight by intermediately supporting it on an iron or steel wire strung above the cable.

Cable Hanger Tongs.—Tongs provided with long handles for attaching the hangers of an aerial cable to the suspending wire or rope.

Cable Head.—A rectangular board provided with binding posts and fuse wires

for the purpose of receiving the wires of overhead lines where they enter a cable.

Cable House.—A hut provided for securing and protecting the end of a submarine cable when it is landed.

Cable Hut.—A cable house.

Cable Joint.—An insulated electric connection made between the cores of two separate lengths of cable.

Cable Junction-Box.—A junction box for holding and protecting the insulated connections or joints between cables.

Cable Laid-Up-in-Layers.—A cable all of whose conducting wires are in layers.

Cable Laid-Up-in-Reverse-Layers.—A cable the alternate layers of whose conductors are twisted in opposite directions.

Cable Laid-up-in-Twisted-Pairs.—A cable every pair of whose wires is twisted together.

Cable Land Line.—(1) A land line composed of cable. (2) A land line connected to a cable.

Cable Laying.—The process of placing a cable on the sea-bottom.

Cable Lead.—A lead formed of a cable of several stranded conductors, as distinguished from a lead containing a single conductor.

Cable Message.—A cable despatch.

Cable Office.—An office connected with a cable.

Cable Protector.—(1) A device for the safe discharge of the charge induced in the metallic sheathing of a cable, or in the conductors surrounding or adjacent to the cables, consequent on changes in the electromotive force applied to the conducting core of the cable. (2) A fuse device provided for the protection of each of the wires of an aerial cable, placed in the cable head at the junction where an aerial line enters the cable head.

Cable Rack.—A rack placed at the back of a multiple telephone switchboard for supporting the cabled switchboard conductors and providing ready access to the same.

Cable Repairing.—The process of repairing a broken or faulty cable.

Cable Resister.—A form of float or buoy provided for lessening the strain on a cable while paying it out.

Cable Road.—A system of car propulsion in which the cars are drawn by the movement of an underground cable to which the moving cars are attached by a suitable grip.

- Cable Sending-Key.**—A key employed for readily sending the positive and negative current impulses required to transmit the cable alphabet or code.
- Cable Serving.**—A covering of hemp or jute spun around the insulated core of a cable in order to protect it from the pressure of the iron wire armor or sheathing of the cable.
- Cable Ship.**—A ship provided with the apparatus required for laying or repairing submarine cables.
- Cable Signals.**—Signals received over the circuit of a cable.
- Cable Speaking-Set.**—The apparatus used in signalling over a cable.
- Cable Spinning-Jenny.**—A device for readily binding an aerial cable to a supporting wire.
- Cable Splice.**—A connection between the sheathing or armor of two lengths of cable.
- Cable Stopper.**—A flexible grip applied to a cable to keep it from moving or slipping.
- Cable Suspender.**—A device for suspending an aerial cable.
- Cable Switchboard.**—A switchboard to which the cable conductors are connected.
- Cable Tank.**—A strong water-tight tank placed on a cable ship and provided for holding a coiled section of cable that is ready for laying.
- Cable Telegraph.**—A general term including all the apparatus employed in cable telegraphy.
- Cable Telegraphy.**—Telegraphic communication carried on over a submarine cable.
- Cable Terminal.**—A water-tight covering provided at the free end of a telephone cable to prevent injury to the cable's insulation by the moisture of the air.
- Cable Terminal-Pole.**—The terminal pole of an aerial line provided where the ends of an aerial line are connected with an underground cable for the support of the cable head.
- Cable Terminal - Switchboard.**—A board in a cable head where the wires are spread out and connected in proper order to a number of binding posts which in their turn are connected through fuse wires to binding posts receiving the ends of overhead wires.
- Cable Transformer.**—An alternating-current transformer in which the primary and secondary conductors have the form of a cable overlaid by an iron sheath or magnetic circuit.
- Cable Vault.**—A vault provided in a building where cables enter from underground conduits, and where the cables are opened and connected to fusible plugs or safety catches.
- Cable Testing.**—The process or methods of trying or measuring the electric or mechanical capabilities of a cable.
- Cable Well.**—A cable tank.
- Cable Winder.**—A cable spinning-jenny.
- Cable Work.**—Any operation connected with the manufacture, shipping, laying, testing, or repair of cables.
- Cable Worming.**—A central core of hemp or jute around which are wrapped the several separate conductors of any cable that contains more than a single conductor.
- Cabled.**—Transmitted by means of cable telegraphy.
- Cabling.**—Transmitting by means of cable telegraphy.
- Cadmium Standard Cell.**—A standard voltaic cell of very low temperature coefficient of variation in E. M. F., employing a cadmium-zinc couple.
- Cage Lightning-Protector.**—A term sometimes employed for a lightning protector consisting of wires in the form of a cage surrounding the body to be protected.
- Calamine, Electric.**—A crystalline variety of silicate of zinc that possesses pyroelectric properties.
- Calculagraph.**—A machine employed in long-distance telephony for registering the time during which the use of a line by a subscriber continues.
- Cal-Electric Generator.**—A generator whose operation depends on the production of electricity in the secondary coil of a transformer by changes of temperature in its iron core.
- Cal-Electricity.**—Electricity produced by changes of temperature in the iron core of a transformer.
- Calibrate.**—To determine the absolute or relative values of the scale divisions, or of the indications of any electrical instrument, such as a galvanometer, electrometer, voltmeter, wattmeter, or other similar instrument.
- Calibrating.**—Determining or marking off the values or readings of a galvanometer, electrometer, voltmeter, wattmeter, or other similar electrical instrument.
- Call.**—(1) In telephony, the signal or call of

- a subscriber for connection to some other subscriber. (2) In telegraphy, the signal for attention, or the call for response from the distant operator.
- Call-Bell, Electric.**—An electric bell used to call the attention of an operator to the fact that his correspondent wishes to communicate with him.
- Call-Key.**—Any suitable key for sending an electric call.
- Callaud Voltaic Cell.**—A name sometimes given to the blue-stone gravity cell.
- Calling Circuit.**—In the Law system of telephony, a common calling-wire circuit connecting the central exchange through all the subscribers' offices in a given group, and employed for sending calls to the central office.
- Calling Drops.**—In an isolated-station switchboard, drops employed for indicating the particular subscriber calling.
- Calling Plug.**—That plug of a pair of plugs, at a central telephone switchboard, which is inserted in the jack of the subscriber wanted and through which that subscriber is called up.
- Calling Side of Telephone Circuit.**—That side of a telephone circuit over which a call arrives.
- Calling Station.**—Any station that desires to be placed in communication with another station.
- Calling Wire.**—A wire forming the calling circuit in a system of telephony.
- Call Signal.**—In telegraphy, the signal or group of signals indicating the particular station called.
- Call Wire.**—(1) A speaking wire. (2) A wire connecting two telephone exchanges, for the purpose of transmitting instructions, as distinguished from a wire employed for establishing communication between subscribers. (3) A wire employed for calling the attention of a central-station operator by a subscriber, as distinguished from the wires through which he communicates with other subscribers.
- Call-Wire Key.**—A subscriber's key employed to call the operator at a central telephone station.
- Call-Wire Switchboard.**—A switchboard at a telephone station auxiliary to a multiple switchboard in a call-wire system, and employed for suitably dividing up call-wires among the operators, so as to equalize their work.
- Call-Wire System.**—A system of telephony in which special wires are employed to call the operator at the central station.
- Calorescence.**—The transformation of obscure heat rays into luminous rays on impact with certain solid substances.
- Caloric.**—A term formerly applied to the assumed fluid that was believed to be the cause or essence of heat.
- Calorie.**—(1) A heat unit. (2) The quantity of heat required to raise 1 gramme of water 1° centigrade.
- Calorific Intensity.**—The temperature attained in combustion.
- Calorimeter.**—An instrument for measuring the amount of heat contained in, or developed by, a given body.
- Calorimeter, Electric.**—An instrument for measuring the heat developed, in a given time, in any conductor, by an electric current.
- Calorimetric.**—Of or pertaining to the calorimeter.
- Calorimetric Conductivity.**—Specific heat transference, or the conductivity of a substance based on the quantity of heat transferred in a given time, independently of the temperature attained.
- Calorimetric Measurement.**—The measurement of heat energy by means of a calorimeter.
- Calorimetric Photometer.**—A photometer in which the light to be measured is absorbed by the face of a thermo-pile, and its photometric intensity estimated from the strength of the electric current thereby produced.
- Calorimetry.**—The art of measuring heat energy by means of a calorimeter.
- Calorimotor.**—(1) A deflagrator. (2) A word formerly employed for a number of series-connected voltaic cells. (Obsolete.)
- Calory.**—A less preferable orthography sometimes employed for calorie.
- Canalization.**—(1) A network of conductors. (2) A system of electric mains.
- Candle.**—(1) A unit of photometric intensity. (2) The photometric intensity which would be produced by a standard candle burning at the rate of two grains per minute.
- Candle Balance.**—A balance support provided for the standard candle of a photometer, so arranged as continuously to weigh the candle and so determine its rate of consumption while in use.
- Candle, Electric.**—A Jablochhoff candle.
- Candle-Foot.**—A unit of illumination equal to that normally produced by a

standard British candle, at a distance of one foot, and sometimes called a lux.

Candle-Power.—(1) The intensity of light emitted by a luminous body estimated in standard candles. (2) The photometric intensity of one standard candle.

Canopy.—(1) In a multiple telephone exchange, an overhanging frame suitably supported from above, and containing plugs and drops. (2) An ornamental metallic covering employed in incandescent lighting for an electrolier or pendant outlet.

Canopy Switch.—An overhead switch placed at each end of a trolley car for the purpose of permitting the motorman to turn the current on or off the car as desired, when, for example, he wishes to inspect a fuse block or controller without pulling down the trolley pole.

Cant Hook.—A tool employed in the erection of telegraph poles consisting of a pole furnished with a curved pivoted hook employed for turning or rolling a telegraph pole.

Caoutchouc.—(1) A resinous substance possessing high powers of electric insulation, obtained from the milky juice of certain tropical trees. (2) India rubber.

Cap Wire.—An overhead wire carried on the summit of a pole, as distinguished from an overhead wire carried on a cross arm.

Capacity of Dynamo-Electric Machine.—The maximum theoretical activity of a dynamo as expressed by the square of its electromotive force divided by its resistance.

Capacitance.—(1) A term proposed in place of capacity. (2) The reactance of a condenser in an alternating-current circuit.

Capacity Balance of Duplex System.—The balance of capacity in duplex telegraphy as opposed to a balance of resistance.

Capacity Circuit.—A circuit containing capacity but no inductance.

Capacity Current of Cable.—(1) The current in a cable due to its capacity. (2) The charging or discharging current in a cable.

Capacity Load.—The apparent load or current of a high-tension generator due to the capacity of the distributing conductors as distinguished from the load or current usefully distributed.

Capacity of Accumulator.—The available output of a storage battery expressed either in ampere-hours, or in watt-hours.

Capacity of Cable.—(1) The quantity of electricity required to raise a given length of cable to a given potential, divided by the potential. (2) In a multiple cable, the amount of charge at unit potential which any single conductor will take up, the rest of the conductors being grounded. (3) The ability of a conducting wire or cable to permit a certain quantity of electricity to be passed into it before acquiring a certain potential.

Capacity of Cable Tank.—The accommodation of a cable tank expressed either voluminally in cubic feet, or in relation to the number of miles of a given type of cable which can be practically stowed away in it.

Capacity of Condenser.—(1) The quantity of electricity a condenser is capable of holding in coulombs when charged to a pressure of one volt. (2) The ratio between the quantity of electricity in coulombs on one coating of a condenser and the potential difference in volts between the two coatings.

Capacity of Leyden Jar.—The quantity of electricity a Leyden jar will take under unit difference of potential.

Capacity of Line.—The ability of a line to act as a condenser, and, therefore, like it, to possess capacity.

Capacity of Polarization of Voltaic Cell.—The capacity of becoming polarized when subjected to a steady discharge.

Capacity of Secondary or Storage Cell.—The capacity of an accumulator.

Capacity Pressure.—(1) In a condenser connected with a source of alternating currents, a pressure in phase with the condenser current. (2) A pressure due to a capacity. (3) The pressure at the terminals of a condenser.

Capacity Reactance.—(1) The reactance of a condenser due to its capacity. (2) The condensance. (3) The capacitance.

Capacity Resistance.—(1) A term proposed for the resistance which a condenser or other substance possessing electric capacity offers to the passage of an alternating electric current. (2) The impedance of a condenser.

Capillarity.—The elevation or depression of liquids in tubes of small internal diameter.

Capillary.—Of small or hair-like diameter or size.

Capillary Attraction.—The molecular attractions concerned in capillary phenomena.

- Capillary Contact-Key.**—A form of fluid contact-key in which the circuit is closed or broken by means of a wire which is dipped into or removed from the surface of a mass of mercury.
- Capillary Electrometer.**—An electrometer in which difference of potential is measured by the movements of a drop of sulphuric acid in a tube filled with mercury.
- Capsizing Thermometer.**—A thermometer employed in deep sea soundings for cable work, which is caused to record the temperature at the moment the lead commences to ascend from the bottom, by causing the thermometer to be reversed or capsized.
- Car Annunciator.**—An annunciator placed in a car for the purpose of calling a waiter or porter.
- Car Barn.**—A covered shed provided with tracks in which trolley cars are stored when not in use.
- Car Body.**—The wooden framework of a street-railway car which encloses the space provided for the passengers.
- Car-Brake, Electric.**—A car-brake that is operated by the electric current produced by the motor acting as a generator when the current is turned off and the car is rapidly moving.
- Car-Brake Mechanism.**—The mechanism for applying the brake to a car-wheel.
- Car Controller.**—(1) A device placed at each end of the platform of a trolley car, under the control of the motor man for starting, stopping, reversing or changing the velocity of a trolley car. (2) A series-parallel car-controller.
- Car-Heater, Electric.**—An electric heater consisting essentially of suitably supported coils of insulated wire traversed by an electric current.
- Car-Lamp, Electric.**—An incandescent lamp generally provided with an anchored filament, suitable for use in street-railway cars.
- Car-Propulsion, Electric.**—The propulsion of cars by means of electric motors.
- Car Truck.**—The part of a car on which the car body rests.
- Car Wiring.**—The distribution of conductors on an electric street car.
- Carbon.**—An elementary substance which occurs naturally in three distinct allotropic forms: graphite, charcoal and the diamond.
- Carbon Arc.**—A voltaic arc formed between carbon electrodes.
- Carbon Brushes for Electric Motors or Generators.**—Plates of artificial carbon employed as the brushes of dynamos or motors.
- Carbon Button.**—A button-shaped carbon mass whose resistance varies with pressure.
- Carbon Cell.**—(1) A silvered plate of glass provided on its silvered side with a number of zigzag furrows filled with carbon soot, and employed as the receiving instrument in a photophone. (2) A voltaic cell employing carbon as one of its elements.
- Carbon Clutch or Clamp for Arc Lamps.**—A clutch or clamp attached to the lamp rod or the support of the positive or upper carbon of an arc lamp, provided for gripping or holding the carbon.
- Carbon Diaphragm of Telephone.**—A thin sheet of carbon employed as the diaphragm in certain forms of telephone transmitters.
- Carbon Electrodes for Arc Lamps.**—The carbons of an electric arc lamp between which the arc is maintained.
- Carbon Holder.**—A device employed in an arc lamp for supporting the lower or negative carbon.
- Carbon Megohm.**—A resistance of approximately one megohm composed of a thin film or strip of graphite.
- Carbon Motor Brush.**—A carbon brush employed on a motor.
- Carbon Pencils.**—A word sometimes used for the carbons employed in arc lamps.
- Carbon-Point Lightning-Arrester.**—A lightning arrester in which the disruptive discharge occurs between opposed carbon points.
- Carbon Points.**—The carbon rods or pencils employed in arc lamps.
- Carbon Rheostat.**—An adjustable resistance formed of carbon plates or powder whose resistance can be varied by pressure.
- Carbon Telephone Transmitter.**—A telephone transmitter whose operation is dependent on variations in the resistance of a carbon button, or of a mass of loose granulated carbon, on the to-and-fro movements of the diaphragm.
- Carbon Tongs.**—A pair of tongs suitable for gripping arc-light carbons.
- Carbon Transmitter.**—A carbon telephone transmitter.
- Carbons.**—A general term applied to the carbons or negative elements of voltaic cells.

Carbonic Acid Gas.—A gaseous substance formed by the union of one atom of carbon with two atoms of oxygen.

Carboning Lamps.—Placing carbons in electric arc lamps.

Carbonizable.—Capable of being carbonized.

Carbonization.—The act of carbonizing.

Carbonize.—To reduce a carbonizable substance to carbon.

Carbonized Cloth Discs for High Resistance.—Discs of cloth carbonized by heating to an exceedingly high temperature while out of contact with air.

Carbonizer.—Any apparatus suitable for reducing a carbonizable material to carbon.

Carbonizing.—Subjecting a carbonizable substance to the process of carbonization.

Carbonizing Box.—A box prepared for holding the carbon filaments of incandescent lamps during their carbonization.

Carbonizing Frame.—A suitably shaped block of carbon prepared for winding the cotton threads, or other plastic carbonizable material, employed for the filaments of incandescent lamps, before submitting them to the carbonizing process.

Carcass of Dynamo-Electric Machine.
A term sometimes used for the iron framework of a dynamo.

Carcel.—(1) A French photometric standard of light. (2) The light emitted by a lamp of definite dimensions burning 42 grammes of Colza oil in an hour, with a flame 40 millimetres in height.

Carcel Lamp.—An oil lamp employed in France as a photometric standard.

Carcel Standard.—The carcel.

Carcel Standard Gas-Jet.—A lighted gas jet employed for determining the candle-power of gas by measuring the height of a jet of gas, burning under certain conditions, when used in connection with the light of a larger gas-burner burning under similar conditions, for a photometric measurement of electric lights.

Cardan Suspension of Compass Needle.—The gimbal suspension of a compass needle.

Cardew Voltmeter.—A voltmeter whose indications are obtained by the expansion of a long fine wire by the passage through it of the current to be measured.

Carnot's Cycle.—A cycle of steps or operations proposed by Carnot for convenience in studying the transformation of heat into work.

Carriers of Replenisher.—The moving conductors of a replenisher which carry the charges and thus permit an accumulation of such charges.

Carrying Capacity.—The maximum current strength that any conductor can safely transmit.

Carrying Capacity of Safety Fuse.—The maximum current strength which a fuse wire or block can carry without melting.

Carrying Hooks.—A pair of curved hooks pivoted together and provided with handles, for carrying telegraph poles.

Cascade Charging of Leyden Jars or Condensers.—A method of charging Leyden jars or condensers by means of the electricity liberated by induction from one coating when a charge is passing into the other coating.

Cascade Connection.—A term sometimes employed for series connection.

Cascade Connection of Condensers.
A term sometimes employed for a series-connection of condensers.

Case-Hardening, Electric.—Superficially hardening a piece of metal by means of electrically generated heat.

Case Wiring.—A wiring in which the electric conductors are held in place on the walls or ceilings of a room by means of continuous cleats.

Casings.—Grooves or panelled channels for carrying wires in a house.

Cast Rail-Bond.—A method for bonding the successive track rails, in a system of trolley propulsion, by casting molten iron around all except the upper portions of the joint.

Casting, Electric.—A process for casting metals, in which the metals are fused by means of heat of electric origin.

Castor and Pollux Light.—A term formerly used for the St. Elmo's fire.

Catalisis.—An objectionable orthography sometimes employed for catalysis.

Catalysis.—The influence produced on chemical combination or decomposition, by the presence of certain substances which, without undergoing any changes themselves, produce changes in the affinities of other substances by their mere contact or presence.

Catalytic.—Of or pertaining to catalysis.

Cataphoresis.—Electric osmose.

Cataphoretic.—Of or pertaining to cataphoresis.

Cataphoretic Action.—Cataphoretic medication or demedication.

- Cataphoretic Demedication.**—A means whereby material is removed from different parts of the body by means of cataphoresis.
- Cataphoretic Electrode.**—(1) An electrode containing in solution the drug or medicament that is to be introduced into the body by cataphoresis. (2) The anode.
- Cataphoretic Medication.**—The introduction of a drug or medicament into the body by means of cataphoresis.
- Cataphoric.**—Of or pertaining to cataphoresis.
- Catelectrotonus.**—An orthography sometimes employed for cathelectrotonus.
- Catenary.**—A catenary curve.
- Catenary Curve.**—The curve described by the sagging of a wire, under its own weight, when stretched between two points of support.
- Cathelectrotonic.**—Of or pertaining to cathelectrotonus.
- Cathelectrotonic State.**—The condition of increased functional activity of a nerve in the neighborhood of the cathode to whose influence it is subjected.
- Cathelectrotonic Zone.**—A name sometimes given to the peripolar zone.
- Cathelectrotonus.**—In electro-therapeutics the condition of increased functional activity that occurs in a nerve in the neighborhood of the cathode or negative electrode.
- Cathetometer.**—An instrument for the accurate measurement of small heights or distances.
- Cathion.**—The electro-positive ion, atom, or radical, into which the molecule of an electrolyte is decomposed by electrolysis.
- Cathodal.**—Of or pertaining to the cathode.
- Cathode.**—(1) The conductor or plate of an electro-decomposition cell connected with the negative terminal of a battery or other electric source. (2) The terminal of an electric source into which the current flows from the electrolyte of a decomposition cell or voltmeter. (3) The electrode of a bath, tube, body, or device by which the current leaves the same. (4) The negative electrode.
- Cathode Cup.**—(1) A cup-shaped cathode of an X-ray tube. (2) A concave mirror attached to the cathode of an X-ray or other high-vacuum tube.
- Cathode Pictures.**—X-ray or Roentgen-ray pictures.
- Cathode Ray Spectrum.**—A succession of light and dark phosphorescent bands produced on a screen, in an exhausted Crookes tube, by magnetically deflected cathode rays.
- Cathode Rays.**—Radiation emitted from the cathode or negative electrode of a Crookes or X-ray tube.
- Cathodic.**—Of or pertaining to the cathode.
- Cathode Streams.**—Cathode rays.
- Cathodic Current.**—In a polarized voltaic couple immersed in acidulated water, the current produced by the agitation of the plate connected with the cathode.
- Cathodic Electro-Diagnostic Reactions.**—The reactions which occur at the cathode placed on or over any part of a living body.
- Cathodic Rays.**—The cathode rays.
- Cathodic Streamings.**—Cathode rays.
- Cathodogram.**—A Roentgen or X-ray picture.
- Cathodograph.**—A radiograph.
- Cation.**—An orthography sometimes employed for cathion.
- Catoptrics.**—That branch of optics which treats of the reflection of light.
- Cauterization.**—The act of cauterizing or burning with a heated, solid or caustic substance.
- Cauterization, Electric.**—Subjecting to cauterization by means of an electrically heated wire.
- Cauterize.**—To subject to cauterization.
- Cauterizer, Electric.**—A name sometimes given to an electric cautery.
- Cautery Battery.**—A term sometimes employed in electro-therapeutics for a multiple-connected voltaic battery adapted for producing incandescence for cautery effects.
- Cautery Cabinet.**—A cabinet containing a cautery battery, switchboard, cautery knives and other necessaries for electric cauterization.
- Cautery Cell.**—A cell suitable for use in a cautery battery.
- Cautery, Electric.**—The application to the human body of variously shaped platinum wires, heated to incandescence by the electric current, for removing diseased growths, or for stopping hemorrhages.
- Cautery Knife-Electrode.**—A knife-shaped electrode that is rendered incandescent by the passage through it of an electric current.
- Ceiling Block.**—An attachment fastened to the ceiling for suspending flexible

- cords, and connecting them with the supply wires of an incandescent system.
- Ceiling Board.** — An arc-light hanger board.
- Ceiling Bracket.**—(1) A ceiling canopy. (2) A bracket for supporting an insulated wire or wires to a ceiling.
- Ceiling Cut-Out.**—A cut-out placed in a ceiling block.
- Ceiling Fan.**—An electrically driven fan suspended from the ceiling.
- Ceiling Rose.** — An ornamental ceiling plate from which an electric conductor passes.
- Ceiling Rosette.**—An ornamental, rose-shaped ceiling block.
- Cell of Primary or Secondary Battery.** — A jar of a primary or secondary battery containing a single couple and its electrolyte.
- Celluloid Lamp-Filament.** — A lamp filament made by carbonizing celluloid, a modified form of cellulose.
- Celluvert Fibre.**—A variety of insulating material.
- Centi.**— A prefix for the one hundredth part.
- Centi-Ampere.** — The hundredth of an ampere.
- Centi-Ampere Balance.**—An ammeter in the form of a balance, capable of measuring current strengths readily expressed in centi-amperes (*i. e.*, from $\frac{1}{100}$ ampere to 1 ampere).
- Centigrade Thermometer Scale.** — A thermometer scale in which the length of the thermometric tube, between the melting point of ice and the boiling point of water, is divided into one hundred equal parts or degrees.
- Centigramme.** — The hundredth of a gramme; or, 0.1543 grains avoirdupois.
- Centilitre.**—The hundredth of a litre; or, 0.6102 cubic inch.
- Centimetre.**—The hundredth of a metre; or, 0.3937 inch.
- Centimetre-Gramme-Second System.** — A system based on the centimetre as the unit of length, the gramme as the unit of mass, and the second as the unit of time.
- Centimetre-Gramme-Second Units.** — The units of the centimetre-gramme-second system.
- Centipede Cable-Grapnel.** — A grapnel whose projecting prongs give it an appearance somewhat resembling a centipede.
- Central.**—A name given to any central telephone exchange or office.
- Central Galvanization.** — A variety of general galvanization in which the cathode is placed over the epigastrium and the anode moved over the body.
- Central Lighting-Station.**—A station where the generators and distributing apparatus are placed for producing the current which lights the lamps in a given district.
- Central-Station Burglar-Alarm.** — A burglar-alarm whose contacts, situated at the place to be protected, are connected by suitable circuits with alarms placed in a centrally located station.
- Central-Station Lighting.**—The lighting of a number of houses or other buildings from a single centrally located station.
- Central-Station Multiple-Switch-Board.**—A switchboard employed in a central telephone exchange, in which each subscriber's jack appears in more than a single panel.
- Central Telephone Exchange.**—(1) A central telephone office connected with a plurality of subscribers or telephone stations. (2) A central exchange connected with a plurality of local exchanges.
- Central-Telephone-Exchange Multiple-Switchboard.** — Any form of switchboard employed in a central telephone exchange, by means of which numerous subscribers connected therewith can be readily connected to one another.
- Centrally Grounded Wire of Railway Circuit.**—A conductor or wire extending along the roadbed, parallel to the rails of a pair of tracks, connected to the bond wires, and itself grounded at intervals.
- Cement-Lined Conduit.**—A conduit of wood, stone or metal, the surfaces of whose ducts are lined with cement.
- Centre-Pole Trolley Line Construction.**—A form of aerial line construction in which the trolley wires are suspended from poles placed in the middle of the street or road.
- Centre of Distribution.**—In a system of incandescent distribution any point at which the supply current is branched or radially distributed to mains, to sub-mains, or to translating devices.
- Centre of Gravity.**—The centre of weight of a body.
- Centre of Oscillation.**—A point in a body swinging like a pendulum, which is neither accelerated nor retarded, during its oscillations, by the portions of the pen-

- dulum that are situated above or below it.
- Centre of Percussion.**—That point in a body, suspended so as to move as a pendulum, at which a blow perpendicular to the radius would produce no pressure at the axis.
- Centre-Pole Construction.**—In a double-track trolley system, especially on broad streets, a system of pole construction in which poles are placed between the two tracks, provided with bracket arms extending over each track for the support of the trolley wire.
- Centre Railway Line.**—A trolley line of centre-pole construction.
- Centrifugal Force.**—That force which is supposed to urge a rotating body directly away from the centre of rotation.
- Centrifugal Governor.**—A device for maintaining constant the speed of a steam engine or other prime mover, despite certain changes in its load or work.
- Centrifuge.**—(1) An apparatus for separating solids from liquids or liquids of different density from one another by centrifugal forces. (2) A centrifugal separator.
- Centrifuge, Electric.**—A centrifuge driven by an electromagnetic motor.
- Centripetal.**—Seeking the centre.
- Cerebration.**—The action of the brain in producing thought.
- Chafe.**—A weak or worn place in the sheathing of a submarine cable due to attrition.
- Chafing-Dish, Electric.**—An electrically-heated chafing dish.
- Chain Cable-Grapple.**—A grapple whose prongs are attached to the links of a chain.
- Chain Lightning.**—A variety of lightning flash in which the discharge assumes a rippling, chain-like appearance.
- Chain Pull.**—A pendant chain attached to a pendant burner for the movement of the wipe-spark spring and the ratchet in an electrically-lighted gas-burner.
- Chamber of Incandescent Lamp.**—The glass bulb or chamber of an incandescent lamp provided for maintaining a high vacuum, and for the reception of the filament.
- Change-Over Switch.**—A switch provided in a central station for transferring a working circuit from one dynamo to another, or from one battery of dynamos to another.
- Change Ratio of Transformer.**—The ratio of transformation.
- Changing Switch.**—A change-over switch.
- Characteristic Curve.**—(1) A diagram in which a curve is employed to represent the relation of certain varying values. (2) A curve indicating the characteristic properties of a dynamo-electric machine under various phases of operation. (3) A curve indicating the electromotive force of a generator, as a variable dependent on the excitation.
- Characteristic Curve of Dynamo.**—A curve showing the pressure at the terminals of a dynamo at different field excitations.
- Characteristics of Sound.**—(1) The peculiarities that enable different musical sounds to be readily distinguished from one another. (2) The tone or pitch, intensity or loudness, and the quality or timbre of sounds.
- Charge Accumulator.**—A word sometimes given to a Leyden jar or condenser.
- Charge Current on Telegraphic Line.**—The current produced by the initial rush of electricity into a telegraph line on the closing of the circuit.
- Charge, Electric.**—The quantity of electricity that exists on the surface of an insulated electrified conductor.
- Charged Body.**—A body containing an electric charge.
- Charged Cell.**—A cell of a storage battery that has been acted on by a charging current.
- Charging Accumulators or Storage Batteries.**—Sending an electric current into storage batteries or accumulators for the purpose of enabling them to act as electric sources.
- Charging Current.**—The current employed in charging a storage battery or accumulator.
- Chatterton's Compound.**—An insulating compound for cementing together the alternate coatings of gutta-percha employed on a cable conductor, or for filling up the space between the stranded conductors.
- Checking Action.**—A term sometimes employed for a dampening action.
- Checking Instrument.**—An instrument in a cable station for recording sending or out-going signals on a recorder slip.
- Chemical Affinity.**—(1) Atomic attraction. (2) The force that causes atoms to unite and form molecules.
- Chemical Annunciator.**—A term some-

- times employed for electrolytic annunciator.
- Chemical Battery.**—A name sometimes given to a voltaic telegraph battery as distinguished from a dynamo.
- Chemical Change.**—Any change in matter resulting from atomic combination and the consequent formation of new molecules.
- Chemical Effect.**—(1) Any effect occasioned by atomic combination, in which the substances entering into combination lose all those properties and peculiarities by which they are ordinarily recognized. (2) Atomic combination resulting in the formation of new molecules.
- Chemical Equivalent.**—(1) The quotient obtained by dividing the atomic weight of an elementary substance by its atomicity. (2) The ratio between the quantity of an element and the quantity of hydrogen it is capable of replacing. (3) The quantity of an elementary substance that is capable of combining with or replacing one atom of hydrogen.
- Chemical Galvano-Cautery.**—A term sometimes applied to electro-puncture or the application of electrolysis to the treatment of diseased growths.
- Chemical Generator of Electricity.**—A term sometimes employed in place of a voltaic pile or battery.
- Chemical Phosphorescence.**—A variety of phosphorescence in which the emitted light is produced by the actual combustion of a specific chemical substance by the oxygen of the air, as in the phosphorescence of the fire-fly, or the glow-worm.
- Chemical Photometer.**—A photometer in which the intensity of light to be measured is determined by the amount of chemical action produced in a given time.
- Chemical Potential Energy.**—The potential energy possessed by the elementary chemical atoms.
- Chemical Recording Meter.**—A meter which records by means of electrolysis the quantity of electricity supplied in a given time.
- Chemical Separation.**—Chemical decomposition.
- Chemical Telegraph.**—A general term for the apparatus employed in chemical telegraphy.
- Chemical Telegraphy.**—A system of telegraphy, in which the dots and dashes of the Morse alphabet, or other telegraphic code, are recorded on a fillet of moistened paper by the electrolytic action of the current on some chemical substance with which the paper is impregnated.
- Chemical Telephone.**—The name given to a telephone operating on the principles of the electro-motograph.
- Chemical Velocity.**—The ratio of the amount of substance transformed in any chemical process to the time required for its transformation.
- Chemism.**—A word sometimes employed for chemical affinity.
- Chief Operator.**—The senior operator on duty in a telegraph or telephone office.
- Chimes, Electric.**—A chime of bells rung by the attractions and repulsions of electrostatic charges.
- Chimney Bracket.**—A bracket for supporting an overhead wire fastened to a chimney corner.
- Chloride Storage Cell.**—A name given to a storage-cell in which the plates are formed of grids of antimonious lead, cast around pastilles or buttons of fused chloride of lead, which, when properly subjected to the charging current, are converted into spongy metallic lead and lead peroxide, on the negative and positive plates respectively.
- Choke Coil.**—A name sometimes given to a choking coil.
- Choke Magnet.**—A word sometimes used for choking coil.
- Choking Coil.**—A coil of wire so wound on a core of iron as to possess high self-induction when used on alternating-current circuits.
- Choking Effect.**—The effect produced by a choking coil in obstructing or cutting off an alternating current with a smaller loss of power than would its use as a mere ohmic resistance.
- Chord Armature Windings.**—(1) Armature windings partly formed by chords of arcs on the periphery to which they are applied. (2) An armature winding in which the wire is carried from one point on the surface to another along a chord of the included arc.
- Chromosphere.**—An intensely hot gaseous envelope surrounding the central luminous nucleus or photosphere of the sun.
- Chronograph, Electric.**—An electric apparatus for automatically measuring and registering small intervals of time.
- Chronograph Record.**—A record obtained by means of a chronograph.
- Chronometer, Electric.**—An electrically controlled and operated mechanism for indicating and recording time.

- Chronoscope, Electric.**—(1) An apparatus for electrically indicating but not measuring small intervals of time. (2) An electrically operated device by which small intervals of time can be measured.
- Cigar-Lighter, Electric.**—An apparatus for electrically lighting a cigar.
- Cinematograph.**—A biograph.
- Cipher Code.**—A code in which a number of words or phrases are represented by single words, or by arbitrary words or syllables.
- Cipher Message.**—A code message.
- Circle of Reference.**—A circle by reference to which simple-harmonic motion may be studied by comparison with uniform motion around such circle.
- Circuit Breaker.**—Any device for opening or breaking a circuit.
- Circuit Closer.**—Any device for making or closing a circuit.
- Circuit-Closer Bell-Pull.**—A device, suitable for attachment to a mechanical door pull, which makes a contact for the ringing of an electric bell, without preventing the original bell from being operated by the mechanical pull.
- Circuit, Electric.**—The path in which electricity circulates or passes from a given point around or through a conducting path back again to its starting-point.
- Circuit Indicator.**—A rough form of galvanometer employed to indicate the presence and direction of a current in a circuit, and, in some cases, to roughly indicate its strength.
- Circuit Loop-Break.**—A device for introducing a loop into any part of an aerial line circuit.
- Circuit Loop-Break Insulator.**—An insulator employed in a circuit loop-break.
- Circuital.**—(1) Of or pertaining to a circuit. (2) Flowing or passing in a closed circuit.
- Circuital Flux.**—(1) A term sometimes employed for circular flux. (2) The flux surrounding any circuit. (3) Flux completing a closed circuit.
- Circuital Gaussage.**—The gaussage as measured once completely around a closed magnetic circuit.
- Circuital Vector.**—A vector quantity which does not terminate in space but forms a closed curve or endless chain.
- Circuital Voltage.**—The voltage as measured around a closed circuit.
- Circulation.**—The line integral of a vector quantity taken around a circuit.
- Circular Bell.**—A term sometimes applied to a bell so constructed that all of its moving parts are contained in the gong.
- Circular Current.**—A current flowing through a circular path.
- Circular Flux.**—(1) A term sometimes employed for the concentric circular flux which surrounds an active cylindrical wire or conductor. (2) Generally, circuital flux.
- Circular Magnetic Flux.**—Circular flux.
- Circular Magnetism.**—(1) The magnetism of a cylindrical rod of iron or steel one of whose poles extends circumferentially around the rod while the other pole is situated at and around its centre. (2) A circular distribution of magnetic flux.
- Circular Magnetization.**—The magnetization producing circular magnetism.
- Circular Mil.**—(1) A unit of area employed in measuring the cross-section of wires, equal, approximately, to 0.7854 square mils. (2) The area of a circle one mil in diameter.
- Circular Millage.**—The areas of cross-sections of wires or conductors expressed in circular mils.
- Circular Scratch Brush.**—A scratch brush of circular shape, suitable for being set in rapid rotation by a lathe.
- Circular Touch.**—A method of magnetization by touch in which four bars are placed in the form of a rectangle and the magnetizing magnet is placed in contact at any point, drawn around the rectangle a number of times, and removed at the point where its motion began.
- Circular Type of Periodically Alternating E. M. F.**—A periodically alternating E. M. F. having a curve whose values in different parts of a cycle are such that when plotted in a curve they will produce a circular outline.
- Circular Units of Area.**—Various units employed for measuring areas of cross-section by reference to the area of a unit circle, such, for example, as the circular mil.
- Circulating Power.**—A term employed by Hopkinson for the method of taking power out of a machine as a motor and utilizing this power to drive the generator with which it is connected.
- Circumferential Speed.**—The speed of any point on the circumference of a rotating wheel or armature.
- Circumflux.**—A term sometimes employed for the product of armature current and the total number of armature conductors divided by the number of poles.

- Clamp for Arc Lamps.**—(1) A device for gripping the lamp rod of an arc-lamp. (2) The carbon clutch or clamp of an arc-lamp.
- Clamp Splicing-Ear.**—A trolley splicing ear in which the two ends of the wire are placed in the jaws of a clamp and then pressed together and secured by a bolt.
- Clamp Terminals.**—Simple screw-clamps serving as terminals for connecting the ends of flexible cords or other wires.
- Clark Element.**—A name sometimes given to a Clark standard voltaic cell.
- Clark's Compound.**—A bituminous and siliceous compound employed on the outer casing of the sheathing of a submarine cable.
- Clark's Standard Voltaic Cell.**—A form of zinc-mercury couple employed, in connection with electrolytes of mercurous sulphate and zinc sulphate, as a standard cell.
- Clay Electrode.**—A therapeutic electrode of clay shaped so as to fit the part of the body to be treated.
- Clearance.**—The gap space between the surface of a rotating armature and the opposed polar surface of the field magnets of a dynamo or motor.
- Clearance Space.**—The clearance.
- Clearing.**—In telephony, the operation of disconnecting subscribers who have been in connection, and restoring the lines to their normal conditions.
- Clearing-Out Drops.**—(1) Electro-magnetic drop-shutters placed in a telephone exchange in circuit with a pair of communicating subscribers, so that the falling of the shutter when they "ring off" indicates that the conversation is ended. (2) Ring-off drops.
- Clearing-Out Relays.**—Relays provided for operating clearing-out drops.
- Clearing Signal.**—(1) A ring-off signal. (2) A signal in a telephone exchange to indicate that a telephonic conversation has ended.
- Cleat Wiring.**—Placing or establishing electric conductors or wires on walls or ceilings by means of suitably shaped insulating cleats.
- Cleat, Electric.**—A suitably shaped piece of wood, porcelain, hard-rubber or other non-conducting material used for fastening and supporting electric conductors to ceilings and walls.
- Cleavage Electricity.**—Electrification produced by the cleavage of crystalline substances.
- Clepsydra, Electric.**—An instrument for measuring time by the escape of water or other liquid under electric control.
- Click Wire.**—(1) A wire of a multiple telephone switchboard employed for the engaged test, by which a click is heard in the operator's telephone when the subscriber asked for is busy. (2) The busy test wire.
- Clip.**—A slight break in signalling whereby a signal is unduly shortened, that is likely to occur with an imperfect adjustment of duplex or quadruplex telegraphy.
- Clip Switch.**—A switch in which the switch-lever enters the base of a clip.
- Clipping of Telegraphic Signal.**—The curtailing of a telegraph signal due to defective adjustments or to disturbances on the line.
- Clock, Electric.**—A clock the works of which are moved, controlled or regulated, either entirely or partially, by the electric current.
- Clock Meter.**—An electric meter in which clock-work is employed.
- Clock Register.**—A register employed in connection with a clock for recording the time of an occurrence.
- Clockwise Motion.**—A rotary motion whose direction is the same as that of the hands of a clock, viewed from the face.
- Clockwork Feed for Arc Lamps.**—An arc-lamp mechanism in which one or both carbons are fed by trains of wheel work.
- Closed Car-Wheel.**—A car-wheel in which the portion of the wheel between the flange and the axle is formed of an imperforate mass.
- Closed Circuit.**—A completed circuit.
- Closed - Circuit Burglar-Alarm.**—A burglar alarm that is normally on closed circuit, and which operates on the opening of the circuit by the opening of the contacts.
- Closed-Circuit Signalling.**—A system of single-circuit signalling in which the sending batteries are placed at each end of the line and are so connected as to remain always in circuit.
- Closed-Circuit Thermostat.**—A thermostat maintained normally on closed circuit.
- Closed-Circuit Transformer.**—A term sometimes employed for closed iron-circuit transformer.
- Closed-Circuit Voltaic Cell or Battery.**—A voltaic cell or battery that can be left for a considerable time on a closed

- circuit of comparatively small resistance without serious polarization.
- Closed-Circuit Voltmeter.**—A voltmeter intended to be in permanent connection with the pressure it is designed to measure.
- Closed-Circuited.**—Placed in a closed or completed circuit.
- Closed-Circuited Conductor.**—A conductor connected in a closed or completed circuit.
- Closed-Circular Current.**—A current flowing in a circular circuit.
- Closed-Circular Solenoid.**—A circular solenoid closed upon itself so as to form a tore.
- Closed-Coil Armature.**—(1) An armature the coils of which are never on open circuit during rotation. (2) A dynamo armature whose coils are grouped in sections and connected with successive bars of a commutator, so as to be continuously connected together in a closed circuit.
- Closed-Coil Winding.**—Any winding by which the armature coils are connected in closed circuit during the operation of the machine.
- Closed-Conducting Sheath for Lightning Protector.**—A method for lightning protection consisting in forming a wire-sheathing or netting around the object to be protected.
- Closed Iron - Circuit Transformer.**—(1) A transformer, the core of which forms a completed magnetic circuit. (2) An iron-clad transformer.
- Closed Iron - Magnetic Circuit.**—A magnetic circuit all of whose path is completed by iron.
- Closed Loop.**—A single loop of wire or conductor placed on a closed circuit.
- Closed - Loop Parallel - Circuit.**—A variety of parallel circuit in which both the leading and returning conductors form closed loops, between which the translating devices are bridged.
- Closed Magnetic Circuit.**—A magnetic circuit which lies wholly in iron or other substance of high magnetic permeability.
- Closed Magnetic Circuit of Atom.**—A closed magnetic circuit whose flux is supposed to lie entirely within the atom.
- Closed-Magnetic Circuit of Molecule.**—A closed magnetic circuit assumed to lie wholly within the molecule.
- Closed Magnetic Core.**—A magnetic core so shaped as to provide a complete iron path or circuit for the magnetic flux of its field.
- Closet System of Parallel Distribution.**—A system of parallel distribution and house wiring in which the various receptive devices are collected in groups each of which is supplied with a separate and independent supply circuit back to the service; as distinguished from a tree system.
- Closed Trolley Car.**—A trolley car enclosed from the outer air as distinguished from an open or summer car.
- Closure.**—The completion of an electric circuit.
- Clown's Hat Curve.**—A curve of current or electromotive force in which the pressure generated increases or decreases at a rapid rate of change, and whose shape is somewhat similar to the shape of a peaked hat or a clown's hat.
- Club - Footed Electro-Magnet.**—An electro-magnet whose core is in the form of a horse-shoe and is provided with a magnetizing coil on one pole only.
- Cluster Call.**—A globe of metal from which a cluster of incandescent lamps radiate.
- Clutch for Arc Lamps.**—A carbon clutch or clamp for arc lamps.
- Clutching Device.**—(1) Any device employed for clutching or holding the carbons in an arc-lamp. (2) A device for clutching or holding any object subjected to occasional motion.
- Coarse Winding of Field Magnets.**—The series-winding of a compound-wound machine.
- Co-acting.**—Acting simultaneously or together.
- Coating.**—An adherent layer or covering.
- Coating of Condenser.**—A sheet of tin foil placed on one side of a Leyden jar or condenser, directly opposite a similar sheet on the other side, for the purpose of receiving and collecting an electric charge.
- Coatings of Leyden Jar.**—The sheets of tin foil or other conductor placed on opposite sides of a Leyden jar or condenser.
- Code Name.**—In telegraphy, the symbol, word, or group of letters, standing for, or representing the name of some person, association, or thing, according to a pre-arranged code.
- Code or Coded Telegraphy.**—A system of telegraphy employed for sending despatches in which the time required for transmitting is considerably decreased by employing code words instead of the actual words of the message.

Coded Telegraph Messages or Code Messages.—Messages that are sent by the use of prearranged words, any one of which may stand for a group of words, a phrase, or a complete sentence.

Code Time.—In telegraphy, the code signals in the preamble of a message which signify and indicate the time at which the message was received for transmission.

Coefficient of Electro-Magnetic Inertia.—A term sometimes employed in place of the coefficient of inductance or self-inductance of a circuit.

Coefficient of Expansion.—The fractional increase in the length of a bar or rod, when heated from 32 to 33 degrees Fahr., or from 0 to 1 degree Cent.

Coefficient of Hysteresis.—(1) The work expended hysteretically in a cubic-centimetre of iron, or other magnetic substance, in a single cycle of unit magnetic flux density. (2) The coefficient which multiplied by the volume of iron, the frequency of alternation, and the 1-6th power of the maximum flux density gives the hysteretic activity.

Coefficient of Inductance.—(1) A constant quantity such that, when multiplied by the current strength passing through any coil or circuit, will numerically represent the flux linkage with that coil or circuit due to that current. (2) A term sometimes used for coefficient of self-induction. (3) The ratio of the C. E. M. F. of self-induction in a coil or circuit to the time-rate-of-change of the inducing current.

Coefficient of Induction.—A term sometimes used for coefficient of magnetic induction.

Coefficient of Magnetic Induction.—(1) A term sometimes used instead of magnetic permeability. (2) The ratio between the quantity of magnetic flux that passes through any area of normal cross-section of a magnetic circuit and the magnetizing force producing that flux.

Coefficient of Magnetic Leakage.—(1) The ratio of the flux through a leakage path to the flux through an armature. (2) The ratio of the mutual induction in a transformer as reduced by magnetic leakage to the mutual induction in the absence of magnetic leakage.

Coefficient of Magnetization.—A number representing the intensity of magnetization produced in a magnetizable body divided by the magnetizing force, and usually represented by the symbol κ .

Coefficient of Mutual Inductance.—(1) The ratio of the electromotive force induced in a circuit to the rate-of-change of the inducing current in a magnetically associated circuit. (2) The ratio of the total flux-linkage with a circuit proceeding from an associated inducing circuit, to the strength of current flowing in the latter.

Coefficient of Mutual Induction.—The coefficient of mutual inductance.

Coefficient of Potential.—(1) A coefficient which multiplied into the charge of a body gives its potential. (2) The ratio of the potential of an electrified body to its charge, when all neighboring bodies are uncharged.

Coefficient of Reflection.—The percentage value expressing the ratio of the intensity of the reflected ray to the intensity of the incident ray.

Coefficient of Self-Induction.—(1) Self-inductance. (2) The ratio in any circuit of the flux induced by and linked with a current, to the strength of that current. (3) The ratio in any circuit of the E. M. F. of self-induction to the rate-of-change of the current.

Coercive Force.—A name sometimes employed for coercive force.

Coercive Force.—(1) The power of resisting changes in magnetization. (2) In cyclic magnetization the demagnetizing force which must be applied to a magnetic substance in order to completely demagnetize it.

Coherer.—A detector of electro-magnetic waves consisting of conducting particles forming a semi-conducting bridge between two electrodes.

Coil and Plunger for Electro-Magnet.—A movable iron core which is attracted into a hollow coil or solenoid when a current passes through said coil.

Coil, Electric.—(1) A convolution of insulated wire through which an electric current may be passed. (2) A number of turns of wire, or a spool of wire, through which an electric current may be passed.

Coil-Heater, Electric.—A heater whose heat is obtained by the passage of an electric current through a suitably supported coil of wire.

Coil Winding.—Loop or lap winding.

Coil Winding of Alternator.—(1) A form of winding applied to the armature of an alternator in which the wire is made into coils that are laid upon the surface of the armature core. (2) A term sometimes used for loop winding.

- Coiling Space of Cable Tank.**—The space provided in a cable tank for the reception of a cable.
- Coked Core of Incandescent Filament.**
An incandescent lamp filament formed of a core of electrically coked carbon whose surface is covered with a deposit of carbon by the flashing process.
- Coked Filament.**—A carbon filament for an incandescent lamp that has been so subjected to electrical heating in a vacuum as not only to be thoroughly freed from its occluded gases but also to have its carbon changed into a variety of coke.
- Coking, Electric.**—Subjecting carbon to the coking process.
- Coking of Filament.**—Subjecting a filament to the coking process.
- Coking Process for Filament of Incandescent Lamp.**—A process for converting the carbon of an incandescent filament into coke by subjecting it, while in a vacuum, to the prolonged heating action of a powerful electric current.
- Cold Light.**—(1) Luminous radiation unaccompanied by obscure radiation. (2) Radiation confined within the limits of the visible spectrum. (3) The light of a fire-fly or glow-worm.
- Collapsing Drum.**—A visual-signal drum capable of manual distension and collapse.
- Collation.**—The repetition of a message or important parts of the same by an operator at a telegraph station who has received it over the line, to the transmitting operator at the sending station.
- Collecting Ammeter.**—An ammeter in a central station which collects, and, therefore, indicates the total current received from two or more separate generators, and usually employed to indicate the total current output of a station.
- Collecting Brushes of Dynamo-Electric Machine.**—Conducting brushes which bear on the commutator cylinder of a dynamo and carry off the current generated by the E. M. F. in the armature coils. (2) The brushes which bear on the collecting rings of an alternator armature.
- Collecting Combs.**—The collecting points of a frictional electric machine, or of an electrostatic induction machine.
- Collecting Panel.**—A panel in a switchboard which collects all the current supplied by the generators connected to that switchboard.
- Collecting Rings for Alternators.**—Metallic rings connected with the terminals of the armature coils of an alternator on which brushes rest to carry off the alternating currents.
- Collectors, Electric.**—Devices employed for collecting electricity from a moving electric source.
- Collectors of Alternators.**—The collecting rings.
- Collectors of Dynamo-Electric Machine.**—The brushes that rest on the commutator cylinder and carry off the current generated on the rotation of the armature.
- Collectors of Frictional Electric Machine.**—The metallic points that collect the charge from the glass plate or cylinder of a frictional electric machine.
- Colloids.**—One of the two classes into which substances are separated by dialysis.
- Colombin.**—An insulating substance consisting of a mixture of sulphates of barium and calcium placed between the parallel carbons of the Jablochhoff candle.
- Column, Electric.**—A term formerly applied to a voltaic pile.
- Colza Oil.**—The oil employed in the Carcel standard lamp.
- Comazant.**—(1) A term formerly applied to a St. Elmo's fire. (2) A corposant.
- Collector Rings.**—The collecting rings of an alternator.
- Comb Lightning-Arrester.**—A form of lightning-arrester in which the line wires are connected to two metallic plates provided with serrations like the teeth of a comb, and placed near to another ground-connected plate, which may or may not be furnished with similar serrations.
- Comb of Storage Battery.**—The grid of a storage battery.
- Comb Protector.**—A comb lightning-arrester.
- Combination Anchor-Poles.**—(1) An anchor pole intended for the support of both aerial wires and aerial cables. (2) A composite anchor-pole.
- Combination Bracket.**—(1) A bracket for supporting a pair of insulators side by side. (2) A bracket for supporting both a gas lamp and an incandescent lamp.
- Combination Fittings for Chandeliers.**
Fittings that provide for the use of both gas and electricity.
- Combination Gas-Fixtures.**—Combination fittings.
- Combination Lightning-Protector.**—A form of combined film and fuse lightning-protector employed on telephone

- circuits, arranged so as to ground the circuit either under the action of high pressures, or under the action of an unduly strong current.
- Combination Line-Protector.**—A combination lightning-protector.
- Combination Protector.**—A combination lightning-protector.
- Combination Rheostat.**—A form of box rheostat, or resistance box, which contains within its cover several separate series of resistance coils.
- Combination Triphase-Winding.**—A triphase winding combining both the star winding and the triangular winding.
- Combined Fibre and Spring Suspension.**—A suspension of a needle by the combined use of a spiral spring and a single fibre.
- Combined Tangent and Sine Galvanometer.**—A galvanometer furnished with two magnetic needles of different lengths, one a small needle for tangent measurements, and the other a long needle for sine measurements.
- "Come Along."**—A small portable vise capable of ready attachment to an aerial telegraph or telephone cable, and used in connection with a line dynamometer to pull up the wire to its proper tension.
- Commercial Efficiency.**—The useful or available energy produced by any machine or apparatus divided by the total energy it absorbs.
- Commercial Efficiency of Dynamo, or Generator.**—The ratio of the output of a dynamo, or the useful and available electric energy delivered at its terminals, divided by its intake, or the mechanical energy required to drive it.
- Commercial Efficiency of Motor.**—The ratio between the mechanical activity developed at a motor pulley and the electric activity absorbed at its terminals.
- Common Arc of Aurora Glory.**—The inner or common arc of an aurora glory.
- Common Return.**—A return conductor common to several circuits.
- Common Side of Quadruplex System.**—In quadruplex telegraphy, the neutral or No 2. side, as distinguished from the polar or No 1. side.
- Communicator, Electric.**—A term formerly employed for a telegraphic key.
- Commutating Machine.**—A rotary transformer.
- Commutation.**—The act of commuting or causing a number of electromotive forces or currents to take one and the same direction.
- Commutation Fringe.**—A term employed for the induction produced by an edge or fringe of the magnetic flux at the pole tip, under which commutation takes place.
- Commutator.**—(1) Any device for changing in one portion of a circuit the directions of electromotive forces or currents in another portion. (2) A device for changing alternating into continuous currents, or *vice versa*.
- Commutator.**—A name sometimes given to a universal switch or pin switchboard.
- Commutator Bar.**—One of the insulated segments of a commutator.
- Commutator Coils.**—Coils wound around an armature core for the purpose of preventing sparking, connected at one of their ends to the main windings at points between the coil sections, and at the other end to the commutator segments.
- Commutator Motor.**—An alternating-current motor in which the armature is provided with a commutator.
- Commutator of Dynamo-Electric Machine.**—The device employed to cause the electromotive forces generated in an armature, on its rotation in the magnetic field, to take one and the same direction externally.
- Commutator Press Button.**—A press button employed in a system of telephony, at a subscribers' station, for calling the central station by reversing a battery.
- Commutator Segments or Strips.**—The insulated bars of a commutator.
- Commutatorless.**—Devoid of a commutator.
- Commutatorless Continuous-Current Dynamo.**—(1) A dynamo that furnishes continuous currents without the aid of a commutator. (2) The so-called unipolar dynamo.
- Commutated.**—Caused to take one and the same direction.
- Commutated Currents or Electromotive Forces.**—Currents or electromotive forces that have undergone commutation.
- Commutated Magneto-Generator.**—A magneto-generator whose currents are commutated.
- Commutated.**—Commutated.
- Commutating.**—Commuting.
- Commuting.**—Changing direction.
- Commuting Transformer.**—A rotary commutator.

Companion Loops.—A pair of telegraphic loop-circuits, connecting a pair of branch offices with the main office, in which there is a duplex set, so connected therewith, that the instruments at the branch offices are made the virtual duplex instruments of the main station; one branch office sending while the other is receiving.

Comparator.—An apparatus for comparing standards of lengths or gauges.

Compartment Man-Hole of Conduit. A man-hole provided with suitably supported shelves or compartments that protect different cable sections.

Compass.—A mariner's compass.

Compass Card.—A card used in a mariner's compass on which are marked the four cardinal points of the compass; North, South, East and West, and again sub-divided into 32 points called rhumbs, and also frequently divided circumferentially into degrees.

Compass Sights.—Small holes or narrow slits made in opaque plates, affixed to the compass box, for use in taking bearings.

Compensated Alternator.—An alternator employed for sustaining a uniform voltage at some point of its circuit under varying loads, whose field magnets are excited partly by constant currents taken from a separate generator, and partly by currents supplied by the load current in the armature.

Compensated Excitation of Alternator.—The excitation of an alternating-current dynamo whose field is partly separately excited, and partly excited from the main circuit of the machine.

Compensated Galvanometer.—A differential galvanometer for indicating pressure at a distant point of a continuous-current circuit, having one coil in shunt and the other in series with said circuit.

Compensated Meter-Bridge.—A meter-bridge so arranged that its indications are compensated for the effects of temperature.

Compensated Resistance-Coil.—A resistance-coil so arranged as to be compensated for the effect of temperature upon its resistance.

Compensated System of Currents.—In telegraphy with the Wheatstone automatic apparatus, a system of double-current signalling in which both the initial and final currents are weakened before removal by the interposition of a resistance in the battery circuit.

Compensated Voltmeter.—A central-

station voltmeter connected to the bus-bars in such a manner that its indications are automatically corrected for the drop of pressure in some particular feeder or group of feeders, so that its readings correspond to the pressure supplied to the mains.

Compensated Wattmeter.—A wattmeter so wound as to be compensated for the effect of reactance in its shunt circuit.

Compensated Coils.—A term sometimes applied to the series coils placed on a shunt-wound machine.

Compensated Condenser.—A condenser employed in duplex telegraphy to give to the artificial line a static capacity equal to that of the main line.

Compensated Potential-Indicator.—A compensated voltmeter.

Compensating Line.—An artificial line employed in duplex telegraphy.

Compensating Magnet.—A magnet placed over a galvanometer or other needle, for the purpose of varying the direction and intensity of the earth's magnetic force on such needle.

Compensating Pole.—A small bar electro-magnet, or electro-magnetic coil, placed perpendicularly between the pole-pieces of a dynamo to compensate for the cross magnetization of the armature currents.

Compensating Wire.—In a system of differential duplex telegraphy, the artificial line or wire, as distinguished from the real line or wire.

Compensation Photometer.—(1) A photometer in which the illumination of the two parts of the photometer screen is equalized by diminishing the intensity of the pencil of light by polarization. (2) A polarization photometer.

Compensator.—An auto-transformer.

Compensator for Alternating-Current Lamps.—A choking coil or compensator, placed in circuit with the lamps in an alternating-current circuit, for the purpose of automatically regulating the current strength in the lamps.

Compensator System.—A system of alternating-current electric distribution from high-pressure mains to low-pressure translating devices, in which the latter are connected in derived circuits between sections of choking coils connected across the mains.

Complement of Angle.—What an angle lacks to make its value equal to 90°, or a right angle.

Complete Fault.—Any fault which completely interrupts telegraphic or telephon-

- ic communication as distinguished from a partial fault.
- Complete Wave.**—(1) Two successive alternations, or a double alternation of a periodically-alternating quantity. (2) A cycle.
- Completed Circuit.**—(1) A closed circuit. (2) A circuit whose conducting continuity is unbroken.
- Completing a Circuit.**—Closing a circuit.
- Complex Distribution of Lamellar Magnetism.**—A distribution of the magnetism of a finite magnet into an infinite number of complex-magnetic shells.
- Complex-Harmonic Motion.**—Motion resulting from the superposition or coaction of a plurality of simple-harmonic motions.
- Complex-Harmonic Alternating E. M. F.s.**—Electromotive forces resulting from the combination of a fundamental-harmonic electromotive force and its harmonics.
- Complex-Harmonic Currents.**—Currents produced by complex-harmonic electromotive forces.
- Complex-Harmonic Electromotive Forces.**—Complex-harmonic alternating electromotive forces.
- Complex-Magnetic Shell.**—(1) A magnetic shell whose strength varies from one part to another of its surface. (2) A distribution of magnetization equivalent to an association or superposition of a number of separate magnetic shells of arbitrary strength and area.
- Complex Quantities.**—Any quantity made up of two parts, one of which is measured along an axis of reference, and the other in a direction at right angles to such axis, these axes being sometimes described as the real and imaginary axes respectively.
- Component.**—One of the two or more separate forces into which any single force may be resolved; or, conversely, the separate forces which together produce any single resulting force.
- Component Currents.**—The two or more currents into which it may be conceived that a single current may be divided so as to be the equivalent of that single current.
- Component Electromotive Forces.**—The two or more E. M. F.s into which any given E. M. F. may be resolved.
- Component Inductions.**—The two or more inductions into which any given magnetic flux may be resolved so as to be its equivalent.
- Components of Impedance.**—The energy component or effective resistance, and the wattless component or effective reactance.
- Composite Anchor-Pole.**—A combination anchor-pole.
- Composite Balance.**—A balance with two pairs of fixed coils of coarse and fine wire respectively, employed for measuring strong or feeble currents as desired.
- Composite Dynamo.**—A compound-wound dynamo.
- Composite Excitation.**—Any excitation of the field magnets of a dynamo in which more than a single winding is employed, such as a shunt and a series winding.
- Composite Field.**—The field of a compoundly-excited dynamo.
- Composite-Field Dynamo.**—(1) A dynamo whose field has a composite excitation. (2) A dynamo whose field is compound wound.
- Composite Grid.**—A storage-battery grid made of a number of sheets of lead foil covered with graphite, placed between two plates of sheet lead which are held together with lead rivets.
- Composite Horse-Shoe Magnet.**—A compound horse-shoe magnet.
- Composite Kilo-Ampere Balance.**—A balance form of ammeter, provided with coarse and fine windings, so arranged that the instrument will serve as a kilo-ampere meter, as a centi-ampere meter, or, as a voltmeter.
- Composite Wire.**—(1) A wire provided with a steel core and an external copper sheath, possessing sufficient tensile strength to enable it to be used in long spans without excessive sagging. (2) A bimetallic wire.
- Compoundly-Excited Dynamo.**—(1) A compound-wound dynamo. (2) A composite-field dynamo.
- Composition of Forces.**—Finding the direction and intensity of a single force which represents the total effect of two or more forces that are acting simultaneously on a body.
- Compound.**—An asphaltic composition employed in the sheathing of submarine cables.
- Compound Alternator.**—A compound-wound alternator.
- Compound Arc.**—An arc formed of more than two separate electrodes.
- Compound Battery.**—A term formerly employed for a battery of voltaic cells, as

- contradistinguished from a single cell. (Obsolete.)
- Compound Cable.**—A multiple-core cable.
- Compound Circuit.**—A circuit containing more than a single source, or more than a single electro-receptive device, or both. (Not in general use.)
- Compound Condenser.**—(1) A name sometimes given to subdivided condenser. (2) A composite condenser.
- Compound Electro-Magnet.**—A word formerly employed for an electro-magnet consisting of an iron core wound with two or more separate magnetizing circuits. (Not in general use.)
- Compound Magnet.**—A number of single magnets placed parallel, side by side, and with their similar poles adjacent.
- Compound Radical.**—(1) A group of unsaturated atoms. (2) A group of elementary atoms some of whose bonds are interconnected or joined with the bonds of other atoms.
- Compound Receiver.**—A telephone receiver employed by an operator at a central station, and composed of two separate telephone receivers united into one common frame or receptacle with a single ear-piece, for the purpose of affording a separate distinct circuit and diaphragm, independently of the speaking circuit and diaphragm.
- Compound Telegraph-Wire.**—A bimetallic telegraph wire.
- Compound Winding.**—A method of winding dynamos or motors in which both shunt and series coils are placed on the field magnets.
- Compound - Wound.**—(1) Having associated shunt and series windings. (2) Compositely wound.
- Compound-Wound Alternator.**—An alternator whose fields are compound-wound.
- Compound-Wound Continuous-Current Generator.**—A continuous-current generator whose fields are compound-wound, for the purpose of maintaining the pressure constant under all loads.
- Compound-Wound Field.**—A field provided with compound windings.
- Compound-Wound Motor.**—A motor whose field is compound wound, for the purpose of maintaining its speed constant under all loads.
- Compound-Wound Voltmeter.**—(1) A compensated voltmeter. (2) A voltmeter having more than one winding.
- Concealed Wiring.**—Interior wiring placed out of sight, and either built in the plaster of a room or carried through suitable conduits placed therein.
- Concentration of Lines of Force.**—Any increase in the intensity of a magnetic flux.
- Concentration Throw.**—The deflection of a magnetic needle by a current, produced under certain circumstances by a couple formed of plates or iron or other paramagnetic metal, when exposed to chemical action while in a magnetic field.
- Concentric Cable.**—(1) A cable provided with both a leading and return conductor insulated from each other, and forming respectively the central core or conductor, and the enclosing tubular conductor. (2) A cable having concentric conductors.
- Concentric-Carbon Electrodes.**—Concentric-carbon electrodes employed in a modified form of Jablochhoff candle.
- Concentric Conductors.**—Cylindrical coaxial conductors insulated from each other.
- Concentric-Cylindrical Carbons.**—A cylindrical rod of carbon placed inside a hollow cylinder of carbon, but separated from it either by an air space, or by some refractory insulating material, employed in a form of Jablochhoff candle.
- Concentric Mains.**—Mains employing concentric cables.
- Concentric Wiring.**—Wiring by means of concentric cables.
- Condensance.**—Capacity reactance.
- Condenser.**—(1) A device for increasing the capacity of an insulated conductor by bringing it near another earth-connected conductor but separated therefrom by any medium that will permit electrostatic induction to take place through its mass. (2) Any variety of electrostatic accumulator.
- Condenser Capacity.**—The capacity of a condenser.
- Condenser Circuit.**—Any circuit in which a condenser is inserted.
- Condenser Lightning-Arrester.**—A form of lightning arrester whose operation depends on the connection of a condenser with some part of the circuit to be protected.
- Condenser Pressure.**—The difference of potential at the terminals of a condenser.
- Condenser Rheostat.**—A rheostat in the circuit of a condenser in an artificial line of a duplex or quadruplex system.
- Condenser Signalling.**—Any form of

telegraphic or telephonic signalling in which condensers are employed.

Condenser Working.—Condenser signalling.

Condensing Electroscope.—An electroscope provided with a condenser for the purpose of rendering evident feeble charges.

Conduct.—(1) To pass electricity through conducting substances. (2) To carry, or to possess the power of carrying, an electric current.

Conductance.—(1) A word sometimes used in place of conducting power. (2) The reciprocal of resistance. (3) In a continuous-current circuit the ratio of the current strength to the E. M. F. (4) In an alternating-current circuit the quantity whose square added to the square of the susceptance is equal to the square of the admittance.

Conductance, Electric.—Conducting power for electricity.

Conductance Leak.—A leak in a cable or circuit produced by conduction as distinguished from a leak possessing induction.

Conductibility.—(1) Possessing the power of conducting electricity. (2) Conductivity.

Conducting Cord.—A small insulated flexible cable usually consisting of a stranded conductor or conductors.

Conducting Cord Tip.—A blunted or rounded conductor placed at one of the ends of a cord or wire for the purpose of readily inserting it into a binding post or into a plug hole.

Conducting Loop.—A loop of wire or other electric conductor.

Conducting Power.—The ability possessed by a given length and area of normal cross-section of a substance for conducting light, heat, electricity, or magnetism, as compared with that possessed by an equal length and area of normal cross-section of some other substance taken as a standard.

Conducting Power for Electricity.—The ability possessed by a given length and area of normal cross-section of a substance to conduct electricity, as compared with that possessed by an equal length and area of normal cross-section of some other substance taken as a standard, such, for example, as pure copper.

Conducting Power for Heat.—The ability possessed by a substance to transmit heat through its mass.

Conducting Power for Lines of Magnetic Force.—(1) Permeability. (2) Inductivity.

Conduction Current.—The current that passes through a metallic or other conducting substance, as distinguished from one produced in a non-conductor or dielectric.

Conduction, Electric.—(1) The so-called flow or passage of electricity through a metallic or other similar substance. (2) The ability of a substance to determine the direction in which electric energy shall be transmitted through the ether surrounding it. (3) The ability of a substance to determine the direction in which a current of electricity shall pass from one point to another.

Conduction Lightning-Protection.—The protection of any instrument from the passage of a current due to lightning through its coils.

Conduction Lightning-Protector.—A lightning protector by means of which a current is prevented from passing through the coils of a galvanometer, or other needle instrument, and thus injuriously disturb the magnetism of the needle.

Conduction Resistance.—The resistance offered by a conductor to an electric current.

Conductive.—Possessing the power of conducting.

Conductive Discharge.—A discharge effected by leading the charge off through a conductor placed in contact with the charged body, as opposed to a convective or disruptive discharge.

Conductivity, Electric.—(1) The reciprocal of electric resistivity. (2) The conductance of a substance referred to unit dimensions.

Conductivity Resistance.—The resistance offered by a substance to electric conduction, or to the passage of electricity through its mass.

Conductor.—(1) Any substance which will permit the so-called passage of an electric current. (2) A substance which possesses the ability of determining the direction in which electric energy shall pass through the ether in the dielectric surrounding it.

Conductor Resistance.—A term frequently employed for copper resistance.

Conductor System.—A network of interconnected conductors employed for distributing electricity.

Conduit Cables.—A cable conductor or set of conductors laid in a conduit.

Conduit Conductors.—Conductors intended for use in underground circuits, provided with an insulation suitable to maintain the electric integrity of the separate circuits.

Conduit, Electric.—An underground space, either single or provided with a number of separate spaces called ducts, employed for the reception of electric wires or cables.

Conduit Trolley-System.—A single or double-trolley system in which the trolley wire or wires are placed in an underground slotted conduit, the trolley wheel being replaced by a plow or sled pushed or drawn through the slot.

Coned Plunger for Electromagnetic Solenoid.—A cone-shaped core, employed in connection with a solenoid instead of the ordinary cylindrical core, for the purpose of obtaining a comparatively uniform pull through a fairly extended movement of the core.

Conflict, Electric.—A term proposed for the magnetic field surrounding an active conductor.

Congelation.—The act of freezing, or the change of a liquid into a solid on loss of heat.

Conical Conductor.—(1) A cone-shaped conductor, which gradually increases or decreases in diameter, thus assuming the form of a tapering cone, employed to obtain an approximately constant current density through a system of parallel distribution. (2) In practice, a cylindrical conductor that tapers by sections, the diameter being reduced in each succeeding length.

Conjoined E. M. F.'s.—A number of electromotive forces simultaneously acting in one circuit.

Conjugate Coils.—Two coils whose conductors are conjugate to each other.

Conjugate Conductors.—(1) In a conducting net-work, two conductors so related that the introduction of an E. M. F. in one produces no current in the other. (2) Two conductors so placed as regards each other that an interruption of the current in one, produces no induced current in the other.

Conjugate Functions.—The real and imaginary components of a function of a complex variable.

Connect.—To place or bring into electric contact.

Connecting.—Placing or bringing into electric contact.

Connecting Bars.—Metallic bars at a call-wire multiple-switchboard, for connecting the operator's set with the call-wire jacks through a cord.

Connecting In "Bridge."—A phrase sometimes employed for connecting in multiple arc or parallel.

Connecting Jack.—A jack for introducing a loop into a telephone circuit.

Connecting Peg.—A metallic block for bridging an air gap and so making an electric connection.

Connecting Screws.—A term sometimes employed indifferently for connectors or for binding posts.

Connecting Side of Telephone Switchboard.—That side of a telephone switchboard at which connections are made with subscribers wanted, as distinguished from the side at which calls are received.

Connecting Sleeve.—A metallic sleeve employed as a connector for readily joining the ends of two or more wires.

Connecting-Up.—(1) In telegraphy, joining up. (2) The operation of establishing an electric circuit.

Connection.—The act of placing in electric or magnetic contact.

Connection Board of Transformer.—A board usually located in an accessible place in a transformer case, and provided with binding posts for conveniently making or changing the connections of the transformer coils with the external circuits.

Connection for Intensity.—A phrase formerly employed for connection in series. (Nearly obsolete.)

Connection for Quantity.—A phrase formerly employed for connection in multiple. (Nearly obsolete.)

Connection in Cascade.—A term sometimes employed for connection in series.

Connection in Sequence.—A term sometimes used for connection in series.

Connection of Battery for Intensity.—A term formerly employed for the series-connection of the cells in a battery. (Obsolete.)

Connection of Battery for Quantity.—A term formerly employed for a multiple or parallel connection of the cells in a battery. (Obsolete.)

Connector.—A device for readily connecting or joining the ends of two or more conductors.

Conning Tower.—A shell-proof tower from which the commander on a turreted

- war-ship directs its movements when in action.
- Consequent Points.**—The points or places in an anomalous magnet where its consequent poles are situated.
- Consequent Pole.**—(1) A magnet pole formed by two free north or two free south poles placed together. (2) A magnet pole developed at some point of a magnet other than its extremities.
- Consequent Poles of Dynamo.**—(1) Dynamo poles formed by the juxtaposition of two similar magnetic poles. (2) Dynamo poles developed at polar projections unprovided with magnetizing coils.
- Consequent Resistance.**—A term proposed for the apparent resistance of a conductor traversed by alternating currents, as modified by the skin effect, and as distinguished from its ohmic resistance or its inductive resistance.
- Conservation of Energy.**—(1) A term indicative of the fact that energy can never be annihilated, so that if it disappears in one form, it must reappear in some other form. (2) The indestructibility of energy.
- Consonance.**—(1) A phase agreement between two simple-periodic waves or vibrations. (2) The reinforcement of sound waves, or their increase in intensity, by means of vibrating bodies that are not in resonance with, or are tuned to vibrate in unison with, the sounding body. (3) Forced unison.
- Consonance, Electric.**—In an alternating-current circuit the co-phasing of the impressed E. M. F. with the primary current, due to the influence of capacity in an inductively associated secondary circuit.
- Consonant Electric Circuit.**—(1) An alternating-current circuit containing resistance and inductance, and inductively associated with a secondary circuit containing resistance, inductance, and capacity, in such a manner that the secondary inductance and capacity neutralize the inductance of the primary circuit. (2) A primary alternating-current circuit devoid of reactance or choking effect, owing to the presence of a condenser in a secondary circuit, as distinguished from the effect of a condenser inserted in the primary circuit directly.
- Consonator.**—Any body capable of reinforcing sound by consonance.
- Constant.**—Possessing an invariable value.
- Constant Cell.**—Any voltaic cell which, under certain circumstances, is capable of furnishing a constant electromotive force and current.
- Constant Current.**—(1) A direct current, or one that always flows in the same direction. (2) A current whose strength is unvarying.
- Constant-Current Alternating-Current Dynamo.**—An alternator which supplies a constant effective current strength in its circuit.
- Constant-Current Arc-Lamp.**—A series-connected arc-lamp.
- Constant-Current Circuit.**—A circuit whose current strength is maintained constant notwithstanding changes in its resistance.
- Constant-Current Dynamo.**—A constant-current generator.
- Constant-Current Generator.**—A term applied to a generator intended to produce a constant strength of current despite changes in its load.
- Constant-Current Transformation.**—A change or transformation in the strength of a constant current.
- Constant-Current Transformer.**—(1) A transformer which is intended to raise or reduce a current strength in a given constant ratio. (2) A transformer designed to maintain a constant strength of current in its secondary circuit, despite changes of load.
- Constant Inductance.**—(1) The inductance of a circuit immersed in or wholly surrounded by a material of constant magnetic permeability. (2) An inductance which does not vary with the current strength.
- Constant-Potential Alternating-Current Dynamo.**—(1) An alternator which supplies a constant effective pressure at its terminals. (2) A compounded alternator.
- Constant-Potential Arc-Lamp.**—An arc lamp employed on constant-potential or incandescent mains.
- Constant-Potential Circuit.**—(1) A circuit whose potential is maintained approximately constant. (2) A multiple-arc or parallel-connected circuit.
- Constant-Potential Dynamo.**—(1) A dynamo that furnishes an approximately constant difference of potential or electromotive force despite changes in its resistance or load. (2) A shunt or compound-wound dynamo.
- Constant-Potential Generator.**—A constant-potential dynamo.

- Constant-Potential Motor.**—(1) A motor designed for operation by means of a constant-potential current. (2) Generally, a shunt-wound or compound-wound motor.
- Consumer.**—One who receives electric supply.
- Consumer's Terminals.**—In a system of electric distribution the terminals of a house service, the property of the house, and at which the electric supply is delivered by the supply company.
- Consumption Circuit.**—Any circuit in which an electro-receptive device is placed.
- Contact Breaker.**—A device for breaking or opening an electric circuit.
- Contact Electromotive Force.**—Electromotive force produced by the mere contact of dissimilar metals.
- Contact Electricity.**—Electricity produced by contact electromotive forces.
- Contact Force.**—A contact electromotive force.
- Contact Lamp.**—A name sometimes given to a semi-incandescent lamp.
- Contact Resistance.**—Resistance produced at the contact of two or more surfaces.
- Contact Ring of Telephone Plug.**—A plug in a multiple telephone switchboard carrying an insulated metal ring or sleeve establishing a circuit for the busy test.
- Contact Rings of Alternator.**—The collector rings of an alternator.
- Contact Series.**—A series of metals arranged in such an order that each becomes positively electrified by contact with the one that follows it.
- Contact Screw.**—A screw the end of which is provided with a platinum or other contact, employed to close the circuit of any electric device in whose circuit it is placed.
- Contact Theory of Electricity.**—A theory that ascribes the production of electromotive forces, or of electricity, to the contact of dissimilar substances or surfaces.
- Contact Theory of Voltaic Cell.**—The contact theory of electricity applied to the production of electricity in a voltaic cell.
- Contacts.**—(1) Conducting pieces or plates introduced into electric circuits at points where it is desired to open and close the circuit. (2) A variety of fault occasioned in any circuit by the accidental contact of any part of the circuit with a conducting body. (3) A metallic cross or faulty connection between two telegraphic or telephonic circuits.
- Containing Cell.**—(1) A jar provided for holding or containing the solution or electrolyte employed in connection with a primary or secondary voltaic couple. (2) A jar or receptacle for containing any liquid or solution, as in an electro-plating bath.
- Continental Telegraphic-Code.**—A telegraphic-code employed in Europe generally.
- Continuator.**—A constant-current dynamo. (Not in use.)
- Continuity of Circuit.**—The uninterrupted conducting condition of a circuit.
- Continuity-Preserving Transmitter.**—A transmitter employed in duplex telegraphy, so arranged that the line wire may be transferred from the battery to the earth without any break in the continuity of the circuit.
- Continuous-Alternating Transformer.**
(1) A secondary generator for transforming continuous into alternating currents.
(2) A dynamotor, motor-dynamo, or rotary transformer.
- Continuous Current.**—(1) An electric current which flows in one and the same direction. (2) A direct current.
- Continuous-Current Arc.**—A voltaic arc produced by a continuous current, as distinguished from one produced by alternating currents.
- Continuous-Current Armature-Windings.**—Armature windings suitable for use in continuous-current generators.
- Continuous-Current Dynamo-Electric Machine.**—A continuous-current generator.
- Continuous-Current Generator.**—Any generator capable of furnishing continuous currents.
- Continuous-Current Motor.**—A motor operated by continuous or direct currents.
- Continuous-Current Transformer.**—(1) A dynamotor or motor-dynamo. (2) A transformer from one continuous pressure and current to another.
- Continuous E. M. F.'s.**—Electromotive forces whose direction and value remain constant.
- Continuous-Sounding or Ringing Electric-Bell.**—(1) An electric bell, which on completion of its circuit continues sounding until stopped. (2) A trembling bell.
- Continuous Spectrum.**—(1) A luminous spectrum that is devoid of the Fraunhofer

dark lines, or which contains all the physiologically effective luminous frequencies. (2) The spectrum of a sufficiently heated incandescent solid.

Continuous-Surface Commutator.—A dynamo commutator, whose surface contains no breaks in the gaps between contiguous commutator bars; *i. e.*, whose gaps are filled with an insulating material instead of being left with air spaces.

Continuous Trolley Wire.—An unjointed trolley wire.

Continuous Winding.—A term frequently employed for wave winding or undulatory winding of an armature.

Continuous Wire or Conductor.—An unjointed wire or conductor.

Continuously Insulated Cable.—A length of cable extending continuously between two points without any taps.

Contracting Magnetic Whirls.—Magnetic whirls which are decreasing or moving in towards the electro-magnet or circuit producing them.

Contractures.—In electro-therapeutics prolonged muscular spasms or tetanus caused by the passage of electric currents.

Contraplex Telegraph.—A general term embracing the apparatus employed in contraplex telegraphy.

Contraplex Telegraphy.—Duplex telegraphy in which transmissions are simultaneously made from opposite ends of the line.

Controlled Clock.—A clock whose works are controlled or regulated either entirely or partially, by an electric current.

Controller.—(1) The magnet employed in a system of automatic constant-current regulation, whose coils are traversed by the main current, employed automatically to throw a regulator magnet into or out of the main circuit on changes of the current passing. (2) Any electric mechanism for controlling a circuit or system. (3) An electric switching mechanism for controlling the speed of a motor or motors. (4) A street-railway car-controller.

Controller Resistance.—Resistance employed in connection with street-car controllers for starting or stopping the motors, or for varying their speed.

Controller Switch.—(1) The switch operating the switch cylinder of a street-car controller. (2) Any switch employed in connection with a street-car controller.

Controlling Box.—The box holding any controlling rheostat or controller.

Controlling Block, Electric.—In a system of time-telegraphy, the master clock

whose impulses move or regulate the secondary clocks.

Controlling Magnet.—(1) Any magnet which controls some particular action, as, for example, the attraction of a needle in a galvanometer. (2) A name sometimes given to the controller in an automatic system of current regulation.

Controlling Stand.—The support or stand provided for holding the apparatus employed for controlling a motor.

Convection Currents.—Currents produced by the bodily carrying forward of static charges in convection streams.

Convection, Electric.—The air streams which are thrown off from points on the surface of a charged insulated conductor.

Convection of Heat, Electric.—(1) A term employed to express the dissymmetrical distribution of temperature that occurs when an electric current is sent through a metallic wire, the middle of which is maintained at one constant temperature, and the ends at another constant temperature. (2) Distribution of heat which attends the passage of an electric current through an unequally heated conductor.

Convection Streams.—Streams of electrified air, or other gaseous or vaporous particles, given off from sharp points on the surface of highly charged insulated conductors.

Convection Transference.—The transference of electricity by means of convection streams.

Convective Discharge.—The discharge which occurs from the points of a highly charged conductor, through the electrostatic repulsion of similarly charged air particles, which thus carry off minute charges.

Converging Magnetic Flux.—Magnetic flux that converges or radiates from a point or points.

Conversion of Electromotive Force.—Any increase or decrease in the value of an electromotive force produced by means of a transformer.

Convert.—To transform or change an electromotive force or current.

Converted Currents.—Electric currents whose strengths have been increased or decreased by means of a transformer.

Converter.—A name sometimes given to a transformer.

Converter Bracket.—(1) A bracket for holding a pair of insulators and a single light converter and shunt box in an alternating-current series-system of street light-

- ing. (2) A bracket for supporting an alternating-current converter.
- Converter Fuse.**—A safety fuse connected with the circuit or circuits of a converter or transformer, and usually mounted in the transformer case.
- Converting.**—Transforming or changing an electromotive force or current.
- Converting Currents.**—(1) Changing the value of the current strength by means of transformers. (2) Changing a continuous into an alternating current, or *vice versa*.
- Converting Station.**—(1) A transforming station. (2) A station containing transformers.
- Conveyer, Electric.**—An electrically operated or controlled system of transporting material.
- Convolutions of Wire.**—The separate loops or turns in a helix or coil.
- Cooling-Box of Hydro-Electric Machine.**—A box provided in Armstrong's hydro-electric machine for the steam to pass through before leaving the nozzle.
- Cooling Surface.**—The surface from which a hot body can dissipate its heat energy.
- Cooling Surface of Armature.**—That portion of an armature surface from which it can dissipate into the surrounding air, the heat energy produced in it by the passage of the currents generated during its rotation.
- Cooling Tubes.**—Tubes inserted in the frame or casing of an alternating-current transformer for the supply of cold water from an external pump or source.
- Co-Periodic.**—Possessing the same periodicity.
- Co-Periodic E. M. F.'s, Currents or Fluxes.**—Electromotive forces, currents or fluxes, possessing the same periodicity.
- Co-Phasal.**—Possessing the same phase.
- Co-Phasal Alternations.**—Alternations possessing the same phase.
- Co-Phase.**—(1) Coincidence in phase of co-periodic motions. (2) Such a phase relation between two periodic but non-co-periodic quantities as tends to increase the amplitude of the motion.
- Copper Arc.**—An arc formed between copper electrodes.
- Copper Bath.**—An electrolytic bath containing an electrolyzable solution of a copper salt, and a copper plate forming the anode, and placed in an electrolyte near the object to be electroplated, which forms the cathode.
- Copper Battery.**—A battery employed in sending copper currents to line.
- Copper Conductivity Standard.**—(1) According to rules of the British Institution of Electrical Engineers, a metre-gramme wire of standard conductivity, whose resistance is 0.1519 international ohm at 15°C., corresponding to Matthiessen's standard for hard copper. (2) According to a committee of the American Institute of Electrical Engineers, a copper metre-gramme, of Matthiessen standard soft copper conductivity, whose resistance is 0.1501 ohm at 15°C.
- Copper Connector.**—(1) A particular form of connector employed in the gravity voltaic cell for connecting the copper element to the circuit wire or conductor. (2) A special form of coupler for connecting large wires or conductors.
- Copper Current.**—A term sometimes used in telegraphy for a positive current.
- Copper Efficiency.**—The ratio of the electric energy delivered by a copper conducting system, to the energy delivered to that system.
- Copper Fuse-Wire Terminals.**—Copper terminals provided for connection with the terminals of fuse wires or safety catches.
- Copper Heat.**—The heat which appears in a copper conductor due to the passage through it of an electric current.
- Copper-Lead Accumulator.**—An accumulator or storage battery consisting of plates of copper and lead immersed in a solution of copper sulphate.
- Copper Loss.**—The total loss of energy produced by the passage of a current through the copper wire of a dynamo, motor, or conducting system generally.
- Copper Magnetic Circuit.**—That portion of a magnetic circuit which is completed through copper.
- Copper Plating.**—Electro-plating with copper.
- Copper Resistance.**—In submarine telegraphy, conductor resistance.
- Copper Resistivity.**—The specific resistance of copper of Matthiessen soft copper standard referred to the resistance of a cube one centimetre in length of edge, such a cube offering between parallel faces a resistance of 1.594 microhms at 0° C. (2) The resistivity of a copper wire.
- Copper Ribbon.**—A variety of strap copper.
- Copper Shell of Electro-Type.**—The thin electrolytic deposit of copper which, when stiffened by the backing metal and

suitably mounted on a block, forms the electro-type.

Copper Strap.—Copper conductors in the form of straps or flat bars.

Copper Tape.—Rectangular straps or bars of copper employed for armature windings.

Copper Voltmeter.—A voltmeter whose indications are dependent on the electrolysis of a solution of a copper salt.

Copper-Zinc Accumulator.—An accumulator or storage cell consisting of a plate of copper and a plate of zinc immersed in a solution of zinc sulphate.

Coppered Arc-Light Carbons.—Carbons employed in arc-lamps, covered electrolytically with copper.

Coppered Carbons.—Carbons for arc-lamps, or batteries, that are electrolytically coated with copper.

Coppered Plumbago.—Powdered plumbago coated with copper for use in the metallization of objects to be electroplated.

Copying Telegraph.—A fac-simile or automatic telegraph.

Cord Adjuster.—A device for adjusting the length of a pendant cord.

Cord, Electric.—A flexible, insulated electric conductor, generally containing two parallel wires.

Cord Peg.—A cord to which a connecting peg is attached.

Cord-Peg Connection.—Connection in a switchboard by means of a cord peg.

Cord Pendant.—A flexible or stranded conductor employed for a lamp pendant.

Cord Shelf.—A shelf provided for the holding of the cord pegs of a telephone switchboard.

Core Discs.—Stampings or cuttings of sheet iron, employed, when suitably assembled, for the laminated core of a dynamo or motor armature, or other dynamo-electric apparatus.

Core Losses.—The hysteresis and the Foucault or eddy-current losses of the core of a dynamo, motor, or transformer.

Core Losses of Transformer.—(1) The hysteresis and Foucault-current losses in the core of a transformer. (2) The iron losses in a transformer.

Core of Cable.—(1) The insulated wires employed for the transmission of the current through a conducting cable. (2) The electric conductor and insulator as distinguished from the mechanical serving and sheathing of a cable.

Core Pins of Magnet.—Pins in the cores of a magnet for securing their firm mechanical union with the yoke.

Core Ratio of Cable.—The ratio between the diameter of the core of a cable and the mean diameter of the conductor strand.

Core Transformer.—(1) A transformer in which the iron forms the core or central portion on which the wire windings are placed. (2) A transformer possessing a core capable of insertion or removal.

Cored Carbons.—Arc-light carbons provided with a soft centre of carbon.

Cored Electrodes.—Cored arc-light carbons.

Coreless.—Devoid of a core.

Coreless Armature of Dynamo or Motor.—An armature of a dynamo or motor unprovided with the usual core of iron.

Corn-Plaster Fuse.—A strip of fusible metal rolled up with an asbestos tape in the form of a cylinder and employed as a safety catch in a telephone switchboard.

Cornice Bracket.—A form of insulator bracket for use on the under side of cornices.

Corposant.—A name sometimes given by sailors to the St. Elmo's fire.

Coronæ.—(1) Crown-shaped masses of light sometimes seen during the prevalence of auroræ. (2) Auroral coronæ.

Corpuscle.—(1) An ultimate particle in an assumed highly tenuous substance that was formerly believed to be emitted by highly heated bodies. (2) Any of the ultimate particles of the matter into which it has been assumed that the ultimate elementary atoms may be divided.

Correcting Factor of Wattmeter.—The correction which must be applied to the readings of an alternating-current wattmeter when the reactance in its shunt circuit cannot be neglected.

Correcting Relay.—(1) A relay employed in the Delaney system of synchronous-multiplex telegraphy to aid in obtaining synchronism. (2) In a quadruplex system, a relay intermediate between the polarized receiving relay and its sounder, for the purpose of preventing false signals or kicks.

Correlation of Energy.—A term sometimes applied to the different phases under which energy may appear.

Corrugated Reflector.—A reflector formed of silvered corrugated glass.

Cosine.—(1) One of the trigonometrical functions. (2) The ratio of the base to

the hypotenuse of a right-angled triangle in which the hypotenuse is the radius vector, and the angle between the base and hypotenuse the angle whose cosine is considered.

Cosine Law of Illumination.—The intensity of illumination, of a surface illumined by a single-point source, varies as the cosine of the angle of the rays incident upon the surface from that source.

Cosinusoid.—A curve of cosines.

Cotangent.—(1) One of the trigonometrical functions. (2) The reciprocal of the tangent of an angle.

Coulomb.—(1) The practical unit of electric quantity. (2) Such a quantity of electricity as would pass in one second through a circuit conveying one ampere. (3) The quantity of electricity contained in a condenser of one farad capacity, when subjected to the E. M. F. of one volt.

Coulomb Meter.—A meter for measuring in coulombs, the quantity of electricity which passes through any circuit.

Coulomb's Electric Balance.—A torsion balance for measuring the forces of electric or magnetic repulsion.

Coulomb's Torsion Balance.—An apparatus for measuring the force of electric or magnetic repulsion between two similarly charged bodies, or between two similar magnet poles, by opposing to such forces the torsion of a thin wire.

Coulomb-Volt.—A word sometimes employed for the volt-coulomb or joule.

Counter-Clockwise Motion.—A rotary motion whose direction is opposed to that of the hands of a clock, as viewed from the clock face.

Counter Communication Telephone Switch.—A switch arranged in a telephone system in connection with a silence cabinet, whereby a person occupying the cabinet is unable to call up the exchange without the sanction and assistance of an attendant in the office outside the cabinet.

Counter, Electric.—(1) A device for counting and registering such quantities as the number of fares collected, gallons of water pumped, sheets of paper printed, votes polled, revolutions of an engine per second, etc. (2) Any counting device operated or controlled by electricity.

Counter Electro-Dynamic Force.—The electro-magnetic force which is set up in a dynamo armature opposing the impressed driving force.

Counter-Electromotive Force.—(1) An opposed or reverse electromotive force which tends to set up a current in the opposite direction to that actually produced by a source. (2) In an electric motor, an electromotive force produced by the rotation of the armature and opposed to that produced by the driving current.

Counter-Electromotive Force Cell.—(1) An electrolytic cell inserted in the charging circuit of a storage battery to reduce the charging current strength, usually composed of opposed plates or grids of antimonious lead from the surfaces of which gases are disengaged by electrolysis. (2) Additional cells, generally without active material, employed with a storage battery which has to be charged at a pressure above the normal pressure, and inserted between the dynamo and the mains to maintain their pressure normal.

Counter-Electromotive Force Lightning-Arrester.—(1) A lightning-arrester in which the passage of a discharge through the instruments to be protected is opposed by a counter electromotive force generated by induction on the passage of the lightning discharge. (2.) A choking-coil lightning-arrester.

Counter-Electromotive Force of Arc.—An electromotive force produced during the formation of a carbon voltaic arc opposed to that which maintains the arc.

Counter-Electromotive Force of Convective Discharge.—Resistance to the passage of an electric discharge through a high vacuum, somewhat of the nature of a counter electromotive force.

Counter-Electromotive Force of Electrolysis.—A counter electromotive force produced by electrolysis in the plating bath of an electrolytic cell.

Counter-Electromotive Force of Induction.—The counter electromotive force of self or mutual induction.

Counter-Electromotive Force of Mutual Induction.—(1) Counter-electromotive force produced by mutual induction between neighboring circuits. (2) Counter-electromotive force in the primary circuit of a transformer produced by the mutual induction from the current in the secondary circuit.

Counter-Electromotive Force of Polarization.—Electromotive force developed in a voltaic cell or plating bath by polarization, and opposed to that which produces the current of the cell.

Counter-Electromotive Force of Self-Induction.—The counter-electromotive

force produced in the primary circuit of an induction coil by the action thereon of an alternating electromotive force.

Counter-Electromotive Force of Self-Induction of the Primary.—The counter-electromotive force produced in the primary circuit of a transformer by the action of induction of the primary current on itself, as distinguished from that produced by mutual induction from the secondary current.

Counter-Electromotive Force of Self-Induction of the Secondary.—The counter-electromotive force produced in the secondary by periodic variations in the effective electromotive force in the secondary circuit.

Counter-Electromotive Force of Storage Battery.—The electromotive force in a storage battery which opposes the electromotive force employed in charging.

Counter-Electromotive Force of Voltaic Cell.—The counter-electromotive force in a voltaic cell due to its polarization.

Counter Inductive Effect.—An opposal of current or charge by means of an electromotive force produced by induction.

Counter Pressure.—A term sometimes used for counter-electromotive force.

Couple.—(1) In mechanics, two equal and parallel, but oppositely directed forces, not acting in the same line, and tending to produce rotation. (2) The two elements in a voltaic cell or thermo-electric cell.

Coupled Cells.—A number of separate cells so connected or coupled as to form a battery or single electric source.

Coupling Box for Electric Tubes.—A box provided for the ready connection of the conductors in the separate lengths of underground electric tubes.

Coupling Clamp for Underground Conductors.—An electric coupling between two lengths of underground conductors.

Coupling Joint for Underground Tubing.—A joint for the separate conductors in an underground tubing, consisting generally of a flexible conductor and connectors for ready attachment to the ends of the conductor.

Coupling of Voltaic Cells or Other Electric Sources.—Connecting a number of separate voltaic cells, or other separate electric sources, so as to enable them to act as a battery or single electric source.

Coupling Transformer.—A transformer which employs polyphasal coupling of magnetic circuits.

Cradle Dynamometer.—A dynamometer in which the dynamo to be tested is supported in a cradle, and the mechanical energy it receives or transmits is measured by the torque developed by the cradle about its axis.

Cradle Suspension of Street-Car Motor.—A method of supporting a street-car motor on its truck upon a spring cradle.

Crater in Positive Carbon.—A depression in the end of the positive carbon of an arc-lamp, which occurs after the arc has been maintained for some little time.

“Creep” of Belt.—A term sometimes used for the slip of a belt.

Creepage.—The residual elastic torsion of a suspension fibre.

Creeping, Electric.—A term sometimes applied to the creeping of a current.

Creeping in Voltaic Cell.—The formation by efflorescence of salts on the sides of the porous cup of the voltaic cell, on the binding posts, or on the walls of the vessel containing the electrolyte.

Creeping of Belt.—(1) An action of a driving belt due to its retractility, whereby the driving pulley travels somewhat faster than the driven pulley. (2) Belt slip.

Creeping of Current.—(1) A term sometimes employed for a change in the direction of the path of a current from a direct line between the points of connection with the source. (2) Electrification or polarization currents in an electrolyte. (3) The extension of a glow or streamer discharge over the surface of a dielectric.

Creosoting.—A process employed for the preservation of wood, such, for example, as telegraph poles, by injecting creosote into the pores of the wood.

Crevasse.—A narrow gap or slit effected, or imagined, in a magnet or magnetized substance, for the purpose of determining the magnetic forces on a small needle.

Crith.—A proposed unit of mass, or the weight of one litre or cubic decimetre of hydrogen at 0° Centigrade, and 760 millimetres barometric pressure.

Critical Angle.—The angle of incidence at which a ray of light falling upon the surface of a body ceases to be reflected and is wholly absorbed or internally reflected and refracted.

Critical Current.—The current strength at which a certain critical result is reached.

Critical-Current of Dynamo.—That value of the current of a dynamo at which

its characteristic curve begins to depart from a nearly straight line.

Critical-Current of Magnetization.—

The current strength at which a small increase in the magnetizing current produces a great increase in the magnetization of an iron core.

Critical-Distance of Lateral Discharge through an Alternative Path.—

The distance at which a discharge will take place through an air space of given dimensions, in preference to passing through a metallic circuit of comparatively small ohmic resistance.

Critical Pressure of a Gas or Vapor.—

(1) The lowest pressure at which a substance in the liquid state cannot be partially vaporized by increase of temperature, but changes wholly into a gas. (2) The lowest pressure at which a gaseous substance when cooled is condensed to a liquid in the presence of its vapor. (3) The pressure above which no amount of chilling will liquefy a gaseous substance.

Critical-Speed of Compound-Wound Dynamo.—

The speed at which both the series and shunt coils of a dynamo give the same difference of potential when the full load is on the machine, as the shunt coil would have if used alone on open-circuit. (2) The speed at which a dynamo commences to build up its excitation.

Critical Temperature of a Gas or Vapor.—

(1) The temperature of a vapor at a given pressure above which no pressure, however great, can convert the vapor into liquid. (2) The temperature above which a vapor is essentially a permanent gas.

Critical Temperature of a Substance.—

(1) The temperature above which no pressure applied to the substance in the gaseous form will effect liquefaction. (2) The temperature below which a gaseous substance is a vapor, and as such capable of liquefaction by pressure.

Critical Volume of a Gas or Vapor.—

The volume of a substance at the critical temperature and pressure.

Crookes' Dark-Space.—A dark space surrounding the negative electrode in a rarified space through which electric discharges are passing.

Crookes' Effect.—The effect produced in high-vacuum tubes due to the characteristic motions possessed by heated or electrified molecules when in the ultragaseous or radiant state.

Crookes' Electric Radiometer.—A radiometer in which the repulsions of the

molecules of the residual atmosphere take place from electrified instead of from heated surfaces.

Crookes' Layer.—The dark space or layer enveloping the cathode of an excited Crookes' tube.

Crookes' Radiometer.—An apparatus for demonstrating the action of radiant matter in producing motion, from the effects of the reaction of a stream of molecules thrown off from a number of easily moved, unequally heated surfaces.

Crookes' Tubes.—(1) Glass tubes containing high vacua, provided with platinum leading-in wires terminating in suitably shaped metallic surfaces, employed in demonstrating the peculiarities of the radiant or ultragaseous condition of matter. (2) A name frequently given to X-ray tubes.

Cross.—(1) A connection or contact between two telegraph circuits. (2) A contact between two conductors or circuits which should be insulated from each other.

Cross-Ampere Turns.—(1) Ampere turns on a dynamo armature possessing a cross-magnetizing tendency to distort the magnetic field. (2) Ampere turns which tend to produce a cross magnetization, at right-angles to that produced by the field-magnets.

Cross Arm.—(1) A horizontal beam attached to a pole for the support of the insulators of telegraph, electric light, or other electric wires. (2) A telegraphic arm.

Cross-Arm Bolts.—Bolts employed for attaching the cross-arms to a pole.

Cross-Arm Brace.—Galvanized iron braces whose ends are respectively connected to the pole and the cross-arm for the purpose of stiffening them.

Cross Bonding.—In an electric railway the bonding between the ground feeder and the track for the purpose of ensuring a good conducting return circuit.

Cross-Connected Dynamo.—A dynamo the ends of whose armature coils are connected to corresponding segments all around the commutator.

Cross-Connecting Board.—In a system of telegraphic or telephonic communication, a board to which the line terminals are run, before entering the switchboard, so as readily to place any line in connection with any desired section of the switchboard.

Cross-Connecting Conductors.—(1) The conductors on a cross-connecting board which serve to connect the sections of a

- switch-board with the wires leading to a cable. (2) The conductors which connect corresponding commutator segments in a cross-connected armature.
- Cross-Connecting Telephone Switch-board.**—A telephone distributing board.
- Cross-Connecting Trough.**—A trough dividing a telephone test board from a distributing board, formed for holding the joints in the cross-connections between them.
- Cross-Connection of Armature Windings.**—Armature windings in which the wires are interconnected at the corresponding segments of the commutator.
- Cross-Connection of Commutator.**—The interconnection of the armature coils to corresponding commutator segments.
- Cross Current.**—Current passing between the armatures of alternating current generators, or motors, operated in parallel, and due to differences in the phase or magnitude of the E. M. Fs. in the machines.
- Cross Fire.**—(1) A term employed in telephony or telegraphy for an escape or leakage of current from one line to another, due to defective insulation. (2) Cross talk.
- Cross, Electric.**—(1) A connection, generally metallic, accidentally established between two conducting lines. (2) A defect in a telegraph, telephone, or other circuit, caused by two wires coming into contact by crossing each other.
- Cross Induction.**—(1) An induction produced by the armature current whose magnetization is at right-angles to that produced by the field. (2) Cross magnetization.
- Cross-Induction of Dynamo Armature.**—Cross magnetization produced by a dynamo armature.
- Cross Magnetization.**—A magnetization set up by the currents circulating in the armature turns, which is at right-angles to the magnetization set up by the field flux.
- Cross-Over Block.**—A device to permit the safe crossing of one wire over another in moulding or cleat wiring.
- Cross System.**—A system of running overhead wires for the purpose of preventing mutual inductive disturbances, which consists in crossing or transposing the position of wires on the pole arms at suitable intervals, as distinguished from the twist system.
- Cross-Talk.**—(1) Cross-fire conversation over one telephone circuit which is heard in neighboring telephone circuit. (2) Interference between neighboring telephone circuits.
- Cross-Wire-Suspension for Arc Lamp.** Suspension of an arc-lamp by means of a pulley and cord, attached to a block and tackle suspended from a suitably supported cross wire.
- Crossing Cleat.**—A cleat so arranged as to permit the crossing of one pair of wires under or over another pair without contact with each other.
- Crossing Frog.**—A frog sometimes employed in place of a trolley cross-over.
- Crossing Wires.**—(1) A device employed in telegraphic circuits whereby a faulty conductor is cut out of the line circuit, by crossing it over to a neighboring less-used line. (2) In telegraphy, interchanging sections of wire between two way stations, so as to remove a fault from a circuit or to rearrange a circuit passing through the stations.
- Crow-Foot Zinc.**—A crow-foot-shaped zinc employed in the gravity voltaic cell.
- Crown Telephone Receiver.**—A telephone receiver in which a number of permanent steel magnets are arranged in the form of a crown, all the poles of the same name centring at the soft-iron pole-piece carrying the coil, and the opposite coils being joined to the rim of the diaphragm.
- Crucible, Electric.**—(1) A crucible suitable for electro-metallurgical operations. (2) A crucible in which the heat of a voltaic arc, or of electric incandescence, is employed, to perform difficult fusions, to effect the reduction of metals from their ores, or to form alloys.
- Crystal.**—A solid body bounded by symmetrically disposed plane faces.
- Crystalline Electro-Metallurgical Deposit.**—A non-adherent, non-coherent film of electrolytically deposited metal.
- Crystallization.**—Solidification from solution or fusion in definite forms.
- Crystallization by Electrolytical Decomposition.**—Crystalline deposition of various metals by the passage, under certain conditions, of an electric current through solutions of their salts.
- Crystallize.**—To separate from a liquid or vapor in the form of a crystalline solid.
- Crystalloid.**—Those portions of a mixed substance subjected to dialysis, that are capable of crystallization.
- Cryptoscope.**—(1) An apparatus consisting of a fluorescent screen placed at one end of a light-tight pasteboard tube, and

- viewed at the other end through an eyepiece. (2) A fluoroscope.
- Cryptoscopic Screen.**—(1) The screen employed in cryptoscopy. (2) A fluorescent screen.
- Cryptoscopy.**—The art of examining the body by means of a cryptoscope.
- Cube Knot.**—A unit of volume sometimes employed in calculations of insulation resistance of submarine cables.
- Cubic Energy.**—A term sometimes employed for voluminal energy.
- Cup Brush.**—A brush suitably shaped for polishing the interior surface of a cup or other similar surface of an object that is to be electroplated.
- Cupric Electrolysis.**—In electro-therapeutic treatment, electrolysis performed with copper electrodes whereby a salt of copper is carried into the tissues under the anode by cataphoric action.
- Curb Key.**—A telegraphic key employed in curb signalling.
- Curb Sender.**—An automatic transmitter employed in submarine telegraphy, which is operated by a punched paper strip and which sends curbed signals into the cable.
- Curb Signalling.**—In cable telegraphy, a system for reducing the effects of retardation and increasing the speed of signalling, by following each signalling current with a definite sequence of reversed currents or earthings.
- Curbed Signals.**—Signals sent by means of a curb key.
- Curbing.**—Employing curb signalling.
- Curl.**—(1) The vector part of the nabla of a vector point-function. (2) The line integral of a vector once around any closed loop, and equal to the surface integral of a related vector passing through the loop. (3) The rotation or spin of a vector point-function. (4) A vector which indicates by its direction the plane, and by its length the magnitude, of the maximum vector rate-of-change of a vector point-function in the neighborhood of a given point.
- Current Accumulator.**—Any apparatus in which the strength of an electric current is increased by the motion past it of a conductor, the currents produced in which tend to strengthen and increase the current which causes the induction.
- Current Balance.**—A general name given to a variety of ampere balance which gives readings in various decimals or multiples of amperes, and which determines the strength of current passing, through its action on a movable ring or coil placed between two fixed rings or coils.
- Current Calorimeter.**—An electric calorimeter.
- Current Commuter.**—(1) Any device that causes alternating currents to flow in one and the same direction. (2) A commutator.
- Current-Conveying Helix.**—An active helix.
- Current Density.**—(1) The current strength which passes in any part of a circuit, divided by the area of cross-section of that part of the circuit. (2) The ratio of the current strength through any surface of section of active conductor to the area of that surface, assumed perpendicular to the current.
- Current Distribution.**—The spreading or ramification of electric currents through a conducting mass or network.
- Current Direction-Indicator.**—An instrument for insertion in an arc or other circuit to indicate whether the proper direction of current is maintained.
- Current Diverter for Electric Railways.**—A term sometimes given to the rheostat employed in starting and regulating a street-car motor.
- Current Efficiency of Storage Battery.**—The ratio between the total useful electric quantity delivered by a charged storage battery to the working circuit, to the total electric quantity employed in charging the battery.
- Current, Electric.**—(1) The quantity of electricity per-second which passes through any conductor or circuit, when the flow is uniform. (2) The rate at which a quantity of electricity flows or passes through a circuit. (3) The ratio, expressed in terms of electric quantity per-second, existing between the electromotive force causing a current and the resistance which opposes it.
- Current Equalizer for Storage Battery.**—A device for controlling the strength of the charging or discharging circuit of a storage battery.
- Current Filaments.**—A term sometimes employed in place of current streamlets.
- Current Governor.**—(1) A current regulator. (2) Any device, whether automatic or non-automatic, for maintaining constant the current strength in any circuit.
- Current Induction.**—A term sometimes used for voltaic induction.
- Current Meter.**—(1) Any form of current galvanometer. (2) An indicating ammeter or recording ampere-hour meter.

- Current Recording-Meter.**—A recording ammeter.
- Current Retarder.**—A term sometimes employed for rheostat.
- Current Reverser.**—(1) A switch or other apparatus designed to reverse the direction of a current. (2) A current changer.
- Current Rush.**—The impulsive rush of current that occurs when a transformer is first switched on, or connected with, an alternating-current circuit.
- Current Sheet.**—The area of active conducting surface carrying a current considered as though the current existed as a material sheet.
- Current Spiral.**—A conducting helix or spiral provided for the passage of a current.
- Current Streamlets.**—A conception of a series of parallel current streams or current filaments flowing through a solid conductor.
- Current Strength.**—(1) In a direct-current circuit the quotient of the total electromotive force divided by the total resistance. (2) The time-rate-of-flow in a circuit expressed in amperes, or coulombs per second. (3) In an alternating current the quotient of the total electromotive force divided by the impedance.
- Current System of Induction Telegraphy.**—A system of induction telegraphy on railroads, depending on current induction between a fixed circuit along the roadway, and a parallel circuit on the moving train.
- Current Teaser, Electric.**—A coil of thin wire placed on the field magnets of a dynamo-electric machine in addition to the series coils wound thereon, and connected as a shunt across the main circuit.
- Current Transformation.**—(1) The act of changing the strength of a current by changes effected in its electromotive force. (2) The act of changing a direct into an alternating current, or the reverse, or a uniphase-alternating current into a multiphase-alternating current.
- Current Transformer.**—A device for changing in one circuit the strength of current which flows in another.
- Current Turns.**—(1) The product of the number of turns in a coil by the current flowing through them. (2) A word sometimes used for ampere-turns.
- Current Wave.**—(1) The progressive electro-magnetic disturbance in the ether surrounding a conducting wire forming part of a circuit. (2) The progressive disturbance of electric flow traversing a conducting circuit, under the influence of a variation in its impressed electromotive force.
- Current Weigher.**—(1) A current balance. (2) An ammeter in which the electro-magnetic force of the current is compared with the earth's gravitational force on a mass.
- Currents of Motion.**—A term sometimes employed in electro-therapeutics for the electric currents that are asserted to traverse healthy muscle or nerve tissue, during the sudden contraction or relaxation of such muscle and nerve.
- Currents of Rest.**—A term sometimes employed in electro-therapeutics for the electric currents that are asserted to traverse healthy muscle or nerve tissue while the muscles are passive.
- Curve Guy-Poles.**—Anchor poles or pull-offs, employed in an overhead-trolley system, placed at a curve or turn-out, to which are attached the wire guys employed to preserve the proper tension for the conductor at these points.
- Curve of Sines.**—(1) A curve representing at continuous successive positions the successive values of the sines of a progressively varying angle. (2) A sinusoid. (3) When drawn to rectangular co-ordinates, a curve successively rising above and falling below the axis of abscissas corresponding to the sines of angles measured along said axis.
- Curve of Cross-Over System.**—In a system of transposition for overhead wires, in order to avoid the effects of induction, the short bend of wire which effects the transposition at a pole cross-arm.
- Cushioning Chamber.**—In a dead-beat mirror galvanometer, a chamber before or behind a suspended mirror, for the purpose of dampening the motions of the latter.
- Cut-In.**—To introduce an electro-receptive device into the circuit of a source by completing or closing the circuit through it.
- Cut-In.**—(1) A term sometimes employed for filament cut-out. (2) An automatic guard cut-out.
- Cut-Off.**—Any device for cutting a battery or other electric source from a circuit, or from part of a circuit.
- Cut-Out.**—To remove an electro-receptive device or loop from the circuit of an electric source.
- Cut-Out.**—(1) A device for removing an electro-receptive device or loop from the

- circuit of an electric source. (2) A safety fuse.
- Cut-Out Board.**—A board supporting a number of fuse cut-outs.
- Cut-Out Block.**—A block containing a fuse wire or safety catch.
- Cut-Out Box.**—A box containing a cut-out.
- Cut-Out Cabinet.**—Any enclosed space provided in a building for the reception of cut-outs or fuses.
- Cut-Out Switch.**—A short-circuiting switch by means of which an arc-light is cut out from its feeding circuit.
- Cutting and Holding Grapple.**—In submarine telegraphy, a grapple which, after engaging a cable on the sea bottom, automatically grips the cable, and cuts it beyond the grip.
- Cutting Lines of Magnetic Force.**—Passing a conductor through lines of magnetic force or flux, or passing magnetic lines of force or flux through a conductor, so as to cut or intersect such lines or such flux.
- Cycle.**—(1) A succession of events which periodically recur, reckoning from any stage of the disturbance to the moment at which that stage next occurs. (2) A complete recurrence of any periodic change.
- Cycle of Alternations.**—The cycle of a periodically-alternating electromotive force, current or flux.
- Cycle of Magnetization.**—A single complete passage of any magnetic substance through the successive stages of a periodically-recurring magnetic change.
- Cyclic.**—Of or pertaining to a cycle.
- Cyclic Magnetization.**—Magnetization produced in a magnetic substance when subjected to periodic cyclic changes in the magnetizing force.
- Cyclic Magnetic Variations.**—Secular magnetic variations occurring during great cycles of time.
- Cyclic Motion.**—Any motion which recurs in a cycle.
- Cyclic Stability.**—(1) In an alternating-current circuit the condition of uniform periodic motion in alternating quantities, such as pressure and current, attained after a definite number of cycles from the starting of the motion; as distinguished from the variable state of motion when the circuit is first closed. (2) The permanent state in an alternating-current circuit.
- Cyclometer.**—An instrument for recording the number of turns completed by a wheel, shaft, drum, or other rotating device, or for indicating the distance traversed by its periphery.
- Cyclothesis.**—The existence of independent cycles in a diagram.
- Cyclotrope.**—A word proposed for transformer or converter. (Not in use.)
- Cylindrical Armature.**—A term sometimes applied to a drum armature.
- Cylindrical Carbon Electrodes.**—Carbon cylinders employed for the electrodes of arc lamps or for battery plates.
- Cylindrical Core.**—(1) A cylindrical-shaped mass of iron employed for the core of a solenoid or helix. (2) A cylindrical-shaped mass of soft carbon employed in cored electrodes.
- Cylindrical Electro-Magnet.**—An electro-magnet whose core consists of a hollow cylinder provided with a slot extending parallel to its axis.
- Cylindrical Magnet.**—A cylindrically shaped magnet.
- Cylindrical Ring-Armature.**—A ring armature whose core has the shape of a long cylinder.
- Cylindrical Vibrator.**—A weight in the form of a cylinder supported by a suspension for the purpose of measuring its torsional rigidity.
- Cymogene.**—An extremely volatile liquid hydrocarbon given off from crude coal-oil during the early stages of its distillation.
- Cystoscopy, Electric.**—The examination of the human bladder by electric illumination.

D

- d.—A symbol for diameter.
- D. B. Switch.**—A contraction for double-break switch.
- D. C.**—A contraction for direct current.
- D. E. M. F.**—A contraction for direct-electromotive force.
- “D.” Operator.**—A term employed in mathematics for the operator which effects the total differentiation of a function with respect to time.
- D. P. Cut-Out.**—A contraction for double-pole cut-out.
- D. P. Switch.**—A contraction for double-pole switch.

D. Q.—In submarine telegraphy, a signal serving to separate the address from the text of the message.

Daily Variation of Magnetic Needle. The diurnal variation of the magnetic needle.

Damped Galvanometer.—A galvanometer whose movable part—*i. e.*, whose needle or coil—when moved, comes to rest as quickly as possible.

Damped Magnetic Needle.—A magnetic needle so placed as to come quickly to rest after it has been set in motion.

Damped Vibrations.—(1) Vibrations that occur under circumstances in which the vibratory or swinging motions can be at once brought to rest, instead of repeatedly swinging to-and-fro, on the removal of the force causing the vibration. (2) Vibrations of successively diminishing amplitude.

Dampening Factor.—The property of an oscillatory alternating-current circuit of diminishing the amplitude of its oscillations owing to the influence of electric resistance or of radiation.

Damper.—(1) A metallic cylinder so arranged as to partially or completely surround the iron core of an induction coil for the purpose of varying the intensity of the currents produced in the secondary. (2) A dash-pot, or similar apparatus, provided for preventing the too sudden movements of a lever or other part of a moving device. (3) Any device employed for damping a magnetic needle.

Damping.—(1) The act of stopping a sudden vibratory motion without waiting for it to cease after repeated swingings to-and-fro. (2) The act of causing a periodically moving body to lose its energy of motion by the application of retarding forces.

Damping Coil for Galvanometer.—(1) An auxiliary coil employed with a galvanometer for receiving transient electric currents from a key under the control of an observer, for the purpose of checking the motion of the needle. (2) A short-circuited coil, on or near a movable electromagnetic system, for the purpose of damping its oscillations by the action of electric currents induced therein.

Damping, Electric.—A term sometimes employed for the decrease in the intensity of the electric oscillations produced in a resonant circuit by electric resistance, under circumstances where some of the higher overtones are set up in the circuit.

Damping Magnet.—Any magnet employed for the purpose of checking the motions of a moving body or magnet.

Damping Suspension.—A suspension which is rendered dead-beat, or aperiodic, by the application of any retarding force or damping mechanism.

Damping Tube.—(1) A tube fitted with a glass cap and placed in an instrument to diminish the cavity in which a movable system swings, and thus damp its motion. (2) A conducting tube attached to a movable system and placed in the vicinity of fixed permanent magnets, in order to damp the vibrations of the system.

Damping Vessel.—A dash-pot.

Daniell's Voltaic Cell.—A zinc-copper couple whose elements are immersed respectively in electrolytes of dilute sulphuric acid and a saturated solution of copper sulphate.

Dark Discharge.—A term applied by Faraday to that portion of the convective discharge which occurs, under certain circumstances, in the rarefied gas of an exhausted chamber between the positive and negative electrodes.

Dark-Light Frequencies.—Ether vibrations of the nature of light whose frequencies are too low to produce physiologically effective light.

Dark-Segment of Aurora.—A dark or non-illuminated portion of an aurora glory, or crown of auroral light.

Dash-Pot.—A mechanical device for preventing a too sudden motion in the movable part of any apparatus.

Day Load.—A load on an apparatus, machine, or central station, occurring during the daytime as distinguished from a night load.

Day of Magnetic Disturbance.—A day during which the mean departure of the reading of a declinometer at any place, from the normal monthly value at that place, is at least one and one-half times the average.

Daylight Color-Values.—Such values of luminous frequencies as correspond to those present in ordinary sunlight or daylight.

Dead-Beat.—(1) Heavily damped. (2) Aperiodic. (3) Such a motion of a galvanometer needle, or other suspension system, in which the needle moves sharply from point to point and comes quickly to rest.

Dead-Beat Discharge.—A non-oscillatory discharge.

Dead-Beat Galvanometer.—(1) An aperiodic galvanometer, or one whose needle comes quickly to rest instead of repeat-

- edly swinging to-and-fro. (2) A heavily damped galvanometer.
- Dead Beatness.**—Possessing the property of aperiodicity.
- Dead Dipping.**—Dipping in acid liquids for the purpose of obtaining a dead or unpolished surface on an electro-metalurgical coating or deposit.
- Dead Earth.**—(1) A fault in a telegraphic or other line, in which the line is thoroughly grounded or connected with earth. (2) A total earth. (3) An earth of inappreciable or insignificant resistance.
- Dead-Ended Conductor or Wire.**—A conductor or wire whose end is deliberately left open or insulated, as, for example, by being wound around an insulator.
- Dead Ending.**—Leaving a conductor dead-ended.
- Dead Ground or Grounding.**—Such a grounding as will ensure a ground of negligible resistance.
- Dead Man.**—A support for raising a pole and supporting it in place while securing it in the ground.
- Dead Points of Motor Armature.**—Any positions of a motor armature when at rest, in which the driving current cannot start it.
- Dead Resistance for Testing Bank.**—(1) A resistance for a testing bank devoid of inductance. (2) An inductionless resistance.
- Dead Wires.**—(1) Any disused wires or abandoned wires, generally aerial. (2) A term applied to that portion of the wire on a dynamo which produces no electromotive force on its movements through the field flux. (3) That part of the wire on a motor which produces no useful effect on the passage through it of a driving current.
- Dead Wires of Dynamo Armature.**—The wires on the armature of a dynamo or motor which produce no useful electromotive force or resulting current on the movement of the armature through the field of the machine.
- Dead Wires on Motor Armature.**—The wires on the armature of a motor which produce no useful torque on the passage through them of an electric current.
- Death, Electric.**—Death resulting from the passage of an electric discharge or current through the human body.
- Decalescence.**—An absorption of sensible heat that occurs at a certain time during the heating of a bar of steel.
- Decay of Waves.**—The diminution in the amplitude of waves due to obstruction of any kind.
- Deci.**—A prefix for the one-tenth part.
- Deci-Ampere.**—One-tenth of an ampere.
- Deci-Ampere Balance.**—A balance form of ammeter whose scale is graduated to give direct readings in deci-amperes.
- Deci-Lux.**—The one-tenth of a lux.
- Deci-Polar Dynamo.**—A dynamo whose field is produced by ten magnet poles.
- Decimal Candle.**—A photometric standard equal to the twentieth part of the Violle platinum standard.
- Deck Cable-Lead.**—Guide pulleys or leads, placed at suitable intervals on the deck of a cable ship, extending from a tank to the bow or stern sheaves, to aid in laying a submarine cable.
- Deck-Planer, Electric.**—An electrically driven rotary cutter or planer, suitable for planing the deck of a ship.
- Deflection of Magnet.**—The variation of a magnetic needle from the true geographical North.
- Deflection Compass.**—A declinometer.
- Declinometer.**—A magnetic needle suitably arranged for the measurement of the magnetic declination or variation of any place.
- Decohere.**—To restore or regain the natural condition of a coherer.
- Decomposition.**—The separation of a molecule into its constituent ions or radicals, or into its ultimate atoms.
- Decomposition, Electric.**—Chemical decomposition effected by means of an electric discharge or current.
- Decomposition, Electrolytic.**—The separation of a molecule into its constituent ions or radicals by the action of an electric current.
- Decorative Series Lamps.**—Series-connected incandescent lamps employed to obtain decorative effects.
- De-Energize.**—To deprive an electro-receptive device of its operating current.
- De-Energizing.**—Depriving an electro-receptive device of its operating current.
- Deep Sea-Cable.**—That portion of a submarine cable which is laid in the deep water, at a distance from the coast or shore.
- Deep-Seated Eddy-Currents.**—The eddy currents that are set up in the mass of a conductor subjected to electrodynamic induction, as distinguished

from the superficially-seated eddy-currents.

Deep-Water Submarine-Cable.—A deep sea cable.

Defective-Loop Repeater.—(1) A device for employing the good wire of a defective loop to an office, to receive and transmit alternately, on a duplex, or on the common side of a quadruplex set. (2) A repeater connecting a branch office with a duplex or quadruplex set at a main office, and arranged to operate on a single wire of a pair or loop to said branch office when the other wire becomes defective.

Deflagration.—A violent but not explosive combustion of a substance.

Deflagration, Electric.—The fusion and volatilization of metallic substances by the passage through them of an electric current.

Deflagrator.—The name given to a particular voltaic battery of small internal resistance, employed, in the early history of the voltaic battery, for the electric deflagration of metallic substances.

Deflecting Magnet.—(1) The permanent magnet of a magnetometer, employed for deflecting a small magnetic needle suspended at a definite distance, in order to compare its influence with that of the earth's horizontal magnetic force. (2) The compensating magnet of a galvanometer.

Deflection Method.—A method employed in electrical measurements in which, as distinguished from the zero method, the amount of the deflection produced on any instrument, by a given current or a given charge, is utilized for determining the value of that current or charge.

Deflection of Cable Dynamometer.—(1) The sag, or distance to which a cable dynamometer sheave descends below the horizontal line corresponding to infinite tension. (2) The sag of a dynamometer sheave which increases as the strain on the cable diminishes.

Deflection of Magnetic Needle.—The movement of a needle out of a position of rest, either in the earth's magnetic field, or in the field of another magnet, by the action of the flux of an electric current or of a magnet.

Deformation.—(1) Any displacement of the particles of a solid with reference to one another, produced by the action of a stress. (2) A strain.

Degeneration of Cell.—Such a change in the muscular or cellular structure of a cell that incapacitates it from performing its ordinary functions.

Degeneration of Energy.—A degradation of energy.

Deka.—A prefix signifying ten times.

Deka-Ampere.—Ten amperes.

Deka-Ampere Balance.—A balance-form of ammeter measuring tens of amperes (0 to 100 amperes.)

Deliquescence.—The solution of a crystalline solid arising from its absorption of the vapor of water from the atmosphere.

Delivered Power.—In a system of electrical transmission, the power that is delivered at one end of a line as distinguished from the power sent into the line at its other end.

Delta Connection.—The connection of circuits employed in a delta triphase-system.

Delta Current.—(1) The current between adjacent wires or terminals of a triphase-system. (2) The ring current.

Delta Potential of Triphase System.—(1) The effective difference of potential, or voltmeter pressure, between adjacent wires or terminals of a triphase-system. (2) The ring potential.

Delta Triphase-System.—A triphase system in which the terminal connections resemble the Greek letter delta, or triangle.

Demagnetizable.—Capable of being deprived of magnetism.

Demagnetization.—The act of depriving a magnet of its magnetism.

Demagnetization by Successive Reversals.—A process for removing the magnetism from a mass of steel, as in a watch, by subjecting it to many successive magneto-motive forces alternating in direction and gradually diminishing to zero.

Demagnetize.—To deprive of magnetism.

Demagnetizing.—Depriving of magnetism.

Demagnetizing Current.—The current which serves to remove the magnetization of some magnetic device.

Demagnetizing Lines of Flux.—Magnetic flux produced by a magnetized bar in a direction opposite to the magnetizing force, and tending, therefore, to demagnetize the bar.

Demand Recording-Meter.—A meter which registers the maximum demand for electric energy, usually a meter which registers the maximum current strength supplied through it, in addition to the total quantity of electricity delivered.

- Demarcation Current.**—A term sometimes applied to the electric current obtained from an injured muscle.
- Density, Electric.**—The quantity of free electricity on any unit of area of surface of a charged body.
- Density of Charge.**—The quantity of electricity per-unit-of-area at any part of a charged surface.
- Density of Current.**—The quantity of current that passes per-unit-of-area of cross-section in any part of a circuit.
- Density of Electrification.**—The density of an electrostatic charge.
- Density of Field.**—The quantity of magnetic flux that passes through any field per-unit-of-area of cross-section.
- Dentiphone.**—An audiphone.
- Dephased.**—(1) Differing in phase. (2) Caused to differ in phase.
- Depolarization.**—The act of reducing or removing the polarization of a voltaic cell or battery.
- Depolarize.**—To deprive of polarization.
- Depolarizer.**—The material employed in voltaic cells for the purpose of depolarizing them.
- Depolarizing.**—Depriving of polarization.
- Depolarizing Fluid or Liquid.**—An electrolytic fluid or liquid employed in a voltaic cell for the purpose of preventing or lessening polarization.
- Depositing Cell or Vat.**—Any electrolytic cell in which an electro-metallurgical deposit is made.
- Deposition, Electric.**—The deposit of a substance, generally a metal, by the action of electrolysis.
- Deprez-D'Arsonval Galvanometer.**—A form of dead-beat galvanometer.
- Derivation.**—(1) A shunt or derived circuit. (2) A leak.
- Derivative or Derived Current.**—The current that flows through a branch or derived circuit.
- Derived Circuit.**—(1) A branch or shunt circuit. (2) A derivation.
- Derived-Circuit Arc-Lamp.**—The name sometimes employed for a differential arc-lamp.
- Derived Units.**—Various secondary units obtained or derived from the fundamental units of length, mass, and time.
- Desk Loop.**—(1) In telegraphy, a loop or circuit, running to a desk in a telegraph office, and connecting the apparatus on such desk with main-line apparatus at some other table. (2) A circuit connect-
- ing an operator at one desk with a duplex or quadruplex set of apparatus at another desk for convenience in handling the traffic.
- Desk Push.**—An electric push attached to a desk for the purpose of ringing a call-bell, or closing some other electric circuit.
- Desk Set.**—Telephone apparatus arranged for use on a desk.
- Destructive Distillation.**—The action of heat on an organic substance while out of contact with air, resulting in the decomposition of the substance into simpler and more stable compounds.
- Detector Galvanometer.**—Any rough form of galvanometer or galvanoscope employed for detecting the presence of electric currents.
- Detector Peg.**—A peg used in connection with a detector galvanometer.
- Detonating Fuse.**—(1) A fuse that is exploded by a percussion or blow. (2) A percussion fuse.
- Detorsion Bar.**—A bar placed in a magnetic declinometer for the purpose of removing the torsion on the suspending thread of the magnet.
- Developed Winding.**—A winding of a dynamo-electric machine developed or expanded upon a drawing or plane.
- Devil Claws.**—A device employed in stringing overhead wires.
- Dextrorsal Helix.**—A name sometimes applied to a dextrorsal solenoid.
- Dextrorsal Solenoid.**—A solenoid whose winding is right-handed.
- Diacritical Current.**—Such a strength of a magnetizing current as produces a magnetization of an iron core equal to one-half saturation.
- Diacritical Number.**—Such a number of ampere turns at which a given core would receive a magnetization equal to one-half saturation.
- Diacritical Point of Magnetic Saturation.**—A term proposed for such a value of the co-efficient of magnetic saturation that its core is magnetized to exactly one-half of its possible maximum magnetization.
- Diagometer.**—An apparatus in which an attempt is made to determine the chemical composition, and consequent purity, of certain substances by their electrical conducting powers.
- Dial Bridge or Rheostat.**—A resistance bridge or rheostat whose contact points are arranged in the shape of a dial.

- Dial Telegraph.**—A general term embracing the apparatus employed in dial telegraphy.
- Dial Telegraphy.**—A system of telegraphy in which the messages are received by the movements of a needle over a dial plate.
- Dialysis.**—The act of separating a liquid mixture into its crystalloids and colloids by passing the liquid through a membrane.
- Dialyzing.**—Subjecting to the process of dialysis.
- Diamagnetic.**—The property possessed by substances like bismuth, phosphorus, antimony, zinc and others, of being apparently repelled when placed between the poles of powerful magnets.
- Diamagnetic Permeability.**—The permeability to magnetic flux possessed by diamagnetic substances.
- Diamagnetic Polarity.**—A polarity, the reverse of ordinary magnetic polarity, the existence of which was assumed to explain the phenomena of diamagnetism.
- Diamagnetically.**—In a diamagnetic manner.
- Diamagnetism.**—A name sometimes given to the magnetism of diamagnetic bodies.
- Diamagnetized.**—Subjected to the action of so-called diamagnetism.
- Diamagnetometer.**—A magnetometer designed for the study of diamagnetism.
- Diamagnets.**—Diamagnetic substances subjected to magnetic induction, and formerly called diamagnets in contradistinction to ordinary or paramagnets.
- Diameter of Commutation.**—(1) The diameter of the commutator cylinder of a dynamo at which the brushes are applied. (2) That diameter on the commutator cylinder of an open-circuited armature, which joins the points of contact of the collecting brushes.
- Diaphragm.**—(1) A sheet of an elastic solid, generally circular in shape, securely fastened at its edges and capable of being set into vibration. (2) The porous wall or septum of an endosmometer. (3) The porous partition of a voltaic cell. (4) A disc of blackened metal provided with a circular aperture and employed for cutting off all the light from a lens except that falling on its central portions.
- Diaphragm Currents.**—Electric currents produced by forcing a liquid through the capillary pores of a diaphragm.
- Diaphragm of Voltaic Cell.**—(1) The porous partition or plate of a voltaic cell. (2) Generally, a porous cell.
- Diaphragm Photometer.**—A photometer which depends on the equality of the brightness obtained on the two halves of a diaphragm or screen, either by varying the distances of the lights from the screen or by varying the inclination of the luminous rays thereon.
- Dice-Box Insulator.**—A name sometimes applied to a double-cone insulator.
- Dielectric.**—Any substance which permits electrostatic induction to take place through its mass.
- Dielectric Absorption.**—The absorption of a charge or current by a dielectric.
- Dielectric Capacity.**—A term employed in the same sense as specific inductive capacity.
- Dielectric Circuit.**—A circuit formed in whole or in part through a dielectric as opposed to a conducting circuit.
- Dielectric Constant.**—A term sometimes employed in place of specific inductive capacity.
- Dielectric Current.**—(1) The rate-of-increase of the polarization of a dielectric produced by a change in the polarization through the circuit. (2) A displacement current.
- Dielectric Density of a Gas.**—A term sometimes employed instead of dielectric strength of a gas.
- Dielectric Displacement.**—(1) Electric displacement taking place through a dielectric. (2) The electromotive intensity in a dielectric multiplied by 4π and divided by the dielectric co-efficient.
- Dielectric Elasticity.**—(1) The reciprocal of the dielectric co-efficient. (2) The measure of the electric force that must be exerted upon a dielectric in order to effect unit displacement.
- Dielectric Energy Current.**—That component of an alternating current passing through a condenser which is in phase with the impressed E. M. F. at its terminals.
- Dielectric Hysteresis.**—(1) A variety of molecular friction, analogous to magnetic hysteresis, produced in a dielectric under changes of electrostatic stress. (2) That property of a dielectric by virtue of which energy is consumed in reversals of electrification.
- Dielectric Hysteretic Admittance.**—(1) In an alternating-current circuit the apparent component of admittance due to dielectric hysteresis. (2) In a condenser traversed by an alternating current the admittance, which is the geometrical sum of the hysteretic conductance and the hy-

- steretic susceptance, or whose reciprocal is the vector hysteretic impedance.
- Dielectric Hysteretic Impedance.**—In an alternating-current circuit, the apparent component of impedance due to dielectric hysteresis.
- Dielectric Hysteretic Lag.**—Lag in an alternating-current circuit due to dielectric hysteresis.
- Dielectric Medium.**—Any medium capable of acting as a dielectric.
- Dielectric Polarization.**—(1) The polarization of a dielectric by means of which electric induction takes place. (2) Dielectric displacement.
- Dielectric Resistance.**—(1) The resistance which a dielectric offers to mechanical strains produced by electrification. (2) The resistance of a dielectric to displacement currents.
- Dielectric Static Hysteresis.**—Hysteresis occurring in a dielectric under successive electric reversals, and due to a quasi-electrostatic friction independent of the rate of reversal, as distinguished from dielectric viscous hysteresis which varies with the frequency of cyclic electric reversals.
- Dielectric Strain.**—(1) The strained condition of the glass or other dielectric of a condenser produced by the charging of the condenser. (2) The deformation of a dielectric under the influence of an electro-magnetic stress.
- Dielectric Strength of Gas.**—The electromotive intensity a gas is capable of bearing without permitting a disruptive discharge to pass through it, and capable of measurement in volts per centimetre.
- Dielectric Stress.**—(1) The electro-magnetic force producing a deformation or strain in a dielectric. (2) Electromotive intensity.
- Dietrine.**—A name given to a variety of insulating material.
- Difference of Potential.**—That quantitative property in space by virtue of which work is done when a mass of any kind is moved from one point to another.
- Difference of Electric Potential.**—(1) That quantitative property in space whereby work is done when an electric charge is moved therein. (2) The electric work done on a unit charge in an excursion between two points.
- Difference of Magnetic Potential.**—(1) That quantitative property in space whereby work is done when a magnetic pole moves therein. (2) The magnetic work done on a unit magnetic pole in an excursion between two points.
- Difference of Tension.**—A term sometimes incorrectly employed for difference of potential.
- Difference of Thermal Pressure.**—A phrase sometimes employed for the difference of temperature between any two points in a conducting substance that is assumed to cause the flow of heat through that conductor from the higher to the lower temperature.
- Difference Theory of Muscle and Nerve Currents.**—A theory proposed to explain the cause of the electric currents in living tissues, by an alteration or change in the protoplasm, by injury, by differences of temperature, or by polarization.
- Differential Coils.**—Coils that are differentially wound, or that act differentially.
- Differential Compound Motor.**—(1) A compound motor in which the magneto-motive force of the working current is opposed to the magneto-motive force of the shunt excitation, for the purpose of maintaining the speed constant under all loads. (2) A compound-wound continuous-current motor.
- Differential Electric Arc-Lamp.**—A term formerly employed for a derived-circuit arc-lamp, in which the lifting magnet either consists of a core or solenoid wound with series and shunt coils, or of two separate and opposed cores, one of which contains the series and the other the shunt winding.
- Differential Electric Bell.**—An electric bell whose magnetizing coils are differentially wound.
- Differential Electro-Dynamometer.**—(1) A double dynamometer with two moving coils rigidly connected and oppositely acted on, so that the movement of the suspension system can be reduced to zero by electrical adjustments made while the instrument is under operation. (2) A dynamometer for measuring the difference between two electro-dynamic forces.
- Differential Electro-Magnet.**—A differentially-wound electro-magnet.
- Differential Equation.**—An equation connecting quantities into which one or more differential coefficients or differentials enter.
- Differential Galvanometer.**—A galvanometer containing two coils, so wound as to tend to deflect its needle in opposite directions.

Differential Induction Coil.—(1) An induction coil employed in duplex and quadruplex telegraphy, having two differentially-wound primary coils, one of which is placed in the main line of the circuit, and the other in the circuit of an artificial line. (2) In telephony, an induction coil which sometimes forms part of the equipment of a multiple switchboard operator.

Differential Inductometer.—A galvanometric apparatus for measuring the momentary currents produced by the discharge of a cable.

Differential Magnetometer.—A magnetometer having a divided magnetic circuit and a needle differentially acted upon by the branches.

Differential Method of Duplex Telegraphy.—A system of duplex telegraphy in which the coils of the receiving and transmitting instruments are differentially wound.

Differential Method of Quadruplex Telegraphy.—A system of quadruplex telegraphy by means of a double-differential duplex system.

Differential Permeability.—The differential coefficient of flux density to magnetizing force in a substance undergoing magnetization.

Differential Relay.—A telegraphic relay containing two differentially wound coils of wire on its magnet core.

Differential Speed.—In an induction machine, the angular velocity of the field relatively to the rotor.

Differential Susceptibility.—The differential coefficient of the magnetic intensity to the magnetizing force in a substance undergoing magnetization.

Differential Thermo-Pile.—A thermopile whose two opposite faces are exposed to the action of two nearly equal sources of heat, in order to determine accurately the difference in the thermal intensities of such sources of heat.

Differential Voltmeter.—A voltmeter consisting of two separate decomposition cells, one placed in a circuit of known resistance, and the other in a circuit whose resistance is to be determined.

Differential Winding.—Such a double winding of magnet coils that the two poles produced thereby are opposed to each other.

Differential Winding of Field.—(1) A field-magnet winding in which two exciting currents exert opposing magnetomotive forces. (2) A form of winding

in which the magnetizing flux of the series coil is opposed by the magnetizing flux of the shunt coils.

Differentially-Wound Dynamo-Electric Machine.—A compound-wound dynamo-electric machine.

Differentially-Wound Motor.—A compound-wound motor, in which the current in the shunt coils opposes, in its magnetizing effects, the current in the series coil, so that the efficient magnetizing effect produced is the difference between the magnetizing effects of the two coils.

Differentially Wound Translator.—In telephony, a translator having one primary and two equal secondary coils, employed in duplex working.

Diffraction Grating.—A plate containing a series of parallel linear openings, slits or scratches, separated by opaque or smooth spaces, employed for producing spectra by diffraction or interference.

Diffusing Globes for Electric Lights. Globes so constructed as to ensure a diffusion of the light around which they are placed.

Diffusion Creep.—A term sometimes used for the diffusion of an electric current.

Diffusion of Electric Current.—The flow of an electric current in the portions of a conducting substance that lie outside the parts in the direct line between the points where the terminals of an electric source are applied, so that a difference exists in the density of the current at different points of such substance.

Diffusion of Electric Waves.—(1) The scattering of electric waves, or their deviation from a parallel beam. (2) The transmission of electric waves through a medium.

Diffusion of Electro-Therapeutic Current.—The differences in the density of current in different portions of the human body, lying between electro-therapeutic electrodes.

Diffusion of Lines of Force.—The diffusion of magnetic flux.

Diffusion of Magnetic Flux.—The lateral deflection of magnetic flux from the direct path between the poles that produce it.

Digging Spoon.—A spoon-shaped shovel used in digging holes for telegraph poles.

Dilation, Electric.—Electric expansion, or an increase in volume, produced in a body by an electric charge.

Dilatometer.—An instrument resembling a thermometer, employed in measuring the expansion of a liquid by heat.

Dimensions of Electro-Magnetic

Units.—The conventional exponential values of electro-magnetic units in terms of the fundamental units of length, mass, and time.

Dimensions of Electrostatic Units.

The exponential values given conventionally to the units of the electrostatic system, in terms of the fundamental units of length, mass, and time.

Dimensions of Magnetic Units.

The exponential values given conventionally to the units of the magnetic system, in terms of length, mass, and time.

Dimensions of Units.

The exponential values given conventionally to units in terms of length, mass, and time.

Diminished Electric Irritability.

A decrease in the irritability of nervous or muscular tissue produced by a suitable electric current.

Dimmer.

A choking coil employed in an alternating-current system of distribution for regulating the current strength passing through incandescent lamps.

Diode Working.

A term employed for the two-way mode of telegraphic working established by the Delany Synchronous Multiplex Telegraphic System.

Diopeter.

A unit of the refracting or focal power of a lens.

Dioptre.

An orthography commonly employed for diopeter.

Dioptric.

An orthography sometimes employed for diopeter.

Dioptric.

Of or pertaining to dioptries.

Dioptric Shade.

A shade for a luminous source made of refractive material, which prevents the light from passing, in certain directions, by reason of its refractive power.

Dioptries.

The science which treats of the refraction of light.

Dioptry.

An orthography frequently employed for diopeter.

Dip.

The inclination of a magnetic needle.

Dip Circle.

A dipping needle provided with means for accurately measuring the angle of dip.

Dip of Line-Wire or Conductor.

The sag, due to its weight, of an aerial conductor between any two of its adjacent supports.

Diphase - Alternating Currents.

(1) Two separate alternating electric currents whose phase difference is a quarter of a cycle. (2) Two-phase currents. (3) Quarter-phase currents.

Diphase-Alternating E. M. F.'s.

(1) Two separate alternating-electromotive forces whose phase difference is a quarter of a cycle. (2) Two-phase E. M. F.'s. (3) Quarter-phase E. M. F.'s.

Diphase Alternator.

An alternator that produces diphase E. M. F.'s.

Diphase Armature.

The armature of a diphase alternator, or diphaser.

Diphase Armature-Winding.

Any armature winding capable of furnishing diphase currents.

Diphase Circuit.

A circuit, consisting either of three or four separate wires, employed for the transmission of diphase currents.

Diphase Field.

A diphase magnetic field.

Diphase Generator.

(1) A generator capable of producing diphase E. M. F.'s.

(2) A diphase alternator.

Diphase Inter-Connected Circuit.

(1) A diphase circuit consisting of two outgoing conductors, one for each phase or side of the system, and a single return-conductor common to both. (2) A diphase system in which the two diphase circuits are not electrically separated or independent.

Diphase Magnetic-Field.

A magnetic field produced by diphase currents.

Diphase Motor.

A motor suitable for use with diphase electric currents.

Diphase Rotary-Field.

(1) A magnetic field produced by four or more magnet poles whose coils are so wound that their polarity not only alternates with changes in the direction of the current, but acts as though the field rotated. (2) A rotating magnetic field produced by diphase currents.

Diphase Transformer.

A polyphase transformer suitable for use with diphase currents.

Diphase-Triphase Transformer.

A transformer for converting diphase into triphase currents.

Diphaser.

A word sometimes used for diphase alternator.

Diplex Circuit.

The circuit, including the line wire and apparatus, employed in any diplex system.

Diplex Telegraph.

A general term embracing the apparatus employed in diplex telegraphy.

Diplex Telegraphy.

Any method by which two telegraphic messages can be simultaneously sent in the same direction over a single wire.

- Diplex Telephony.**—Any method by which two telephone messages can be simultaneously sent in the same direction over the same wire.
- Diplex Transmission.**—The simultaneous telegraphic or telephonic transmission of two messages in the same direction over a single wire.
- Dipolar.**—(1) Possessing two poles. (2) Bipolar.
- Dipping.**—(1) An electro-metallurgical process whereby a thin coating or deposit of metal is obtained on the surface of another metal by dipping it in a solution of a readily decomposable metallic salt. (2) Cleansing surfaces for electro-plating, by immersing them in various acid liquors.
- Dipping Basket.**—A perforated basket of non-corrosive material, employed in electro-plating, for the reception of articles that are to be cleansed by dipping.
- Dipping Hook.**—A metallic hook employed in electro-plating for holding articles that are to be cleansed by dipping.
- Dipping Magnetic-Needle.**—(1) A magnetic needle suspended so as to be free to move in a vertical plane only, and employed to determine the angle of dip or magnetic inclination. (2) An inclination compass.
- Dipping Needle.**—A term sometimes used for a dipping magnetic needle.
- Dipping Wire.**—The wire employed in electro-metallurgy for suspending small articles that are to be cleansed by dipping.
- Dips.**—Acid liquors employed in dipping.
- Direct-Coupled Dynamo.**—A dynamo whose armature shaft is directly coupled to the driving shaft.
- Direct Coupling.**—Coupling the shaft of a dynamo armature directly to the driving or engine shaft.
- Direct-Current.**—(1) A current whose direction is constant, as distinguished from an alternating current. (2) A continuous current.
- Direct-Current Dynamo-Electric Machine.**—Any dynamo-electric machine capable of furnishing direct currents.
- Direct-Current Electric Motor.**—An electric motor driven by means of direct or continuous currents, as distinguished from a motor driven by alternating currents.
- Direct-Current Rotary Transformer.**—(1) A term sometimes employed for a rotating secondary generator of continuous currents. (2) A motor-dynamo or dynamotor.
- Direct-Current Transformer.**—(1) A transformer intended to vary the strength of continuous currents. (2) A direct-current secondary-generator.
- Direct-Driven Dynamo of Generator.**—A direct-coupled dynamo or generator.
- Direct-Deflection Method of Measuring Resistance.**—A method of measuring resistance based on the deflection of a galvanometer in circuit with a resistance and a battery.
- Direct-Electromotive Force.**—(1) An electromotive force acting on a circuit in the same direction as another electromotive force already existing in that circuit. (2) The electromotive force acting on any circuit in contra-distinction to the counter-electromotive force set up in such circuit. (3) A continuous-electromotive force as distinguished from an alternating-electromotive force.
- Direct Excitation.**—(1) The excitation of a muscle, resulting from the placing of an electrode directly on the muscle itself. (2) The excitation of a dynamo electric machine by a separate source of direct currents, as distinguished from its excitation by commuted currents taken from its own armature.
- Direct-Induced Current.**—The break-induced current.
- Direct Inker.**—An ink-writing Morse recorder, wound for insertion in a telegraphic line, as distinguished from one wound for a local circuit.
- Direct Lightning-Discharge.**—The actual lightning discharge, as distinguished from the back or return-stroke or discharge.
- Direct-Reading Galvanometer.**—A galvanometer in which the absolute value of the deflection and current strength are indicated directly, or without computation.
- Direct Sounder.**—A telegraphic sounder wound for a line circuit and not for use in the local circuit of a relay.
- Direct-Reading Potentiometer.**—A potentiometer which indicates directly on its scale the pressure measured at its terminals.
- Direct Working of Telegraphic Sounder.**—The working of a telegraphic sounder without the use of a telegraphic relay.
- Directed Streaming-Discharge.**—A Tesla or high-frequency discharge which

- assumes the shape of a highly luminous cone.
- Directing Clock.**—A controlling or master clock.
- Directing Magnet.**—A controlling or compensating magnet.
- Direction of Electric Current.**—A convention whereby an electric current is regarded as leaving a source at its positive pole, and re-entering it at its negative pole.
- Direction of Electrostatic Flux.**—A convention whereby it is assumed that electrostatic flux leaves a positively charged body at its positive pole, and terminates on a negatively charged body.
- Direction of Lines of Force.**—The direction of magnetic or electrostatic flux.
- Direction of Magnetic Flux.**—A convention whereby it is assumed that magnetic flux issues from a magnet at its north-seeking pole, and returns to it at its south-seeking pole.
- Direction of Negative Rotation.**—In the conventionally adopted system of kinetics, a clock-wise rotation about an axis as viewed from the front side of the clock.
- Direction of Positive Rotation.**—In the conventionally adopted system of kinetics the counter-clockwise direction of rotation about an axis as viewed from the front face of the clock.
- Directive Tendency of Magnetic Needle.**—The tendency of a magnetic needle to come to rest in the direction of the earth's magnetic flux.
- Disc Armature.**—(1) The armature of a dynamo-electric machine whose windings consist of flat coils supported on the surface of a disc. (2) An armature having the form of a disc.
- Disc Electrodes.**—Disc-shaped carbon electrodes formerly employed in long-burning or all-night arc-lamps.
- Discharge.**—(1) The equalization of the difference of potential between the terminals of a condenser or source, on their connection by a conductor. (2) The removal of a charge from a conductor by connecting the conductor to the earth or to another conductor. (3) The removal of a charge from an insulated conductor by means of a stream of electrified air particles.
- Discharge.**—To equalize differences of potential by connecting them by a conductor.
- Discharge Key.**—A key employed to pass the discharge from a condenser or cable through a galvanometer.
- Discharge of Magnetism of Field Magnets.**—A term sometimes employed for the unbuilding of a dynamo, or its gradual failure to produce current on the loss of magnetism of its field magnets.
- Discharging Rate.**—The strength of the discharging current of a storage cell or battery.
- Discharge Resistance.**—The resistance that is placed in the path or circuit of a discharge.
- Discharging Rod.**—A jointed metallic rod, blunted at both ends, capable of adjustment as to the distance of the ends from each other, and provided with insulating handles, employed for the disruptive discharge of Leyden batteries or condensers.
- Discharging Tongs.**—A pair of discharging rods with an insulating handle, connected together by a rivet like a pair of tongs, for effecting the disruptive discharge of a Leyden jar or condenser.
- Discoidal Ring-Armature.**—A term sometimes used for disc armature.
- Discoidal Winding.**—The flat-ring winding employed in a disc armature.
- Disconnect.**—(1) To break or open an electric circuit. (2) To remove an electro-receptive device from a circuit.
- Disconnecting.**—The act of opening or breaking a circuit, or of removing electro-receptive devices therefrom.
- Disconnecting Plug.**—An infinity plug.
- Disconnection.**—(1) A general term designating a variety of faults caused by the accidental breaking or disconnection of a circuit. (2) The intentional opening or breaking of a circuit, or the removal of an electro-receptive device therefrom. (3) A discontinuity in a circuit.
- Disconnecter.**—A key or other device for opening or breaking an electric circuit, or for removing an electro-receptive device therefrom.
- Discontinuity Plug.**—A name sometimes employed for an infinity plug.
- Discriminating Lightning-Arrester.**—The name sometimes applied to a non-arcing continuous-current lightning-arrester.
- Dielectrification.**—A general term employed for the act of causing a charged body to lose its electric charge.
- Disguised Electricity.**—Dissimulated or latent electricity.

- Disintegration of Storage Battery Plate.**—The gradual loosening or separation of the active material of a storage battery plate from the perforations of the grid.
- Disjuncter.**—A device employed in a system for the distribution of electric energy by means of continuous currents in connection with condensers, for periodically reversing the constant current sent over the line.
- Dispersing Pad-Electrode.**—A therapeutic pad-electrode, suitable for use with strong currents, applied directly to the body, for diffusing the therapeutic current through a large tract thereof.
- Dispersion Photometer.**—A photometer in which the light to be measured is decreased in intensity by a known amount, so as to be more readily compared with a standard light of much smaller intensity.
- Displacement Current.**—(1) The rate-of-change of electric displacement. (2) An electric current produced in a dielectric by electric displacement, as opposed to a conduction current.
- Displacement, Electric.**—A displacement of electricity in a uniform non-crystalline dielectric when electrostatic flux passes through it.
- Displacement Flux.**—(1) The flux of electric displacement. (2) The surface integral of displacement effected through the surface.
- Displacement Lines.**—The lines along which displacement flux moves.
- Displacement Waves.**—Waves produced in the ether by means of electric displacements.
- Disruptive Discharge.**—A sudden and more or less complete discharge that takes place across an intervening non-conductor or dielectric.
- Disruptive Electric-Conduction.**—The conduction of electric energy which accompanies a disruptive discharge.
- Disruptive Strength of Dielectric.**—The strain a dielectric is capable of bearing without suffering disruption, or without permitting a disruptive discharge to pass through it.
- Dissipation Function.**—(1) A function expressing the rate at which heat is produced by the passage of an electric current through a conductor. (2) A function, which, when differentiated with respect to a velocity as the independent variable, gives the applied force required to overcome the dissipative resistance to motion.
- Dissipation of Charge.**—The gradual but final loss of charge by leakage which occurs even in a well insulated conductor.
- Dissipation of Energy.**—The expenditure or loss of available energy.
- Dissipativity.**—The time-rate of dissipating energy as heat per-unit-volume of a substance.
- Dissimulated Electricity.**—(1) A term sometimes applied to the condition of an electric charge when placed near an opposite charge, as in a Leyden jar or condenser. (2) A bound charge.
- Dissociate.**—To separate a compound substance into its constituent parts.
- Dissociation.**—The separation of a compound substance into its constituents.
- Dissonance, Electric.**—(1) Electrical disagreement. (2) A term employed in contradistinction to electric consonance, to alternating electromotive forces, fluxes or currents, whose phases are in opposition.
- Dissymmetrical Alternating-Electromotive Forces.**—Alternating-electromotive forces, in which an alternating semi-wave, when reversed in sign, does not reduplicate the preceding or succeeding semi-wave.
- Dissymmetrical Induction of Armature.**—Any induction produced in the armature of a dynamo that is unequal in amount, in opposite or symmetrically disposed portions of the armature.
- Dissymmetrical Magnetic Field.**—A field whose flux is not symmetrically distributed.
- Dissymmetry of Commutation.**—A commutation in which the neutral line does not coincide with the diameter of commutation.
- Distant Battery.**—A battery employed in any telegraphic system at the distant receiving end of the line.
- Distant Station.**—A term applied by a telegraph operator to the distant end of the line, in order to distinguish it from his own, or the home end.
- Distillation, Electric.**—The distillation of a liquid in which the effects of heat are aided by the electrification of the liquid.
- Distorsion.**—The change in the shape or configuration of a medium, or an entity, produced by the action of a stress or disturbance.
- Distorsion of Magnetic Field.**—A change in the direction or distribution of the magnetic flux in the field of a dynamo.

armature, produced by the magnetomotive force of the armature current.

Distorsional Elasticity.—Elasticity in a body, due to its distorsion or deformation.

Distorsionless Cable.—A cable that forms part of a distorsionless circuit.

Distorsionless Circuit.—(1) A telegraphic circuit in which leakage and conductor resistance are so balanced as to leave no tailings. (2) A telegraphic circuit in which there is no distorsion of signals or electric waves.

Distributed Capacity.—The capacity of a circuit considered as distributed over its entire length, so that the circuit may be considered as shunted by an infinite number of infinitely small condensers, placed infinitely near together, as distinguished from localized capacity, in which the capacity is distributed in discrete aggregations.

Distributed Inductance.—Inductance distributed throughout the entire length of a circuit or portion thereof, as distinguished from inductance interposed in a circuit in bulk at some one or more points.

Distributed Winding of Dynamo Electric Armature.—A winding disposed regularly over the surface of the armature as distinguished from a pole winding, or a winding composed of a few localized coils.

Distributing Board.—(1) A term sometimes employed in a system of telephonic or telegraphic communication, to a cross-connecting board. (2) A board at which the wires or cables from a telephone switchboard terminate and at which connections are made with the circuit wires. (3) An insulating board provided with screw connecting-pieces for readily connecting branch circuits to mains in a distributing system, with or without fuse cut-outs.

Distributing Box.—(1) A box containing means for readily changing the connections of distribution circuits with their source of supply. (2) A device by means of which both arc and incandescent lights may be simultaneously employed on the same constant-current circuit. (3) A device for cutting into or out of an arc circuit, at will, a group of series incandescent lamps.

Distributing Box of Conduit.—A name sometimes given to a man-hole of a conduit.

Distributing Brushes of Motor.—The brushes which rest on the commutator of an electric motor and carry the driving current to it.

Distributing Mains.—The mains employed in a feeder system of parallel distribution.

Distributing Point.—A point, usually at the junction of risers and mains, or mains and sub-mains, where all the fuses or safety catches, belonging to that part of the system, are collected.

Distributing Station.—(1) A station from which electricity is distributed. (2) A central station.

Distributing Switch.—A switch for closing a plurality of distributing circuits at will upon the source of supply.

Distributing Switchboard.—(1) A multiple switchboard. (2) A device for distributing electricity over any of a number of circuits.

Distributing Box.—A box placed at a distributing point for holding all the fuses belonging to that portion of the distributing system.

Distributing Box for Arc-Light Circuits.—A device by means of which both arc and incandescent lights may be simultaneously employed on the same line from a constant-current dynamo-electric machine.

Distributing Centre.—(1) In an electrical distribution system a centre or sub-centre of distribution. (2) A ramifying point.

Distribution of Charge.—The diffusion or dispersion of an electric charge over the surfaces of electrified bodies.

Distribution of Electricity.—The division and transmission of electric energy by means of various combinations of electric sources, circuits and electro-receptive devices, so arranged that the electricity generated by the sources is carried or distributed to more or less distant electro-receptive devices, by means of the various circuits connected therewith.

Distribution of Electricity by Alternating Currents.—A system of electric distribution in which the lamps, motors or other receptive devices, are operated by means of alternating currents that are sent over the line or lines, in many cases after they have been modified by apparatus called transformers.

Distribution of Electricity by Alternating Currents by Means of Condensers.—A system of alternating-current distribution in which condensers are employed to transform currents of high potential, received from an alternating-current dynamo, to currents of low potential which are fed to the lamps or other electro-receptive devices.

- Distribution of Electricity by Commutating Transformers.**—A system of electric distribution in which motor generators are used, but neither their field-magnets nor armatures are revolved, a special commutator being employed to change the polarity of the magnetic circuits.
- Distribution of Electricity by Constant-Currents.**—Any system of electric distribution employing direct currents, as distinguished from one employing alternating currents.
- Distribution of Electricity by Constant Potential-Circuits.**—A system of electric distribution in which the receptive devices are placed in multiple or multiple-series across constant-potential mains.
- Distribution of Electricity by Continuous Currents by Means of Condensers.**—A system of distribution in which a continuous current is conducted to certain points in a line, where a disjuncter is employed to reverse it periodically, the reversed currents so obtained being directly used to charge condensers in the circuit of which induction coils are employed.
- Distribution of Electricity by Continuous Currents by Means of Transformers.**—A system for the transmission of electric energy by means of continuous or direct currents that are sent over the line to suitably located stations where motor-dynamos are used for transformers.
- Distribution of Electricity by Motor-Generators.**—A system of electric distribution in which a continuous high-potential current, distributed over the main line, is employed at the point where its energy is to be utilized for driving a motor, which in turn drives a dynamo whose current is employed to energize the electro-receptive devices.
- Distribution of Power, Electric.**—Any system in which mechanical energy is first converted into electro-magnetic energy and then distributed over a line wire or circuit to electric motors, which again change the electro-magnetic energy into mechanical energy.
- Distributor.**—A word sometimes applied to the distributing mains in a parallel system of distribution.
- District Call-Box.**—A box by means of which an electric signal is automatically sent over a telegraph line and received by an electromagnetic device at the other end of the line.
- Diurnal Currents.**—Earth currents through telegraph circuits of normal strength and executing diurnal cycles.
- Diurnal Inequality of Earth's Magnetism.**—Diurnal variations in the value of the earth's magnetic variation or inclination.
- Diurnal Load-Factor.**—(1) The ratio between the total number of units sent out from a station in twenty-four hours, to the amount which would have been sent out in the same time if the plant were working at its maximum load for the whole twenty-four hours. (2) The ratio of daily average to daily maximum load.
- Diurnal Variation.**—An approximately regular variation of the magnetic needle which occurs at different hours of the day.
- Divalent.**—(1) Possessing an atomicity or valency of two. (2) Bivalent.
- Divergence.**—(1) The integral of outwardly directed flux over the surface of an element of volume divided by that volume. (2) The opposite of convergence.
- Divergent Flux.**—(1) Flux that diverges or diffuses as it proceeds. (2) Flux that decreases in intensity along its path.
- Divergent Vector Quantity.**—A vector point function in space having divergence.
- Diverging-Lens Photometer.**—A photometer in which the intensity of the light to be measured is decreased by means of a diverging lens.
- Diverging Magnetic Flux.**—Magnetic flux that decreases in intensity and diverges or diffuses in direction along its path.
- Diversity Factor.**—A term proposed for the ratio of the average supply of electric power to a consumer to the maximum power supplied.
- Diviance.**—A term proposed for resistance to the flow of magnetic induction.
- Divided Circuit.**—(1) A branched or bifurcated circuit. (2) A term sometimes employed for multiple circuit.
- Divided Core.**—A laminated core.
- Divided Magnetic Circuit.**—A magnetic circuit which bifurcates or divides.
- Divided Telephone-Switchboard.**—A multiple telephone switchboard.
- Divided Touch.**—A term used in place of magnetization by separate touch.
- Divided Trolley Line.**—A term sometimes used for a sectional trolley line.
- Dividing Engine.**—(1) A mechanical device for dividing a thermometric, galvanos-

metric, or other scale, into equal parts.

(2) A device for dividing a tube or a scale into equal parts of a length, consisting essentially of a horizontal screw by means of which a carriage carrying suitable marking-gear can be moved along a parallel prismatic guide.

Division Operator.—A railway telegraph-operator in charge of a telegraph division or section of railway telegraph.

Doctor for Plating.—A device employed in electro-plating for coating surfaces that are too extended to be immersed at once in the plating bath.

Dolly.—A polishing brush employed in electro-plating, consisting of a number of calico rings suitably clamped together in a wooden holder for attachment to a lathe.

Domestic Telephone-Switchboard.—(1) A telephone switchboard located in a house for readily connecting different rooms. (2) A local telephone switchboard for connecting apartments in a residence.

Door-Bell Pull, Electric.—A circuit-closing device attached to a bell-pull and operated by the ordinary motion of the pull.

Door-Contact Lamp.—A contact which lights a lamp and permits it to remain lighted only while the door operating its circuit remains in a certain position.

Door-Opener, Electric.—An electro-magnetic device for opening a door from a distance.

Door Push.—A contact closed or opened by the opening or shutting of a door to give a notice of the movement at a distance, as in a burglar-alarm system.

Door Trigger.—A device by means of which notice is given of the opening or closing of a door or window.

Dot-and-Dash Code.—A term sometimes employed for the Morse telegraphic code.

Dotting Contact.—An electric contact obtained by the approach of one contact point towards another.

Double Alternation.—(1) A complete cycle or double vibration. (2) A complete to-and-fro movement.

Double Armature Windings.—Two separate armature windings applied symmetrically to a core, and whose ends are connected respectively to alternate commutator bars.

Double-Balance Relay.—In a closed-current system of alarm telegraphy, a pair of relays connected in series, one of which will close a local circuit if the main line current appreciably weakens, and the

other of which will close a local circuit if the main line current appreciably strengthens.

Double-Bar Switch.—A switch or reverser consisting of a pair of parallel metallic bars or strips which move together upon independent centres so as to make contact simultaneously upon one or more pairs of contacts.

Double-Block Duplex System.—A system of duplex telegraphy in which a condenser exists in both arms of the duplex bridge.

Double-Break Knife-Switch.—(1) A knife switch which breaks a circuit at two points. (2) A knife switch provided with a contact for both poles.

Double-Break Switch.—A term sometimes used for double-pole switch.

Double-Bracket Pole.—A pole employed in an overhead line for the support of a double bracket.

Double-Bracket Trolley Suspension.—In a double-track trolley road, a pole provided with two brackets, one extending over each track, and provided for holding the two trolley wires.

Double-Block Duplex System.—A duplex system on the Wheatstone bridge system, employing a condenser in each arm of the bridge.

Double-Break Switch.—(1) A double-pole switch. (2) A switch which breaks a circuit in two places, as distinguished from a switch which breaks a circuit at a single point only.

Double-Bronze Wire.—A conducting wire possessing great tensile strength, provided with an aluminium-bronze core, and a copper-brass envelope.

Double-Carbon Arc-Lamp.—An arc-lamp which will burn all night without recarboning, containing two sets of carbon electrodes so arranged that, when one set is practically consumed, the current is automatically switched to the other set.

Double-Circuit Dynamo.—A dynamo-electric machine provided with two separate circuits.

Double-Conductor Cable or Wire.—A cable or wire provided with two separate insulated conductors.

Double-Cone Insulator.—An insulator in which the line wire passes through and is supported by means of a tube consisting of two inverted, truncated cones, joined at their vertices.

Double-Connector.—A form of binding screw suitable for readily connecting two wires together.

Double-Contact Key.—A key suitable either for making two separate successive contacts, or for closing either of two circuits.

Double-Contact Push.—A push provided with two contacts so arranged that the pressure of a push opens one contact and closes the other.

Double-Contact Push Button.—A push-button provided with two contacts.

Double-Cord Multiple-Switchboard.—A multiple telephone switchboard in which connections are made by plugs and cords having two twin wires, as opposed to a switchboard in which single cord plugs are used.

Double - Cord Switchboard.—(1) A switchboard employing twin-wire or double-conductor connections. (2) A switchboard in which each connection is established through a pair of cords, as distinguished from a single-cord switchboard.

Double-Cup Insulator.—(1) An insulator consisting of two funnel-shaped cups, placed in an inverted position on the supporting pin, and separated from each other by a free air-space except at the ends which are connected. (2) A double-petticoat insulator.

Double-Curb.—A device for increasing the speed of telegraphic signalling by ridding the line of its charge before the next signal is sent, by sending more than one reversal of current with or without grounding the line, as distinguished from a single-curb.

Double-Curb Signalling.—Signalling by means of a double curb.

Double-Current Signalling.—(1) Signalling by means of currents that alternately change their direction. (2) Signalling in which the marking currents have one direction and the spacing currents the opposite direction.

Double-Current Telegraphic Working.—Telegraphing or operating by means of double currents.

Double-Current Translation.—(1) The automatic repetition of a telegraphic message by means of double currents. (2) Telegraphic translation employing double currents.

Double-Current Translator.—A telegraphic translator or repeater designed to operate on double-current transmission.

Double-Current Transmitter.—A transmitting instrument employed in a system of telegraphy in which the direction of the line current is alternately changed,

according to whether the key rests on its front or on its back stop.

Double-Current Working.—A method of telegraphic working or transmission by means of double currents.

Double-Curve Pull-Off.—A double-curve hanger.

Double-Curve Trolley Hanger.—A hanger provided for holding an overhead trolley wire, supported by a lateral strain in opposite directions, and employed, generally at the end of both single and double curves, and on intermediate points on double-track curves.

Double-Curve Trolley-Suspension.—Suspension by means of a double-curve trolley hanger.

Double-Deck Switchboard.—A switchboard arranged in two rows placed one above the other.

Double-Dielectric Refraction.—Double electric refraction produced in a dielectric by the action of an electro-magnetic stress.

Double-Duplex Block.—In submarine telegraphy, duplex transmission obtained by the aid of a condenser inserted in each arm of a Wheatstone's balance.

Double-Filament Lamp.—(1) An incandescent lamp, frequently employed for the side-light of a ship, and provided with two carbon filaments so arranged that should one break, the other will continue burning. (2) A twin-filament lamp. (3) An incandescent lamp having two filaments connected in series, and, therefore, requiring twice the electric pressure of an ordinary lamp.

Double-Flexible Conductor.—A conductor consisting of two separate stranded flexible conductors, provided with an insulating covering common to both.

Double-Fluid Electrical Hypothesis.—A hypothesis which endeavors to explain the causes of electrical phenomena by the assumption of the existence of two different electric fluids.

Double-Fluid Voltaic Cell.—(1) A voltaic cell in which two separate fluids or electrolytes are employed. (2) A two-fluid voltaic cell.

Double-Focus X-Ray Tube.—An X-ray tube, suitable for use with alternating electric currents, in which two anti-cathodes are employed, so arranged that they act as a common source of X-rays.

Double-Hatchet Switch.—A term sometimes used for a double-knife switch.

- Double-Horseshoe Field-Magnet.**—A multiple field-magnet of a dynamo formed by two separate electro-magnets.
- Double Insulation.**—Insulation of a conductor effected at two distinct points, so that if one insulation should fail the other will serve.
- Double-Key Tapper.**—A key used in a system of needle telegraphy to send electric impulses through the line in alternately opposite directions.
- Double-Liquid Voltaic Cell.**—A double-fluid voltaic cell.
- Double-Loop.**—(1) In telegraphy, any pair of associated loops. (2) A pair of loops connecting a pair of branch offices with a central office.
- Double-Loop Repeater.**—In telegraphy, a pair of loops connecting a pair of branch offices with a central office, and so connected with a duplex set, or with the common side of a quadruplex set, in the main office, that one branch office can send messages on the duplexed line while the other office is receiving.
- Double-Magnet Dynamo-Electric Machine.**—A term sometimes applied to a dynamo-electric machine, whose field magnets have two consequent poles.
- Double-Needle Telegraphy.**—A system of needle telegraphy in which two separate and independently operated needles are employed on two separate circuits.
- Double-Peg.**—A split peg which closes two separate contacts, when inserted in the switchboard to which it belongs.
- Double-Pen Telegraphic-Register.**—A telegraphic register provided with two separate styluses or pens for recording the message on a paper fillet.
- Double-Petticoat Insulator.**—(1) A double insulator, placed one within and beneath the other, to reduce the electric leakage over the surface. (2) A double-cup insulator.
- Double-Plug.**—A double peg.
- Double-Plug Key.**—A plug key made in two separate parts that are insulated from each other.
- Double-Pole Bell.**—An electro-magnetic bell having a polarized armature which plays between a pair of electro-magnetic poles.
- Double Pole.**—(1) A double telegraph pole. (2) Two telegraph poles placed side-by-side and braced together. (3) An H-pole.
- Double-Pole Cut-Out.**—(1) A cut-out which provides in a single operation the cutting out of both the positive and the negative leads. (2) Two safety fuses, mounted on the same holder, and connected respectively to the positive and negative mains.
- Double-Pole Fusible Cut-Out.**—A term sometimes used for double-pole cut-out.
- Double-Pole Safety-Fuse.**—An automatic double-pole cut-out.
- Double-Pole Switch.**—A switch which simultaneously breaks the circuit of both positive and negative leads.
- Double-Pole Telephone-Receiver.**—A telephone receiver in which both poles of a small electro-magnet are presented to the diaphragm.
- Double Pull-Off.**—(1) A pull-off employed on curves to hold a trolley wire in position when strain in both directions is necessary to hold it in place. (2) A double-curve pull-off.
- Double-Reduction.**—A gear wheel velocity reducer employing two gear wheels and two pinions, or one intermediate shaft.
- Double-Reduction Car-Motor.**—A car-motor provided with a double-reduction, or with one intermediate gear shaft between the motor shaft and car wheel.
- Double-Reflection Tube.**—A term sometimes employed for a double-focus X-ray tube.
- Double-Refraction.**—The property possessed by certain transparent substances of splitting up a ray of light passed through them into two separate rays.
- Double-Refraction, Electric.**—The property of doubly refracting light acquired by some transparent substances when subjected to the stress of an electrostatic or electro-magnetic field.
- Double Ringing-Key.**—In a multiple telephone switchboard, a pair of keys forming part of an exchange operator's set, employed in ringing up.
- Double-Shackle Insulator.**—A form of insulator employed in shackling a wire, consisting of two single-shackle insulators.
- Double-Shed Insulator.**—A double-cup insulator.
- Double-Speaking Telegraph.**—A term sometimes employed for the duplex telegraph as employed on submarine cables.
- Double-Style Printing Apparatus.**—A double Morse receiver employing two printing levers or styluses marking dots in parallel lines, one responding to positive currents and representing dots, and the other responding to negative currents and representing dashes.

- Double-Successive Contact-Key.**—A key so arranged as to successively close two separate circuits.
- Double Tapper Key.**—A key employed in a system of needle telegraphy to send electric impulses over the line in alternately opposite directions.
- Double Telegraphic Transmission.**—Any method of simultaneously sending two messages over a single line wire or conductor.
- Double Telegraphy.**—A term sometimes employed for duplex telegraphic working.
- Double-Throw Switch.**—(1) A switch capable of being thrown into either of two contacts or pairs of contacts. (2) A switch which has three positions. (3) A throw-over switch.
- Double-Touch.**—Magnetization by double touch.
- Double-Transmission.**—(1) The simultaneous sending of two messages over a single wire in opposite directions. (2) Duplex or contraplex telegraphy.
- Double-Transmitter for Engine Telegraph.**—A transmitter on board a twin-screw steamer for communicating orders electrically to the engine-room for both engines simultaneously.
- Double-Trolley.**—Two separate trolleys placed on the same car, and moving over two separate trolley wires which form a metallic circuit, in any double-overhead system.
- Double-Trolley Line.**—A metallic-circuit trolley line employing two trolleys, one connected with the positive conductor and the other with the negative conductor.
- Double-Trolley System for Electric Railroads.**—An electric railroad system employing double trolley wires and double trolleys so as to provide a complete metallic circuit.
- Double-Truck Car.**—A car supported on two separate single trucks, and employed with long cars for safety and ease in turning around sharp curves.
- Double Vibration.**—(1) A to-and-fro or complete vibration. (2) A complete cycle of vibratory motion.
- Double-Winding of Armature.**—An armature winding provided with two separate windings or sets of coils, in which the separate windings are insulated from each other and connected to the commutator at alternate segments, so that the brushes rest coincidentally upon segments that are connected with each winding, thus permitting each winding to furnish half the current strength with an attendant decrease in the inductance of each circuit.
- Double-Wire Circuit.**—A metallic circuit.
- Double-Wire Cleat.**—A cleat for supporting a pair of wires.
- Double-Wire Moulding.**—A moulding for containing two wires, each in a separate groove.
- Double-Wire System for Electric-Light Leads.**—On board ship, a system of electric-light wiring, in which going and returning conductors are provided, as distinguished from a single-wire system in which the hull of the vessel is employed as a common return.
- Double-Wire Telephone-Switchboard.**—A switchboard in a central telephone exchange, employing metallic circuits, in which each subscriber is connected by an independent double wire or metallic circuit.
- Double-Word.**—In telegraphy, a word of more than the prescribed length and, therefore, counted and charged as two.
- Double-Wound Gramme Ring.**—A gramme ring provided with two independent and symmetrically interspersed windings.
- Double-Wound Wire.**—Wire provided with a double winding of cotton, silk, or other insulating thread.
- Doubler of Electricity.**—An early form of continuous electrophorous.
- Doubly Re-Entrant Armature-Winding.**—(1) A winding in which the armature is provided with two separate windings or conducting paths, each of which is independently re-entrant. (2) A double-wound armature, each winding of which is re-entrant.
- Doubly-Wound Resistance Coils.**—A resistance coil wound, as is usual, with the wire doubled on itself, in order to minimize self-induction.
- Douche, Electric.**—An electrified shower-bath.
- Down-Contact of Switch.**—A contact which is made by the downward movement of a switch.
- Down-Lines.**—In the United Kingdom of Great Britain and Ireland, telegraphic lines on the side remote from the principal station of the circuit, as distinguished from up-lines.
- Down-Side.**—In Great Britain, that side of a telegraphic circuit further from the metropolis or principal town of the circuit, as distinguished from the up-side.

Drag.—In submarine cable operations, a haul made with a grapnel across a line of cable in the hope of hooking said cable.

Drag of Magnetic Field.—A word sometimes employed for the torque or electrodynamic force produced by a magnetic field on an active conductor placed in it.

Draw-Bar.—In a locomotive, the link or bar which connects it with its load.

Draw-Bar Pull.—The pull delivered by a locomotive at its draw-bar, as distinguished from the pull exerted by its motor.

Drawbridge Frog.—A trolley frog for use at the point of overhead contact with a drawbridge wire.

Draw Tongs.—A species of vise employed in connection with a light block-and-tackle for obtaining the required tension on an aerial line wire.

Draw Vise.—(1) A device employed in stringing overhead wires. (2) A portable vise for holding and drawing up an overhead wire.

Drawing-In-and-Out Conduit.—A conduit provided with ducts, so as to readily permit the wires or conductors to be placed in the conduit or removed from after they have been placed therein.

Drawing-In Box.—A flush box.

Drifting of Needle.—(1) The failure of the needle of a galvanometer to remain at its zero point when no current is passing through its coils, due usually to variation in the condition of the magnetic needle, to variation in the torsion of the suspending system, or to local or other causes. (2) Elastic fatigue in the suspension of a magnetic system.

Drifting of Zero Point.—A term frequently employed for the shifting of the zero point.

Drilling, Electric.—(1) A term sometimes employed for the use of the voltaic arc in perforating a mass of metal or mineral. (2) Drilling by means of an electrically operated tool.

Drip Loop.—A loop inclined upwards at the point where outside conductors enter a building, so that the rain-water flows along said loop from the building, instead of towards it.

Driven Circuit of Transformer.—The secondary circuit of a transformer.

Driven Coil of a Transformer.—The secondary coil of a transformer.

Driven Pulley.—A pulley which receives its motion from a driving shaft.

Driven Pulley of Dynamo.—The pulley connected with the armature shaft of a dynamo.

Driven Shaft.—The shaft worked by a belt from the driving pulley.

Driving Circuit of Transformer.—The primary circuit of a transformer.

Driving Coil of a Transformer.—The primary coil of a transformer.

Driving Current of Motor.—The current which operates an electric motor.

Driving E. M. F.—The impressed or working E. M. F.

Driving Gear of Magneto.—The gear wheels connecting a magneto telephone-transmitter armature with the driving handle, whereby the speed of revolution of the armature is increased.

Driving Horns.—In a smooth-cored armature, mechanical projections for holding the armature wires in place, and communicating their electro-magnetic force to the armature.

Driving Pressure.—The driving or impressed E. M. F.

Driving Pulley.—That pulley of a machine which is mounted on the driving shaft.

Driving Pulley of Motor.—The pulley attached to the shaft of a motor, or the pulley through which a motor furnishes its mechanical power.

Driving Shaft.—The shaft connected directly with a prime mover.

Driving Spider.—The radial arms or spokes connected to the armature of a dynamo, and keyed to its shaft, so as to act as a driving wheel for the armature.

Drop.—(1) A word frequently used for drop of potential, pressure, or electromotive force. (2) The fall of potential which takes place in an active conductor by reason of its resistance.

Drop.—A shutter, or falling armature, of a drop annunciator.

Drop Annunciator.—An electro-magnetic annunciator, which, on being energized, releases a shutter and allows the same to drop.

Drop-Handle.—In single-needle telegraphy, a form of transmitter handle.

Drop Indicator.—A drop annunciator.

Drop of Magnetic Potential.—A fall of magnetic potential.

Drop of Potential.—The fall of potential, equal in any part of a circuit to the product of the current strength and the resistance of that part of the circuit.

Drop of Telephone Switchboard.—A small electro-magnetic annunciator inserted in the line of each subscriber,

whereby any current received from a subscriber attracts the armature of the electro-magnet and releases the shutter, thereby indicating the number of the particular subscriber calling.

Drop of Voltage.—The drop or difference of potential of any part of a circuit.

Drop Relay-Contact.—A form of relay-contact in which, on the passage of a current, the attraction of an armature releases a drop and thus completes a local circuit, which remains closed until the drop is reset.

Drop-Shutter of Annunciator.—The drop of an electro-magnetic annunciator.

Drop-Trolley.—A particular form of trolley wheel and pole which employs a swivel joint and springs forcing the trolley against the wire.

Drop-Trolley Stand.—A support for a trolley pole or mast provided with a swivel joint and suitable springs for ensuring a firm pressure of the trolley wheel against the trolley wire.

Drum.—A reel for holding wire or cable.

Drum Armature.—A dynamo armature whose coils are wound longitudinally over the surface of a cylinder or drum.

Drum Armature-Winding.—The winding employed on a drum armature.

Dry Battery.—(1) A number of separate dry voltaic cells, connected so as to act as a single source. (2) A dry pile.

Dry Cable.—A dry-core cable.

Dry Cell.—A dry voltaic cell.

Dry-Core Cable.—A cable whose core is wrapped with paper or cotton which is not afterwards filled with paraffine, gutta-percha, or other insulating material, and, consequently, whose dielectric consists largely of dry air.

Dry Distillation.—A species of destructive distillation.

Dry Electrode.—A therapeutic electrode applied in a dry state.

Dry Front of Microscopic Objective. That front of a microscopic object glass which is turned towards the object, but is separated from it by a short distance or air gap, in contradistinction to an immersion lens.

Dry Gelatine Cell.—A type of dry voltaic cell in which the fluid electrolyte is absorbed by, or combined with, a suitable gelatinous substance.

Dry Pile.—A dry battery.

Dry Transformer.—An air-insulated transformer, as distinguished from an oil-insulated transformer.

Dry Voltaic Cell.—(1) A misnomer for a voltaic cell in which the fluid electrolyte is held in suspension by saw-dust, gelatine, or other suitable material. (2) A sealed voltaic cell, which can, therefore, be inverted without danger of spilling liquid.

Dual Electrolysis.—A term sometimes employed to denote the double decomposition that attends the electrolysis of a metallic salt; viz. that of the salt and its solvent.

Dub's Laws.—A set of experimentally established laws relating to the tractive and attractive magnetic forces developed by electro-magnets under various conditions, of which the following are two:—"The attraction of V-shaped electro-magnets, with an equal number of windings, is proportional to the square of the magnetizing current strength." "The attraction of V-magnets is, with equal currents, proportional to the square of the number of windings of the magnetizing spirals."

Duct.—A space left in an underground conduit for a separate wire or cable.

Duct of Conduit.—The space provided in a conduit for a conductor or cable.

Dumb-Bell Vibrator.—An electric vibrator consisting of two spheres connected by a straight conductor containing an air-gap.

Dummy Moulding.—A moulding not intended for the reception of a wire, but as part of an ornamentation, the moulding being symmetrically arranged on the ceiling with an electrolier as a centre, with only one or a few of the mouldings actually having wires placed in them.

Duopod.—A two-legged screw support for a pendant or upright.

Duplex Balance.—The condition of a duplex telegraphic line, in which the home instruments are unaffected by the sending signals, and are, therefore, ready to respond to the received signals.

Duplex Cable.—A cable containing two separate conductors placed parallel to each other.

Duplex Circuit.—(1) A circuit arranged for duplex transmission. (2) A metallic circuit.

Duplex Cut-Out.—A cut-out so arranged that when one bar or strip is fused or melted by an abnormal current, another can be immediately substituted for it.

Duplex Electrolysis.—A term sometimes used for dual electrolysis.

Duplex Flat-Cable.—A flat laid-up cable containing two wires.

Duplex Loop.—A loop or pair of wires

- leading to a branch office, whereby a branch office can be brought into connection with a duplex set placed at the main office, for the duplex sending and reception of messages at said branch office.
- Duplex Telegraph.**—A general term embracing the apparatus employed in duplex telegraphy.
- Duplex Telegraphic Insulator.**—A double telegraph insulator.
- Duplex Telegraphy.**—A system of telegraphy whereby two messages can be simultaneously transmitted in opposite directions over a single wire.
- Duplex Telephony.**—Duplex telephonic transmission.
- Duplex Transmission.**—The sending of two telegraphic or telephonic messages simultaneously in opposite directions over the same wire.
- Duplex Wire.**—An insulated conductor containing two separate parallel wires.
- Duplex Working.**—Duplex transmission.
- Duplexed-Duplex Telephony or Telegraphy.**—Quadruplex telephony or telegraphy.
- Duplicate Arc.**—A multiple arc containing but two branches.
- Duration of Electric Discharge.**—The time required to effect a complete disruptive discharge.
- Dust Telephone-Transmitter.**—(1) A form of microphone transmitter in which finely granulated carbon or carbon dust is contained within a suitably shaped box, connected with the terminals of the transmitter. (2) A granular telephone transmitter.
- Dyad.**—(1) A chemical element which has two bonds by which it can unite or combine with other elements. (2) A bivalent element.
- Dyad Atom.**—An atom whose valency, atomicity, or combining power, is two.
- Dyeing, Electric.**—The application of electricity either to the reduction or to the oxidation of the salts used in dyeing.
- Dynamic Electricity.**—A term sometimes employed for current electricity, in contradistinction to static electricity. (Obsolete.)
- Dynamic Induction.**—(1) A term sometimes employed for mutual induction. (2) Kinetic induction.
- Dynamic Multiplier.**—(1) A term sometimes employed for a self-induction coil or a coil possessing self-induction. (2) A spark coil.
- Dynamic System of Induction Telegraphy.**—A term sometimes used for the current system of induction telegraphy, as distinguished from an electrostatic system of induction telegraphy.
- Dynamics.**—That branch of mechanics which treats of the action of a force in producing motions or pressures.
- Dynamo.**—A dynamo-electric machine or generator.
- Dynamo Armature-Coils.**—The coils employed on the armature of a dynamo-electric machine.
- Dynamo Balancing-Rheostat.**—An adjustable rheostat whose range is sufficient to balance the current of one dynamo against that of another, with which it is required to operate in parallel.
- Dynamo Battery.**—The combination of several separate dynamos to act as a single electric source.
- Dynamo Brush-Holders.**—Devices for supporting the collecting brushes of dynamo-electric machines.
- Dynamo Brush-Trimmer.**—A device for rapidly ensuring the accurate trimming of dynamo brushes.
- Dynamo Changing-Switch.**—A switch designed to throw a dynamo from one circuit to another.
- Dynamo-Electric Generator.**—A dynamo-electric machine.
- Dynamo-Electric Machine.**—(1) A machine for the conversion of mechanical energy into electric energy, by means of electro-dynamic induction. (2) A dynamo.
- Dynamo-Electric Machine Battery.**—A dynamo battery.
- Dynamo or Motor Frame.**—The iron body of a dynamo or motor, including the pole-pieces and standards, but excluding the base-plates and bearings.
- Dynamo or Motor Standards.**—The supports on which a dynamo or motor armature rests.
- Dynamo Pole-Changer.**—A pole-changing transmitter employed in a system of duplex or quadruplex telegraphy.
- Dynamo Power.**—The power of a motor to act as a generator.
- Dynamo Power of a Motor.**—(1) A power possessed by an electric motor of producing counter-electromotive force. (2) The number of volts of counter-electromotive force produced by a motor per revolution per-second.

- Dynamo Regulator.**—A name given to a form of rheostat employed in the regulation of a dynamo.
- Dynamo Resistance Box.**—A form of rheostat employed in the regulation of a dynamo.
- Dynamo Terminals.**—The main terminals of a dynamo.
- Dynamograph.**—A term sometimes applied to a typewriting telegraph that records the messages in typewritten characters, both at the receiving and transmitting ends of the line.
- Dynamograph, Electric.**—A device for electrically recording the work done by any machine.
- Dynamometer.**—A general name given to a variety of apparatus for measuring power.
- Dynamometric Governor.**—A dynamometer employed on the shaft of an

electric motor for the purpose of operating a regulating apparatus.

- Dynamotor.**—(1) A particular type of rotary transformer. (2) A motor-generator, in which a generator and motor armature-winding are rotated through a common magnetic field.
- Dynamotor Windings.**—Windings required for the armatures of the dynamo and motor of a dynamotor.
- Dyne.**—(1) The C. G. S. unit of force. (2) The force which in one second can impart a velocity of one centimetre-per-second to a mass of one gramme.
- Dyne-cm.**—An abbreviation proposed for a dyne-centimetre, the C. G. S. unit of work.
- Dyne: cm².**—An abbreviation proposed for a dyne-per-square-centimetre, the C. G. S. unit of pressure.
- Dyne-Centimetre-Per-Second.**—The C. G. S. unity of activity.

E

- E. or e.**—A symbol for electromotive force.
- E.**—A contraction sometimes used for earth.
- E. H. P.**—A contraction for electrical horse-power.
- E. M. F.**—A contraction for electromotive force.
- E. M. F. of Self-Induction.**—The E. M. F. generated in a loop of wire during the filling or emptying of that loop by magnetic flux from its own current.
- Ear.**—(1) A metal piece supported by an insulator to which the trolley wire is fastened. (2) A trolley ear.
- Ear Piece.**—A circular opening into an air chamber placed over the diaphragm of a telephone, suitably shaped to permit the ready application of the listener's ear.
- Earth.**—(1) A fault in a telegraphic or other line caused by the accidental contact of the line with the ground or earth, or with some other ground-connected conductor. (2) That part of the earth or ground which forms a part of an electric circuit.
- Earth-Battery Current.**—A current on a telegraph line caused by voltaic action between two dissimilar earth plates, as distinguished from a true earth current.
- Earth Cell.**—A term frequently applied to a variety of voltaic cell, consisting of any voltaic couple buried in a comparatively moist stratum of earth.
- Earth Circuit.**—A circuit in which the ground or earth forms part of the conducting path.
- Earth-Circuited Conductor.**—A conductor connected to the ground or to an earth-connected circuit.
- Earth Coil for Magnetic Measurement.**—A coil capable of being moved about a fixed axis, or fixed axes, employed for generating a measurable E. M. F. from the earth's magnetic field.
- Earth Connection.**—A conductor which establishes a connection between any apparatus or circuit and ground.
- Earth Currents.**—Electric currents flowing through the earth, caused by the difference of potential of its different parts.
- Earth Currents of Cable.**—Currents in a cable due to natural causes, such as climatic conditions or magnetic disturbances, as distinguished from the currents sent through the cable for the transmission of messages.
- Earthenware Conduit.**—A conduit, generally multiduct, made of glazed earthenware.

Earth-Grounded Wire.—A wire one terminal of which is grounded or put to earth, so that the earth forms a part of the circuit in which it is placed.

Earth Indicator.—An instrument suitable for the accurate determination of the magnetic inclination and the calibration of ballistic galvanometers.

Earth Overlap Test.—A localization test for the position of a partial earth in a telegraph line, conducted alternately by observers at each end of the line, the line being grounded at one end while its resistance is measured at the other, and resistance is added to one end until the fault is brought to the centre of the circuit.

Earth Plates.—Plates of metal, buried in the earth or in water, connected to the terminals of earth wires.

Earth Return.—That portion of a grounded circuit in which the earth forms its conducting path.

Earth Strip.—In a multiple telephone switchboard a strip of metal, or top plate of a series of jacks, permanently connected to earth through a battery, to furnish connections for the busy test.

Earth-Switch for Telephone.—(1) In a single-cord multiple telephone-switchboard, a device for maintaining a ground-connection with the shank of a plug when out of use, by supporting the plug, friction tight, against a ground-connected bar. (2) A switch at a telephone switchboard for automatically grounding the sleeve of a plug when out of use.

Earth Wires.—The wires that lead an earth-grounded circuit to the earth plates.

Earth's Field.—The magnetic field produced in any place by the earth's flux.

Earth's Flux.—The magnetic flux produced by the earth by virtue of its magnetized condition.

Earthed.—Connected to earth or ground.

Earthing.—Connecting a line or conductor to earth or ground.

Earthing Device.—An instrument for automatically making connection between a system of wiring and the earth, should the potential between them rise beyond a certain predetermined safe limit.

Earthkin.—A terella.

Easement.—A permit obtained from the owner of a property for the erection of poles or attachments for telephone, telegraph, or other aerial lines.

Ebonite.—(1) A hard, tough, black substance, composed of India rubber and

sulphur, possessing both high powers of insulation and high specific inductive capacity. (2) Vulcanite.

Economic Coefficient.—The ratio between the net electric power, or the output of a dynamo, and the gross electric power, or power actually converted in the dynamo.

Economic Coefficient of Dynamo-Electric Machine.—(1) The ratio between the electric power produced by a dynamo at its terminals, and the mechanical power expended in driving it. (2) A term sometimes employed for the ratio of the useful electric power at the terminals to the total electric power developed in the machine.

Economy Coil.—A choking coil employed for the purpose of reducing the pressure on arc lamps fed by step-down transformers.

Eddy Conduction-Currents.—(1) Eddy currents. (2) Foucault currents.

Eddy-Current Loss.—The loss of energy in a dynamo, motor, transformer, or similar apparatus, due to the presence of eddy currents.

Eddy Currents.—Useless currents produced in the pole-pieces, armature, and field-magnet cores of dynamos or motors, or in metallic masses generally, either by their motion through magnetic flux, or by variations in the strength of electric currents flowing near them.

Eddy Displacement-Currents.—Eddy currents produced in the mass of a dielectric or insulator, by the passage through it of electrostatic or magnetic flux.

Edgewise System.—A system of mounting central-station switchboard instruments, in which, for the purpose of economizing space, their scales are presented edgewise vertically to the switchboard face.

Edison Distributing-Box.—A distributing box employed in the Edison three-wire system of distribution.

Edison Effect.—An electric discharge which occurs between one of the terminals of the incandescent filament of an electric lamp and a metallic plate placed near but disconnected from the filament as soon as a certain difference of potential is reached between the lamp terminals.

Edison Electric-Tubes.—The underground tubes employed in the Edison three-wire system of distribution.

Edison-Lalande Cell.—A zinc-copper couple in which the copper is covered

with a depolarizing layer of copper-oxide, and the couple immersed in an electrolyte of caustic soda or potash.

Eel, Electric.—(1) An eel possessing the power of giving powerful electric shocks. (2) The *gymnotus electricus*.

Effective Ampere-Turns.—(1) The resultant magnetizing force in a magnetic circuit. (2) The square root of the mean square of the ampere-turns in a periodically-varying magnetizing force.

Effective Conductance.—(1) The ratio in an alternating-current circuit of the real electric power, or real activity, to the square of the effective pressure. (2) The virtual conductance of a circuit. (3) In an alternating-current circuit the ratio of the energy component of current to the total E. M. F.

Effective Current-Strength.—(1) The strength of an alternating or sinusoidal-electric current, determined by its heating effect; or, in other words, the thermally effective current strength. (2) That value of the current strength of a sinusoidal or alternating current which is equal to the square root of the mean square of the instantaneous values of the current during one or more cycles. (3) The square root of the time average of the square of the current.

Effective Electromotive Force.—(1) The difference between the direct and the counter-electromotive force. (2) The square root of the time average of the square of the E. M. F. (3) The virtual E. M. F.

Effective M. M. F.—The square root of the time average of the square of a periodically-alternating M. M. F.

Effective Reactance.—(1) In an alternating-current circuit, the ratio of the wattless component of an electromotive force to the total current. (2) Apparent reactance.

Effective Resistance.—In an alternating-current circuit, the ratio between the energy component of an electromotive force and the total current.

Effective Secondary-Electromotive Force.—(1) The vector difference between the direct and counter-electromotive force in the secondary of an induction coil. (2) The E. M. F. in a secondary circuit expended in overcoming resistance. (3) The square root of the time average of the square of a secondary E. M. F.

Effective Starting-Current of Motor.—The indicated value of the starting current of a motor as observed on an ammeter.

Effective Susceptance.—(1) In an alternating-current circuit, the ratio between the wattless component of a current and its total electromotive force. (2) Apparent susceptance.

Efficiency.—The ratio between an effect produced and the expenditure required to produce that effect.

Efficiency of Voltaic Battery.—(1) The ratio between the actual ampere-hour output per gramme of zinc dissolved, and the theoretical ampere-hour output. (2) The ratio of the energy delivered at the terminals of a battery to the theoretically computed energy liberated within it electrochemically. (3) The ratio of the energy at terminals to the total electric energy.

Efficient Value of Periodic Current or E. M. F.—(1) The square root of the mean square of the current or E. M. F. extended over one or more complete cycles. (2) The virtual current or E. M. F.

Efficiency, Electric.—The useful or available electric energy delivered by any source to its external circuit, divided by the total electrical energy within the source.

Efficiency of Dynamo, Electric.—The electrical output of a dynamo, divided by the total electric activity in its armature circuit.

Efficiency of Conversion.—The ratio between the energy present in any result and the energy expended in producing that result.

Efficiency of Conversion of Dynamo.—The total electric energy developed by a dynamo, divided by the total mechanical energy required to drive the dynamo.

Efficiency of Distribution.—The ratio of the units of electric quantity or electric energy sold, or distributed to consumers from a central station, to the units generated in that station.

Efficiency of Electric Lamp.—(1) The ratio of the luminous energy emitted by an incandescent lamp to the energy absorbed by the lamp. (2) The ratio of the number of candles which can be obtained from an electric lamp to the electric activity in the lamp expressed in watts. (3) A term in common but inaccurate use for the ratio of the number of watts consumed by a lamp to the number of candles it produces, expressed in watts per candle.

Efficiency of Electric Motor.—(1) The ratio of the power delivered at a motor pulley to the electric power supplied at its terminals. (2) The ratio between the useful mechanical power delivered by a

motor and the electrical power put in to drive it.

Efficiency of Radiation.—The ratio of the luminous activity of a luminous body to its radiation activity.

Efficiency of Secondary Battery.—(1) The ratio of the electric quantity of discharge in ampere-hours to the electric quantity in a charge. (2) The ratio of the electric energy of discharge in watt-hours to the electric energy of charge.

Efficiency of Transformer or Converter.—The ratio of the power supplied at the secondary terminals of a transformer or converter to the power supplied at its primary terminals.

Efflorescence.—(1) Pulverulence or crumbling of crystalline salts, due to the loss of their water of crystallization on drying. (2) A term loosely applied to the deposition of solid matter above the line of liquid on the surface of a vessel containing a vaporizing saline solution, by the crystallization of the salt.

Effluvia.—The name given to a variety of assumed highly tenuous imponderable forms of matter that were formerly believed to be given off by electrified or magnetized bodies.

Effluvium, Electric.—A term employed in the early history of electricity for the supposed highly-tenuous, imponderable matter given off from an electrified body, which was assumed to be the cause of electric phenomena.

Efflux.—The flow or quantity of liquid escaping in a given time from an orifice in a containing vessel.

Egg, Electric.—An egg-shaped vessel containing a partial vacuum through which an electric discharge is passed, for the purpose of producing luminous effects.

Elastance.—(1) The reciprocal of the electrostatic capacity. (2) The reciprocal of permittance.

Elastic.—(1) Of or pertaining to elasticity. (2) Possessing elasticity.

Elasticity.—That property of a body in virtue of which its original configuration or form is regained, after a strain or distortion has been produced in it by the action of a stress.

Elasticity, Electric.—The quotient arising from dividing the electric strain by the electric stress.

Elastivity.—The reciprocal of permittivity.

Elbow Connection.—A connection at an angle more or less approaching 90°.

Elbow Connector.—A connector suitable for connecting conductors at an elbow.

Electrepeter.—An old term for switch, key, or pole-changer. (Obsolete.)

Electret.—(1) A name proposed for a substance possessing natural or inherent electrization. (2) A permanently polarized body.

Electric.—Of or pertaining to electricity.

Electrical.—An orthography for electric.

Electrically.—In an electrical manner.

Electrically Conducting.—Transferring electricity by electric conduction.

Electrically Controlled Clock.—A clock that is controlled, either wholly or partially, by electricity.

Electrically Discharging.—Equalizing differences of potential by connecting them with a conductor.

Electrically Energizing.—Causing electricity to produce any effect in an electroreceptive device.

Electrically Illumined Buoy.—An electrically lighted buoy.

Electrically Retarded.—Decreased speed of telegraphic signalling by means of electrostatic induction.

Electrically Tuned System.—Any circuit or system of circuits that have been brought into electric resonance with another circuit or system of circuits.

Electrician.—One versed in the principles and applications of electricity.

Electricity.—The name given to the unknown cause of electric phenomena.

Electricity Driving-Force.—A term sometimes used for electromotive force.

Electricity Meter.—(1) A coulomb meter. (2) A term sometimes used for electric meter.

Electrics.—A term formerly applied to substances capable of becoming electrified by friction. (Obsolete.)

Electrifiable.—Capable of being endowed with electric properties.

Electrification.—The production of an electric charge.

Electrified.—Endowed with an electric charge.

Electrified Body.—A charged body.

Electrify.—To endow with electric properties.

Electrine.—Of or pertaining to electrum or amber.

- Electripherous.**—An unnecessary word proposed for anything capable of bearing or transmitting electricity.
- Electrization.**—Electrification.
- Electrize.**—To electrify or endow with an electric charge.
- Electrizer.**—Anything which electrifies or charges a body with electricity.
- Electro - Anæsthesia.**—Insensibility to pain produced by the use of electricity.
- Electro-Ballistics.**—The application of electricity to the determination of the velocity of projectiles.
- Electro-Bath.**—The liquid or fluid employed in electro-plating.
- Electro-Biological.**—Pertaining to electro-biology.
- Electro-Biologist.**—One skilled in electro-biology.
- Electro-Biology.**—That branch of electric science which treats of the condition of living animals and the effects of electricity upon them.
- Electro-Bioscopist.**—One skilled in electro-bioscopy.
- Electro-Bioscopy.**—The determination of the existence of life or death by the passage of electricity through the muscles and nerves.
- Electro-Brassing.**—(1) The electrolytic deposition of brass from a solution containing salts of zinc and copper. (2) Coating a surface with a layer of brass by electro-plating.
- Electro-Calorimetry.**—The art of measuring the quantity of heat developed in any conductor or circuit by an electric current.
- Electro-Capillarity.**—The science which treats of the mutual effects between electricity and capillarity.
- Electro-Capillary.**—Of or pertaining to electro-capillarity.
- Electro - Capillary Electrometer.**—A capillary electrometer.
- Electro-Capillary Light.**—A bright light obtained by the discharge of an induction coil through a narrow capillary tube provided with aluminium or copper electrodes, and filled with air at ordinary pressures.
- Electro-Capillary Phenomena.**—Electric phenomena observed in capillary tubes at the contact surfaces of two liquids.
- Electro-Capillary Telephone.**—A telephone transmitter whose operation depends on the electric currents produced by forcing a liquid through a bundle of capillary tubes, by the to-and-fro movements of the diaphragm.
- Electro-Chemical.**—Of or pertaining to electro-chemistry.
- Electro-Chemical Accumulator.**—A storage battery.
- Electro-Chemical Actinometer.**—(1) An actinometer employing electrolytic action. (2) An electric actinometer.
- Electro-Chemical Decomposition.**—Electrolytic decomposition.
- Electro-Chemical Filtration.**—A term formerly employed in place of electric endosmose.
- Electro-Chemical Meter.**—An electric meter in which the current passing is measured by the amount of electrolytic decomposition it effects.
- Electro-Chemical Telephone.**—A name sometimes given to the Edison electromotographic telephone.
- Electro-Chemical Series.**—A list of chemical elements so arranged that each will displace from its compounds any element lower in the list than itself.
- Electro - Chemically.**—In an electro-chemical manner.
- Electro - Chemist.**—One skilled in the science of electro-chemistry.
- Electro-Chemistry.**—(1) That branch of electric science which treats of electric combinations and decompositions effected by the electric current. (2) The science which treats of the relation between the laws of electricity and chemistry.
- Electro-Chromic Rings.**—(1) A term sometimes applied to metallochromes. (2) Nobilli's rings.
- Electro-Chronographic.**—Of or pertaining to the electric chronograph.
- Electro-Chronometric Counter.**—An apparatus employed in a system of electric clocks to enable the master clock electrically to control or operate a number of separate or secondary clocks.
- Electro - Coppering.**— Electro - plating with copper.
- Electro-Crystallization.**—Crystallization effected during electrolytic deposition.
- Electro-Culture of Plants.**—Stimulating the growth of plants by electricity.
- Electro-Deposit.**—A coating or electro-plating of metal.
- Electro-Depositer.**—One who practises the art of electro-deposition.
- Electro - Deposition.**—(1) The deposit, usually of a metallic substance, by means

- of electrolysis. (2) Electrolytic deposition.
- Electro-Deposits.**—Electrolytic deposits.
- Electro-Diagnosis.**—Diagnosis by means of the exaggeration or diminution of the reaction of the excitable tissues of the body when subjected to the varying influences of electric currents.
- Electro-Diagnostic.**—Of or pertaining to electro-diagnosis.
- Electro-Diapason.**—An electro-magnetically operated tuning-fork.
- Electro-Dynamic Attraction.**—The mutual attraction existing between electric currents, or between conductors through which electric currents are passing.
- Electro-Dynamic Balance.**—A balance form of electro-dynamometer.
- Electro-Dynamic Capacity.**—A term sometimes employed for self-induction.
- Electro-Dynamic Force.**—A mechanical force exerted on the substance of a wire or conductor due to the dissymmetrical distribution of magnetic flux in its neighborhood.
- Electro-Dynamic Induction.**—Electromotive forces set up by induction in conductors which are either actually or practically moved so as to cut magnetic flux.
- Electro-Dynamic Interrupter.**—An interrupter for the primary circuit of an induction coil, consisting of an elastic wire stretched, like the wire of a sonometer or monochord, between the poles of a permanent horse-shoe magnet.
- Electro-Dynamic Machinery.**—Any apparatus designed for the production, transference, utilization, or measurement of energy by the medium of electricity.
- Electro-Dynamic Motor.**—(1) A motor operated by electro-dynamic force. (2) An electric motor.
- Electro-Dynamic Potential.**—An electric potential produced by electro-dynamic induction.
- Electro-Dynamic Repulsion.**—The mutual repulsion between two electric circuits whose currents are flowing in opposite directions.
- Electro-Dynamic Rotation.**—(1) The rotation of a magnetic field produced as the resultant of two or more magnetic fields or magnetizing forces of variable intensity, acting at right angles to one another, whose maxima and minima do not coincide, but whose periods are the same. (2) Rotation produced electro-dynamically.
- Electro-Dynamic Screen.**—A conducting screen employed for intercepting the transmission of varying electro-magnetic forces.
- Electro-Dynamic Whirls.**—Whirlings, or rotary motions produced in a cloud of copper oxide in a voltameter, when the electrolyte is traversed by a powerful discharge, while under the influence of magnetic flux.
- Electro-Dynamics.**—That branch of electric science which treats of the action of electric currents on one another, on themselves, or on magnets.
- Electro-Dynamical.**—Of or pertaining to electro-dynamics.
- Electro-Dynamometer.**—A form of galvanometer suitable for the measurement of electric currents.
- Electro-Dynamometer Balance.**—A name sometimes given to a current balance.
- Electro-Etching.**—A term sometimes employed for electric engraving.
- Electro-Extraction of Ores.**—Various electric processes for extracting metals from their ores.
- Electro-Filtration.**—A term sometimes employed for electric osmose or cataphoresis.
- Electro-Genesis.**—A word proposed for the production of electricity. (Not in use.)
- Electro-Genic.**—Producing electricity. (Not in use.)
- Electro-Gild.**—To cover with a metallic coating of gold by electro-plating.
- Electro-Gilder.**—One who practises the art of electro-gilding.
- Electro-Gilding.**—(1) Electric gilding. (2) Electro-plating with gold.
- Electro-Gilt.**—Gilded by means of electricity.
- Electro-Graphy.**—Galvanography.
- Electro-Inductive Repulsion.**—Repulsion between bodies due either to the influence of electrostatically induced charges, or electromagnetically induced currents.
- Electro-Kinetic.**—Of or pertaining to electro-kinetics.
- Electro-Kinetic Energy.**—Electrical energy that is actually engaged in doing work.
- Electro-Kinetic Units.**—A term sometimes used for C. G. S. electro-magnetic units.
- Electro-Kinetics.**—A term sometimes applied to the phenomena of electric currents, or electricity in motion, as dis-

tinguished from electrostatics, or the phenomena of electric charges, or electricity at rest.

Electro-Lithotrity.—A term proposed for the removal of urinary calculi by electrolysis.

Electro-Magnet.—(1) A magnet produced by the passage of an electric current through a circuit of insulated wire. (2) A magnetizing coil surrounding a soft iron core, that is capable of being magnetized and demagnetized instantly on the closing and opening of the circuit.

Electro-Magnetic.—Of or pertaining to an electro-magnet or to electro-magnetism.

Electro-Magnetic Ammeter.—A form of ammeter in which a magnetic needle is moved against the field of an electro-magnet by the field of the current it is measuring.

Electro-Magnetic Annunciator.—An electro-magnetic device for automatically indicating the points or places at which one or more electric contacts have been closed.

Electro-Magnetic Attraction.—The mutual attraction existing between the unlike poles of electro-magnets.

Electro-Magnetic Bell.—An electro-magnetically operated bell.

Electro-Magnetic Bell-Call.—A bell-call operated by an electro-magnet.

Electro-Magnetic Brake.—A brake for car wheels, whose braking power is either entirely derived from electro-magnetism, or is thrown into action by electro-magnetic devices.

Electro-Magnetic Cam.—A form of magnetic equalizer which depends for its operation on the lateral approach of a suitably shaped polar surface.

Electro-Magnetic Capacity of Line.—A term sometimes used for the self-induction or inductance of a line.

Electro-Magnetic Cut-Out.—A cut-out operated by means of an electro-magnet.

Electro-Magnetic Dental Mallet.—A mallet for filling teeth, the blows of which are struck by means of an electro-magnetically driven mechanism.

Electro-Magnetic Drill.—A drum employed in blasting and mining operations, operated by means of electricity.

Electro-Magnetic Drum.—A drum used in feats of legerdemain operated by means of an automatic electro-magnetic contact-breaker.

Electro-Magnetic Engine.—An electric motor.

Electro-Magnetic Explorer.—An apparatus operated by means of induced currents, and formerly employed for the purpose of locating bullets, or other foreign metallic substances in the human body.

Electro-Magnetic Eye.—(1) A term applied to a certain form of spark micrometer, employed by Hertz in his experiments on electro-magnetic radiation. (2) A term sometimes applied to a coherer.

Electro-Magnetic Field.—The field produced either by an electro-magnet or by an electric current.

Electro-Magnetic Flux.—Magnetic flux produced by means of an electro-magnet or by an electric current.

Electro-Magnetic Gyroscope.—An electro-magnetically driven gyroscope.

Electro-Magnetic Helix.—An electro-magnetic solenoid.

Electro-Magnetic Impulse.—An impulse produced in the ether surrounding a conductor by the action of an impulsive discharge, or by a pulsating field.

Electro-Magnetic Induction.—A variety of electro-dynamic induction in which electric currents are produced by the motion either of electro-magnets, or electro-magnetic solenoids.

Electro-Magnetic Inertia.—A term sometimes employed for the inductance or self-induction of a current.

Electro-Magnetic Interference.—The interference of electro-magnetic waves.

Electro-Magnetic Intermittent.—An electro-magnetic vibrator.

Electro-Magnetic Medium.—Any medium in which electro-magnetic phenomena occur, or through which electro-magnetic waves are transmitted.

Electro-Magnetic Meter.—An electric meter in which the current passing is measured by the electro-magnetic effects it produces.

Electro-Magnetic Mine-Exploder.—A small magneto-electric machine employed in the direct firing of blasts.

Electro-Magnetic Momentum.—The product of the inductance of a circuit and the current strength it carries.

Electro-Magnetic Motor.—An electric motor.

Electro-Magnetic Multiplier.—A term sometimes employed for Schweigger's multiplier.

Electro-Magnetic Optical-Strain.—Any optical strain produced by electro-magnetic stress.

Electro-Magnetic Pop-Gun.—A magnetizing coil, provided with a tubular space for the insertion of a core much shorter than the length of the coil, which is violently projected when the coil is energized by a current.

Electro-Magnetic Radiation.—The radiation, from any conductor through which oscillatory discharges are passing, of electro-magnetic waves similar in all respects to those of light, save in their much greater wave length.

Electro-Magnetic Repeater.—A word formerly employed for a form of vibrating contact-breaker.

Electro-Magnetic Repulsion.—The mutual repulsion produced by two similar electro-magnetic poles.

Electro-Magnetic Resonator.—A term sometimes applied to a Hertz spark micrometer, in which electro-magnetic waves are produced by electric resonance.

Electro-Magnetic Retardation.—A retardation in the magnetization or demagnetization of a substance.

Electro-Magnetic Rotation.—Rotation obtained by electro-magnetic attractions and repulsions.

Electro-Magnetic Separator.—(1) A device for separating iron ore from the dross, in finely-pulverized, low-grade iron ores. (2) A device for magnetically removing particles of iron from brass filings or other non-magnetic material, and thus freeing such material from impurities.

Electro-Magnetic Shunt.—(1) In a system of telegraphic communication, an electro-magnet whose coils are placed in a shunt circuit around the terminals of the receiving instrument. (2) Any shunt coil provided with a magnetic core.

Electro-Magnetic Solenoid.—(1) A cylindrical coil of wire, each convolution of which is circular. (2) An electro-magnetic helix. (3) A cylindrical current sheet.

Electro-Magnetic Sorter.—An electro-magnetic separator.

Electro-Magnetic Strain.—The effect produced by an electro-magnetic stress.

Electro-Magnetic Stress.—The force or pressure in an electro-magnetic field which produces a strain or deformation in a piece of glass or other substance placed therein.

Electro-Magnetic Telegraph.—A general term embracing the apparatus employed in a system of electro-magnetic telegraphy.

Electro-Magnetic Telegraphy.—(1) A system of telegraphy employing or based upon electro-magnetism. (2) The ordinary Morse telegraphy.

Electro-Magnetic Temperature-Regulator.—A temperature regulator whose operation is dependent on the action of an electro-magnet which is thrown into operation by the expansion or contraction of a solid liquid or gas.

Electro-Magnetic Twist or Pull.—The torque of an electro-magnetic motor.

Electro-Magnetic Units.—(1) A system of C. G. S. units employed in electro-magnetic measurements. (2) Units based on the attractions and repulsions capable of being exerted between two unit magnetic poles at unit distance apart, or between a unit magnetic pole and a unit electric current.

Electro-Magnetic Vibrator.—A name sometimes given to an automatic contact-breaker.

Electro-Magnetic Waves.—Waves in the ether, given off from a circuit through which an oscillatory discharge is passing, or from a magnetic circuit undergoing variations of magnetic intensity.

Electro-Magnetic Voltmeter.—A form of voltmeter in which the difference of potential is measured by the movements of a magnetic needle in the field of an electro-magnet.

Electro-Magnetics.—That branch of electric science which treats of the relations that exist between electric circuits and magnets.

Electro - Magnetism.—Magnetism produced by means of electric currents.

Electro-Magnetist.—One skilled in the art of electro-magnetism. (Not in use.)

Electro - Massage.—The application of electricity to the body during its massage.

Electro-Mechanical Alarm.—A mechanically operated alarm, that is started or set in operation by means of an electric current.

Electro-Mechanical Bell.—A bell whose striking apparatus is mechanically operated, when called into action by an electro-magnet.

Electro - Mechanical Gong.—A gong struck or operated by mechanical force, at times which are dependent on the passage of an electric current.

- Electro-Mechanical Indicator.**—A mechanical indicator that is started or set into action by electricity.
- Electro-Medical.**—Of or pertaining to electricity employed electro-therapeutically.
- Electro-Medical Apparatus.**—A general term for any apparatus employed in electro-therapeutic treatment.
- Electro-Metallurgical Circuit.**—An electric circuit employed in electro-metallurgical processes.
- Electro-Metallurgical Galvanization.** A process of covering any conducting surface with a metallic coating by electrolytic deposition, such, for example, as the thin copper coating deposited on the carbon electrodes used in arc-lights.
- Electro-Metallurgical Deposit.**—A metallic deposit thrown down on a conducting surface by electrolysis.
- Electro-Metallurgical Dipping.**—A process for obtaining an electro-metallurgical deposit on a metallic surface by dipping it in a solution of a readily decomposable metallic salt.
- Electro-Metallurgical Galvanization.** The electro-therapeutic effects produced on nerves or muscles by the passage of an electric current.
- Electro-Metallurgy.**—(1) That branch of electric science which relates to the electric reduction or treatment of metals. (2) Electro-metallurgical processes effected by the agency of electricity. (3) Electroplating or electro-typing.
- Electro-Motion.**—Motion produced by electricity.
- Electro-Motor.**—A term sometimes employed for a voltaic couple.
- Electro-Muscular.**—Of or pertaining to the influence of electricity on the muscles.
- Electro-Muscular Excitation.**—In electro-therapeutics, the galvanic or faradic excitation of a muscle, or its excitation by the continuous current from a voltaic battery, or by the alternating currents from an induction coil.
- Electro-Negative.**—(1) In such a state as regards electricity as to be repelled by bodies negatively electrified, and attracted by those positively electrified. (2) The ions or radicals which appear at the anode or positive electrode of a decomposition cell.
- Electro-Negative Ions.**—(1) The negative ions, or groups of atoms or radicals, which appear at the anode or positive terminal of a decomposition cell. (2) The anions.
- Electro-Negative Radicals.**—The electro-negative ions.
- Electro-Negatively.**—In an electro-negative manner.
- Electro-Negatives.**—(1) The anions or electro-negative ions of a radical. (2) The atoms or radicals that appear at the anode, or positive terminal of any source, during electrolysis.
- Electro-Nervous Excitability.**—The electro-therapeutic excitation of a nerve.
- Electro-Nickeling.**—Electroplating with nickel.
- Electro-Optics.**—That branch of science which treats of the general relations existing between light and electricity.
- Electro-Pathic.**—Of or pertaining to electro-pathology.
- Electro-Pathology.**—Diagnosis by means of electricity.
- Electro-Percussion Drill.**—(1) A drill employed for quarrying or mining in which a reciprocating motion for the drill is obtained by sending an electric current alternately through one or the other of a pair of solenoids of which the drill stock forms the core. (2) Any reciprocating drill operated electrically.
- Electro-Photometer.**—An instrument for measuring the intensity of light by means of electricity.
- Electro-Photo-Micography.**—Photography of the magnified images of microscopic objects illumined by the electric light.
- Electro-Physiological.**—Of or pertaining to electro-physiology.
- Electro-Physiologist.**—One skilled in electro-physiology.
- Electro-Physiology.**—The study of electric phenomena of living animals and plants.
- Electro-Plating.**—The process of covering any conducting surface with a metal, by the aid of an electric current.
- Electro-Plating Bath.**—A tank containing a metallic solution in which articles are placed to be electro-plated.
- Electro-Pneumatic.**—Of or pertaining to the combined action of electricity and air pressure.
- Electro-Pneumatic Block System.**—A block system for railroads in which the semaphores are operated pneumatically under the control of electro-magnetically operated valves.
- Electro-Pneumatic Signals.**—Signals operated by diaphragms or pistons.

moved by compressed air, under electric control.

Electro-Pneumatic Thermostat.—An instrument for automatically indicating the existence of a given temperature by the closing of an electric circuit, on the expansion or contraction of a gas.

Electro-Polar.—Possessing electric poles.

Electro-Positive.—(1) In such a state, as regards an electric charge, as to be attracted by a body negatively electrified, and repelled by a body positively electrified. (2) The ions or radicals which appear at the cathode or negative electrode of a decomposition cell.

Electro-Positive Ions.—The cations or groups of atoms or radicals which appear at the cathode of a decomposition cell.

Electro-Positively.—In an electro-positive manner.

Electro-Positives.—(1) The cations or electro-positive ions of radicals. (2) The atoms or radicals that appear during electrolysis at the cathode, or negative electrode.

Electro-Positive Radicals.—The electro-positive ions.

Electro-Potential Energy.—Electric energy possessing the power of doing work, but not actually doing work.

Electro-Prognosis.—In electro-therapeutics a prognosis, or prediction of the fatal or non-fatal termination of a disease, from an electro-diagnosis based on the exaggerated or diminished reactions of the excitable tissues of the body, when subjected to the varying influences of electric currents.

Electro-Puncturation.—Electro-puncture.

Electro-Puncture.—The application of electrolysis to the treatment of aneurisms or diseased growths.

Electro-Pyrometer.—An apparatus for the determination of temperature by the measurement of the electric resistance of a platinum wire exposed to the temperature which is to be measured.

Electro-Receptive Devices.—(1) Various devices suitable for being placed in an electric circuit and energized by the passage of an electric current through them. (2) Translating devices.

Electro-Reciprocating Drill.—An electro-percussion drill.

Electro-Refining.—Various processes for the electric refining of metals.

Electro-Skiagraph.—A term proposed for a radiograph or X-ray picture.

Electro-Semaphore.—A semaphore operated by means of electricity.

Electro-Sensibility.—An effect produced on a sensory nerve by its electrization.

Electro-Siliceous Light.—An effect obtained by the discharge of a powerful rheostatic machine, through a glass tube traversed by a platinum wire, and plunged in salt water, the heat of the discharge not only melting and volatilizing the wire, but also raising the glass tube to brilliant incandescence.

Electro-Silvering.—Covering a surface with an adherent coating of silver, by electro-plating.

Electro-Smelting.—The separation or reduction of metallic substances from their ores, by means of the heat developed by electric currents.

Electro-Statics.—That branch of electric science which treats of the phenomena and measurement of electric charges.

Electro-Steeling.—(1) The art of covering copper electrodes with a thin coating of hardened iron. (2) Covering a printing surface of an electro with a thin deposit of copper, for the purpose of hardening it.

Electro-Stereotype.—A word sometimes employed for electro-type.

Electro-Stereotyping.—Electro-typing.

Electro-Synthesis.—The chemical combination of electro-positive and electro-negative radicals under the influence of electricity.

Electro-Technics.—The science which treats of the technical applications of electricity and the general principles involved therein.

Electro-Telegraphy.—Electric telegraphy.

Electro-Therapeutic Bath.—A bath furnished with suitable electrodes for use in the therapeutic applications of electricity.

Electro-Therapeutic Breeze.—An electric breeze or convection current in air produced by the electrification of metallic points.

Electro-Therapeutic Diffusion of Current.—The difference in the density of a current in different parts of the human body between electrodes applied therapeutically.

Electro-Therapeutic Dosage.—Proportioning the strength of an electro-therapeutic current and the duration of its application to the body.

Electro-Therapeutic Electrode.—The electrode mainly concerned in the electro-

- therapeutic treatment or diagnosis of diseased or disordered parts of the body.
- Electro-Therapeutic Electrodes.**—Electrodes of various shapes employed in electro-therapeutics.
- Electro-Therapeutic Galvanization.**—In electro-therapeutics, the effects produced on nervous or muscular tissue by the passage of a voltaic current.
- Electro-Therapeutic Head-Breeze.**—A form of electric breeze or convective electric discharge applied to the head.
- Electro-Therapeutic Polarizing-Current.**—The current which produces the phenomena of electro-tonus.
- Electro-Therapeutic Electrician.**—An electro-therapist.
- Electro-Therapeutics.**—(1) The application of electricity to the human body for the curing of disease or the improvement of health. (2) Electro-therapy.
- Electro-Therapeutist.**—An electro-therapist.
- Electro-Therapist.**—(1) One skilled in electro-therapy. (2) An electro-medical practitioner.
- Electro-Therapy.**—A word sometimes used instead of electro-therapeutics.
- Electro-Thermal Meter.**—An electric meter in which the current is measured by means of the heat generated by the passage of the current through a resistance.
- Electro-Thermancy.**—That branch of electricity which treats of the effects produced by an electric current on the temperature of a thermo-electric junction.
- Electro-Thermic.**—Of or pertaining to the generation of heat by means of electricity.
- Electro-Thermic Lightning-Arrester.**—A lightning arrester operated by the expansion of a high-resistance shunt wire permanently connected to the circuit.
- Electro-Thermotic.**—Of or pertaining to heat generated by electricity.
- Electro-Tinning.**—Covering a substance with a coating of tin by electro-plating.
- Electro-Tint.**—An etching obtained by electricity.
- Electro-Tinting.**—A term proposed for a method of electric engraving.
- Electro-Type.**—To produce a fac-simile by electrolytically depositing metals in a mould.
- Electro-Type.**—A cast or impression of type obtained by means of electro-metallurgy.
- Electro-Type Process.**—The process of electro-typing.
- Electro-Typic.**—Of or pertaining to electro-typy.
- Electro-Typing.**—Obtaining casts or copies of pages of type by depositing metals in moulds, by the agency of electric currents.
- Electro-Typographic.**—Pertaining to printing by means of electricity.
- Electro-Typy.**—The art of producing electro-types.
- Electro-Vection.**—A term sometimes employed for electric endosmose.
- Electro-Vital.**—Pertaining to the relations between electricity and vitality.
- Electrocrosis.**—A word proposed for curing disease by electricity. (Not used.)
- Electro Compound-Magnet.**—A term formerly applied to an electro-magnet whose core was wound with two separate wires or conductors. (Obsolete.)
- Electro Contact-Mine.**—A submarine mine that is automatically fired on the completion of the current of a battery placed on shore, on the closing of floating contact points by passing vessels.
- Electrocution.**—Capital punishment by means of electricity.
- Electrode.**—(1) Either of the terminals of an electric source. (2) Either of the terminals of an electric source that are placed in a solution in which electrolysis is taking place. (3) Either of the electro-therapeutic terminals of an electric source.
- Electrodes.**—The positive and negative terminals of an electric source, at their points of application to a receptive device.
- Electrodeless Discharge.**—The discharge obtained through the rarified gas of any vacuum tube that is unprovided with electrodes.
- Electrogen.**—A name sometimes applied to the unknown cause of electricity. (Not in general use.)
- Electrograph.**—(1) A curve produced by a recording electrometer. (2) A word sometimes used for radiograph.
- Electrographics.**—(1) The science of geometrically solving electrical problems by graphical methods. (2) The science which treats of the graphical representation of electric quantities.

- Electrolier.**—A chandelier for holding electric lamps, as distinguished from a chandelier for holding gas burners.
- Electrolier Arm.**—An electric fixture employed for attaching incandescent electric lamps to gas fixtures or electroliers.
- Electrolier Cut-Out.**—Any cut-out connected in the circuit of an electrolier.
- Electrolier Switch.**—A switch conveniently located for lighting or extinguishing lamps in an electrolier.
- Electrization.**—The act of being electrified, or electrifying.
- Electrologist.**—An unnecessary word proposed for electrician.
- Electrologist.**—One skilled in the science of electricity. (Not in general use.)
- Electrology.**—That branch of science which treats of electricity. (Obsolete.)
- Electrolysis.**—(1) Chemical decomposition effected by means of an electric current. (2) The decomposition of the molecule of an electrolyte into its ions or radicals. (3) Electrolytic decomposition.
- Electrolysis by Means of Alternating Currents.**—Electrolytic decomposition effected, under certain circumstances, by alternating currents.
- Electrolysis of Salts.**—The electrolytic decomposition of a salt into its constituent ions or radicals.
- Electrolyte.**—(1) Any compound liquid which is separable into its constituent ions or radicals by the passage of electricity through it. (2) The exciting liquid in a voltaic cell.
- Electrolytic.**—Of or pertaining to electrolysis.
- Electrolytic Accumulator.**—A word sometimes applied to a secondary or storage battery.
- Electrolytic Analysis.**—A term sometimes used for electric analysis.
- Electrolytic Annunciator.**—An annunciator consisting of a number of separate electrolytic cells, provided with a transparent cover, and so arranged that on the closing of the circuit of any particular cell by a distant push-button, a chemical decomposition is effected in the liquid of the electrolytic cell and a reddish-brown film formed over the surface of the electrode connected therewith.
- Electrolytic Assaying.**—Assaying by means of electrolysis.
- Electrolytic Bath.**—An electrolytic cell.
- Electrolytic Cell.**—(1) A cell or vessel containing an electrolyte in which electrolysis is carried on. (2) A plating cell or vat.
- Electrolytic Clock.**—A timepiece in which the rotation of the clock-work is obtained by the rotation of a delicately pivoted and well balanced wheel by the difference in weight of its two halves immersed in an electrolytic bath, on the passage of an electrolyzing current.
- Electrolytic Condenser.**—A condenser consisting of a number of iron plates immersed in a solution of carbonate of soda, and inserted in a branch circuit for the purpose of giving the current in that circuit a lead, by increasing the capacity.
- Electrolytic Conduction.**—A term sometimes employed to indicate the passage of electricity through an electrolyte by means of charges imparted to its free ions or radicals.
- Electrolytic Conductivity.**—The reciprocal of the electrolytic resistance.
- Electrolytic Convection.**—A term proposed for explaining the apparent conduction of electricity by an electrolyte, without decomposition.
- Electrolytic Corrosion.**—The corrosion by electrolytic action of water-pipes, gas-pipes, or other masses of metal, buried in moist earth.
- Electrolytic Coulomb-Meter.**—A coulomb-meter whose operation depends on electrolytic decomposition.
- Electrolytic Diaphragm.**—A diaphragm in an electro-plating bath.
- Electrolytic Decomposition.**—The separation of a molecule into its constituent ions or radicals by the action of an electric current.
- Electrolytic Dissociation.**—Electrolytic decomposition.
- Electrolytic Epilation.**—The removal of hair by electrolysis.
- Electrolytic Etching.**—(1) Etching by means of electrolytic corrosion. (2) A form of electric etching.
- Electrolytic Exchange.**—Electrolysis.
- Electrolytic Generator.**—A continuous-current dynamo-electric generator designed for supplying electricity for electrolytic purposes.
- Electrolytic Heating.**—A method of electric heating consisting in plunging the metal to be heated beneath the surface of a conducting liquid, while held in a metal clamp that is connected to the negative pole of a continuous-current source, while the positive pole of such source is connected to the metal lining of the vessel containing the conducting liquid.

- Electrolytic Hydrogen.**—Electrolytically liberated hydrogen.
- Electrolytic Meter.**—An electro-chemical meter.
- Electrolytic Moulding.**—A term sometimes employed for electro-typing.
- Electrolytic Refining.**—The refining of metals by electrolysis.
- Electrolytic Removal of Hair.**—Electrolytic epilation.
- Electrolytic Separation.**—Molecular dissociation produced by electrolysis.
- Electrolytic Synthesis.**—Synthesis of a substance by electrolytic means.
- Electrolytic Writing.**—Imprinting written characters on cloths or other textile fabrics by the electrolytic decomposition of a dyeing substance with which they are impregnated.
- Electrolytically.**—In an electrolytic manner.
- Electrolyzability.**—Possessing the power of being electrolyzed.
- Electrolyzable.**—Capable of being electrolyzed or decomposed by means of electricity.
- Electrolyzation.**—The act of electrolyzing.
- Electrolyze.**—To separate or decompose by means of electricity.
- Electrolyzed.**—Separated or decomposed by means of electricity.
- Electrolyzer.**—(1) One who, or that which, causes electrolysis. (2) An electrolyzing apparatus.
- Electrolyzing.**—Causing or producing electrolysis.
- Electrolyzing Cell.**—An electrolytic cell.
- Electrolyzing Chamber.**—A chamber or space in which electrolysis occurs.
- Electrometer.**—An apparatus for measuring differences of electric potential.
- Electrometer Fatigue.**—The failure of the needle of an electrometer to return to the zero point, due to the elastic fatigue of its suspension.
- Electrometer Gauge.**—A device employed in connection with some heterostatic electrometers, to ascertain whether the needle connected with the layer of acid, that acts as the inner coating of a Leyden-jar used in connection therewith, is at its normal potential.
- Electrometer-Voltmeter.**—A voltmeter in which the differences of potential to be measured are employed to charge insulated conductors, the electrostatic attractions and repulsions of which result in the deflection of a suitably suspended metallic needle.
- Electrometric.**—Of or pertaining to an electrometer.
- Electrometrical.**—(1) Of or pertaining to the measuring of electrical forces. (2) Of or pertaining to an electrometer.
- Electromotive Arrangement or Device.**—An electromotive source.
- Electromotive Force.**—(1) The force which starts or tends to start electricity in motion. (2) The maximum or total generated difference of potential which exists in a circuit.
- Electromotive Force of Induction.**—The electromotive force developed by any inductive action.
- Electromotive Impulse.**—An impulse producing an impulsive rush of electricity.
- Electromotive Intensity.**—The vector electric force at a point, as measurable by the mechanical force that would be exerted upon a unit electric charge at that point.
- Electromotive Series.**—A name sometimes given to a contact series.
- Electromotive Source.**—Any source such as a dynamo, or voltaic cell, capable of producing an electromotive force.
- Electromotograph.**—An apparatus in which the friction of a platinum point against a rotating cylinder of chalk is reduced by electrolytic action, consequent on the passage of an electric current.
- Electromotographic Telephone.**—A loud-speaking telephone operating on the principle of the electromotograph.
- Electron.**—(1) A word formerly used for amber. (2) The electric atoms whose projection from the cathode of a high-vacuum tube is supposed to constitute the cathode rays or streamings. (3) An alloy of gold and silver.
- Electronecrosis.**—Pertaining to capital punishment by means of electricity.
- Electronecrosis.**—A word proposed for capital punishment by means of electricity. (Not in use.)
- Electronome.**—A name proposed for a measurer of electricity. (Not in use.)
- Electropath.**—One skilled in the art of electro-therapy.
- Electropathy.**—A word sometimes employed for electro-therapeutics.
- Electrophanic.**—Pertaining to capital punishment by means of electricity.

- Electrophanical.**—Pertaining to capital punishment by means of electricity.
- Electrophanize.**—To inflict capital punishment by means of electricity.
- Electrophany.**—A word proposed for capital punishment by means of electricity. (Not in use.)
- Electrophila.**—A word proposed for capital punishment by means of electricity. (Not in use.)
- Electrophobia.**—A word proposed for unnecessary fear of electricity.
- Electrophone.**—A word proposed for a carbon-contact telephone transmitter.
- Electrophor.**—An orthography sometimes employed for electrophorous.
- Electrophoric.**—Of or pertaining to an electrophorous.
- Electrophoric Medium.**—A word sometimes employed for a dielectric medium.
- Electrophorous.**—A simple form of electrostatic induction apparatus.
- Electropoion Liquid.**—An exciting liquid, consisting of one part of bichromate of potash dissolved in ten parts of water, to which two and a half parts of sulphuric acid have been gradually added.
- Electroscope.**—An apparatus for showing the presence of an electric charge, or determining its character, whether positive or negative, but not for measuring its amount or value.
- Electroscopic Gauge.**—A term formerly applied to an early form of discharging gold-leaf electroscope.
- Electroscopically.**—By means of an electroscope.
- Electroscopy.**—The art of determining, by means of an electroscope, the character of an electric charge.
- Electrostatic.**—Of or pertaining to electrostatics.
- Electrostatic Attraction.**—The mutual attraction existing between unlike electric charges.
- Electrostatic Aurora.**—Luminous phenomena attending the production of an electrostatic corona.
- Electrostatic Balance.**—A form of balance employed for the measurement of high, direct, or alternating electromotive forces, by the electrostatic effects produced by their charges.
- Electrostatic Capacity.**—The quantity of electricity which must be imparted to a given conductor as a charge, in order to raise its potential to unity, all neighboring conductors being at zero potential.
- Electrostatic Capacity of a Line.**—The power possessed by an electric line wire or conductor to act as a condenser. (2) The capacity of a line or conductor for holding an electric charge, as a condenser.
- Electrostatic Charge-Current of Cable.**—A momentary and violent rush of current that occurs on the application of an electromotive force to a submarine cable.
- Electrostatic Circuit.**—A circuit formed by lines of electrostatic flux with an electric source.
- Electrostatic Corona.**—A luminous effect produced on the surface of a thin sheet of mica, or other insulating material, when placed between two electrodes, subjected to a comparatively high difference of potential.
- Electrostatic Current.**—The time-rate-of-flow of electrostatic flux.
- Electrostatic Difference of Potential.**—The difference of potential due to electric charges.
- Electrostatic Discharge.**—A term sometimes employed for a disruptive discharge.
- Electrostatic Field.**—(1) The region of electrostatic influence surrounding a charged body. (2) A region traversed by electrostatic flux.
- Electrostatic Flux.**—A stress in the ether which proceeds from a charged body along definite curved lines or paths.
- Electrostatic Flux-Paths.**—The paths traversed by electrostatic flux.
- Electrostatic Force.**—The force which produces the attractions or repulsions of charged bodies.
- Electrostatic Generator.**—A general term applied to various forms of influence machines.
- Electrostatic Hysteresis.**—(1) The energy consumed in an alternating-electrostatic field by the dielectric medium. (2) Dielectric hysteresis.
- Electrostatic Indicator.**—A name sometimes applied to an electrometer.
- Electrostatic Induction.**—The induction of an electric charge produced in a conductor brought into an electrostatic field.
- Electrostatic Induction-Machine.**—(1) A machine in which a small initial charge produces a greatly increased charge by its inductive action on a rapidly rotated disc of glass or other dielectric. (2) An electrostatic influence machine.
- Electrostatic Influence.**—A term sometimes used instead of electrostatic induction.

- Electrostatic Leakage.**—The gradual dissipation of a charge due to insufficient insulation.
- Electrostatic Lines of Force.**—(1) Lines of force produced in the neighborhood of a charged body, by the presence of the charge. (2) Lines extending in the direction in which the force of electrostatic attraction or repulsion acts.
- Electrostatic Motion.**—Motion produced by an electrostatic field somewhat similar to motion produced by a magnetic field.
- Electrostatic Motor.**—(1) A motor driven by means of the induction of two varying electrostatic fields at right angles to each other. (2) Generally, a motor driven by the interaction of two or more electrostatic fields.
- Electrostatic Optical Strain.**—A strain or deformation produced in an optical medium by the stress of an electrostatic field.
- Electrostatic Potential.**—(1) The power of doing electric work possessed by a unit quantity of positive electricity residing on the surface of an insulated body. (2) That property in space by virtue of which work is done when an electric charge is moved therein.
- Electrostatic Repulsion.**—The mutual repulsion produced by two similar electrostatic charges.
- Electrostatic Resistance.**—The resistance offered by any medium to the passage of an electrostatic flux or an electrostatic current.
- Electrostatic Retardation.**—Retardation in signalling, on long telegraphic lines, due to electrostatic capacity.
- Electrostatic Screening.**—Screening or shielding from the inductive effects of an electrostatic charge.
- Electrostatic Strain.**—Strain produced by the stress of an electrostatic field.
- Electrostatic Stress.**—The force or pressure in an electrostatic field which produces electrostatic strain in any substance placed therein.
- Electrostatic Time, Constant.**—In an electric circuit or condenser, possessing capacity and resistance, the product of the capacity and the resistance, usually expressed in seconds or farad-ohms.
- Electrostatic Units.**—Units based on the attractions or repulsions of two unit charges of electricity at unit distance apart.
- Electrothanasing.**—Producing accidental death by means of electricity.
- Electrothanasias.**—A word proposed for accidental death produced by electricity. (Not in use.)
- Electrothanasise.**—To produce accidental death by electricity.
- Electrothanasose.**—A word proposed for capital punishment inflicted by means of electricity. (Not in use.)
- Electrothanasotic.**—Of or pertaining to capital punishment by means of electricity.
- Electrothanasosing.**—A word proposed for execution by electricity.
- Electrotisis.**—A word proposed for capital punishment by means of electricity. (Not in use.)
- Electrotome.**—A term sometimes applied to an automatic contact-breaker which vibrates with sufficient rapidity to produce a musical sound.
- Electrotonic.**—Of or pertaining to electrotonus.
- Electrotonic Currents.**—In electrotherapeutics, a current due to the internal polarization of a nerve fibre between the conducting core of the nerve and its enclosing sheath.
- Electrotonic Effect.**—An altered condition of excitability produced in a nerve when in the electrotonic state.
- Electrotonic Excitability.**—The actual excitability of a nerve when in the electrotonic state.
- Electro-Tonicity.**—A term sometimes employed for electrotonus.
- Electrotonus.**—The condition of altered functional activity which occurs in a nerve when subjected to the action of an electric current.
- Electrozemia.**—A word proposed for capital punishment by means of electricity. (Not in use.)
- Electrum.**—A name given by the ancients to various substances that could be readily electrified by friction.
- Element.**—(1) Any kind of matter which cannot be decomposed into simpler matter. (2) Matter that is formed or composed of but one kind of atoms.
- Element of Current.**—A term employed in mathematical discussions to indicate a very small part of a current, for ease in considering its actions.
- Element of Storage Battery.**—(1) A single set of positive and negative plates of a storage cell, so connected as to be ready for placing in the acid liquid of the containing jar or vessel. (2) A term some-

- times applied to one of the storage cells of a battery.
- Element of Voltaic Cell.**—Either of the substances forming the couple of a voltaic cell.
- Elements of Armature Winding.**—The separated conductors forming the parts of an armature winding.
- Elementary Matter.**—Matter which cannot be decomposed into simpler matter.
- Elevator Annunciator.**—An annunciator connected with an elevator to indicate the floor from which a signal is sent.
- Elevator, Electric.**—An elevator operated by means of an electric motor.
- Elevator Switch.**—A switch operated from an elevator for controlling the operation of the elevator motor.
- Elliptical Rotary-Magnetization.**—The magnetization which exists in a diphas motor when two alternating-magnetic fluxes coexist while out of phase with each other.
- Elliptical Rotation.**—A rotation as of a point on an ellipse.
- Elliptically Rotating Magnetic Field.**
(1) A magnetic field which is subject to elliptical rotation. (2) The rotation of magnetic flux produced by two diphas currents of unequal intensity, or of equal intensity, but not of 90° phase difference.
- Elongated Ring-Core.**—A hollow cylindrical core of comparatively great length.
- Elongation of Needle.**—A phrase sometimes used for the maximum angular deflection of a needle, or the maximum deflection of the spot of light on a galvanometer scale, when making one or more swings.
- Embedded Coils.**—(1) Coils or windings placed in grooves or perforations on the armature of a dynamo or motor. (2) Iron-clad armature coils.
- Embossing Telegraphic Instrument.**
A registering telegraphic instrument in which the signal is recorded in embossed characters on a paper fillet.
- Emergency Brake.**—(1) A brake on a vehicle employed only in emergency. (2) In an electrically propelled vehicle a brake of greater power than the ordinary brake, and used only in emergency, as, for example, a reversing switch to reverse the direction of rotation of the motors.
- Emergency Cable.**—A small, comparatively inexpensive and easily handled cable, employed in the case of breaks in a pole line due to floods, railroad wrecks, etc., for opening up communication during repairs of the break.
- Emergency Crew.**—A crew or gang in a power distribution system for service in case of a break-down, emergency, or fault on the line.
- Emergency Switch.**—An accessory switch placed on a car controller for reversing the motion of a car when necessary.
- Electrotisic.**—Pertaining to capital punishment by means of electricity.
- Electrotising.**—Inflicting capital punishment by means of electricity.
- Emissivity.**—The specific radiating power of a surface, or its ability to emit or throw out radiant energy, usually expressed in ergs per sq. cm.
- Emissivity of Filament.**—The ability of a filament to emit or radiate light and heat when traversed by an electric current.
- Emmetropic Eye.**—The normal human eye, or the human eye in its normal adjustment and capability of accommodation.
- Empanelled Wires.**—Wires placed inside mouldings, or behind panels.
- Emptied.**—A term sometimes applied to a discharged secondary or storage battery, or to a discharged condenser.
- Enamelled Rheostat.**—A rheostat whose coils consist of wires imbedded in a mass of enamel, in close juxtaposition to a mass of iron or other heat-conducting material.
- Enclosed Arc-Lamp.**—An arc-lamp whose carbons are enclosed by a closely fitting globe, so as to maintain an atmosphere around the arc practically devoid of oxygen, thus diminishing the rate of consumption of the carbons.
- Enclosure of Magnetic Flux.**—(1) Linkage of magnetic flux. (2) Confining magnetic flux in a ferric magnetic circuit.
- End Connections.**—End windings.
- Endlessness.**—The condition of a closed ring of uniform cross-section in which the magnetizing coils are wound uniformly all around it, and a practically endless or uniform magnetic field is obtained throughout the length of the ring.
- Endoscopic Lamp.**—A lamp provided for the examination of a bodily cavity through its natural outlet.
- Endosmometer.**—An apparatus for measuring the strength of endosmotic currents.
- Endosmose.**—The unequal mixing of two different liquids or gases through the pores of an interposed medium.

Endosmose, Electric.—(1) The unequal mixing of two liquids through the pores of an interposed septum on the passage of an electric current through the septum. (2) The transfer of liquid through an immersed septum traversed by an electric current.

Endosmosis.—A word frequently employed in place of endosmose.

Endosmotic Equivalent.—The ratio between the amount of water that passes through a porous membrane into a saline solution, and the amount of salt that passes in the opposite direction.

Endothactic Cut-out.—A cut-out arranged to throw a device into a circuit.

Endothactic Switch.—A switch which is arranged to cut a device into a circuit.

Endothermic.—Of or pertaining to the absorption of heat.

Endothermic Reaction.—A chemical action attended with the absorption of heat.

End-to-End Joint.—A term frequently employed in place of butt-joint.

End Windings.—(1) End connections. (2) Conductors for connecting up bar windings at the end of an armature.

Energetics.—That branch of mechanics which treats of the transfer of energy or of its transformation.

Energy.—The power of doing work.

Energy Component of Current.—(1) In an alternating-current circuit the component of current which is in phase with the impressed E. M. F. (2) In an alternating-current circuit, the product of the E. M. F. and the effective conductance.

Energy Component of E. M. F.—(1) In an alternating-current circuit the component of E. M. F. which is in phase with the current. (2) In an alternating-current circuit, the product of the current and the effective resistance.

Energy Current.—(1) A term sometimes used for active component of current in an alternating-current circuit, as distinguished from the wattless component of current. (2) The product in an alternating-current circuit of the effective conductance and the E. M. F.

Energy Efficiency of Storage Battery. The watt-hour efficiency.

Energy, Electric.—The power which electricity possesses of doing work.

Energy Electromotive Force.—(1) The energy component of E. M. F. in an alternating-current circuit. (2) The component of E. M. F. which is in phase with the current strength.

Energy Flux.—(1) A stream of energy transfer. (2) A surface integral of energy transferred through a surface.

Energy Meter.—A term sometimes applied to a wattmeter.

Energy of Motion.—A word sometimes used for kinetic energy.

Energy of Position.—A word sometimes used for potential energy.

Energy of Strain.—A term sometimes used for potential energy of deformation elasticity.

Energy Resistance.—In an alternating-current circuit, the energy component of impedance.

Energy Storage-Capacity.—The total amount of energy which a storage cell can store up expressed in watt-hours.

Energy Transforming-Device.—Any device which will transform or change energy from one form to another.

Engaged Test.—(1) In telephony, the busy test. (2) A test made by the operator at a central exchange to ascertain whether the subscriber desired is already engaged in telephonic communication.

Engine.—In telephony, a name sometimes used for a ringer or magneto-generator.

Engine Dynamo.—A direct-connected dynamo.

Engine Plane Signal.—In a system of mine signalling a circuit containing a battery and bell at the engine house, and a pair of uncovered iron wires along the engine plane, or hoist run, for the purpose of giving signals to the man at the engine.

Engine-Room Indicator.—An indicator placed in an engine-room.

Engine-Room Tachometer.—A tachometer suitable for permanent attachment to an engine, dynamo, or other rotating machine situated in an engine-room.

Engine Telegraph.—A telegraph on board ship for communicating orders to the engine-room.

English Heat Unit.—(1) The British heat unit. (2) The heat necessary to raise a pound of water 1° F.

Engraving, Electric.—A method for electrically etching or engraving a metallic plate by covering it with wax, tracing the design on the wax so as to expose the metal, connecting the metal with the positive terminal of a battery, and placing it in a bath opposite another plate of metal, so that it will be electrically corroded on its exposed parts.

Entering Current of Telegraphic Circuit.—A term employed to designate the

current on a telegraphic line or conductor near the battery.

Entrefer.—(1) The gap of non-magnetic material through which the field flux has to pass at the surface of the armature of a dynamo-electric machine, composed either of an air-gap or of air and copper. (2) The width of the non-magnetic gap, as distinguished from the width of the clearance or simple air-gap of a smooth cored armature.

Entropy.—(1) In thermo-dynamics the non-available energy in any system. (Clausius and Mayer.) (2) In thermo-dynamics the available energy in any system. (Tait, Thomson, Maxwell.)

Entropy, Electric.—A term proposed by Maxwell for use in thermo-electric phenomena, to include the doctrine of entropy in electric science.

Environment.—The accompaniments or surroundings of any thing or condition.

Eolotropic.—(1) Heterogeneous with respect to direction. (2) A medium in which equal stresses applied in different direction do not produce equal and similar strains.

Eolotropic Dielectric.—A dielectric possessing eolotropic properties.

Eolotropic Medium.—Any medium possessing eolotropic properties.

Eolotropic Wire-Grating.—An eolotropic screen employed by Hertz in his experiments on electric radiation.

Eolotropism.—The possession of eolotropic properties.

Eolotropy.—The doctrine, theory, or condition of eolotropism.

Epoch.—In the case of a vibrating body, the time or the angle reckoned from the point of starting to the point of maximum positive elongation.

Equal Arms Electric Balance.—An electric Wheatstone bridge or balance employing equal arms.

Equal Deflection Method.—A method of measuring a resistance, electromotive force or current which consists in obtaining the same deflection on a galvanometer in the circuit with a given shunt.

Equalizer.—(1) An equalizing bar. (2) A term employed for an equalizer wire. (3) A device for equalizing electric pressure over a system.

Equalizer Feeder.—A feeder whose sole or principal purpose is to equalize the pressure between the ends of two or more other feeders, as distinguished from supplying current to feeding points.

Equalizer Feeder-Switch.—A switch employed to throw a feeder equalizer in or out of circuit.

Equalizer Switch.—A switch governing a resistance suitable for feeder regulation.

Equalizer Wire.—(1) An equalizing bar. (2) A wire connecting the series windings of two or more compound-wound generators operated in parallel.

Equalizing Bar.—A bar joining the series coils of two parallel-connected, compound-wound generators, so that any excess of current supplied by the armature of one machine must necessarily excite the other machine to the same extent.

Equalizing Current.—The current passing through an equalizing bar between two dynamos.

Equalizing Dynamo.—A dynamo employed in systems of three or five-wire distribution to supply one pair of mains which may be unduly loaded so as to equalize the pressure.

Equalizing Resistance-Coils.—Resistance coils employed in a system of feeder regulation.

Equalizing Wires.—(1) Two wires or conductors, one of which is employed for connecting the positive brushes and the other for connecting the negative brushes of compound-wound dynamos, when connected in parallel. (2) Wires connecting corresponding segments in a multipolar armature winding.

Equator of Magnet.—(1) A point approximately midway between the poles of a straight bar magnet, or nearly midway from the poles of a horse-shoe magnet, if measured along the bar from each pole. (2) A line of neutral points on a magnet.

Equatorial.—Of or pertaining to the equator.

Equatorial Region of Magnet.—The portions of a magnet which lie near the magnetic equator.

Equatorially.—In the direction of the equator.

Equiangular Impedances.—Impedances which have the same angle.

Equilibrium.—The condition of a body on which several forces are acting, so that their resultant is zero.

Equilibrium of Radiation.—The condition of a radiating body in which the radiant energy it absorbs is equal to that which it emits.

Equimolecular Solutions.—Solutions which contain, in the same quantity of

the solvent, quantities of the dissolved substance proportional to their molecular weights.

Equipotential.—Of or pertaining to an equality of potential.

Equipotential Electrostatic-Surfaces.

(1) Surfaces on or surrounding charged bodies, all points of which are at the same electric potential. (2) Electric surfaces perpendicular to the lines of electric force, over which a quantity of electricity, considered as being concentrated at a point, may be moved without doing work.

Equipotential Magnetic-Surfaces.—Surfaces surrounding the poles of a magnet or system of magnets, where the magnetic potential is the same.

Equivalent Air-Gap.—An air-gap which would have the same magnetic resistance as a joint, assuming the permeability of the metal to be unaffected by the cutting.

Equivalent Conductance.—(1) A conductance such that if inserted in a sinusoidal-current circuit would absorb energy at the same rate as the actual conductance in a non-sinusoidal current circuit. (2) Virtual conductance. (3) The effective conductance of an alternating-current system or conductor.

Equivalent Conductivity.—The molecular conductivity of a solution divided by the valency.

Equivalent Impedance.—Such an impedance in a simple-harmonic-current circuit as would, with the same effective current strength, absorb energy at the same rate as an actual impedance in a complex-harmonic-current circuit.

Equivalent Reactance.—Such a reactance in a simple-harmonic-current circuit as would permit energy to be absorbed, with the same effective current strength, at the same rate as an actual reactance in a complex-harmonic-current circuit.

Equivalent Resistance.—(1) A single resistance which may replace a number of resistances in a circuit without altering the current traversing it. (2) Such a resistance in a simple-harmonic-current circuit as would permit energy to be absorbed, with the same effective current strength, at the same rate as an actual resistance in a complex-harmonic-current circuit. (3) The effective resistance of an alternating-current system or conductor.

Equivalent Resistance and Inductance.—In an alternating-current circuit, or system of circuits, such a resistance and inductance as would, if substituted for the actual system, cause the same

strength and activity of current to pass through the conducting leads.

Equivalent Resistance and Reactance.

Such a resistance and reactance in a simple alternating-current circuit, as would cause the same current both in magnitude and phase to flow in the main leads, as when a number of multiple arc circuits are connected to them.

Equivalent Sinusoid.—A curve representing a sinusoid, which, for purposes of analytical investigation, has been taken as the equivalent in power of a curve of pressure or current which is not sinusoidal.

Equivolt.—A term proposed for unit of electric energy applied especially to chemical decomposition. (Not in general use.)

Erb's Standard Size of Electrodes.—Standard sizes of electrodes, generally adopted in electro-therapeutics.

Erg.—(1) The C. G. S. unit of work, or the work done when unit C. G. S. force is overcome through unit C. G. S. distance. (2) The work accomplished when a body is moved through a distance of one centimetre with the force of one dyne. (3) A dyne-centimetre.

Erg-Meter.—(1) An apparatus for measuring the work of an electric current in ergs. (2) An energy-meter.

Ergometer.—An erg-meter.

Erg : s.—An abbreviation proposed for erg-per-second, the C. G. S. unit of power.

Erg-Ten.—(1) A term proposed for ten million ergs; 10^{10} ergs, or one erg multiplied by 10^{10} . (2) A kilo-joule.

Error.—In telegraphy, a blunder or inaccuracy either of transmitted signals, as in sending a message, or of deciphered, retransmitted, or recorded signals, as in receiving a message.

Escape, Electric.—(1) A partial loss of current to earth by imperfect insulation. (2) A loss of charge on an insulated conductor.

Escapement, Electric.—An electrically actuated clock escapement.

Essential Resistance.—A term sometimes used for internal resistance.

Etching, Electric.—A term sometimes used for electric engraving.

Ether.—The highly tenuous, elastic fluid that is assumed to fill all space, and by whose vibrations or waves, light, radiant heat, and electro-magnetic radiation are transmitted.

- Ether Flow Vortices.**—Vortices in the ether upon whose alleged existence is based a hypothesis for the explanation of magnetic phenomena.
- Ether Path of Reluctivity.**—A conception employed in studying the reluctivity of a magnetic medium which regards the magnetic flux as taking two multiple-connected paths, one the path of metallic-reluctivity through the mass of the substance, and the other the path of ether-reluctivity, through its associated ether.
- Ether Streamings.**—Streamings that are assumed to exist in the ether around a magnet, or around a charged conductor.
- Ethereal.**—Of or pertaining to the ether.
- Eudiometer.**—(1) A voltmeter in which separate graduated vessels are prepared for the reception and measurement of the gaseous products evolved during electrolysis. (2) A graduated glass tube for holding and measuring the volume of the evolved gas.
- Eudiometric.**—Of or pertaining to an eudiometer.
- Eudiometrically.**—By means of an eudiometer.
- Evanescence Telegraphic Signal.**—Any telegraphic signal which is not permanently recorded.
- Evaporation.**—The change from the liquid to the vaporous state.
- Evaporation, Electric.**—The formation of vapors on the surfaces of solid or liquid substances by the influence of negative electrification.
- Even Harmonics.**—In a complex harmonically-varying quantity, the harmonics whose frequencies are even multiples of the fundamental frequency.
- Ewing's Theory of Magnetism.**—A theory of magnetism proposed by Ewing, based on the assumption of originally magnetized particles.
- Excitability of Nerve or Muscular Fibre, Electric.**—The effect produced by an electric current in stimulating a nerve of a living animal, or in producing an involuntary contraction of a muscle.
- Excitant.**—(1) That which excites. (2) The electric or magnetic force which energizes a receptive device.
- Excitation.**—(1) The production of electrification by any means. (2) The production of magnetism by any means. (3) The energizing of any electro or magneto-receptive device. (4) The production of the magnetic field in a dynamo or motor. (5) The stimulation of a muscle or nerve fibre.
- Exciter.**—Anything which causes an excitation.
- Exciter Dynamo.**—A dynamo used for the separate excitation of another dynamo.
- Exciter of Field.**—A dynamo, or other electric source, employed in the separate excitation of the field of a dynamo.
- Exciting Ampere-Turns.**—The ampere-turns in the field-winding of a generator or motor employed for the excitation of its field.
- Exciting Fluid or Liquid of Voltaic Cell.**—The electrolyte of a voltaic cell.
- Execution, Electric.**—Inflicting capital punishment by electricity.
- Exhaust Fan, Electric.**—An electrically driven exhaust fan.
- Exhaust Wheel, Electric.**—An electrically driven rotary device for drawing or exhausting the air from an apartment.
- Exhausted Storage Cell.**—An emptied storage cell.
- Exhausted Voltaic Cell.**—A voltaic cell in a state of exhaustion.
- Exhaustion, Electric.**—Physiological effects resembling those produced by sunstroke, resulting from prolonged exposure to powerful voltaic arcs.
- Exhaustion of Primary Voltaic Cell.**—The inability of a primary voltaic cell to furnish any further current, unless fresh electrolyte, or new positive elements, or both, are supplied to it.
- Exhaustion of Secondary Voltaic Cell.**—The inability of the cell to furnish any further current until again acted on by a charging current.
- Exosmosis.**—The osmotic current which is directed towards the lower level.
- Exothactic Cut-Out.**—A cut-out designed to remove a device from a circuit.
- Exothatic Switch.**—A switch designed to cut a device out of circuit.
- Exothermic.**—Of or pertaining to an exothermic reaction.
- Exothermic Reaction.**—A chemical reaction attended by the evolution of heat.
- Expanding Magnetic Whirls.**—Magnetic whirls sent out from a conductor through which a current of gradually increasing strength is passing, or from a magnet whose magnetism is gradually increasing.
- Expanding of Magnetic Field.**—The increase in the strength of a magnetic flux and of the region traversed by it.

Expansibility.—(1) The quality of being expandible. (2) Possessing the capacity for expansion.

Expansion.—The act of increasing in length, surface, or volume.

Expansion, Electric.—The increase in volume produced in a body by giving it an electric charge.

Expansion Joint.—A joint suitable for tubes or pipes exposed to considerable changes of temperature, in which a sliding joint is provided to safely permit a change in length on expansion or contraction.

Expended Energy.—The energy employed to produce any result.

Exploder, Electric.—A small magneto-electric machine used to produce a high electromotive force, employed in the direct firing of blasts.

Exploration of Magnetic Field.—Mapping out the location and density of a magnetic field by any suitable means.

Explorer, Electric.—An apparatus operated by means of induced currents for the purpose of locating bullets and other foreign metallic substances in the human body.

Exploring Needle.—(1) A form of exploring probe. (2) A magnetic needle employed in exploring a magnetic field.

Explosive Distance.—A term sometimes employed for sparking distance.

Extension Bell.—(1) An extension call-bell. (2) A call-bell situated at a distance from the apparatus to which it calls attention.

Extension Call-Bell.—An additional bell connected with the call-bell of a telephone or other device, and placed in some other portion of a building, for the purpose of calling the subscriber to the instrument when he may be in a distant part of the house.

Extension Plates for Poles.—Double plates forming between them a loop for an upper extension or branch of a guy-rod supporting a pole.

Extension Push-Button.—An auxiliary push-button placed at a distance from a main push-button.

Extensometer.—A form of apparatus for measuring the elongation of a substance under stress.

External Armature Generator.—A generator in which the armature is external to the field frame.

External Characteristic of Dynamo.—A curve showing the E. M. F. at the terminals of a dynamo under varying currents, as distinguished from an internal characteristic showing the internal E. M. F.

External Circuit.—That part of a circuit with which an electric source is connected that is external to that electric source.

External Magnetic Circuit.—(1) That portion of a magnetic circuit which lies outside the magnetic source. (2) That portion of the circuit of a magnet which lies outside its mass or core.

External Magnetic Field.—That portion of a magnetic field which lies outside the body of a magnet.

External-Secondary Resistance.—In the secondary circuit of a transformer, the resistance external to the transformer.

Extra-Current Direct.—A term sometimes employed for the current produced in the primary of a transformer on the breaking of its circuit.

Extra-Current Inverse.—A term sometimes employed for the current produced in the primary current of a transformer on the making of its circuit.

Extra-Current Neutralizer.—A device for reducing electro-magnetic retardation which consists of a shunted condenser inserted in the main circuit.

Extra Currents.—Currents produced in a circuit by self-induction.

Extra-High-Potential System.—In the National Electric Code a potential above 3000 volts.

Extra-High-Potential Wires.—Wires suitable for use in extra-high-potential systems.

Extraneous Field.—A leakage magnetic field.

Extraordinary Resistance.—A term sometimes used for external resistance. (Not in use.)

Extra-European Message.—In Europe a message sent to or received from some point beyond the geographical limits of Europe.

Extra-Polar.—Lying beyond or outside the poles.

Extra-Polar Region.—In electro-therapeutics, the region which lies outside or beyond the therapeutic electrodes.

Eye-Piece.—The ocular of a telescope or microscope.

F

- F.**—A symbol proposed for farad, the practical unit of capacity.
- F.**—A symbol proposed for force.
- \mathcal{F} .**—A symbol for magnetomotive force. (Partly international usage.)
- f.**—A symbol proposed for force. (Partly international usage.)
- F. M.**—A contraction for field magnets.
- F. W. G.**—A contraction for French wire gauge.
- Fac-Simile Telegraph.**—A general term embracing the apparatus employed in fac-simile telegraphy.
- Fac-Simile Telegraphy.**—(1) A system whereby a fac-simile or copy of a chart, diagram, picture, or signature, is telegraphically transmitted from one station to another. (2) Pan-Telegraphy.
- Factor.**—Each of the several quantities which are multiplied together to form a product.
- Factor of Safety.**—(1) The ratio of the computed or measured strength of a structure to the maximum strength it will be called upon to exert. (2) An amount by which the breaking load or stress in any system must be divided in order to obtain the safe load or stress. (3) A multiple of the calculated strength required of a structure adopted to ensure safety.
- Factor of Safety of Demagnetization.**—The ratio of the demagnetizing force in an aero-ferric magnetic circuit corresponding to an actually existing residual flux density, to the actually existing mean demagnetizing force.
- Fahrenheit Thermometric Scale.**—The thermometric scale in which the length of the thermometer tube, between the melting point of ice and the boiling point of water, is divided into 180 equal parts or degrees.
- Fall-Back Indicator.**—A term sometimes employed for drop indicator.
- Fall of Potential.**—The drop of potential.
- Fall of Pressure.**—The drop of pressure.
- Fall of Pressure in Active Conductor.** The fall of pressure due to the passage of the current, and equal to the product of the current strength by the resistance.
- False.**—(1) Untrue. (2) Provisionally assumed.
- False Discharge of Submarine Cable.** An oscillatory discharge produced in a cable as distinguished from an aperiodic discharge.
- False Electric Current.**—A virtual electric current distribution which has no actual existence, but which is assumed in order to comply with the conditions of an electro-magnetic field.
- False Electrification.**—A virtual electrification having no real existence, but which may be assumed in order to determine a given distribution of electro-magnetic energy in a medium.
- False Magnetic Currents.**—Virtual magnetic currents having no real existence but assumed for the purpose of conforming to the requirements of a given electro-magnetic distribution.
- False Magnetic Poles of Earth.**—A term proposed to designate the place or places on the earth which apparently act as magnetic poles, in addition to two true magnetic poles in the neighborhood of the earth's geographical poles.
- False Resistance.**—A resistance arising from a counter electromotive force, and not directly from the dimensions of the circuit, or from its specific resistance.
- False Zero.**—(1) A zero of a measuring instrument accepted at the position it naturally assumes under the action of forces other than those impressed in the measurement. (2) A zero taken midway between two unequal and opposite deflections of a measuring instrument. (3) In Wheatstone-Bridge measurement, the position of the galvanometer needle naturally assumed under the influence of E. M. F. in the bridge before the application of the testing battery. (4) In cable testing the position of the spot of light when the testing battery is disconnected and the galvanometer short-circuit key is open. (5) A cable zero, or zero to the existing current in a cable. (6) The natural zero.
- Fan Guard.**—A wire guard placed around an electric fan, to prevent the revolving blades from coming in contact with surrounding objects.
- Fan Motor.**—(1) An electric motor suit-

- able for driving a fan. (2) An electric motor carrying a fan.
- Far-Leading Dynamo.**—A motor-dynamo placed as a shunt across a pair of long mains, to compensate for their drop in voltage.
- Farad.**—(1) The practical unit of electric capacity. (2) Such a capacity of a conductor or condenser that one coulomb of electricity is required to produce therein a difference of potential of one volt.
- Faraday Effect.**—The rotation of the plane of polarization of a beam of plane polarized light on its passage along a magnetic field.
- Faraday's Cube.**—An insulated room or cube covered on the inside with tin-foil, which, when charged on the outside, gives no electrical indications to an observer on the inside even to delicate instruments.
- Faraday's Dark Space.**—The gap in the continuity of the luminous discharges that occur between the positive and negative electrodes.
- Faraday's Disc.**—A metallic disc movable in a magnetic field on an axis parallel to the direction of the flux.
- Faraday's Net.**—An insulated net of cotton, gauze, or other similar conducting material, capable of being turned inside out without being thereby discharged, and employed for demonstrating the fact that the charge of an insulated conductor is limited to its outer surface.
- Faradic.**—Of or pertaining to Faraday.
- Faradic Adapter.**—A device for readily permitting commercial incandescent-light circuits to be employed for electro-therapeutic work, with an induction coil.
- Faradic Battery.**—A term erroneously used for a faradic coil, or induction coil.
- Faradic Brush.**—A brush-shaped electrode employed in the medical application of electricity.
- Faradic Coil.**—A term sometimes used for a faradic machine, or medical induction coil.
- Faradic Current.**—(1) In electro-therapeutics, a current produced by an induction coil, or magneto-electric machine. (2) A rapidly alternating current, as distinguished from a direct current.
- Faradic Excitability.**—Muscular or nervous excitability produced by the employment of faradic currents.
- Faradic Excitation.**—The excitement of muscle or nerve fibre by faradic currents.
- Faradic Induction Apparatus.**—An induction coil apparatus for producing faradic currents.
- Faradic Irritability.**—Muscular contractions produced by the action of faradic currents on a nerve.
- Faradic Machine.**—Any machine for producing faradic currents.
- Faradism.**—A word sometimes employed for faradization.
- Faradization.**—In electro-therapeutics, the effects produced on the nerves or muscles by the use of faradic currents.
- Faradization of Skin.**—Treatment of the skin by faradic currents.
- Fast Repeater.**—A telegraphic repeater or translator especially designed for rapid signalling.
- Faradometer.**—A term proposed for an instrument designed for the measurement of faradic currents.
- Fast-Speed Telegraphy.**—Automatic or machine telegraphy.
- Fathom.**—(1) A unit of length equal to six feet or two yards. (2) Approximately, the one-thousandth part of a nautical mile.
- Fault.**—Any defect in the proper working of a circuit, due to ground contacts, cross contacts, or disconnections.
- Fault Resistance.**—The resistance of a fault.
- Fault Searcher.**—An instrument employed in connection with a telephone or other sensitive current-detector, for determining the moment when a portion of the cable containing the fault comes on board ship, while the same is being picked up for purposes of repair.
- Feather Edge.**—A strip of wood laid by the side of a layout of cable in a cable tank to protect it from the pressure of superincumbent flakes.
- Feed.**—(1) To supply with an electric current. (2) To move or regulate one or both of the carbon electrodes in an arc-lamp.
- Feed-Line.**—A feeder.
- Feed-Wire Insulator.**—An insulator employed for the support of a feed-wire.
- Feeder.**—One of the conducting wires through which the current is distributed to the main conductors, as distinguished from a conductor which supplies translating devices directly.
- Feeder-and-Main System of Distribution.**—A system for the transfer of electric energy in which, for the purpose of preventing too great a drop of

pressure on the mains, they are connected at suitable points to the feeder wires, instead of to the generator or generators.

Feeder Ammeter.—An ammeter placed in the circuit of a feeder, usually at a switchboard.

Feeder Block.—A block containing a feeder cut-out.

Feeder Box.—A distribution box supplied by a feeder, into which a feeder enters to receive its distributing connections.

Feeder Clamp.—Any clamping device for connecting or fastening a feeder wire to a trolley wire or to a main.

Feeder Cleat.—A clamp furnished with a device whereby a feeder wire may be readily connected to a trolley wire.

Feeder Distribution.—A feeder-and-main system of distribution.

Feeder Equalizer.—A resistance coil inserted in the circuit of a feeder, with or without means for adjustment, for the purpose of equalizing the pressure at the feeding points.

Feeder-Equalizer Resistance.—A feeder regulator.

Feeder-Equalizer Switch.—An equalizer switch employed in feeder systems.

Feeder for Trolley Conductor.—A wire or conductor of low resistance employed for transmitting electric pressure directly from the power station to some distant point of the trolley wire, for the purpose of maintaining the potential at that point.

Feeder-Mechanism for Arc-Lamps.—An arc-lamp feeding mechanism.

Feeder Panel of Switchboard.—A panel of a switchboard, furnished with the necessary switches, voltmeters, ammeters, and safety devices, to which the feeder wires are connected.

Feeder Plug.—A metallic bolt which, when inserted in a trolley car in place of an insulated bolt, establishes connection between the trolley wire and a feeder through the span wire.

Feeder Potential.—(1) The electric potential of any feeder relatively to ground. (2) The difference of potential between any pair of feeder conductors.

Feeder Regulators.—(1) Artificial resistances introduced into the circuit of idle feeders, so as to increase the drop of pressure existing in them. (2) A form of special transformer, whose primary is connected across the mains and its secondary is in series with one feeder wire, and is employed to produce a pressure which, by means of a suitable reversing switch,

either aids or opposes the alternating pressure on the mains. (3) A term sometimes applied to boosters.

Feeder Switch.—Any switch placed on a feeder panel that is connected with the separate feeders and employed for the purpose of connecting or disconnecting a generator with such feeder.

Feeder System.—A system of distribution in which the service wires are connected by means of feeders to certain centres of distribution.

Feeder Tubes.—Underground tubes provided for the reception of the feeder wires.

Feeders.—Wires supplying currents to main conductors at different points, to equalize their potential under load, as distinguished from wires supplying currents directly to the load.

Feeding Centre.—(1) A centre of distribution supplied by a feeder. (2) A feeding point.

Feeding Conductors or Wires.—Feeders.

Feeding Device or Mechanism for Electric Arc-Lamps.—A device for maintaining the carbon electrodes of an arc-lamp at a constant distance apart during their consumption.

Feeding Point.—(1) A point of connection between a feeder and the mains. (2) A feeding centre.

Fender.—A device placed in front of a street car for preventing accidental injury to pedestrians passing in front of the moving car.

Ferranti Effect.—(1) An increase in the electromotive force or difference of potential of mains or conductors carrying alternating currents, which exists towards the end of the same furthest from the terminals that are connected with the source. (2) A negative drop in pressure.

Ferric Circuit.—A ferric-magnetic circuit.

Ferric Inductance Coil.—An inductance coil provided with an iron core.

Ferric Magnetic Circuit.—A magnetic circuit composed wholly of iron.

Ferric Path of Reluctivity.—That portion of the flux paths through iron or other magnetic material, in which the flux passes through the metal proper, as distinguished from that which is assumed to pass through the ether lying within such material.

Ferro-Magnet.—A word sometimes employed for an ordinary magnet made of paramagnetic material, as distinguished

- from a diamagnet, or one formed of diamagnetic material.
- Ferro-Magnetic.**—A word sometimes employed for paramagnetic.
- Ferro-Magnetic Substances.**—Paramagnetic substances.
- Ferro-Magnetism.**—Magnetism possessed by iron or other paramagnetic substances.
- Ferro-Manganese Alloys.**—Various alloys employed for the wires of resistance coils, whose electric resistance is not sensibly affected by changes of temperature.
- Fibre Suspension.**—Suspension of a needle or other system by a fibre of unspun silk, quartz or other suitable material.
- Fibron.**—A variety of insulating material.
- Fictive Layers.**—Layers in a dielectric possessing equipotential surfaces due to the accumulation of charges insufficient to produce a constant potential within the dielectric, but, nevertheless, capable of modifying its potential.
- Fiducial Point.**—(1) A fixed point or reference point in the scale or indications of a galvanometer or other measuring instrument. (2) A temporary zero point.
- Field.**—(1) A term sometimes used for a magnetic field. (2) A term sometimes used for an electrostatic field.
- Field Coils.**—The field-magnet coils of a dynamo-electric machine or motor.
- Field, Electric.**—A term sometimes used in place of electrostatic field.
- Field Frequency.**—The frequency of revolution in a rotating magnetic-field.
- Field-Magnet Coils.**—The magnetizing coils on the field magnets of a dynamo or motor.
- Field-Magnet Regulating Box.**—(1) The field regulating box. (2) A resistance box inserted in the circuit of the field magnets.
- Field Magnets.**—The magnets which produce the magnetic field or flux in which the armature of a dynamo or motor rotates.
- Field of Force.**—(1) The space traversed by electrostatic or magnetic flux. (2) An electrostatic or magnetic field.
- Field of Vortex Ring.**—The field of influence possessed by a vortex ring.
- Field Poles.**—The poles of the field magnets of a dynamo or motor.
- Field-Regulating Box.**—(1) A resistance box, inserted in series with the field magnet coils, for the purpose of varying the strength of the magnetizing current. (2) A regulating box or rheostat connected with the field circuit of a generator, for the purpose of controlling its pressure.
- Field Rheostat.**—A field-regulating box.
- Field Spools of Dynamo or Motor.**—The magnetizing coils of the field-magnets of a dynamo or motor.
- Field Strength.**—The magnetic intensity of a field.
- Field Telegraph Line.**—A semi-permanent telegraph line employed in army telegraphy, connecting headquarters with the divisional generals, and such other stations as may be required.
- Field Windings of Induction Motor.**—Field windings so arranged as to produce a rotating magnetic field when supplied by multiphase or uniphase currents.
- Fieldless Motor.**—A form of motor in which the torque is obtained by the mutual attraction of separate armatures.
- Figure-of-Eight Wire.**—A trolley wire whose cross-section resembles in outline the figure 8.
- Figure of Merit of Galvanometer.**—The reciprocal of the current strength required to produce a deflection of a galvanometer needle through one division of the scale.
- Figures, Electric.**—Figures of various shapes produced on electrified surfaces by the arrangement of dust particles, or vapor vesicles, under the influence of electric charges.
- Filament.**—A slender thread or fibre.
- Filament of Incandescent Lamp.**—The incandescing conductor of an incandescent electric lamp.
- Filament Shadows.**—Markings produced on the inner surface of an incandescent lamp chamber by the deposition thereon of carbon from the filament.
- Filamentous Armature Core.**—A laminated armature core formed of iron wire.
- Filar Micrometer.**—A micrometer ocular in which an angular or linear distance is measured by the movement of a fibre across the field of view, under the control of a screw adjustment.
- Film.**—(1) A thin pellicle or layer. (2) A name sometimes given to an electro-plating or deposit.
- Film Cut-Out.**—(1) A cut-out in which a film or sheet of paper, or mica, is interposed between a line plate and the earth plate, which, when punctured by a spark, short-circuits the instruments on the

- line. (2) A cut-out for a series incandescent lamp, in which a film of paper or other insulator is interposed between the lamp terminals, so that when the filament breaks, the pressure rises at the terminals, and both punctures and short circuits the film, thus cutting out the broken lamp.
- Film Lightning-Arrester.**—A film-cut-out lightning-arrester.
- Filter Pump.**—A pump employed for increasing the rapidity of filtration of a liquid by atmospheric pressure.
- Filtration.**—The separation of a liquid from an undissolved solid or solids mechanically suspended therein.
- Final Cable Test.**—(1) The test made after a cable is laid, to ascertain if the electrical specifications have been met.
- Final Cable Splice.**—(1) The splice in a cable which completes it. (2) The last splice.
- Finding Earth.**—In telegraphy, making earth.
- Finishing Brushes.**—In electro-plating, finer brushes than scratch brushes, employed for polishing.
- Fire-Alarm Annunciator.**—An annunciator used in connection with a system of fire alarms.
- Fire-Alarm Contact.**—A contact so arranged that an alarm is automatically given when a predetermined temperature is reached.
- Fire-Alarm Signal-Box.**—A signal box placed in a street, or other convenient position, by means of which an alarm of fire can be sent.
- Fire-Alarm Telegraph.**—A general term embracing the apparatus employed in fire-alarm telegraphy.
- Fire-Alarm Telegraphy.**—A system of telegraphy by means of which alarms can be sent to a central station, or to the fire-engine houses in a district, from call-boxes placed on the line, or from automatic fire-alarm contacts.
- Fire Ball.**—A term sometimes applied to globular lightning.
- Fire Cleansing.**—Removing grease by the action of fire from articles that are to be electro-plated.
- Fire Extinguisher, Electric.**—A thermostat or mercurial contact, which automatically completes a circuit and thus turns on a water jet for extinguishing a fire, on a certain predetermined increase of temperature.
- Fire-Fly Radiation.**—Any form of luminous radiation containing a small proportion of non-luminous frequencies, and, in this respect, similar to the radiation of the fire-fly or glow-worm.
- Fire-Glow.**—A term employed by the ancients for an aurora.
- Fire Telegraph.**—A fire-alarm telegraph.
- Firing Battery.**—A battery employed in mining, in military, or in naval operations for firing a fuse.
- Firing Filament.**—(1) Subjecting suitably shaped carbonizable material to the carbonizing process, so as to prepare it for use as the filament of an incandescent lamp. (2) Carbonizing a filament.
- Firing Rheostat.**—A rheostat in the firing circuit of a fuse detonator.
- Fish Plate.**—In a system of electric railroads, the plate connecting contiguous rails by bolts.
- Fished Wires.**—Wires that have been introduced into ducts by the application of the fishing process.
- Fishes, Electric.**—Various fishes, such as the eel and the ray, which possess the ability of either protecting themselves, or securing their prey, by giving electric shocks to the objects touching them.
- Fishing Box.**—A term sometimes used for junction box.
- Fishing Conductors.**—The process of threading conductors through the spaces left for them in floors, walls, tubes, or conduits by securing their ends to the end of a convenient length of wire and hauling the latter through in advance.
- Fishing Process.**—The process employed for the fishing of wires.
- Fishing of Wires.**—The process of drawing a wire into its place in a building through floors, walls, or ceilings by placing a wire in a hole at one end and engaging it by a hook from the other, so as to draw it through.
- Fiske's Electric Range-Finder.**—A device by means of which the distance of an object can be readily obtained.
- Fiske's Electric Range-Finder.**—A device by means of which the exact distance of an enemy's ship or other target can be readily determined.
- Fittings.**—(1)—The sockets, holders, arms, etc., required for holding and supporting incandescent electric lamps. (2) Incandescent light fixtures.
- Five-Point Jack.**—In a multiple telephone switchboard, a jack having five separate contact points.

Five-Point Branching Jacks.—In a multiple telephone branching switchboard, five-point jacks connected in parallel to a subscriber's line.

Five-Wire System.—A system, similar in its arrangement to the three-wire system, in which four series-connected dynamos are suitably connected to five wires or conductors.

Fixed Call-Boxes.—District call-boxes so arranged with burglar-alarm circuits, that the alarm is sent to the district station connected therewith.

Fixed Electric Lamp.—A stationary incandescent lamp as distinguished from a portable lamp.

Fixed Resistance.—A resistance whose value is approximately constant, as distinguished from a regulable resistance.

Fixed Secondary.—The secondary of an induction coil that, as is common in such coils, is fixed, in contradistinction to a movable secondary.

Fixture Cut-Out.—A cut-out or safety plug attached to an electric lamp.

Fixture Electric.—(1) Fittings for electric light. (2) A support or electrolier for one or more incandescent lamps rigidly fastened to a wall or ceiling. (3) Any electric apparatus forming part of a permanent installation.

Fixture Wire.—A class of insulated wire suitable for use in electric fixtures.

Flag of Balance.—A small arm pivoted friction-tight upon the movable coils of an electro-dynamometer balance, and capable of adjustment for the purpose of obtaining a correct initial balance.

Flag Signalling.—A system of semaphoric signalling in which a light flag, held in the hand, is waved to the left for the dots, and to the right for the dashes, of the Morse or Continental Code.

Flake of Cable.—A single horizontal layer of a coiled cable.

Flame.—A mass of inflammable gas in a state of combustion.

Flaming Discharge.—The white, flaming, arc-light discharge that occurs between the terminals of a high-frequency, high-potential induction coil, when the current through the primary is increased in strength beyond that required for the sensitive-thread discharge.

Flaming of Carbon Arc.—An irregular burning of a voltaic arc, which occurs when the carbons are too far apart, and the current strength somewhat exceeds the normal.

Flash Signalling.—A method of semaphoric signalling by means of a lantern, or torch.

Flashed Carbon Filaments.—Carbon filaments that have been subjected to the flashing process.

Flashing.—Subjecting carbons to the flashing process.

Flashing Lights.—(1) Lights employed in light-house illumination, that are periodically shaded, so as to produce an intermittence of the light, and thus to permit such light to be readily distinguished from adjacent lights. (2) Any light whose intensity is periodically intermitted.

Flashing of Dynamo - Electric Machine.—A name given to long flashing sparks at the commutator of a dynamo, due to the short-circuiting of the external circuit at the commutator.

Flashing Process for Carbon Filaments.—A process for improving the electrical homogeneity of carbon filaments by the deposit of carbon in their pores and over their surfaces, by exposing the filaments to a gradually increasing electrical incandescence, while surrounded by a carbonaceous gas or liquid.

Flat Board.—A multiple telephone-switchboard whose surface lies in a horizontal plane, as distinguished from a vertical board.

Flat Cable.—A cable the separate conductors of which are laid up side-by-side, so as to form a flat-conductor.

Flat Commutator-Segment.—A commutator segment that has, through wear or otherwise, acquired a flat surface.

Flat Duplex-Cable.—A flat cable containing two separate conductors which are laid up side-by-side.

Flat-Iron, Electric.—An electrically heated flat-iron.

Flat-Ring Armature.—An armature whose core has the shape of a short cylindrical ring.

Flats.—Those parts of commutator segments, the surfaces of which, through wear or otherwise, have become lower than the other portions.

Floating Knife of Cable Gear.—The adjustable guide on the drum of a cable machine, which leads the cable to the surface of the drum.

Flexible.—Capable of being readily flexed or bent.

Flexible Cable.—A stranded cable, or one which can be readily flexed or bent.

Flexible Conduit-System.—A system of conduits for underground wires, so constructed that the conductors or cables it is to contain can be introduced at any time after its completion.

Flexible Electric Heater.—An electric heater made of flexible material, so as to permit its local application to different parts of the body.

Flexible Electric-Light Pendant.—A pendant for an incandescent lamp, formed by its flexible supporting conductors.

Flexible Lamp-Cord.—(1) A flexible cord provided for supporting an incandescent lamp. (2) A flexible cord maintaining electric connection with a semi-portable incandescent lamp.

Flexible Lead.—A conductor that is stranded for the purpose of obtaining flexibility.

Flexible Twin-Lead.—A lead containing two separate parallel stranded conductors.

Float Dynamometer.—A dynamometer for measuring the mechanical activity of a dynamo or motor in which the machine is supported in a floating cradle and connected to its driver or load through a flexible coupling.

Floor-Contact.—A contact placed on the floor and arranged so as to be readily operated by the foot.

Floor Push.—A form of floor contact.

Flow.—(1) The quantity of liquid escaping from an orifice in a given time. (2) The quantity of a fluid that flows past a given point in a given time.

Flow, Electric.—Electric current.

Flow of Energy.—The transmission of energy through the medium or dielectric surrounding a conductor, now regarded as causing the current of electricity which was formerly assumed to flow through the conductor.

Flow of Electrostatic Flux.—The transference of electrostatic flux which constitutes, in reality, the so-called flow of electric current through a conductor.

Flow of Heat.—The quantity of heat which passes through a thermal conductor when subjected to a certain difference of temperature.

Flow of Magnetic Flux.—(1) The quantity of magnetic flux which passes through any magnetic circuit, under a given magnetomotive force, against a given magnetic reluctance. (2) The time-rate of change of magnetic flux through a magnetic circuit.

Flow of Magnetic Induction.—The transmission of magnetic flux from one point of a magnetic circuit to another.

Fluctuating Electromotive Force or Current.—An electromotive force or current which varies periodically in magnitude.

Fluid.—(1) Any substance which readily flows. (2) A liquid or a gaseous substance.

Fluid Depolarizer.—A fluid substance employed in a voltaic cell as a depolarizer.

Fluid, Electric.—Either of the assumed fluids which were formerly believed to be the cause of electric excitement.

Fluid Insulator.—An oil insulator.

Fluidity.—Possessing the properties of fluids.

Fluorimeter.—A fluoroscope.

Fluoresce.—To become luminous when exposed to radiant energy.

Fluorescence.—The property possessed by certain solid and liquid substances of becoming luminous when exposed to radiant energy.

Fluorescent.—Possessing the capability of fluorescing.

Fluorescent Screen.—A screen covered with fluorescent materials.

Fluorescing.—Emitting fluorescent light.

Fluorograph, Electric.—A visible X-ray picture obtained on a fluorescent screen.

Fluoroscopic Examination.—An X-ray examination of the human body by means of a fluorescent screen.

Fluoroscopic Screen.—A screen covered with fluorescent material, and used in connection with the X-rays for fluoroscopic examination.

Fluoroscopy.—The art of examining the body by X-rays in connection with a fluoroscopic screen.

Flush Box.—A box or space, flush with the surface of a roadbed, provided, in a system of underground wires or conduits, to facilitate the introduction of a conductor into the conduit, or the examinations of the conductors.

Flush Key-Switch.—A key switch that is flush with, or does not project beyond, the surface of the wall in which it is placed.

Flush of Current of Arc-Lamp.—The current that flows into an arc-lamp on starting, and which greatly exceeds in strength, that which flows after the normal arc has been established.

- Flush Plate.**—A plate on which flush push-buttons are mounted.
- Flush Push.**—A push the upper surface of whose button or buttons are flush with the surface of the wall or plate in which it is placed.
- Flush Switch.**—Any switch sunk in a wall, so that its plane outer surface is flush with the surface of the wall.
- Fluviograph, Electric.**—An apparatus for electrically registering the varying height of water in a tidal stream, or in the ocean, or, in general, for any differences of water level.
- Flux.**—(1) Magnetic or electric flux. (2) A surface integral of a vector quantity.
- Flux Density.**—The quantity of magnetic flux per unit of area of normal cross-section.
- Flux Density per-Square-Centimetre or per-Square-Inch.**—The quantity of magnetic flux passing through a circuit per square inch or square centimetre of area of normal cross-section.
- Flux of Displacement.**—The surface integral of electric displacement passing through a closed curve.
- Flux, Electric.**—Electrostatic flux.
- Flux Horn.**—A term proposed for the leading horn or polar edge of a generator which supplies the magnetic flux necessary for reversing the current in the armature coil under commutation.
- Flux Intensity.**—(1) The density of a flux. (2) The surface density of a vector quantity at a point.
- Flux Leakage.**—Any failure of flux to pass through its proper receptive device.
- Flux Lines of Electrostatic Force.**—The lines or paths traversed by electrostatic force.
- Flux of Heat.**—The flow of heat per unit of time through a given area.
- Flux of Light.**—(1) The total quantity of light emitted through a given area by a luminous source. (2) The total quantity of light emitted from a point source.
- Flux of Magnetic Induction.**—The flow of magnetic induction.
- Flux of Magnetism.**—(1) The flow of magnetic induction. (2) The surface integral of magnetic induction through a given surface.
- Flux Oscillations.**—Oscillations in the intensity of electrostatic or of magnetic flux.
- Flux Phase.**—The phase of a simple-harmonic magnetic flux.
- Fly or Flyer, Electric.**—A light wire wheel provided with pointed radial arms, which is set into rapid rotation by the escape of convection streams from its points, when connected with a charged body.
- Flying Break of Armature Conductor.**—A discontinuity in an armature wire that can only be detected when the armature is rotating, owing to the influence of centrifugal force.
- Flying Soundings.**—Approximate soundings, in depths not exceeding two hundred fathoms, obtained without decreasing the speed of the ship below five or six knots per hour.
- Focal Length.**—(1) The distance of a focus from a lens. (2) When not otherwise specified, the principal focal length of a lens or mirror. (3) The distance from the optical centre of a mirror or lens at which parallel rays are brought to a focus.
- Focometer.**—An apparatus for readily determining the focus of a lens or optical combination.
- Focus.**—A point before or back of a mirror or lens, where all the rays of light coming from the lens or mirror either meet, or seem to meet.
- Focusing.**—Altering the distance between an object, and a lens or mirror, in order to obtain a sharp image of the object.
- Focusing Arc-Lamp.**—An arc-lamp designed for use in connection with a reflector or lens, whose mechanism feeds both carbons, and so permits the arc to be maintained at the focus of the reflector or lens.
- Fog, Electric.**—A dense fog which sometimes occurs when there is an unusually large quantity of free electricity in the atmosphere.
- Foiled Conductor.**—A term applied to a conductor whose insulating coating is covered by a thin coating or layer of tin foil or lead.
- Following Edges of Pole-Pieces of Motor.**—Those edges of the pole-pieces of a motor which the armature is leaving.
- Following Horns of Pole-Pieces of Dynamo.**—Those edges or terminals of the pole-pieces of a dynamo which the armature is leaving.
- Foot-Candle.**—A unit of illumination equal to the normal illumination produced by a standard candle at the distance of one foot.
- Foot-Grain.**—A standard for comparing the resistances of wires at a given tem-

perature, the length of the wire being one foot, and its weight one grain.

Foot-Pound.—(1) A unit of work. (2) The amount of work required to raise one pound vertically through a distance of a foot.

Foot-Pound-per-Second.—(1) A unit of activity. (2) A rate-of-doing-work equal to the expenditure of one foot-pound per second.

Foot-Switch.—A switch capable of being readily operated by the foot.

Force.—Anything which changes or tends to change the condition of rest or motion in a body.

Force, Electric.—The force exerted between electrostatic charges.

Force of Field.—The force in a magnetic or electric field independent of the impressed magnetic or electric force.

Force of Flux.—The total magnetic or electric force in a magnetic or electric field, as distinguished from the impressed magnetic or electric forces or from the force of a field.

Force Pump.—A pump provided with a solid piston, and employed for raising liquids through greater vertical heights than that through which such liquids could be raised directly by atmospheric pressure.

Forced Electromagnetic Vibrations.—Electro-magnetic vibrations that are set up in a system independently of its electro-magnetic dimensions.

Forced Vibrations.—A term employed for vibrations set up in a body independently of its nature and form, and other than the free vibrations which the body would acquire, if disturbed and then left to itself.

Forge, Electric.—A forge in which the metal to be operated on is electrically heated.

Fork for Trolley Wheel.—The mechanism which connects the trolley wheel to the trolley pole.

Forked Circuits.—(1) A term used in telegraphy for a number of circuits that radiate from a given central point. (2) In telegraphy, a circuit which divides into two branches, thus connecting three terminal stations.

Forked Lightning.—A variety of lightning flash, in which the discharge, on meeting the earth or other object, divides into two or more branches.

Form Factor of Alternating-Current Curve.—A factor equal to the square

root of the mean square divided by the true mean value of the alternating electromotive force or current.

Formal Inductance of Circuit.—That part of the counter-electromotive force of a circuit which depends on the form of the circuit.

Formed Armature Windings.—Armature coils that are wrapped on a suitable form and afterwards placed on the armature core.

Formed Plates of Secondary Cell.—Plates that have been submitted to the forming process.

Formers.—The forms employed in obtaining formed armature or other windings.

Forming Block.—A block for holding the jack connections of a set or row in a multiple telephone switchboard, for convenience in soldering their contacts with cable conductors, before inserting the set in the switchboard panel.

Forming Storage-Battery Plates.—Obtaining thick coatings of peroxide of lead and of spongy lead respectively, on the lead plates of a storage battery, by repeatedly sending the charging current between them in alternately opposite directions, while immersed in dilute sulphuric acid.

Formulæ.—Mathematical expressions for some general law, rule, or principle.

Forward Induction.—An induction in the field of a motor or dynamo, in which the current in the armature coils produces an induction which assists the field, in contra-distinction to the back induction, which opposes the field.

Forward Lead of Dynamo Brushes.—A displacement of the brushes on the commutator of a dynamo in the direction of rotation of the armature.

Forward Pitch of Armature Winding.—A pitch which is always directed right-handedly, or clockwise, when viewed from the commutator side.

Forward Waves.—In a closed-current circuit supplied by a dynamo giving a harmonic-alternating electromotive force, the wave of induced potential that is assumed to travel through the circuit, from the positive pole of the dynamo to its negative pole.

Foucault Currents.—(1) A name sometimes applied to eddy currents, especially when in armature cores. (2) Useless currents developed in a conducting mass, through which varying magnetic flux is moving.

- Foucault Losses.**—Losses of energy in a dynamo or motor, due to Foucault currents.
- Foundation Trench.**—A trench dug to receive the masonry employed in a foundation.
- Fountain, Electric.**—A fountain operated by electric motors, provided with a variety of jets that are electrically illuminated by different colored lights.
- Fountain Projector.**—An arc-light projector employed in illumining the jets of an electric fountain.
- Four-Conductor Cord.**—A flexible cord containing four separate insulated conductors.
- Four-Pole Switch.**—(1) A switch employed for making or breaking four contacts. (2) A switch employed to open or close a pair of diphase circuits. (3) A double double-pole switch for diphase circuits, one double-pole switch being provided for each circuit.
- Fourier's Series.**—A series of sines or of cosines of multiple arcs.
- Four-Piece Electro-Magnet.**—An electro-magnet constructed in four pieces; namely, two cores, a yoke and an armature.
- Four-Point Switch.**—(1) A switch whose circuit can be completed through four points, either singly, or simultaneously. (2) A four-pole switch.
- Four-Pole Dynamo-Electric Machine.** A dynamo-electric machine whose magnetic field is produced by four magnet poles.
- Four-Speed Regulator.**—A regulator provided with a motor by which four different speeds can be obtained.
- Four-Way Splice-Box.**—A splice-box provided with four ways or tubular conduits.
- Four-Way Switch.**—A four-point switch.
- Four-Wire Diphase-Circuit.**—A diphase circuit, employing four wires in contradistinction to a three-wire diphase circuit.
- Four-Wire System.**—A system similar in its general arrangement to the three-wire system, in which three dynamos are connected to four wires or conductors.
- Four-Wire Transmission.**—A system of electric transmission employing four conductors.
- Fourth State or Condition of Matter.** The ultra-gaseous or radiant condition of matter.
- Fractional Distillation.**—(1) A method adopted for the separation of two or more liquids in solution, by first raising the liquid to the boiling point of the most volatile liquid, and retaining that temperature until all that liquid is evaporated, and then raising the temperature to that of the next most volatile liquid, and so on throughout. (2) The successive separation by distillation of liquids that volatilize at different temperatures.
- Fractional Electrolysis.**—Successive electrolysis of different substances by gradually raising the E. M. F.
- Fracture of Cable.**—A parting or rupture of a submarine cable.
- Frame of Dynamo or Motor.**—A dynamo or motor frame.
- Franklinic Alternating E. M. F.'s.**—Alternating - electromotive forces obtained by means of a frictional or electrostatic-induction machine.
- Franklinic Currents.**—The currents produced by a frictional or electrostatic-induction machine.
- Franklinic Electricity.**—A term sometimes employed in electro-therapeutics for the electricity produced by a frictional or electrostatic-induction machine.
- Franklinism.**—A word sometimes employed for franklinization.
- Franklinization.**—A term employed in medical electricity for electrization by means of a frictional machine, as distinguished from faradization or electrization by means of an induction-coil.
- Franklin's Kite.**—The kite employed by Franklin in demonstrating the identity of lightning and electricity.
- Fraunhofer's Dark Lines.**—Spaces in the otherwise continuous spectrum of the sun where certain frequencies are absent.
- Free Charge.**—The condition of an electric charge on a conductor isolated from other conductors.
- Free Ether.**—A term sometimes employed for the ether that exists in the inter-planetary spaces, as distinguished from the inter-molecular or inter-atomic ether.
- Free Electricity.**—(1) In the old double-fluid hypothesis, a term employed for either the positive or the negative electricity when it is freed from the influence of the other. (2) A term sometimes employed for a charge on an insulated conductor that is isolated from other conductors. (3) A term sometimes employed for the electricity contained in a free charge.

Free Insulated.—The condition of a telegraph wire when it is disconnected from its apparatus and left insulated.

Free Magnet Pole.—A pole in a piece of iron or other paramagnetic substance which acts as if it existed as one magnetic pole only.

Free Magnetism.—(1) In the theory of magnetic matter, magnetism resident upon the polar surface of a magnet and not neutralized by opposite polarity. (2) That portion of the imaginary magnetic matter of a magnet that is distributed over the surface of the magnet.

Free Path.—That path of a gaseous molecule in which it does not collide or strike against another molecule.

Free Vibrations.—Vibrations dependent on the elasticity and shape of a body acquired when the body is acted on by a disturbing force and then left to itself.

Freezing.—Congealing or assuming the solid state by loss of heat.

Freezing Mixtures.—Various mixtures, such as salt and ice, which melt or dissolve on being mixed, and thus absorb sensible heat from themselves, or from surrounding substances.

Freezing of Shaft in Bearing.—The fixing of a shaft in its bearing by the liquefaction and subsequent cooling of its anti-friction metal.

Freezing Point.—The point of congelation of a liquid.

French Measures and Weights.—A system of measures and weights employed generally in physical science, based on the metre as the unit of length, and the gramme as the unit of weight.

French Standard Candle.—The bougie-decimale or the twentieth part of a Violle.

Frequency of Alternation.—(1) The number of cycles or periods executed by an alternating current in unit time. (2) The periodicity. (3) The number of alternations or half-cycles executed by an alternating current in a second or in a minute.

Frequency Setter.—In an alternating-current circuit having induction machines, an alternator which supplies them with a definite frequency.

Frequency Teller.—A device for determining the frequency of an alternating current.

Friable.—Easily crumbled or pulverized.

Friction.—Resistance to the sliding or rolling motion of one body over another.

Friction Brake.—(1) A Prony brake. (2) Any form of brake dependent for its operation on friction.

Fringe of Lines of Force.—A term sometimes used for fringe of magnetic field.

Friction, Electric.—A term sometimes employed for electric resistance.

Frictional Electric Machine.—A machine for the development of electricity by friction.

Frictional Electricity.—The electricity developed by friction.

Frictional Torque.—(1) Torque developed by friction. (2) In a motor the torque necessary to exert on the armature in order to overcome its friction.

Fringe of Magnetic Field.—The lateral extension or diffusion of magnetic flux from the edge of a pole piece whereby the field is not restricted to the space covered by the pole, but extends with diminishing intensity to a greater area.

Frog.—(1) A metallic guide placed on one side of a single track, where a car has to be driven from one track to another, so as to guide the car in the required direction. (2) A grooved piece of metal, serving as a guide, at the intersection of two rails in a track-crossing. (3) A trolley frog.

Front Door Pull.—A circuit-closing device operated by a pull at a front.

Front Stop of Key.—A stop placed on the front of a telegraphic key in order to restrict its motion in a downward direction.

Frost Alarm.—An electric alarm sounded or set in operation by means of a mechanism operated by a fall of temperature to or below the freezing point of water.

Frying of Arc.—The frying sound that accompanies a voltaic arc when the carbons are too near together.

Fulgurite.—A tube of vitrified sand believed to be formed by a lightning discharge into the ground.

Full Battery.—A complete battery employed in the quadruplex system, as distinguished from a reduced battery.

Full Contact.—A complete contact.

Full Load.—(1) An entire load. (2) The maximum load which a machine is designed to carry permanently.

Full-Load Current.—The current of maximum load of a source or station.

Full-Load Efficiency of Motor.—The efficiency of a motor when operating at full load.

Full-Load Efficiency of Transformer.—The efficiency of a transformer, or the ratio of the power yielded at secondary

terminals to the power absorbed at primary terminals, when operating at full load.

Full Metallic-Contact.—A contact which, from its small resistance, establishes a complete connection.

Fuller Voltaic Cell.—A zinc-carbon couple immersed in a solution of electropoion liquid and provided with a layer of mercury around the lower part of the zinc.

Fulminate.—A name given to a class of highly explosive compounds.

Fundamental Frequency.—The nominal or lowest frequency of a complex harmonic electromotive force, flux or current.

Fundamental Tone.—The lowest or dominant tone, or that on which the pitch of a musical note is dependent.

Fundamental Units.—(1) The units of length, time, and mass, to which all other quantities can be referred. (2) Units of length, time, and mass, as distinguished from their derivations, or derived units.

Furnace, Electric.—A furnace in which electrically generated heat is employed for effecting difficult fusions, for the extraction of metals from their ores, or for other metallurgical operations.

Fuse Block.—A block containing a safety fuse or fuses.

Fuse Board.—A board of slate, or other infusible material, on which the safety

fuses in a given installation are assembled.

Fuse Box.—(1) A box containing a safety fuse. (2) A box containing fuse wires.

Fuse Carrier.—A fuse block.

Fuse, Electric.—(1) A device for electrically igniting a charge of powder, by the heat generated in a small strip, wire or mass of poorly conducting material. (2) A safety wire or catch.

Fuse Holder.—A device for holding or protecting a safety fuse.

Fuse Links.—Strips or plates of fusible metal in the form of links employed for safety fuses.

Fuse Panel.—A panel in a switchboard provided for the support of safety fuses.

Fuse Ribbons, Strips, or Wires.—Material for safety fuses in the form of ribbons, strips, or wires.

Fused Electrolytic Bath.—An electrolytic bath in which the electrolyte is maintained in a state of fusion during electrolysis by means of heat.

Fusible Arrester.—A safety catch.

Fusible Plug.—A term sometimes applied to a safety plug.

Fusible Protector.—A safety fuse which acts as a line protector.

Fusing Current.—A term sometimes applied to the current which causes a fuse to blow or melt.

G

g.—(1) An abbreviation or symbol for the gravitation constant, or the force with which the earth acts upon unit mass at any locality. (2) An abbreviation proposed for gramme, the unit of mass in physical investigations.

g.—In telegraphy, an abbreviation for "go ahead."

g. cm².—An abbreviation proposed for the gramme centimetre-squared, the centimetre-gramme-second unit of moment of inertia.

G. M. D.—A contraction for geometrical mean distance.

G. M. T.—A contraction for Greenwich mean time, the standard time used in submarine telegraphy.

G. P.—A contraction for gutta-percha.

Gain Plate of Copper Voltmeter.—The plate of a copper voltmeter that increases in weight due to the deposition on it of metallic copper.

Gains.—The spaces cut in the faces of telegraph poles for the support and placing of the cross arms.

Galvanic Adapter.—An apparatus for obtaining from an electric light circuit feeble continuous currents such as are used in electro-therapeutic applications.

Galvanic Arc.—A term sometimes used for a voltaic arc. (Not in general use.)

Galvanic Battery.—An unadvisable term sometimes used in place of voltaic battery.

Galvanic Cabinet.—A suitably shaped box provided with a voltaic battery and all the accessories necessary for its use in electro-therapy.

Galvanic Cautery.—A term sometimes used in place of electric cautery.

Galvanic Cell.—A name sometimes used in place of voltaic cell.

Galvanic Chain.—A galvanic circuit.

- Galvanic Circle.**—A term sometimes used for galvanic circuit.
- Galvanic Circuit.**—A name sometimes used for voltaic circuit.
- Galvanic Couple.**—A name sometimes given to a voltaic couple.
- Galvanic Dosage.**—A name sometimes given to electro-therapeutic dosage.
- Galvanic Electricity.**—An undesirable term sometimes used in place of voltaic electricity.
- Galvanic Etching.**—A term sometimes used for electric engraving.
- Galvanic Excitability.**—A term sometimes used for electric excitability of nervous or muscular fibre.
- Galvanic Induction.**—A term sometimes used for voltaic induction.
- Galvanic Irritability.**—Muscular contractions produced by the action of voltaic currents.
- Galvanic Multiplier.**—A term formerly applied to a galvanometer.
- Galvanic Polarization.**—A term sometimes applied to the polarization of a voltaic cell.
- Galvanic Ring.**—A term sometimes applied to a voltaic circuit.
- Galvanic Taste.**—The sensation of taste produced when a voltaic current is passed through the tongue.
- Galvanism.**—An inelegant term sometimes employed to express the effects produced by voltaic electricity.
- Galvanist.**—One skilled in the art of galvanism. (Obsolete.)
- Galvanized.**—(1) Subjected to the influence of galvanism. (2) Covered with a coating of zinc by immersion in a bath of molten zinc.
- Galvanized Iron.**—Iron coated with zinc.
- Galvanized Iron Wire.**—A zinc-coated iron wire.
- Galvanizing.**—(1) Covering iron with an adherent coating of zinc by dipping it in a bath of molten metal. (2) Subjecting a nerve or muscle to the action of galvanism.
- Galvanizing Wire.**—Covering wire with a coating of zinc by dipping it in a bath of molten metal.
- Galvano.**—A word sometimes used in place of electro, either for an electro-type or for an article reproduced in copper by electro-metallurgy.
- Galvano-Caustic Loop.**—(1) A loop of platinum wire suitably supported, so as to be shortened at will, and employed for removing diseased growths by drawing it, while heated to electric incandescence, through the parts to be removed. (2) An electric cautery.
- Galvano-Cautistics.**—A term sometimes employed for the destruction of diseased tissues by electrolysis.
- Galvano-Causty.**—A term sometimes employed for galvano-cautery.
- Galvano-Cautery.**—An electric cautery.
- Galvano-Electric Cautery.**—An electric cautery.
- Galvano-Faradization.**—(1) In electro-therapeutics, the simultaneous excitation of a nerve or muscle, by both a voltaic and a faradic current. (2) A pulsating, continuous current.
- Galvanoglyphy.**—A word proposed for the process of producing an electro-type. (Not in use.)
- Galvanography.**—The process of building up a picture in colored varnish, whose varying thickness gives the necessary gradations of light and shade; subsequently black-leading the picture, and depositing a layer of copper by electro-plating, and employing the finished picture as an engraved plate for printing.
- Galvano-Magnet.**—A word sometimes used for electro-magnet. (Not in use.)
- Galvano-Magnetic.**—A word proposed for electro-magnetic. (Not in use.)
- Galvano-Magnetism.**—A word proposed for electro-magnetism. (Not in use.)
- Galvanometer.**—(1) An apparatus for measuring the strength of an electric current by the deflection of a magnetic needle. (2) A current measurer.
- Galvanometer Constant.**—(1) The constant of calibration of the galvanometer scale. (2) The numerical factor connecting a current passing through a galvanometer with the deflection produced by such current. (3) The value of one division of the galvanometer scale in terms of resistance or current strength.
- Galvanometer Shunt.**—A shunt placed around a sensitive galvanometer in order to protect it from the effects of a strong current, or for reducing its sensibility.
- Galvanometer Switch.**—A switch employed with a dynamo balance-galvanometer.
- Galvanometer Voltmeter.**—Any form of galvanometer arranged so as to readily measure a difference of potential.
- Galvanometric.**—Of or pertaining to a galvanometer.

- Galvanometrical.**—Of or pertaining to a galvanometer.
- Galvanometrically.**—In the manner of a galvanometer.
- Galvanometry.**—The determination of the current strength by means of a galvanometer.
- Galvano-Plastic Adhesion.**—Adhesion to surfaces produced by a galvano-plastic deposit between them.
- Galvano-Plastic Bath.**—A plating bath.
- Galvano-Plastic Matrix.**—A mould in which a galvano-plastic deposit is made.
- Galvano-Plastic Soldering.**—Uniting two metallic surfaces by a metallurgical deposit.
- Galvano-Plastics.**—(1) A term sometimes employed for electrotyping, or for producing an electrolytic deposit sufficiently thick to permit of its ready separation from the object on which it has been deposited. (2) Literally, the cold moulding or shaping of metals by electrotyping.
- Galvano-Plasty.**—Galvano-plastics.
- Galvano-Puncture.**—A term sometimes used for electro-puncture.
- Galvanoscope.**—(1) A galvanometer intended to show the existence of a current rather than to measure its strength. (1) A crude or simple form of galvanometer.
- Galvanoscopic Frog.**—The hind legs of a recently killed frog, employed as an electroscope or galvanoscope, by sending electric currents from the nerves to the muscles.
- Galvano-Therapeutics.**—An objectionable term sometimes employed for electro-therapeutics.
- Galvano-Thermal Caутery.**—A term sometimes used for electric cautery.
- Galvanotonus.**—A term proposed for the state of tetanus produced in a muscle that has been over-stimulated electrically.
- Galvanotropism.**—Movements produced in living organisms by the passage of electricity through them.
- Gap Space.**—The air-gap or entrefer.
- Gap Wire Gauge.**—A form of wire gauge in which a gap or set of gaps is left in a plate of metal which may be bridged or filled by the wire to be measured.
- Gas Battery.**—A battery formed of gas cells.
- Gas-Burner, Electric.**—An electric gas-burner that can be electrically turned on and lighted, or electrically lighted after it has been turned on by hand.
- Gas Cell.**—A voltaic couple formed of metals in the presence of gases instead of solids as usual.
- Gas Engine.**—An engine whose motive power is derived from the heat of burning gas.
- Gas-Flame Photometric-Standard.**—A gas-jet photometer.
- Gas-Jet Photometer.**—A photometer in which the standard of light is a gas jet burning with or without a diaphragm at a definite height under standard conditions of volume and pressure.
- Gas-Lighting, Electric.**—The electric ignition of a gas jet from a distance.
- Gas-Lighting Torch.**—A gas-lighting appliance, consisting of the combination of a portable voltaic battery and a spark coil.
- Gas Polarization.**—A term sometimes employed for that form of polarization which is due to the collection of hydrogen gas on the negative plate of a voltaic cell.
- Gas Voltmeter.**—A voltmeter whose indications are based on the volume of gas liberated at a fixed pressure and temperature.
- Gassing.**—The evolution of gas from the plates of a secondary or storage battery.
- Gastroscope, Electric.**—An electric apparatus for the illumination and inspection of the human stomach.
- Gastroscopy.**—The examination of the stomach by the gastroscope.
- Gauge, Electric.**—Any form of portable galvanometer suitable for ordinary testing work.
- Gauss.**—(1) The name proposed in 1894 by the American Institute of Electrical Engineers for the C. G. S. unit of magnetic flux density. (2) A unit of intensity of magnetic flux, equal to one C. G. S. unit of magnetic flux per-square-centimetre of area of normal cross-section. (3) A name proposed for the C. G. S. unit of magnetic potential or magnetomotive force by the British Association in 1895.
- Gaussage.**—(1) The value of the magnetic intensity in gaussess. (2) A name proposed for the value of the M. M. F. in gaussess.
- Gauze Brushes for Dynamo or Motor.** Dynamo or motor brushes formed of wire gauze, or of bundles of parallel plates of thin woven wire.
- Gear Clutch Arc-Lamp.**—An arc-lamp provided with a gear clutch.
- Gearless Car Motor.**—A motor whose speed is such as to permit it to be con-

- ected directly, without intermediate gearing, on the car-wheel axle.
- Geissler Mercurial Pump.**—A mercurial air pump in which the exhaustion is obtained by the aid of a Torricellian vacuum.
- Geissler Tubes.**—Glass tubes, provided with platinum electrodes passed through and fused into the glass, containing the residual atmospheres of gases at a comparatively low vacuum, either with or without fluorescent liquids, or solids, or both, employed to obtain various luminous effects on the passage of electric discharges.
- General Alternating-Current Transformer.**—Any form of alternating-current apparatus in which secondary currents are induced, such as an induction motor or induction generator, as well the ordinary transformer.
- General Faradization.**—A method of employing the faradic current similar to its use in general galvanization.
- General Galvanization.**—A method of employing an electric current therapeutically by the use of electrodes of sufficient size to direct the current practically through the entire body.
- Generator.**—A dynamo-electric machine.
- Generator Ammeter.**—An ammeter measuring the total current output of a generator.
- Generator Bus-Bars.**—The bus-bars which receive the total generated pressure of a number of dynamos, or of a station.
- Generator Panels of Switchboard.**—That panel or set of panels of a central-station switchboard which contains the generator bus-bars, and supports the generator ammeters voltmeters and switches.
- Generator Switch.**—A switch provided for the purpose of connecting or disconnecting a generator from the bus-bars.
- Generator Unit.**—(1) A dynamo-electric generator in a central station. (2) One of a number of independent generating machines in a central station.
- Generator Voltmeter.**—A voltmeter connected with the circuit of a generator, and employed to measure its pressure.
- Geographical Equator.**—The great circle of the earth midway between its poles.
- Geographical Meridian.**—Any great circle of the earth passing through its poles.
- Geomantic Lines of Force.**—The lines of the earth's magnetic force. (Not in general use.)
- German-Silver Alloy.**—An alloy, employed for the wires of resistance coils, usually consisting of fifty parts of copper, twenty-five of zinc and twenty-five of nickel.
- Gig, Electric.**—An electrically propelled gig.
- Gilb.**—A name proposed for the gilbert.
- Gilbert.**—(1) A name proposed for the C. G. S. unit of magnetomotive force. (2) A unit of magnetomotive force equal to that produced by $\frac{1}{1.2566}$ of one ampere-turn.
- Gilbertage.**—The value of the magnetomotive force of a circuit expressed in gilberts.
- Gilding, Electric.**—Electro-plating with gold.
- Gilt Plumbago.**—Powdered plumbago whose conducting power for electricity has been increased by electro-plating it with gold, used for rendering non-conducting surfaces electrically conducting.
- Gimbals.**—Concentric rings of brass, suspended on pivots in a compass box, on which the compass is so supported, as to enable it to remain horizontal notwithstanding the movements of the ship.
- Girder Armature.**—An armature with an H—or girder-shaped core.
- Girder Joint for Rail Bond.**—A name given to a joint in steel rails consisting of two side-clamped girders supporting a tee-bar and double clamped.
- Glass-Bead Hydrometer.**—A bead areometer.
- Glass Fuse.**—A fuse contained in a glass tube with metallic ends.
- Glass Screw Insulator.**—A glass insulator provided with an inside screw thread for attachment to the insulator pin.
- Globe Holder for Arc-Lamp.**—A support provided for holding the globe of an arc-lamp.
- Globe Net for Arc-Lamp.**—A thin wire netting placed on the outside of an arc-light globe.
- Globe Strain-Insulators.**—Insulators provided for the support of the strain wires in an overhead trolley system.
- Globular Lightning.**—A rare form of lightning in which a globe of fire appears quietly floating in the air for a while and then explodes with great violence.

Globular Spark.—An experimentally produced globular discharge obtained from a large condenser.

Glow Discharge.—A form of convective discharge.

Glow Illumination.—(1) A term proposed for an illumination similar to that of a glow-worm; that is, luminous radiation unaccompanied by non-luminous radiation. (2) A term sometimes used for illumination by incandescent electric lamps.

Glow-Lamp, Electric.—(1) A lamp whose light is produced by glow illumination. (2) A term sometimes used for incandescent lamps.

Glow-Worm Radiation.—(1) The radiation of the glow-worm or fire-fly. (2) Radiation that is practically confined within the limits of the visible spectrum.

Glowing of Electric Conductor.—The incandescence of an electric conductor.

Glue-Pot, Electric.—An electrically heated glue-pot.

Glyphography.—The art of forming an electro-type block, whose impressions will produce relief outlines on a flat surface, by covering a flat copper plate with a suitable insulating material, cutting through the same until the copper is exposed, and then coating the surface with plumbago and electro-plating.

Gnomon, Electric.—A term formerly applied to a variety of pith-ball electrometer.

Gold Bath.—An electrolytic bath consisting of a readily electrolyzable solution of a gold salt, a gold plate acting as the anode and placed in the liquid opposite the object to be electroplated, which forms the cathode.

Gold-Leaf Electroscope.—An electroscope in which a pair of leaves of beaten gold is employed to detect the presence of an electric charge, or to determine its character, whether positive or negative.

Gold-Plating.—Electroplating with gold.

Gong Signalling for Railroads.—A system of railroad signals employing a code dependent on the sounds produced by gongs.

Good Earth.—(1) Total or dead-earth. (2) An earth connection whose resistance is negligibly small.

Goose-Neck Double-Pull-Off.—An insulator with a support shaped like a goose neck provided with two points for the attachment of the strain wires and em-

ployed on curves to hold the trolley wire in position.

Goose-Neck Pull-Off.—An insulator, with a support shaped like a goose neck, employed on curves to hold the trolley wire in position, and provided with a single point for the attachment of the strain wire.

Governor, Electric.—A device for electrically controlling the speed of a steam engine, the direction of a current in a plating bath, the speed of an electric motor, the resistance of an electric circuit, the flow of a liquid or gas into or from a containing vessel, or for other similar purposes.

Graded Cyclic-Magnetization.—A regularly expanding or contracting cyclic magnetization.

Graded Winding of Galvanometer.—A galvanometer winding composed of more than one size of insulated wire provided with a view to increasing the sensibility of the galvanometer, and in which the finest wire is placed nearest the axis of the coil.

Gradient.—(1) The increase or decrease of an elevation or quantity with reference to some constant quantity. (2) The space-rate-of-change in a quantity.

Gradient, Electric.—(1) The rapidity of increase or decrease of the strength of an electromotive force or current. (2) The vector space-rate of descent of electric potential at any point.

Graduators.—Devices, generally electromagnetic, employed in systems of simultaneous telegraphic and telephonic transmission over the same wire, so inserted in the line circuit as to gradually obtain the makes and breaks required in a system of telegraphic communication, so that they fail sensibly to influence the diaphragm of a telephone placed in the same circuit.

Gramme.—(1) A unit of mass equal to 15.43235 grains. (2) The mass of a cubic centimetre of water at the temperature of its maximum density.

Gramme Armature-Winding.—The winding originally employed by Gramme on the armature of his dynamo-electric machine.

Gramme Atom.—Such a number of grammes of any elementary substance as is numerically equal to the atomic weight of that substance.

Gramme-Calorie.—(1) The amount of heat required to raise a gramme of water one degree Centigrade. (2) The gramme-degree-Centigrade.

- Gramme Equivalent.**—Such a number of grammes of any substance as is numerically equal to the electro-chemical equivalent of that substance.
- Gramme Molecule.**—A weight of any substance, taken in grammes, numerically equal to its molecular weight.
- Gramme-Ring Transformer.**—(1) A transformer whose primary and secondary coils are placed on a closed iron ring. (2) A transformer resembling a Gramme-ring armature.
- Gramophone.**—An apparatus for recording and reproducing articulate speech.
- Gramophone Record.**—A record of articulate speech obtained by means of a gramophone.
- Granular Carbon Telephone Transmitter.**—A dust telephone transmitter.
- Granular Telephone.**—A word sometimes used for a granular carbon telephone transmitter.
- Graphite.**—A variety of soft carbon suitable for writing on paper or on similar surfaces.
- Grapple Toes.**—The prongs of a grapnel employed in grappling for a submarine cable.
- Graphophone.**—A form of apparatus for recording and reproducing articulate speech.
- Graphophone Record.**—A record of articulate speech received on a graphophone.
- Grappling.**—Recovering a sunken object, such as a cable, by means of a grapnel.
- Grapple.**—A device for hooking and recovering a submerged object, such as a cable.
- Gratings.**—A plate of glass or metal covered with closely-ruled, parallel lines, employed for obtaining diffraction spectra.
- Gravitation.**—Mutual attraction produced between two masses of matter by the force of gravity.
- Gravity.**—The force which causes masses of matter to move or to tend to move towards one another.
- Gravity Ammeter.**—A form of ammeter in which the magnetic needle is moved against the force of gravity by the magnetic influence of the current it is measuring.
- Gravity Annunciator-Drop.**—An annunciator drop which is operated by gravity under the influence of an electric current.
- Gravity-Drop Annunciator.**—An annunciator whose signals are operated by the fall of a drop.
- Gravity-Feed Arc-Lamp.**—An arc-lamp in which the upper or positive carbon is fed, or permitted to drop towards the negative carbon under the influence of gravity, on the operation of the feeding mechanism.
- Gravity Needle-Drop.**—A needle annunciator furnished with a gravity drop.
- Gravity Voltaic Cell.**—A blue-stone gravity cell.
- Gravity Voltmeter.**—A form of voltmeter in which the potential difference is measured by the movement of a magnetic needle against the pull of a weight.
- Grease-Spot Photometer.**—(1) A translucent-disc photometer. (2) A Bunsen photometer.
- Greater Calorie.**—The amount of heat required to raise the temperature of one kilogramme of water from 0° Centigrade to 1° Centigrade.
- Green Candle.**—A standard candle employed in connection with a screen of green glass in order more readily to compare the light of an arc with that of a standard candle.
- Grenet Voltaic Cell.**—A name sometimes given to the bichromate cell.
- Grid Indicator.**—(1) In telephony, a clearing indicator in which the armature is painted with alternate white and black horizontal stripes and fronted by a brass grid. (2) A form of telephone visual clearing indicator.
- Grid.**—(1) A lead plate provided with perforations or other irregularities of surface, and employed in storage cells for the support of the active material. (2) The support provided for the active material on the plate of a secondary or storage cell.
- Grid Plugs.**—Plugs of active material, or of material that is readily rendered active by a charging current, inserted in the perforations of a grid for the purpose of decreasing the time required for the forming of the plates of a storage cell.
- Grip of Belt.**—The hold of a belt on the driving pulley.
- Grothuss' Hypothesis.**—A hypothesis proposed to account for the electrolytic phenomena that occur on closing the circuit of a voltaic cell.
- Ground.**—A general term for the earth when employed as a return conductor.

- Ground Circuit.**—A circuit in which the ground forms part of the path through which the current passes.
- Ground Coil.**—A small rheostat employed in duplex telegraphy at the home station, for the purpose of obtaining the balance of the line at that station.
- Ground Detector.**—(1) In a system of incandescent-lamp distribution, a device placed in a central station for indicating, by the brightness of a lamp, the existence of a ground on the system. (2) An instrument for detecting or measuring grounds or leaks.
- Ground Indicator.**—(1) A tell-tale device employed on a line carrying a current, to instantly indicate any fault in the insulation. (2) An apparatus for detecting a loss of insulation.
- Ground Plate of Lightning Arrester.**—That plate of a comb lightning-arrester which is connected to the ground or earth.
- Ground-Return.**—(1) A general term used to indicate the use of the ground or earth for part of an electric circuit. (2) The earth or ground which forms part of the return path of an electric circuit.
- Ground Shield of Transformer.**—(1) A metallic plate or shield in a transformer separating the primary and secondary coils and connected to ground so as to protect the secondary circuit from any possibility of becoming crossed with the primary. (2) A cylinder of slotted copper placed between the primary and secondary windings of a transformer, so that there can be no accidental contact between the high pressure and the low pressure circuits.
- Ground Wire.**—The wire or conductor leading to or connected with the ground or earth in a grounded circuit.
- Grounded Circuit.**—A circuit, part of whose path is completed through the ground.
- Grounded Dynamo.**—A dynamo whose circuit is accidentally or intentionally grounded.
- Grounding.**—(1) A word sometimes employed in electro-metallurgy for the preparatory process of burnishing. (2) Connecting a circuit to earth or ground.
- Group Incandescent Switch.**—A switch which governs a portion or group of the lamps on an electrolier, or in a room.
- Grouping System for Switchboard Circuits.**—A system of central-telephone-station distribution in which the subscribers are divided into a convenient number of groups, and each group given to the charge of a single operator.
- Growth of Lines of Force.**—The expansion of lines of force.
- Grove's Voltaic Cell.**—A zinc-platinum couple immersed respectively in electrolytes of sulphuric and nitric acid.
- Guard Arm.**—In telegraphic pole-setting, a short upright secured to a pole cross-arm so as to catch a wire should it become detached from the pole.
- Guard Ring of Electrometer or Condenser.**—A conducting ring constructed to form the annular extension of a plate or disc in an air-condenser, for the purpose of preventing any disturbance of electric flux-distribution at the edge of such disc or plate.
- Guard Suspension Wire.**—In a trolley system, a wire supported on the tops of opposite poles for the suspension of a running guard wire, or guard-wires.
- Guard Wire.**—A wire hung above any active conductor, such as a trolley wire, in order to prevent it from coming into electric contact with falling wires.
- Guard-Wire Hanger.**—A hanger employed for the suspension of a guard wire.
- Gutta-Percha.**—A resinous gum obtained from a tropical tree, and valuable electrically for its high insulating powers and for its indestructibility when employed in submarine cables.
- Gutter of Insulator.**—A channel on the side of an insulator, designed to carry off the rain water.
- Guy.**—A rod, chain, rope or wire employed for supporting or stiffening any structure such as a telegraph pole.
- Guy-Rod Bands.**—Bands by which a guy-rod is fastened to a pole.
- Guy Rods.**—Metallic rods employed as guys.
- Guy Rope.**—A rope employed as a guy.
- Guy Stubs.**—(1) A stub or anchor to which a guy is secured. (2) The stub of a pole set in the earth at an angle away from the pole to be guyed.
- Guy Wire.**—A wire employed as a guy.
- Guying.**—Stiffening by means of guys.
- Guys.**—Stays, suitably secured to a post or anchor, for the purpose of steadying an overhead wire system.
- Gymnoticus Electricus.**—The electric eel.
- Gyration.**—The act of turning around an axis.
- Gyrometer.**—A rotary speed-indicator.

Gyroscope, Electric.—A gyroscope driven by an electro-magnetic motor.

Gyrost.—(1) A revolving flywheel designed to display gyrostatic action. (2) A flywheel possessing considerable moment of inertia, suitably supported on pivots within a case, so as to permit of being carried about, and employed to show the

resistance which rotating bodies offer to changing their plane of rotation.

Gyrostatic Action of Dynamo on Ship-board.—The action which occurs at the bearings of a dynamo running on board a tossing ship, whereby gyrostatic stresses are produced.

H

H.—A symbol for the horizontal intensity of the earth's magnetism.

H.—A contraction for the henry or practical unit of self induction.

H.—A contraction for the magnetizing force that exists at any point; or, generally, for the intensity of magnetic force.

H.—A symbol for field intensity.

ℋ.—A symbol proposed for magnetizing force. (Partly international usage.)

h.—An abbreviation for hour, a practical unit of time.

"H. B." Curves.—(1) Curves indicating the relations between magnetizing force and magnetic flux density in a magnetic substance. (2) A term sometimes employed for magnetization curves.

H.P. or ℋ.—A contraction for horse-power.

H.R.—A contraction for high resistance.

H-Armature Core.—(1) An armature core in the shape of the letter H. (2) A girder, shuttle, or I-armature.

H-Poles.—In telegraphy a pair of parallel vertical poles braced together to form one structure, resembling the letter H.

Hæmatocrit, Electric.—An electrically driven device for separating the white blood corpuscles from the red corpuscles by centrifugal force.

Half-Deflection Method.—A method of measuring an electromotive force, current or resistance, by adjusting the circuit in such a way as to halve the galvanometer deflection.

Half-Gate.—The condition of a turbine when operating with the gate half open.

Half-Hoop Magnet.—A magnet in the form of a semi-circle.

Half-Load Efficiency.—The efficiency which a device possesses at half its full load.

Half-Shade for Incandescent Lamp.—A reflecting shade whose outline conforms

to that of the lamp chamber, and covers but half of its surface.

Half-Wire Guard for Incandescent Lamp.—A wire guard which covers but half of an incandescent lamp.

Hall Effect.—A transverse electromotive force produced by a magnetic field in substances undergoing electric displacement.

Halleyan Lines.—A term sometimes used for isogonal lines.

Halpine-Savage Torpedo.—A form of torpedo in which electricity is both the propelling and the directing power, and in which the electric source furnishing the propelling current is contained within the torpedo.

Hand-Brake Mechanism.—A car brake operated by hand.

Hand Dynamo Machines.—A hand generator.

Hand Generator.—(1) A hand-driven dynamo. (2) A hand-driven telephone magneto generator.

Hand-Hole of Conduit.—A box or opening, communicating with an underground cable, provided for readily tapping the cable, and of sufficient size to permit the introduction of the hand.

Hand-Lighting Electric Burner.—A name sometimes applied to a plain pendant burner.

Hand-Operated Alarm.—Any electric alarm operated by hand, as distinguished from an automatically operated electric alarm.

Hand Regulation.—Any regulation of a dynamo effected by the hand, in contradistinction to automatic regulation, such as will preserve constant either the current or the potential.

Hand Regulator.—A resistance box, whose separate coils can be readily placed in or removed from the circuit by means of a hand-operated switch.

Hand Scratch-Brush.—A scratch brush

- operated by hand, as distinguished from one operated by means of a lathe.
- Hand-Signalling.**—Telegraphic signalling by hand, as distinguished from automatic or machine signalling.
- Hand Telegraphic Transmission.**—Manual telegraphic transmission.
- Hand Telephone.**—(1) A telephone receiver held in the hand, as distinguished from a head telephone receiver. (2) An ordinary telephone receiver.
- Hanger Board.**—A form of board provided for the ready replacement or removal of an arc-lamp from a circuit.
- Hanger Cut-Out.**—A cut-out switch for an arc lamp placed under a hanger.
- Hard-Drawn Copper Wire.**—(1) Copper wire that is hardened by being drawn three or four times without annealing. (2) Copper wire not annealed after leaving the die.
- Hard Porous Cell.**—A hard-baked porous cell, whose use in a voltaic cell renders its resistance comparatively high, but which is better able to stand the disintegrating action arising from the crystallization of saline substances present in the battery.
- Hardening.**—Increasing the hardness of certain metals by heating them to a high temperature and then suddenly cooling.
- Hardness.**—That property of a body in virtue of which it resists scratching or cutting.
- Harmonic Analyzer.**—(1) A device for automatically resolving a complex harmonic into its simple-harmonic components. (2) A harmonic receiver. (3) A receiving instrument responding to a single harmonic frequency and which selects that frequency from a complex-harmonic current.
- Harmonic Capacity.**—The capacity of a condenser to a charge or current received from a harmonically varying E. M. F.
- Harmonic Currents.**—(1) Periodically alternating currents varying harmonically. (2) Currents which are harmonic functions of time. (3) Sinusoidal currents.
- Harmonic Electromotive Forces.**—(1) Periodically alternating E. M. F.'s varying harmonically; or harmonic functions of time. (2) Sinusoidal E. M. F.'s.
- Harmonic Frequencies.**—A series of frequencies whose values are integral multiples of the frequency of their fundamental.
- Harmonic Motion.**—(1) Simple-harmonic motion. (2) Simple-periodic motion.
- Harmonic Receiver.**—(1) The receiver employed in systems of harmonic telegraphy, consisting of an electro-magnetic rod tuned to vibrate to a single note or rate only. (2) A receiver designed to respond to a single harmonic frequency in a complex-harmonic current.
- Harmonic Telegraph.**—A general term embracing the apparatus employed in harmonic telegraphy.
- Harmonic Telegraphy.**—(1) A system for the simultaneous transmission of a number of separate and distinct musical sounds over a single wire, employed for simultaneously transmitting an equal number of telegraphic messages. (2) A system of telegraphy employing harmonic currents.
- Harmonic Vibrations.**—The over-tones or higher vibrations into which a complex-periodic vibration may be resolved.
- Harmonics.**—The higher component tones into which any complex tone can be resolved.
- Harmonics, Electric.**—Currents of higher frequencies into which any complex-harmonic current may be resolved.
- Harmonics of Current.**—The harmonic currents into which a complex-harmonic current may be resolved.
- Harmonics of Sound Waves.**—The over-tones or harmonics into which any complex tone may be resolved.
- Harmonograph.**—A mechanical device for compounding any number of simple-harmonic motions of different amplitudes and phases.
- Harness.**—(1) The head and breast equipment of an exchange operator. (2) A term used by telephonists.
- Harpoon, Electric.**—A harpoon containing a bomb that is electrically fired or exploded by the harpooner after the imbedding of the harpoon.
- Harveyizing.**—A method of superficially hardening a steel plate.
- Haulage, Electric.**—Locomotion of a vessel or car by the agency of electricity.
- Head-Bath, Electric.**—A variety of electric breeze applied therapeutically to the head of a patient.
- Head-Gear Telephone.**—A telephone receiver held to the ear by means of a suitable head supporting-gear, thus leaving the hands of the operator free.
- Head-Board of Dynamo.**—An insulating board of a dynamo-electric machine for the reception of terminals or switches.
- Head-Board of Motor.**—A switchboard

connected with a motor for use in starting it.

Head Guy.—A guy attached to the top of a pole.

Head Guying.—A method of pole guying for checking lateral vibrations, in which the top of each pole is guyed to the bottom of the next succeeding pole for a distance of several poles.

Head-Lamp.—An electric lamp placed in the focus of a reflector supported on the head.

Head-Light, Electric.—An electric light placed in the focus of a parabolic reflector in front of an engine or car.

Head of Liquid.—(1) The vertical distance from the level of a liquid in a containing vessel to the centre of gravity of an orifice placed therein. (2) Difference of liquid elevation or level.

Head Receiver.—A head-gear telephone-receiver.

Hearing Tubes.—Tubes connecting a telephone receiver with the ears of the listener.

Heat.—(1) A form of energy. (2) A mode of motion. (3) A vibratory motion impressed on the molecules of matter by the action of any form of energy. (4) A wave motion impressed on the universal ether by the action of some form of energy.

Heat Alarm.—A temperature alarm.

Heat Coil.—(1) A form of protector for switchboards or receptive apparatus generally, consisting of a coil of fine German silver wire wrapped around a small metallic plug, held in its place by a drop of readily fusible solder, and so arranged that on the melting of the solder a spring is permitted to act so as to dead-ground the system. (2) A form of sneak-current arrester.

Heat, Electric.—The heat developed by the passage of an electric current through a conductor.

Heat Insulator.—Any non-conductor of heat.

Heat Lightning.—A variety of lightning flash unaccompanied by audible thunder, in which the discharge lights up the surfaces of neighboring clouds.

Heat Unit.—(1) The quantity of heat required to raise a given mass of water through one degree of the thermometric scale. (2) The calorie.

Heat Units.—Units based on the quantity of heat required to raise a given mass of a substance, generally water, through one degree of the thermometric scale.

Heater, Electric.—A device for the conversion of electricity into heat, employed for purposes of artificial heating.

Heating Effects of Current.—The heat generated by the passage of an electric current through any circuit.

Heavy Escape.—A term employed for a rapid loss of current on a telegraphic line, due to its accidental connection with the ground, as distinguished from a slight loss of current.

Hedgehog Transformer or Converter.—A name applied to a particular form of open-circuited iron-core transformer, in which a core of iron wire projects divergingly from each end of the coil.

Heeling Error of Compass Needle.—The error in a ship's compass needle due to the induced and permanent magnetism of the ship in a vertical plane, which produces no influence upon the needle until the ship heels over, either under a press of canvas, or from any other cause.

Hefner-Alteneck Amyl-Acetate Standard.—(1) The amyl-acetate standard of luminous intensity. (2) A standard lamp of definite dimensions consuming amyl-acetate.

Hefner-Alteneck Amyl-Acetate Lamp.—The lamp employed in the Hefner-Alteneck amyl-acetate standard.

Heilmann Locomotive.—An electrically propelled locomotive which carries not only the steam plant necessary for the operation of the dynamo that furnishes its driving current, but also the motor propelling the truck.

Hekto.—A prefix for one hundred.

Hekto-Ampere.—One hundred amperes.

Hekto-Ampere Balance.—A balance form of ammeter measuring hundreds of amperes.

Hekto-Watt Hour.—(1) One hundred watt-hours. (2) A unit of work equal to one hundred watt-hours.

Helical Coil.—A wire coil containing a number of convolutions or spirals.

Heliograph.—(1) An instrument for telegraphic communication, that operates by employing flashes of sunlight to represent the dots and dashes of the Morse alphabet. (2) A portable instrument for visual telegraphic communication consisting essentially of a mirror supported so as to reflect a beam of sunlight to the distant station, and means to intercept the beam at intervals corresponding to Morse code signals.

Heliographic Transmission.—A system

of telegraphic communication employing the heliograph.

Heliography.—(1) A description of the sun. (2) A term sometimes applied to the fixing of images in the camera obscura. (3) Transmitting or receiving telegraphic signals by means of the heliograph.

Heliostat.—A mirror mounted on an axis parallel to the axis of the earth and so rotated by clock-work as to keep a beam of light reflected from its surface in a constant position, notwithstanding the rotation of the earth.

Heliotropism.—A bending and twisting action produced on the growth of stalks and stems by their exposure to any source of light.

Helix.—A word sometimes used in place of coil or solenoid.

Helm Indicator.—An electrical indicator on board ship for indicating the position at which the helm or rudder stands.

Helmholtz's Galvanometer.—A double-ring tangent-galvanometer, whose two ring coils are parallel to each other, and so placed on opposite sides of the magnetic needle that their magnetic field at the needle may be as nearly uniform as possible, and much more nearly uniform than a single-coil ring can produce.

Hemihedral Crystal.—A crystal whose shape or form has been modified by the replacement of half of its edges or solid angles.

Hemispherical Pole-Pieces.—Pole-pieces of a dynamo-electric machine that provide between them a spherical space for the revolution of an armature.

Hen.—A word proposed for henry. (Not in use.)

Henley's Quadrant Electroscope.—A form of swinging-pendulum electroscope formerly employed for indicating powerful charges of electricity.

Henry.—(1) The practical unit of self-induction. (2) An earth-quadrant, or 10⁹ centimetres.

Henry's Coils.—A number of separate induction coils so connected that the currents induced in the secondary of the first coil, induce currents in the secondary of the second coil with whose primary it is connected in series, and so on throughout all the coils.

Heptad Atom.—An atom whose valency, atomicity, or combining power, is seven.

Hercules' Stone.—A name given by the ancients to the lodestone.

Hermetical Seal.—A seal obtained in a

glass vessel by the fusion of its walls, so as to enable it to hold either a vacuum or a pressure greater or less than that of the atmospheric pressure.

Hertzian Waves.—(1) Electro-magnetic waves given off by an electro-magnet whose intensity is undergoing rapid periodic variations, or by a current whose strength is undergoing rapid periodic variations. (2) Electro-magnetic waves given off from a circuit through which an oscillatory discharge is passing.

Hertz's Axial Oscillator.—A term sometimes employed for Hertz's linear oscillator.

Hertz's Linear Oscillator.—A form of Hertz's oscillator in which a straight or linear conductor is employed instead of a plate as in the ordinary oscillator.

Hertz's Oscillator.—A term sometimes employed for two insulated metallic plates to which are attached metallic rods, terminated by rounded poles or knobs, and separated by an air-gap or space through which disruptive discharges pass.

Hertzian Oscillations.—Hertzian waves.

Heterochromatic Photometry.—(1) Photometric measurements made when the light chosen as a photometric standard emits rays whose frequencies differ from that of the light which is to be measured. (2) Photometry not restricted to light of one color as distinguished from monochromatic photometry.

Heterogeneous Conductor.—(1) A conductor which does not possess the same power of electric conduction in all directions. (2) A non-isotropic conductor, or non-homogeneous conducting medium.

Heterogeneous Dielectric.—A non-homogeneous dielectric, or one which possesses different powers of induction in different directions.

Heteropolar Dynamo.—(1) A dynamo whose conductor moves successively past opposite magnet poles. (2) A bipolar or multipolar dynamo, as distinguished from a commutatorless dynamo.

Heterostatic.—(1) Diversely electrified. (2) A term employed to distinguish a form of electrometer in which the electrification is measured by determining the mutual influence of the attraction exerted by the charge to be measured, and the attraction of a fixed charge imparted to the instrument by a source independent of the charge to be measured.

Heterostatic Electrometer.—(1) An electrometer in which the electrification

to be measured is not the only electrification employed. (2) An electrometer provided with an independent charge.

Hexad Atom.—An atom whose valency or atomicity is six.

Hexode Working.—A term employed for a six-way mode of working by the Delany synchronous multiplex telegraph.

Hick's Automatic Button Repeater.—A manual form of telegraphic repeater.

High-Admittance Motor.—An alternating-current induction motor characterized by high admittance.

High Commutator Bars.—A term applied to those commutator segments, or parts of commutator segments, which, through less wear, faulty construction, or looseness, are higher than the adjoining segments.

High-Economy Lamp.—Any lamp of high efficiency.

High Frequency.—Any frequency much higher than that ordinarily employed.

High-Frequency Currents.—Currents produced by electromotive forces of high frequency.

High-Frequency Induction Motor.—An induction motor operated by high-frequency currents.

High-Frequency Transformer.—A transformer suitable for employment in connection with high-frequency electromotive forces or pressures.

High Insulation.—An unusually good insulation.

High-Potential Current.—A term loosely applied for a current produced by high electromotive forces.

High-Potential Insulator.—An insulator suitable for use on high-potential circuits.

High-Potential Push-Button.—A push button provided for safe use on a high-pressure system.

High-Potential Switch.—A switch suitable for use on high-pressure circuits.

High-Potential System.—In the National Electric Code, any pressure of from 300 to 3,000 volts.

High-Potential Testing Transformer.—An alternating-current transformer for obtaining from an ordinary alternating-current circuit, a high alternating pressure suitable for testing insulation.

High-Potential Wires.—Circuit wires provided with high insulation, and, therefore, suitable for connection with high-potential sources.

High Resistance.—A resistance for any circuit or apparatus, much higher than that ordinarily employed on such circuit or apparatus.

High-Resistance Arrester.—A form of lightning arrester consisting of a number of thin metallic plates separated from one another by means of thin sheets of mica, or other refractory insulating substance.

High-Resistance Magnet.—A term sometimes used for a long-coil magnet of fine wire, possessing a high electric resistance.

High-Resistance Telephone.—A telephone having an unusually high resistance.

High-Pressure Incandescent Lamp.—An incandescent lamp provided with long, thin filaments whose electric resistance is high, and which, therefore, requires a comparatively high pressure for its operation.

High-Reactance Motor.—An alternating-current induction motor possessing comparatively high primary reactance.

High-Speed Electric Motor.—(1) An ordinary electric motor, as distinguished from a motor designed to run at a slow speed. (2) A motor which has its greatest efficiency when running at high speed.

High-Susceptance Motor.—An alternating-current motor possessing comparatively high susceptance.

High-Tension Accumulator.—An accumulator consisting of a number of series-connected secondary cells.

High-Tension Bus.—A bus-bar supplied by a high pressure.

High-Tension Cable.—A cable possessing high insulation and, therefore, suitable for bearing high electric pressures.

High-Tension Circuit.—A circuit employed in connection with high electric pressures.

High-Tension Fuse.—A fuse for igniting an explosive, that is operated by the heating power of an electric discharge of high tension.

High-Tension Switch.—A switch suitable for use in high-tension circuits.

High Vacuum.—(1) A space from which nearly all traces of air or residual gas have been removed, as distinguished from a low or imperfect vacuum. (2) Such a vacuum that the length of the mean free-path of the molecules of the residual atmosphere is equal to or exceeds the dimensions of the containing vessel. (3) A nearly perfect vacuum.

High-Voltage Electro-Magnetic Gen-

- erator.**—An electro-magnetic generator arranged so as to produce a high electro-motive force.
- High-Voltage Incandescent Lamps.**—Incandescent lamps constructed for more than the usual pressure; usually lamps for more than 120 volts.
- Hissing Arc.**—A voltaic arc that emits a hissing sound, due to its carbons being too near together.
- “Hitching Up.”**—A term sometimes employed for boosting.
- Hittorf Effect.**—The effect produced by a Hittorf tube.
- Hittorf Rays.**—The rays emitted by a Hittorf tube.
- Hittorf Tubes.**—Various forms of high-vacuum tubes employed by Hittorf in his researches in electrical discharges through high vacua.
- Hold-Off Spring.**—A spring which acts to keep one thing away from another, in opposition to some force tending to keep it in contact with such thing.
- Hold-On Spring.**—A spring which acts to keep one thing against or in contact with another, in opposition to some force tending to pull it away from such thing.
- Holder for Incandescent Lamp.**—An incandescent lamp-socket.
- Holder for Safety Fuse.**—A support, generally of porcelain or other infusible material, employed for holding a safety fuse and for catching the metal when fused.
- Holders for Brushes of Dynamo-Electric Machine.**—Devices for holding the collecting brushes of a dynamo-electric machine.
- Holohedral Crystal.**—A crystal whose shape or form has been modified by the replacement of all its edges or solid angles.
- Holophane.**—A form of glass globe or enclosing chamber for a source of light, which has its external surface cast into lenticular ridges for the more general diffusion of the emerging light.
- Holophotometer.**—A photometer based on the employment of a Bunsen screen with a system of mirrors, so combined as to avoid errors due to the movements which the lights undergo while being compared.
- Holtz Influence Machine.**—A particular form of electrostatic influence machine.
- Home Battery.**—The battery in a sending station on a telegraphic line, as distinguished from a distant battery.
- Home Station.**—The near or sending station on a telegraphic line, as distinguished from a distant or receiving station.
- Homogeneous Conductor.**—A conductor possessing the same resistivity throughout its length.
- Homogeneous Current-Distribution.**—Such a distribution of current through a conductor in which there is an equal density of current in all parts of a normal cross-section of the conductor.
- Homogeneous Dielectric.**—(1) A dielectric possessing similar properties in all directions. (2) A uniform dielectric.
- Homogeneous Light.**—(1) A light consisting practically of but a single frequency. (2) Monochromatic light.
- Homopolar Dynamo.**—(1) A dynamo whose conductor moves continuously past poles of one polarity only. (2) A commutatorless dynamo. (3) A so-called unipolar dynamo.
- Hood for Arc Lamp.**—A hood provided for the double purpose of protecting the body of an arc lamp from the weather, and for throwing its light in a downward direction.
- Hood Suspension for Arc Lamp.**—A suspension of an arc lamp from a hanger-board placed inside a suitably supported hood.
- Hop System of Space Relations.**—A system of space relations, employed by some electrical writers, which follows the hop tendril; *i. e.*, which considers advance accompanied by left-hand rotation as positive; or that a rotation is positive when accompanied by translation in the manner of a female screw; or, that clockwise rotation is positive when viewed from the front of the clock.
- Horizontal Candle Power.**—(1) The intensity of light emitted by any source in a horizontal direction. (2) The luminous intensity of a source taken in a horizontal direction, as measured in units of luminous intensity.
- Horizontal Component.**—That portion of a force which acts in a horizontal direction.
- Horizontal Component of Earth’s Magnetism.**—(1) That portion of the earth’s directive force which acts in a horizontal direction. (2) That portion of the earth’s magnetic force which acts to produce motion in a compass needle free to move in a horizontal plane only.
- Horizontal Force of Needle.**—The horizontal component of the earth’s magnetic force or magnetism.

Horizontal Intensity of Earth's Magnetism.—(1) The horizontal component of the earth's magnetic intensity at any point. (2) The earth's horizontal magnetic force upon a unit magnetic pole.

Horizontal Intensity of Light.—(1) The intensity of a light measured in a horizontal direction. (2) The flux of a light contained in a small horizontal beam issuing from a source, divided by the solid angle of the beam.

Horizontal Slit Photometer.—A form of spectro-photometer whose slit is horizontal, lying in a straight line joining the sources of light.

Horns of Pole-Pieces of Dynamo.—(1) The edges or terminals of the pole-pieces of a dynamo towards or from which the armature is carried during its rotation. (2) The following or leading horns of the pole-pieces of a dynamo.

Horology, Electric.—That branch of electric science which treats of the application of electricity to the regulation and operation of electric clocks.

Horse.—A support for a dynamo-armature in the process of winding it.

Horseless Carriage.—An automobile carriage.

Horse-Power.—(1) A commercial unit of power, activity, or rate-of-doing-work. (2) A rate-of-doing-work equal to 33,000 pounds raised one foot-per-minute, or 550 pounds raised one foot-per-second. (3) A rate-of-doing-work equal to 4,562 kilograms raised one metre per minute.

Horse-Power, Electric.—Such a rate-of-doing electrical work as is equal to 746 watts, or 746 volt-coulombs per second.

Horse-Power-Hour.—(1) A unit of work equal to the work done by one horse-power acting for an hour. (2) 1,980,000 foot-pounds.

Horseshoe Electro-Magnet.—An electro-magnet whose core has the shape of a horseshoe, or the letter U.

Horseshoe Magnet.—A magnetized bar of steel or hardened iron, bent in the form of a horseshoe, or letter U.

Hot Saint Elmo's Fire.—A term proposed by Tesla for a form of flaming brush-discharge between the secondary terminals of a high-frequency, high-potential induction coil.

Hot-Wire Ammeter.—An ammeter whose readings are based on the expansion of a wire due to an increase of temperature, by the passage through it of the current that is to be measured.

Hot-Wire Thermometer.—A thermometer whose indications are dependent on the expansion of a bi-metallic wire or spiral.

Hot-Wire Voltmeter.—A voltmeter whose indications are based on the increase in the length of a metallic wire placed in the circuit of the electromotive force that is to be measured.

Hotel Annunciator.—An annunciator connected with the different rooms of a hotel.

House Annunciator.—An annunciator connected with the different rooms of a house.

House Mains.—The conductors connecting the service wires with the street mains, in a system of multiple-incandescent lamp distribution.

House Regulator.—An alternating-current apparatus for insertion in the circuit of a group of lamps in a house for the purpose of controlling the candle-power of that group.

House-Service Conductor.—In a system of multiple-incandescent lamp distribution, that portion of the service wire which is included between the street mains and the cut-out within the house.

House Telephone System.—(1) A domestic telephone system. (2) A system for establishing telegraphic communication between different places in a house.

House Wiring.—The wiring in a house for distributing electric currents therein.

House Wires.—The circuit wires employed in a house in a system of distribution.

Howler.—A term sometimes used for a loud buzzer.

Hughes' Electro-Magnet.—(1) An electro-magnet in which a U-shaped permanent magnet is provided with pole-pieces of cast iron on which only are placed the magnetizing coils. (2) A quick-acting electro-magnet whose magnetizing coils are placed on soft-iron pole-pieces that are connected with and form the prolongation of the pole-pieces of a permanent horseshoe magnet.

Hughes' Induction-Balance.—An apparatus for the detection of the presence of a metallic conducting substance in the body by the aid of induced electric currents.

Hughes' Theory of Magnetism.—A theory proposed to account for the phenomena of magnetism by the presence of originally magnetized particles or molecules.

- Hummer, Electric.**—A word sometimes employed for an electric buzzer.
- Hunning's Transmitter.**—The original form of dust telephone transmitter.
- Hunting of Parallel-Connected Alternators.**—(1) A periodic increase and decrease in the speed of alternators, when running under certain conditions in parallel connection as motors or dynamos. (2) Imperfect synchronous running.
- Hydraulic Gradient.**—(1) The gradient representing the drop of pressure between the surface of a liquid in a containing vessel and a discharging orifice connected therewith. (2) The rate-of-drop of pressure in a hydraulic system of distribution.
- Hydraulic Power Dynamometer.**—Any dynamometer suitable for measuring hydraulic power.
- Hydraulic Storage.**—A method of storage of energy consisting in forcing water into elevated reservoirs.
- Hydraulic Transmission.**—The transmission of power by means of pipes containing water under pressure.
- Hydraulics.**—That branch of science which treats of the transmission of water through pipes and the apparatus required for raising or moving water.
- Hydro-Carbon Treatment of Filaments.**—Treatment of incandescent lamp filaments by means of the flashing process.
- Hydro-Dynamics.**—That branch of natural philosophy which treats of the conditions of rest and motion in fluid bodies.
- Hydro-Electric Bath.**—An electro-therapeutic bath in which one electrode is applied to the metallic lining of the bath tub, and the other to the body of the patient.
- Hydro-Electric Generator.**—A term sometimes used for voltaic battery.
- Hydro-Electric Machine.**—A term sometimes used for a machine in which electricity is developed by the friction of a jet of steam over a water surface.
- Hydro-Electro-Therapeutics.**—Curative processes combining electro-pathic and electro-therapeutic treatment.
- Hydrogen Voltmeter.**—A voltmeter whose indications are based on the quantity of hydrogen evolved under a constant pressure and temperature.
- Hydro-Generator, Electric.**—An apparatus for the electrical development of the nascent hydrogen employed in the electrical rectification of alcohol.
- Hygrometer.**—(1) An apparatus for determining the specific gravity of liquids. (2) An areometer.
- Hydrometric Telegraph.**—A form of instrument by means of which signals are transmitted by means of water pressure.
- Hydro-Plastics.**—The art of electrically shaping or depositing metals in the wet, by electro-plating.
- Hydro-Plasty.**—The art of hydro-plastics.
- Hydro-Platinum Rheostat.**—A water rheostat furnished with platinum electrodes.
- Hydrostatic Wire-Testing Machine.**—A machine, operated by hydraulic pressure, for testing the tensile strength of wires.
- Hydrotasimeter, Electric.**—An electrically operated apparatus designed to show at a distance the exact position of any water level.
- Hydrometer.**—An apparatus for determining the amount of moisture present in the atmosphere.
- Hydrometrical.**—Of or pertaining to a hygrometer.
- Hydrometrically.**—In the manner of a hygrometer.
- Hyperphosphorescence.**—(1) A name applied to a variety of phosphorescence in which, after due stimulus, the body exhibits a persistent emission of invisible rays, not included in the hitherto recognized spectrum. (2) A phosphorescence accompanied by the emission of the Becquerel rays.
- Hypothesis.**—A provisional assumption of facts or causes, the real nature of which is still unknown, for the purpose of studying their effects.
- Hypothetical.**—Of or pertaining to a hypothesis.
- Hypsometer.**—(1) An apparatus for determining the height of a mountain or other elevation by ascertaining the temperature at which water boils on such elevation. (2) a hydro-barometer.
- Hypsometrical.**—Of or pertaining to a hypsometer.
- Hypsometrically.**—In the manner of a hypsometer.
- Hysteresial Dissipation of Energy.**—The dissipation of energy by means of hysteresis.
- Hysteresis.**—(1) A lagging behind of magnetization relatively to magnetizing force. (2) Apparent molecular friction due to magnetic changes of stress. (3) A retardation of the magnetizing or demagnetizing effects as regards the causes

- which produce them. (4) That quality of a paramagnetic substance by virtue of which energy is dissipated on the reversal of its magnetization.
- Hysteresis Coefficient.**—(1) The hysteretic coefficient. (2) The energy dissipated in a cubic centimetre of magnetic material by a single cyclic reversal of unit magnetic density.
- Hysteresis Conductance.**—The effective conductance in a transformer or condenser due to the effects of hysteresis.
- Hysteretic Constant.**—The hysteretic coefficient.
- Hysteresis Loop.**—The looped curve which forms the outlines of the graphically represented hysteretic cycle to rectangular co-ordinates of magnetizing force and magnetic intensity or magnetization. (2) A cyclic magnetization curve, forming a closed loop.
- Hysteresis Losses.**—Losses of useful energy due to hysteresis.
- Hysteresis Measurer.**—An apparatus for conveniently estimating or measuring the hysteretic coefficient of a magnetic material.
- Hysteresis Meter.**—A hysteresis measurer.
- Hysteresis Tester.**—A hysteresis measurer.
- Hysteretic Activity.**—Activity expended in producing hysteretic effects.
- Hysteretic Coefficient.**—The activity in watts which would be expended in one cubic centimetre of a metal when magnetized and demagnetized to a flux density of one gauss at one complete cycle or double-reversal per second.
- Hysteretic Condensance.**—In a condenser traversed by an alternating current, the apparent reactance of the condenser, due to or modified by hysteresis.
- Hysteretic Conductance.**—In a condenser traversed by an alternating current, the apparent conductance of the condenser, due to or modified by hysteresis.
- Hysteretic Cycle.**—A cycle of complete magnetization and reversal.
- Hysteretic Energy Current.**—The component of current in phase with the impressed E. M. F. at the primary terminals of a transformer representing the power expended in hysteresis. (2) The energy component of the exciting current of a transformer.
- Hysteretic Energy Electromotive Force.**—The energy component of the E. M. F. of excitation in a transformer.
- Hysteretic Lag.**—The lag in the magnetization of a transformer due to hysteresis.
- Hysteretic Resistance.**—In a condenser traversed by an alternating current, the apparent resistance of the condenser due to or modified by hysteresis.
- Hysteretic Susceptance.**—In a condenser traversed by an alternating current, the apparent susceptance of the condenser, due to or modified by hysteresis.
- Hysteretic Torque.**—That portion of the torque of a dynamo-electric machine due to the influence of hysteresis, whereby mechanical work must be expended in developing hysteretic energy as heat in the iron undergoing magnetic reversal.

I

- I.**—(1) A symbol for strength of current. (2) A symbol for intensity of magnetization.
- ℑ.**—A symbol for intensity of magnetization. (Partly international usage.)
- I. H. P.**—A contraction for indicated horsepower.
- I. I.**—In telegraphy, a signal serving to separate the text of a message from the signature, or the name of the sender.
- I. R.**—A contraction for India rubber.
- I. R.**—A contraction sometimes employed for the drop in an electric circuit, equal to the product of the current in amperes by the resistance in ohms.
- I. S. W. G.**—A contraction for Imperial standard wire gauge.
- I. W. G.**—A contraction for Indian wire gauge.
- I.²R. Activity.**—(1) The activity expended in a circuit, equal to the square of the current strength in amperes by the resistance in ohms. (2) The C² R. activity.
- I.²R. Loss.**—(1) The loss of power in any circuit equal to the square of the current in amperes by the resistance in ohms. (2) The C² R. loss.
- I-Armature.**—An I, or H-shaped armature.
- Ice Clearer for Trolleys.**—A trolley

wheel designed to remove aggregations of ice from a trolley-wire.

Ideal Solenoid.—A solenoid consisting of a cylinder built up of a number of true circular currents, all independent of one another, and all of whose faces of like polarity are similarly directed.

Identical-Electrode Cell.—A term sometimes employed for a double-fluid voltaic cell, both of whose electrodes are formed of the same metal, and whose electromotive forces are dependent on the collection of unlike ions around such plates.

Idio-Electrics.—A term formerly applied to such bodies as amber, resin, or glass, which are readily electrified by friction, and which were then supposed to be electric in themselves. (Obsolete.)

Idiostatic.—Possessing one kind of electrification only.

Idiostatic Electrometer.—An electrometer in which the electrification is wholly due to the potential difference to be measured, as distinguished from a heterostatic electrometer, in which an auxiliary charge is employed from an independent source.

Idle Coil.—(1) Any coil through which for the time no current is passing. (2) Any coil which is not passing through a magnetic field or generating an E. M. F.

Idle Current.—A wattless current.

Idle Current of Alternating-Current Dynamo.—The wattless current of an alternating-current circuit, as distinguished from the active or working current.

Idle Plug.—In a telephone switchboard, a plug not in use.

Idle Poles.—Poles or electrodes in Crookes' tubes between which no discharge is taking place.

Idle Wire.—(1) Any wire through which either no current at all, or no useful current, is passing. (2) Any open-circuited armature wire not generating an E. M. F.

Idle-Wire of Armature.—A term sometimes employed in place of dead wire.

Idle Wire of Armature of Dynamo.—(1) That part of the wire on a dynamo armature in which no useful electromotive force is produced. (2) The dead wire of an armature.

Idle-Wire of Armature of Motor.—That part of the wire on the armature of a motor in which the field produced by the driving current exercises no useful action in driving the motor, since no counter-electromotive force is generated in it.

Igniter.—A carbonaceous material placed between the free ends of a Jablochhoff candle, which becomes incandescent on the passage of the current and so enables the arc to be formed.

Ignition, Electric.—The explosion of a powder, or the lighting of a combustible substance, by electrically generated heat.

Illuminant.—Any source of light.

Illuminated.—A somewhat inelegant orthography for illumined.

Illuminated Dial Instrument.—An instrument for engine-room or central-station use, provided with a translucent dial illumined from the back to render the position of the pointer visible at a great distance.

Illuminating Power.—The amount of illumination produced by any luminous source.

Illumination.—The quantity of light received on a surface per-unit-of-area, either directly from a luminous source or indirectly by reflection and diffusion from surrounding objects.

Illumined.—Lighted up or rendered visible by means of light.

Illumined-Dial Measuring Instrument.—A name applied to any electrical measuring instrument whose dial is so illumined that its scale divisions can be readily seen at a distance.

Illumined Electrode.—That electrode of a selenium cell which on exposure to light develops an E. M. F.

Illuminometer.—An instrument for measuring the illumination of a surface.

Image.—The picture of an object formed by rays from its several points, brought or focused by any suitable means, either on the retina, or on a screen, so as to permit the image to become visible.

Image, Electric.—(1) A term sometimes applied to the charge produced on a neighboring surface by induction from a known charge. (2) An electrified point, or system of points, on one side of a surface, which would produce on the other side of that surface the same electrical action that the actual electrification of the surface really produces.

Imbibition Currents.—Currents produced in tissues by the imbibition or absorption of a fluid.

Immediate False Zero.—A term employed in Wheatstone-bridge measurements in an observation made with reference to that position of the galvanometer needle, as zero, which is assumed,

or which tends to be assumed, immediately after the application of the testing E. M. F.

Immersion Front of Microscopic Object Glass.—That front of a high-power or immersion objective, to which the object is attached by a drop of transparent liquid.

Immersion Gilding.—A gilding or electroplating obtained by a process of simple immersion in a suitable solution of gold.

Immersion Objective.—An object glass of high magnifying power.

Impact.—A shock or collision caused by the meeting of two bodies when one or both are in motion.

Impedance.—(1) Generally, opposition to current flow. (2) The sum of the ohmic resistance, and the spurious resistance of a circuit, measured in ohms. (3) In a simple-harmonic current circuit the square root of the sum of the squares of the resistance and reactance. (4) The apparent resistance of a circuit containing both resistance and reactance.

Impedance Circuit.—A circuit containing impedance.

Impedance Coils.—A term sometimes applied to choking coils, reactance coils, or economy coils.

Impedance Factor.—The ratio of the impedance of a conductor or circuit to its ohmic resistance.

Impedance Rush.—(1) The rush of current produced on closing an inductive circuit. (2) An impulsive current rush.

Impediment.—A term proposed for the apparent resistance of a circuit containing resistance, self-induction, and capacity.

Impenetrability.—That property which prevents any two particles of matter from occupying the same space at the same time.

Imperfect Earth.—Partial earth.

Imperfect Linkage.—(1) Magnetic flux linkage between two coils or circuits, such that some linkage of one circuit is not associated with the other circuit. (2) Coils or circuits possessing mutual induction but also possessing magnetic leakage.

Imperfect Magnetic Circuit.—A term sometimes employed for a magnetic circuit in which, from the magnetizing coils being placed on one part of the core only, the intensity of the flux is greater through some portions of the ferric circuit than through others, so that some of

the lines of induction complete their circuits by passing through the space surrounding the core instead of through the core itself.

Impermeability.—The reciprocal of the permeability.

Impermeance.—The reciprocal of the permeance.

Imponderable.—(1) Possessing no weight. (2) A term formerly applied to the luminiferous or universal ether.

Impressed.—Caused to act or forced upon.

Impressed Electromotive Force.—(1) The electromotive force brought to act in any circuit to produce a current therein. (2) In an alternating-current circuit, the impressed electromotive force due to an impressed source, in contradistinction to the effective electromotive force, or that which is active in producing current, or the electromotive forces due to, or opposed to, self or mutual induction. (3) An applied E. M. F. as distinguished from a resultant, active, or wattless E. M. F.

Impressed Field.—An electric or magnetic field brought to bear upon any substance or space as distinguished from secondary fields thereby set up.

Impressed Pressure.—The impressed electromotive force.

Impulse.—(1) Any single or momentary force acting on a body. (2) The motion produced by a suddenly communicated force.

Impulse of Couples.—The product of the magnitude of a couple, and the time it is acting.

Impulsion Cell.—A photo-electric cell whose sensitiveness to light may be restored or destroyed by slight impulses given to the plate, either by mechanical blows or taps, or by electro-magnetic impulses.

Impulsion Effect.—The restoration or loss of sensitiveness of a photo-electric cell to the action of light, produced by means of an impulse, such as a mechanical tap or blow, or an electro-magnetic impulse.

Impulsive.—Communicated by an impulse.

Impulsive Current-Rush in Inductive Circuit.—An abnormal rush of current which sometimes occurs when a transformer is suddenly switched on to an active main.

Impulsive Discharge.—A discharge produced in conductors by suddenly created differences of potential.

- Impulsive Impedance.**—The impedance encountered by an oscillatory discharge.
- Impulsive Inductance.**—The apparent inductance of a conductor or circuit when subjected to an impulsive discharge.
- Impulsive Permittance.**—The apparent permittance of a conductor or circuit through which an impulsive discharge is passing.
- Impulsive-Rush Discharge.**—An impulsive discharge.
- "In Bridge."**—In multiple to a circuit, as distinguished from being inserted in series with a circuit.
- Inactive Molecules.**—(1) Those molecules of an electrolyte which, during the passage of an electric current, are not resolved into their constituent ions, and which, therefore, have no effect on the molecular conductivity of the electrolyte. (2) The non-dissociated molecules of an electrolyte.
- Incandescence.**—To glow or shine by means of incandescence.
- Incandescence.**—The shining or glowing of a substance, usually a solid, by reason of its elevation to a sufficiently high temperature.
- Incandescence, Electric.**—The shining or glowing of a substance, generally a solid, by means of heat of electric origin.
- Incandescent.**—Shining or glowing with heat.
- Incandescent-Ball Electric Lamp.**—An incandescent electric lamp in which the light is produced by a sphere or ball of carbon placed in an exhausted glass chamber and subjected to electrostatic waves of high frequency.
- Incandescent Bombardment-Lamp.**—An electric lamp in which a refractory material is rendered incandescent by the molecular bombardment produced by the passage of an electric discharge through a rarefied space.
- Incandescent Circuit.**—A circuit provided for the operation of incandescent electric lamps.
- Incandescent-Cut-Out.**—(1) A cut-out suitable for use in an incandescent light circuit. (2) A safety-fuse cut-out.
- Incandescent Filament.**—The incandescing conductor of an incandescent electric lamp, whether of small or of comparatively large cross-section, though generally of the former.
- Incandescent Electric Lamp.**—An electric lamp whose light is produced by the electric incandescence of a strip or filament of some refractory substance, almost invariably carbon.
- Incandescent Electric Lighting.**—Artificial lighting obtained by means of incandescent electric lamps.
- Incandescent Generator.**—A dynamo-electric machine suitable for operating incandescent lamps.
- Incandescent Lamp.**—An incandescent electric lamp.
- Incandescent Lamp-Base.**—The base of an incandescent electric lamp.
- Incandescent Lamp-Cord.**—A flexible lamp cord containing two separate conductors, suitable for use with a pendant incandescent electric lamp.
- Incandescent Lamp-Shade.**—A shade provided for use in connection with an incandescent electric lamp.
- Incandescent Lamp-Socket.**—A socket provided for the reception of an incandescent lamp.
- Incandescent Lighting.**—Artificial lighting produced by the use of incandescent lamps.
- Incandescent Lighting Dynamo-Electric Machine.**—An incandescent generator.
- Incandescent Mantle-Burner.**—(1) A gauze skeleton, or mantle, employed for artificial illumination, made of refractory materials and rendered incandescent by the heat of a Bunsen flame. (2) The mantle of a Welsbach burner.
- Incandescing.**—Producing light by incandescence.
- Incandescing Filament.**—A lamp filament that is producing light by incandescence.
- Incandescing Lamp.**—(1) An incandescent lamp that is actually producing light. (2) An incandescent lamp emitting light.
- Inclination Chart.**—A map or chart on which the isoclinic lines are marked.
- Inclination Compass.**—(1) A magnetic needle, free to move in a single vertical plane only, and employed for determining the angle of dip at any place. (2) An inclinometer or dipping circle.
- Inclination Magnetometer.**—An inclination compass or inclinometer.
- Inclination Map.**—A map or chart on which isogonal lines, or lines connecting places which have the same magnetic dip or inclination, are drawn.
- Inclination of Magnetic Needle.**—(1) The deviation of a mechanically balanced magnetic needle from a horizontal position. (2) The dip of a magnetic needle.

Inclinometer.—An inclination compass.
(2) A word sometimes used for a dipping circle.

Incoming Call.—A call received at an exchange from a subscriber or from another exchange, as distinguished from an outgoing call.

Incoming Call Trunk Line.—A trunk line entering a central telephone station and employed for the reception of calls, as distinguished from an outgoing call trunk line upon which calls are transmitted.

Incoming End.—The end of a junction telephone wire at which calls are received.

Incoming Junction Board.—A switchboard at a central exchange at which incoming junction wires are received and distributed.

Incoming Lines.—Lines at a telephone exchange at which calls are received, as distinguished from outgoing lines.

Incoming Signals.—The signals that are received at the home end of a telegraphic circuit.

Incoming Wires.—Wires leading into a building, room, switchboard, or other device.

Incomplete Circuit.—An open or broken circuit.

Inconductivity.—A word sometimes used for non-conductivity.

Increased Electric Irritability.—Irritability of nervous or muscular tissue produced by a much weaker electric current than that required to produce it in normal tissue.

Increment Key.—A telegraphic key so connected that an increase or increment in the line current occurs whenever the key is depressed, as distinguished from a key which opens or closes a circuit.

Increment Key of Quadruplex Telegraphic System.—A key employed to increase the strength of a current and so operate one of the distant instruments in a quadruplex system, by an increase in the strength of the current.

Independent Circuits.—(1) Separate circuits or those which have no electric connection with other circuits. (2) Circuits in electric connection, but acting independently, as though insulated from each other.

“In-Current” of Telephone Relay.—The current which is received by a telephone relay, for transmission to another circuit.

Independent-Diphase System.—A

phrase sometimes used for the four-wire diphase system.

Indestructibility of Energy or Matter.—A theory which assumes that energy or matter can never be destroyed, and that, consequently, when either disappears in one form or phase, it must reappear in some other form or phase.

Index of Refraction.—(1) The ratio of the sine of the angle of incidence to the sine of the angle of refraction for the light passing from a vacuum into a material medium. (2) A quantity representing the amount of deviation of a ray of light from its original course, on its passage from a standard medium, or vacuum, to another of different density. (3) A quantity representing the ratio of the velocity of wave-propagation in a vacuum to the velocity in a material medium. (4) In the electro-magnetic theory of light the geometric mean of the specific inductive capacity and the magnetic inductivity of a medium to electro-magnetic waves of a given frequency.

India Rubber.—(1) A resinous substance obtained from the milky juices of a tropical tree. (2) Caoutchouc.

Indicating Bell.—An electric bell which, in order to distinguish between different bells in the same office, is provided with an annunciator drop which is released by each bell when it rings.

Indicating-Bell Annunciator.—An annunciator provided for an indicating bell.

Indicating Lamp.—A lamp connected with a circuit, which is lighted or extinguished, or the intensity of whose light is caused to vary, on the occurrence of a predetermined change in the pressure or resistance of the circuit.

Indicating Push Button.—A push button which leaves an indication of its having been depressed.

Indicating Switch.—A switch provided with an indicator which shows whether the circuit of the switch is closed or open.

Indicator.—A term sometimes employed for annunciator.

Indicator Card.—The card of a steam-engine indicator, on which are traced the curves of pressure, by means of which the indicated horse-power of the engine may be calculated.

Indicator Dial, Electric.—In a system of railway block signalling by electricity, an electro-magnetic indicator having a dial which shows the condition of a section of railway.

Indicator, Electric.—(1) A general term

- applied to various devices operated by the deflection of a magnetic needle, or the ringing of a bell, or by both, for indicating, at some distant point, the condition of an electric circuit, the strength of current passing through any circuit, the head of water or other liquid, the pressure on a boiler, the temperature, the speed of an engine or lines of shafting, the working of a machine, or other similar events or occurrences. (2) A term sometimes used in place of annunciator. (3) Any electric or magnetic signalling apparatus.
- Indicator Flap.**—A light metal disk or cover, hinged over a self-restoring indicator, in a branching multiple telephone switchboard.
- Indifferent Electrode.**—In electro-therapeutics, the electrode that is employed to merely complete the circuit through the organ or part of the body subjected to the electric current, and not directly concerned in the treatment or diagnosis of the diseased part, and which, therefore, may be located at any convenient point.
- Indifferent Point.**—A point in the intrapolar regions of a nerve, where the anelectrotonic and cathelectrotonic regions meet, and where the excitability is, therefore, unchanged.
- Indirect Distribution.**—A system of electric distribution in which intermediate contrivances for the transformation or accumulation of electric energy are employed between the generator and the receptive devices.
- Indirect Electrolysis.**—Chemical reactions effected as a consequence of electrolytic action, as distinguished from electrolytic actions themselves.
- Indirect Excitation.**—The excitation of a muscle obtained by placing an electrode on its nerve instead of directly on the muscle.
- Indirect Welder.**—A step-down transformer employed in electric welding.
- Individual Electric Motors.**—A term sometimes employed for electric motors that are coupled directly to the shaft of each machine to be driven or operated.
- Individual Signal.**—A selective signal, or one in which a given signal only is sounded at a distant point on a circuit with which more than one signal is connected.
- Individual Signalling Apparatus.**—Signalling apparatus provided with individual signals.
- Individual Telephone Switchboard.**—A single section of a multiple switchboard.
- Individual Transformer.**—A transformer employed solely for the supply of some particular translating device or group of devices, as distinguished from a transformer which supplies a number of circuits or groups.
- “In-Door” Transformer.**—A transformer designed for use inside a building.
- Induced.**—(1) Set up or caused by induction. (2) Not produced by metallic communication.
- Induced Atomic or Molecular Currents.**—Currents supposed to be induced in the atoms or molecules of a magnetizable substance when brought into magnetic flux.
- Induced Circuit.**—An inductive circuit.
- Induced Current.**—A current produced by electro-dynamic induction.
- Induced Current of Transformer.**—A term sometimes employed for the secondary current of a transformer.
- Induced Direct-Current.**—(1) The current produced in an active circuit on the breaking of such circuit, having the same direction as the active current and tending to prolong and strengthen it. (2) The break-induced current.
- Induced Electromotive Forces.**—E. M. F.'s set up by electro-dynamic induction.
- Induced Electric Surging.**—Electric surging induced in neighboring conductors by means of electric surging, oscillatory discharges, or impulsive current-rushes in their vicinity.
- Induced Electrostatic Charge.**—A charge produced by bringing a body into an electrostatic field.
- Induced Lightning Discharge.**—(1) A lightning discharge produced in a substance by induction from a neighboring lightning flash. (2) A back or return lightning stroke.
- Induced M. M. F.**—(1) Any magneto-motive force produced by induction. (2) The aligned or structural magneto-motive force, as distinguished from the prime magneto-motive force.
- Induced Magnetic Flux.**—Magnetic flux produced in any body by induction.
- Induced Reverse Currents.**—(1) The currents induced in an active conductor at the moment of making or closing the circuit in the opposite direction to the inducing current, and, therefore, tending to check its flow. (2) The current induced in the secondary on making or breaking the circuit of the primary.

Induced Spiral or Conductor.—A term sometimes used for the secondary spiral or conductor of a transformer.

Inducing.—Producing electromotive forces, currents, or fluxes, by means of induction.

Inducing Circuit.—Any circuit which causes induction.

Inducing Current of Transformer.—A term sometimes employed for the primary current of a transformer.

Inducing Magnet.—The permanent magnet of a relay.

Inducing Spiral or Conductor.—A term sometimes used for the primary spiral or conductor of a transformer.

Inductance.—(1) The capacity for induction possessed by an active circuit on itself, or on neighboring circuits. (2) Self-induction. (3) That property, in virtue of which a finite electromotive force impressed on a circuit does not immediately generate the full current due to the resistance of the circuit, and which, when the electromotive force is withdrawn, requires a finite time for the current strength to fall to its zero value. (4) A property, by virtue of which the passage of an electric current is necessarily accompanied by the absorption of electric energy in producing a magnetic field. (5) A constant quantity in a circuit at rest, and devoid of iron, depending only upon its geometrical arrangement, and usually expressed in henrys, or in centimetres.

Inductance Box.—A box containing a number of graded inductances, and employed for the measurement of the inductance of a circuit.

Inductance Bridge.—An apparatus similar to a Wheatstone's bridge, for measuring the inductance of a circuit.

Inductance Coil.—(1) An impedance, reactance, or choking coil. (2) A coil placed in a circuit, for the purpose of preventing an impulsive current-rush in that circuit, by means of the counter-electromotive force developed in the coil on being magnetized.

Inductance-Reactance.—The reactance of a self-inductive coil, as distinguished from the reactance of a condenser, or a capacity-reactance.

Inductance-Resistance.—Reactance.

Inductance Speed.—(1) A term proposed for the product of the co-efficient of self-induction by an angular velocity, corresponding to a simple-harmonic frequency. (2) In an alternating-current circuit, the

product of an inductance and 2π times the frequency.

Inductanceless.—Devoid of inductance.

Inductanceless Circuit.—(1) A circuit practically devoid of inductance. (2) A circuit whose magnetic field is negligible, such, for example, as an ordinary incandescent lamp, or a double-wound resistance coil.

Inducteous Body.—A term proposed by Faraday for a body in which a charge is induced by the action of a neighboring charge.

Induction.—(1) The influence exerted by a charged body, or by a magnetic field, on neighboring bodies without apparent communication. (2) The influence produced through a dielectric by the action of electrostatic or magnetic flux.

Induction Alternator.—A name sometimes given to an inductor alternator.

Induction Booster.—An ordinary induction motor whose field coils are in series with the mains, employed in an alternating-current circuit as a booster or feeder regulator.

Induction Bridge.—(1) A balance in which electro-magnetically induced currents are equilibrated. (2) An inductance bridge.

Induction Coil.—An apparatus consisting of two associated coils of insulated wire employed for the production of currents by mutual induction.

Induction Factor.—In an alternating-current circuit the ratio of the wattless component of current to the total current strength.

Induction-Finder.—A term sometimes used for a magnetic explorer.

Induction Flux.—Total magnetic flux in any portion of a magnetic circuit.

Induction Generator.—(1) A generator supplying currents which are received from the line and reinforced within its coils. (2) A generator which operates by induction from currents in a short-circuited armature. (3) An induction-motor driven above synchronism. (4) An alternating-current dynamo itself incapable of generating currents but becoming excited by currents received from the line.

Induction Killer.—Any anti-induction device.

Induction Motor.—(1) An asynchronous alternating-current motor, in which currents are induced in a short-circuited element or armature. (2) A polyphase or uniphase motor operating by the action

of a rotary magnetic field upon a short-circuited armature.

Induction Multiphase-Motor.—An alternating-current induction, or asynchronous motor, operated by multiphase currents.

Induction Plates of Condenser.—The metallic plates of a condenser on which the charges reside.

Induction Regulator.—A term sometimes employed for an alternating-current regulator.

Induction Resistance.—An inductive resistance.

Induction Rotary.—A term sometimes employed for a rotary converter without field excitation.

Induction Screen.—(1) A plate of metal placed between two adjacent electrified bodies, or magnetic coils, for the purpose of preventing or modifying the inductive action they exert on one another. (2) A conducting screen wholly or partially opaque to inductive action.

Induction Telegraph.—A general term embracing the apparatus employed in induction telegraphy.

Induction Telegraphy.—(1) A system for telegraphing, between moving trains and fixed stations on a railroad, by means of impulses transmitted by induction between the car and a wire parallel with the track. (2) Wireless telegraphy.

Induction Top.—A top consisting of a copper disc supported on a vertical axis, which, when spun before the poles of a steel magnet, assumes an inclined position, by reason of the currents produced therein.

Inductional Igniting Device.—A device for producing ignition by an induced electric discharge.

Inductionless.—Devoid of induction.

Inductionless Circuit.—A circuit devoid of induction.

Inductionless Resistance.—(1) A resistance devoid of self-induction. (2) A double-wound resistance.

Inductive.—Capable of producing induction.

Inductive Capacity of Line.—The electrostatic capacity of a line.

Inductive Circuit.—Any circuit in which induction occurs.

Inductive Connection.—A connection of one circuit with another by means of induction only, as distinguished from metallic connection.

Inductive Disturbance.—Any disturb-

ance in the operation of a telephone or telegraph line produced by induction.

Inductive Electromotive Force.—An electromotive force produced by induction.

Inductive Interference.—Inductive disturbance on a line.

Inductive Leak.—A leak containing inductance provided in a cable or circuit as distinguished from a leak containing resistance only.

Inductive Leakance.—(1) Leakage taking place through inductive shunts. (2) Leakage artificially produced in a telegraph or telephone circuit through induction coils.

Inductive Pole.—An induced pole.

Inductive-Reactance.—Reactance due to self induction as distinguished from reactance due to a condenser.

Inductive Retardation.—A retardation in the appearance of a signal, at the distant end of a cable or circuit, produced by the action of induction.

Inductive Resistance.—(1) A resistance possessing self-induction. (2) The reactance of a circuit.

Inductive Resistance Regulator.—Any regulator suitable for altering the impedance of a circuit or conductor by varying its inductance.

Inductivity.—(1) A word proposed for specific inductance. (2) Magnetic permeability.

Inductivity.—(1) The magnetic permeability of a magnetic medium. (2) The dielectric constant of an electric medium.

Inductively Associated Circuit.—Such a position of a circuit as regards another circuit, that any electric change in one circuit produces a corresponding change in the other circuit by induction.

Inductize.—To subject a body to the effects of induction.

Inductometer.—An instrument capable of measuring inductance.

Inductophone.—A device for obtaining electric communication between moving trains and fixed stations by means of induction currents.

Inductor Alternator.—(1) An inductor dynamo for alternating currents. (2) An alternator in which both armature and field are fixed, but in which a rotating frame is so placed in relation to each as to generate E. M. F.'s in conducting loops or coils on the armature.

Inductor Alternating Generator.—An alternator in which neither the field coils

- nor the armature rotates, but an iron frame rotates in such a manner as to periodically fill and empty the armature loops with magnetic flux.
- Inductor Dynamo.**—(1) A generator in which the field and armature coils are stationary, and the magnetic flux through them is altered by the motion of inductors past them. (2) A dynamo-electric generator in which the differences of potential causing the currents are obtained by magnetic changes in the cores of the armature and field coils by the movements of inductors past them.
- Inductor Generators.**—Inductor alternators or dynamos.
- Inductors of Electrostatic Machine.**—The electrified parts of an electrostatic influence machine, which exert inductive influence.
- Inductors.**—The laminated masses of iron employed in inductor dynamos for the purpose of producing variations in the magnetic flux of the core and armature.
- Inductorium.**—A name sometimes given to an induction coil.
- Inductoscope.**—Any apparatus for detecting the presence of induction between two circuits.
- Inductive.**—Capable of producing induction.
- Inductive Body.**—A term proposed by Faraday for the body containing the inducing electric charge.
- Inefficiency of Incandescent Lamp.**—The number of watts that have to be supplied to an incandescent lamp per-candle-power emitted, very commonly, but inaccurately, called the efficiency of the lamp.
- Inertia.**—The inability of a body to change its condition of rest or motion until some force acts on it.
- Inertia, Electric.**—A term sometimes used for electro-magnetic inertia.
- Inertia Factor.**—The factor in a dynamical system in virtue of which the moving system possesses kinetic energy.
- Inferred Zero.**—(1) A zero deduced or inferred from the deflection produced by a charge that is to be measured, by comparison with the value of the deflection obtained by a known charge. (2) A zero on the scale of an instrument, too remote to be mechanically obtainable, but assumed as virtually existing for the purposes of calculation.
- Infinity Plug.**—(1) A plug provided for a hole in a resistance box in which the two pieces of brass the plug connects are not connected by any resistance coil, and which, therefore, when withdrawn, leaves an open circuit of a practically infinite resistance. (2) A discontinuity plug.
- Inflection.**—The bending by diffraction of rays of light or radiant energy on their passage past a sharp edge.
- Inflexible Conduit System.**—A conduit system which will not permit the introduction or removal of its conductors; after the structure is completed.
- Influence.**—A word sometimes used instead of electrostatic induction.
- Influence Charge.**—A charge produced by electrostatic induction.
- Influence, Electric.**—Electrostatic induction.
- Influence Machine.**—A name sometimes used for an electrostatic-induction machine.
- Infra-Red Frequencies.**—Frequencies lower or smaller in number than those of red light.
- Infra-Red Light.**—A term applied to radiation frequencies below the reds of the spectrum.
- Infra-Red Spectrum.**—That portion of the spectrum which lies below the red, or whose frequencies are smaller than those of the red.
- Initial.**—Placed or occurring at the beginning.
- Initial Magnetization.**—Magnetization originally produced or imparted.
- Injection of Telegraph Poles.**—Impregnating telegraph poles with any preservative liquid.
- Injector.**—An apparatus for the introduction of a condenser or other device into an electric circuit at a definite moment and for a definite interval of time.
- Inners.**—In telephony, the internal pair of springs of a jack.
- In-Put.**—The power absorbed by any machine in causing it to perform a certain amount of work.
- Inside Box-Brush.**—A brush suitably shaped for polishing the inside of tubular surfaces, for the purpose of cleansing such surfaces so as to prepare them for electroplating.
- Inside Wiring.**—(1) In a system of incandescent lighting, the conductors that lead to the interior of a house or other building to be lighted. (2) Any conductors placed inside a building.
- Inside Work.**—Indoor wiring.
- Insulation, Electric.**—A term sometimes employed for electric sun-stroke or electric prostration.

Inspection Boxes.—Man-holes provided for the inspection of electric mains.

Installation.—(1) A general term embracing the entire plant and accessories required to perform any specified work. (2) The act of placing, arranging or erecting a plant or apparatus.

Installation, Electric.—(1) The establishment of any electric plant. (2) A plant.

Instantaneous.—Occurring at an instant.

Instantaneous-Contact Method.—A method of determining the form of an alternating-current wave by making contacts with the circuit at definite instants in each cycle.

Instantaneous Current.—The current strength taken at any given moment of time.

Instantaneous Electromotive Force.—The value of the electromotive force taken at any given instant of time.

Instantaneous Efficiency of Transformer.—The efficiency of a transformer taken at any instant of time, as distinguished from its mean efficiency, or its efficiency extending over a fairly considerable time.

Instantaneous Pressure.—The instantaneous electromotive force.

Instantaneous Value of Periodic Current or E. M. F.—The value of a periodic current or E. M. F. at any given instant of time as distinguished from an average or effective value.

Instantaneous Values.—Values measured at a given instant of time, as distinguished from average values.

Instrument Bars.—In a multiple telephone switchboard the conducting bars connected to an operator's set.

Instrument Zero.—The true zero of an instrument scale, as distinguished from a zero selected at some other point or a false zero.

Insulate.—To so insulate a body as to prevent electricity from being conducted to or removed from it.

Insulated Body.—A body supported on or surrounded by an insulator, or non-conductor of electricity.

Insulated Conductors.—Conducting wires provided with an insulating coating or covering.

Insulated.—A term sometimes employed in telegraphy for a free wire, or a wire that is disconnected from its apparatus and left insulated.

Insulated Pliers.—A pair of pliers whose

handles are encased in insulating material.

Insulated Trolley-Crossing.—A crossing placed at the intersection of two streets where trolley wires cross each other, provided with an insulating material to prevent the contact of the crossing wires.

Insulated Turn-Buckle.—(1) A turn-buckle carrying a shackle insulator at one end. (2) A device supported by suitable insulators employed on overhead circuits for straightening the wires by increasing the stress on them.

Insulated Wires.—Wires provided with insulating coverings or coatings.

Insulating.—Providing with insulation.

Insulating Bushing.—A bushing made of insulating material.

Insulating Cements.—Various mixtures of gums, resins and other substances possessing the ability not only of binding two or more substances together, but also of electrically insulating them from one another.

Insulating Coating.—A coating or covering of insulating material.

Insulating Covering.—An insulating coating.

Insulating Joint.—A joint in an insulating material or covering in which the continuity of the insulating material is ensured.

Insulating Sleeve.—A sleeve formed of insulating material, and provided for covering splices in an insulated conductor.

Insulating Stool.—A stool provided with insulating supports of vulcanite, or similar high-insulating substance, employed to afford a convenient insulating stand or support.

Insulating Tape.—A ribbon of flexible material impregnated with okonite, rubber, or other similar material, and generally containing some adhesive substance, employed for insulating wires or electric conductors at joints, or other exposed places.

Insulating Tube.—(1) A tube of insulating material provided for covering a splice in an insulated conductor. (2) A tube of insulating material provided for slipping over an insulated conductor where it passes through a partition, and employed for preventing the abrasion of the insulating material at that point.

Insulating Varnish.—An electric varnish formed of any good insulating material.

Insulating Washer.—A washer formed of insulating material.

Insulation.—Any medium or material that will prevent a body from gaining or losing light, heat, electricity, etc.

Insulation Bracket.—A bracket of insulating material, provided with an insulator.

Insulation Break-Down.—Any failure of the insulation which prevents it from insulating.

Insulation, Electric.—A non-conducting material so placed with respect to a conductor as to prevent either the loss of its charge, or the leakage of its current.

Insulation Joint.—A joint in an insulating material or covering in which continuity is preserved both in the conducting and in the insulating substance.

Insulation Lightning-Protection.—The protection of an instrument by means of an insulating lightning-protector from the jumping of a spark across it from layer to layer.

Insulation Lightning-Protector.—A lightning protector by means of which a discharge is prevented from jumping across the coils of an instrument from layer to layer, and thus damaging its insulation.

Insulation Materials.—(1) Materials whose resistivity is high. (2) Non-conductors.

Insulation Resistance.—(1) The resistance existing between a conductor and the earth, or between two conductors in a circuit through insulating materials lying between them. (2) The resistance taken between a line or conductor and the earth through the insulators, or between two separate wires of a cable through the insulating materials separating them. (3) A term sometimes applied to the resistance of the insulating material of a covered wire or conductor. (4) The resistance of any insulation.

Insulator.—Any device employed for insulating a wire or other body.

Insulator Bracket.—A frame of wood or metal for holding the insulator of an overhead wire, and of such simple form as to be readily attached to a wall or support.

Insulator Cap.—A cover or cap placed some distance above an insulator, but separated from it by an air space.

Insulator Pin.—The bolt by which an insulator is attached to a bracket, pole-arm, or support.

Intaglio.—(1) An engraving in which the

surface is so hollowed out that an impression therefrom would give the appearance of a bas-relief. (2) The copy of a coin or other similar object obtained in an electro.

Intake.—A word sometimes used instead of input.

Intake of Dynamo.—The mechanical activity which a dynamo absorbs when running.

Intake of Machine.—The activity required to operate a machine.

Intake Wires.—The wires which feed a distribution box.

Integrating Meter.—Any meter which leaves a record of, and sums up, or integrates, some quantity with respect to time.

Integrating Wattmeter.—(1) A watt-hour meter, or a meter which integrates the power which passes through it with respect to time. (2) An energy meter.

Integrator.—An apparatus for automatically performing the operation of integration, or the continuous summing up of instantaneous values.

Intensity.—(1) The surface density of a vector or directed quantity. (2) The degree of concentration with which a number of forces act.

Intensity Armature.—A term formerly employed for an armature with coils of many turns, and, consequently, of a comparatively high resistance. (Obsolete.)

Intensity Current.—A term formerly employed for the current produced by a series-connected battery. (Obsolete.)

Intensity of Current.—(1) A term taken from the French language to indicate current strength. (2) Current density, or current strength per-unit-area of normal cross-section.

Intensity of Field.—The strength or density of a magnetic field as measured by the quantity of magnetic flux that passes through it per-unit-of-area of normal cross-section.

Intensity of Illumination.—The quantity of light received per-unit-of-surface.

Intensity of Light.—(1) In a given direction of emission, the ratio of the flux of light in a small solid angle containing that direction to the solid angle. (2) The candle-power of a light.

Intensity of Magnetic Flux.—(1) The quantity of magnetic flux per-unit-of-area of normal cross-section. (2) The density of magnetic flux.

Intensity of Magnetization.—(1) A

quantity which represents the intensity of magnetization produced in a substance. (2) A quantity which represents the intensity with which a magnetizable substance is magnetized. (3) Magnetic moment per-unit-volume. (4) The surface density of imaginary magnetic matter on any surface normal to the direction of magnetization.

Intensity of Radiation.—(1) The ratio existing between the amount or quantity of radiation, and the surface from which that radiation takes place. (2) The ratio of the flux of energy in any small solid angle of a beam to the solid angle.

Interactance.—In an induction coil operated on a simple alternating-current circuit, the product of the mutual inductance and the angular velocity corresponding to the frequency of the current, and expressible in ohms.

Inter Air-Space.—A term sometimes employed for the air-space or entrefer.

Inter-Atomic Ether.—A term sometimes used for the ether existing between the constituent atoms of the molecules.

Inter-Connected Armature-Winding. (1) Such a connection of the separate circuits in a multipolar armature as will permit a single pair of brushes to be employed on the commutator. (2) A cross-connected armature.

Inter-Connection.—The cross-connection of an armature.

Inter-Crossing.—In a system of telephonic circuits, a device for avoiding the disturbing effects of induction, by alternately crossing equal sections of the line wires.

Inter-Exchange Working.—(1) Telephonic communication effected through the medium of more than a single exchange. (2) Telephone communication passing between two exchanges, or between two subscribers connected therewith.

Interference of Electro-Magnetic Waves.—Interference effects, similar to those produced in the case of light and sound, observed in electro-magnetic waves when two systems of waves of equal frequency simultaneously act, in opposed phases, on the same medium.

Inter-Ferric Gap.—(1) An air-gap in an æro-ferric magnetic circuit between iron and iron. (2) The entrefer.

Inter-Ferric Space.—An inter-ferric gap.
Interflange.—The distance between the two flanges of a bobbin, measured parallel to the bobbin's axis, and represent-

ing the length of the cylindrical space which may be occupied by wire when the bobbin is wound.

Inter-Induction.—Mutual induction.

Interior Conduit.—(1) A conduit provided inside the walls of a house, or in other convenient spaces within a house, for the reception of the house wires. (2) A conduit in the walls or floors of a building, provided for accommodating electric conductors.

Interior-Conduit Junction-Box.—The box provided in a system of interior conduits to receive the terminals of the feeders, and in which connection is made between the feeders and the mains, or the mains and branches.

Interior-Pole Dynamo.—A dynamo having field poles in the interior of a cylindrical or Gramme-ring armature.

Inter-Linked Diphas-System.—A three-wire diphas-system.

Inter-Linked Polyphase-System.—A polyphase system of conductors so interconnected that one wire serves as the return for another, and distinguished from a polyphase system in which each phase is provided with a separate circuit.

Inter-Locking Apparatus.—A device for mechanically operating railroad switches and semaphoric signals from a distant signalling tower, for the purpose of indicating the position of such switches, by means of a system of inter-locking levers, so inter-locked as to render it impossible, after a route has once been set and a signal given, to clear a signal for a route that would conflict with the one previously set up.

Inter-Locking Magnet.—A magnet employed in a system of electric railroad signals for crossings, whereby a gong is caused to ring at the crossings on the approach of a train, and is automatically stopped by the same train after it has passed the crossing.

Intermediate Cable.—A type of cable intermediate between a shore-end cable and a deep-sea cable.

Intermediate Station.—Any station between the terminal stations of a telegraph line.

Intermediate Switch.—A switch employed at an intermediate telephone station for communicating with either terminal station at will, without interrupting the line.

Intermittent.—(1) Acting at intervals only. (2) Fluctuating or pulsating.

Intermittent Contact.—The occasional contact of a telegraphic or other line with other wires or conductors, by swinging, or by alternate contractions and expansions, occasioned by changes of temperature.

Intermittent Cross.—(1) An accidental contact, generally metallic, occasioned by wires being brought into occasional contact with one another, or with some other conductor by the intermittent action of the wind. (2) A swinging cross.

Intermittent Current.—A current that does not flow continuously, but which flows and ceases to flow at intervals, so that electricity is practically alternately present and absent from the circuit.

Intermittent Currents of Wheatstone System.—In the Wheatstone automatic system the transmission of short initial and final currents in each signal.

Intermittent Disconnection.—Any fault in a line which occurs at intervals or intermittently.

Intermittent Electromotive Force.—An electromotive force which acts intermittently.

Intermittent Earth.—(1) A fault in a telegraphic or other line in which, by the action of the wind, or by occasional expansion by heat, the line is brought into intermittent contact with the earth. (2) A swinging earth.

Intermittent Integrating Meter.—A meter which does not take a reading of the current or power continuously, but at regular intervals, and then adds up the result.

Intermittent System of Currents.—A system of currents employed in telegraphy, in which the initial and final currents are separated by an interval or insulation.

Interrupter.—An interrupter.

Inter-Molecular.—Between the molecules.

Inter-Molecular Ether.—A term sometimes used for the ether that exists between the molecules of matter.

Internal Armature Generator.—A generator in which the armature is situated within the field-poles, as distinguished from a generator whose armature is external to the field.

Internal Characteristic of Dynamo.—A curve showing the E. M. F. generated in a dynamo under varying excitation, as distinguished from the external characteristic showing the E. M. F. at terminals.

Internal Circuit.—That part of a circuit which is included within the electric source.

Internal Magnetic-Circuit.—A term sometimes employed for that part of a magnetic circuit which lies within the magnetic core.

Internal Magnetic-Field.—That portion of a magnetic field produced by a magnet which lies within the magnetic core.

Internal Polarization of Moist Body.—A polarization exhibited by such moist bodies as nervous or muscular fibres, the juicy parts of vegetables and animals, or in general, by all bodies possessing a firm structure and filled with a liquid, on the passage through them of a strong electric current.

Internal Poles of Dynamo.—(1) The inwardly projecting field poles of a dynamo. (2) Magnetic field-poles internal to an armature.

International Ampere.—(1) The value of the ampere as adopted by the International Congress of 1893, at Chicago. (2) The value of an ampere equal to the one-tenth of a unit of current in the C. G. S. system of electro-magnetic units, and represented with sufficient accuracy for practical purposes, by the unvarying current, which, when passed through a solution of nitrate of silver in water, in accordance with certain specifications, deposits silver at the rate of 0.001118 of a gramme-per-second.

International Coulomb.—(1) The value of the coulomb as adopted by the International Electrical Congress of 1893, at Chicago. (2) The quantity of electricity equal to that transferred through a circuit by a current of one International ampere in one second.

International Farad.—(1) The value of the farad as adopted by the International Electrical Congress of 1893, at Chicago. (2) The capacity of a conductor charged to a potential of one International volt by one International coulomb of electricity.

International Henry.—(1) The value of the henry as adopted by the International Electrical Congress of 1893, at Chicago. (2) The value of the induction in a circuit, when the electromotive force induced in the circuit is one International volt, and the inducing current varies at the rate of one ampere per second.

International Joule.—(1) The value of the joule as adopted by the International Electrical Congress of 1893, at Chicago. (2) A value equal to 10^7 units of work of

the C. G. S. system and represented with sufficient accuracy for practical purposes by the energy expended in one second by one ampere in one International ohm.

International Morse Code.—A term sometimes employed for the International telegraphic alphabet, as distinguished from the American Morse Code.

International Ohm.—(1) The value of the ohm as adopted by the International Electrical Congress of 1893, at Chicago.

(2) A value of the ohm equal to 10^9 units of resistance of the C. G. S. system of electro-magnetic units, and represented by the resistance offered to an unvarying electric current by a column of mercury at the temperature of melting ice, 14.4521 grammes in mass, of a constant cross-sectional area, and of the length of 106.3 centimetres.

International Telegraphic Code.—The International Morse Code.

International Unit of Activity.—The International watt.

International Unit of Work.—The International joule.

International Volt.—(1) The value of the volt as adopted by the International Electrical Congress of 1893, at Chicago.

(2) Such an electromotive force that steadily applied to a conductor whose resistance is one International ohm, will produce a current of one International ampere, and which is represented with sufficient accuracy for practical use by $\frac{1000}{1434}$ of the electromotive force between the poles or electrodes of the voltaic cell known as Clark's cell, at a temperature of 15° Cent. when prepared in accordance with certain specifications.

International Watt.—(1) The value of the watt as adopted by the International Electrical Congress of 1893, at Chicago.

(2) A value equal to 10^7 units of activity in the C. G. S. system, and equal to the work done at the rate of one joule-per-second.

Inter-Node.—The space between two adjacent nodes.

Inter-Polar.—Between the poles.

Inter-Polar Gap.—An air-gap or space between the faces of opposing pole-pieces.

Inter-Polar Space.—The inter-polar gap.

Interpolated Commutator Segments.—Blank commutator segments.

Interrupted.—Broken or opened.

Interrupted Current System.—A system of electric distribution effected by the aid of periodically interrupted continuous currents.

Interrupter.—Any device for interrupting or breaking a circuit.

Inter-Urban Communication.—Telegraphic or telephonic communication between adjacent cities.

Inter-Urban Electric Railway.—An electric railway suitable for use between adjacent cities.

Inter-Urban Telephony.—Telephonic communication carried on between adjacent cities.

Intra-Molecular.—(1) Inter-molecular, or between the molecules. (2) Within the confines of a molecule.

Intra-Polar Electrolysis.—Electrolytic action taking place in the region between the electrodes, as distinguished from that which occurs in their immediate vicinity.

Intrinsic Brilliancy of Luminous Source.—(1) At any point of a luminous surface the ratio of the luminous intensity along the normal to the small surface area from which it is emitted. (2) Luminous intensity per-unit-area of normal luminous surface.

Intrinsic Electrization.—A term proposed for permanent impressed electrization in a substance from internal causes.

Intrinsic Intensity of Light.—The quantity or flux of light emitted normally from a unit of surface of a luminous source.

Intrinsic Magnetization.—Magnetization due to impressed magnetic force, as distinguished from magnetization due to electric currents.

Intrinsic Radiation of Luminous Source.—(1) The radiation of a luminous source expressed in lumens-per-square-centimetre. (2) The flux density of light issuing normally from a luminous source.

Invariable Calibration of Galvanometer.—In a galvanometer with absolute calibration, a method for preventing the occurrence of variations in the intensity of the field of a galvanometer, due to the neighborhood of masses of iron.

Inverse Current.—(1) The current which tends to be produced by a current in its own circuit on making or closing the circuit. (2) The current produced in the secondary of an induction coil on the making or completion of the circuit of the primary. (3) The make-induced current.

Inverse Electromotive Force.—An electromotive force which acts in the opposite direction to another already existing electromotive force.

Inverse Secondary Current.—The make-induced current.

- Inversion, Electric.**—The determination of electric distribution over the surfaces of neighboring electrified conductors by the geometrical method of inversion.
- Invert Insulator.**—An insulator supported in an inverted position.
- Inverted Arc.**—An inverted arc-lamp.
- Inverted Arc-Lamp.**—An electric arc-lamp in which the positive carbon is lowermost, or inverted, as compared with its position in the ordinary arc-lamp.
- Inverted Dynamo.**—A dynamo whose armature bore or chamber is placed below the field-magnet coils.
- Inverted Induction-Coil.**—A term sometimes employed for a step-down transformer.
- Invisible Electric-Contact Matting.**—A matting or other floor covering, provided with a series of invisible electric contacts, which are closed by a person walking over them.
- Invisible Spectrum.**—That portion of the spectrum which is incapable of affecting the eye as light.
- Ionic.**—Of or pertaining to the ions.
- Ions.**—The groups of atoms or radicals into which a molecule is separated by electrolytic decomposition.
- Ionic Attraction.**—The mutual attraction produced by the cations and the anions.
- Ionic Conductivities.**—Specific conductivities of ions, so selected that their sums give molecular conductivities for any combination of ions.
- Ionisation.**—(1) The decrease in the strength with which the separate atoms or radicals are held together in the molecules of an electrolyte. (2) A modified dissociation of the molecule of an electrolyte which consists in the weakening of the force which holds together its ions or radicals.
- Iron-Armored Conduit.**—(1) A conduit provided with an exterior iron casing or covering. (2) A conduit in which each duct has an iron casing or covering.
- Iron-Clad.**—Surrounded by iron.
- Iron-Clad Armature.**—(1) The armature of a dynamo or motor, whose insulated coils are entirely or nearly surrounded by the iron of the armature core. (2) An armature in which the conductors are buried in slots, grooves, or tunnels below the surface of the armature core.
- Iron-Clad Armature Windings.**—Armature windings that are entirely or nearly surrounded by iron.
- Iron-Clad Coil.**—An iron-clad magnet.
- Iron - Clad Drop.**—An annunciator or telephone drop whose electro-magnet is iron-clad.
- Iron-Clad Dynamo.**—(1) A dynamo whose armature is iron-clad. (2) An iron-encased dynamo.
- Iron-Clad Electro-Magnet.**—An electro-magnet whose magnetizing coil is almost entirely surrounded by iron—in some cases to increase its portative power, in others to increase its inductance, and in yet others to shield its magnetic variations.
- Iron-Clad Generator.**—An iron-clad dynamo.
- Iron-Clad Inductance.**—An inductance associated with a ferric or ferro-ferric magnetic circuit, as distinguished from an inductance associated with a non-ferric magnetic circuit.
- Iron-Clad Magnet.**—(1) An electro-magnet whose magnetic resistance is lowered by a casing of iron connected with the core, and provided for the passage of the magnetic flux. (2) An iron-clad electro-magnet.
- Iron-Clad Motor.**—A motor whose armature is iron-clad. (2) An iron-encased motor.
- Iron-Clad Rheostat.**—A rheostat whose resistance coils are provided with an enamelled insulation, and imbedded in a mass of iron.
- Iron Core.**—The mass of iron on which are placed the magnetizing coils of an electro-magnet or solenoid.
- Iron-Core Loss.**—The hysteretic and Foucault losses due to the presence of an iron core.
- Iron Covered Cable.**—A submarine cable provided with an iron sheathing.
- Iron-Enclosed Electro-Magnet.**—An iron-clad electro-magnet.
- Iron-Loss in Transformer.**—The loss of energy in a transformer due both to magnetic hysteresis or magnetic friction, and to the setting up of eddy or Foucault currents in the iron.
- Iron Magnetic Circuit.**—A ferric magnetic circuit.
- Iron Reluctance.**—(1) The reluctance in a magnetic circuit due to the presence of iron in that circuit. (2) Reluctance in iron.
- Iron-Work Fault of Dynamo.**—A ground or connection between the circuit of a dynamo and any part of its iron frame.

Irrationality of Dispersion.—A lack of proportionality in the dispersions of spectra produced by different refractive media.

Irreciprocal Conduction.—(1) Conduction in which the magnitude of the current is altered when its direction is reversed. (2) The electric conduction in an asymmetrical resistance.

Irregular Magnetic Flux.—Magnetic flux which is not uniform, but is either converging or diverging, as distinguished from uniform magnetic flux.

Irregular Variation.—Any variation of the magnetic needle which occurs at irregular intervals.

Irreversible Heat.—(1) Heat produced in a homogeneous conductor by the passage of electricity through it in any direction. (2) In an electric circuit, the joulean heating effect as distinguished from the Peltier effect. (3) In an electric circuit any development of heat by the current, which does not depend upon its direction.

Iridescence.—Interference effects producing rainbow-colored tints by the refraction of light from thin, transparent, finely striated surfaces.

Irritability, Electric.—The irritability of nerves or muscles produced by an electric current or discharge.

Irrotational Stress.—(1) Stress unaccompanied by rotation. (2) A stress devoid of curl.

Isobaric Lines.—Isobars.

Isobarometric Lines.—The isobaric lines.

Isobars.—(1) Lines connecting places on the earth's surface which simultaneously have the same barometric pressure. (2) The isobaric lines.

Ischasmen Curves.—Curves drawn on the earth's surface between zones having equal frequency of auroral discharges.

Isochronism.—Equality of time-vibration or motion.

Isochronize.—To produce equality of time-vibration or motion.

Isochronizing.—Producing equality of time-vibration or motion.

Isochronous Oscillations.—Isochronous vibrations.

Isochronous Vibrations.—Vibrations or oscillations which perform their to-and-fro motions on either side of the position of rest in equal times.

Isoclinal.—Possessing the same inclination.

Isoclinal Lines.—Lines connecting places

on the earth's surface which have the same magnetic inclination or dip.

Isoclinal Chart.—A map or chart on which isoclinal lines are marked.

Isoclinic.—Of or pertaining to the isoclinals.

Isodynamic.—Possessing equal force.

Isodynamic Chart or Map.—A map or chart on which isodynamic lines are marked.

Isodynamic Lines.—Lines connecting places which have the same total magnetic intensity.

Iso-Electric Points.—A term sometimes used in electro-therapeutics for points of equal potential.

Isogonal.—Of or pertaining to the isogonal lines.

Isogonal Chart or Map.—A chart or map on which the isogonal lines are marked.

Isogonal Lines.—Lines connecting places on the earth's surface which have the same magnetic declination.

Isogonic.—Of or pertaining to the isogonic lines.

Isolated Electric Lighting.—Electric lighting in which the plant is located on the premises that are to be lighted, as distinguished from a plant located at a station, central either to a number of buildings, or to an extended area to be lighted.

Isolated Plant.—An electric plant or distribution system confined to a building or group of buildings as distinguished from a central-station system.

Isolated-Station Telephone Switchboard.—A switchboard established for the inter-communication of a number of telephons, where the distance separating them is considerable, or where privacy in the communication is essential. (2) A small sub-station telephone switchboard. (3) A domestic telephone switchboard.

Isolatine.—A variety of insulating material.

Isolating Switch for Lamps.—A short-circuiting switch designed to cut a lamp completely out of connection with a circuit and without opening or breaking the circuit of other lamps.

Isolux.—(1) A line connecting points of equal illumination on any illumined surface. (2) A line of equal illumination.

Isothermal Expansion of Gas.—The expansion of a gas whose temperature is maintained constant.

Isomorphism.—The quality of possessing the same crystalline form.

Isomerism.—A state or condition of compound substances which, though identical in composition, yet possess entirely different properties.

Isothermal Surfaces.—Surfaces on a body, all points of which have the same temperature.

Isothermals.—Lines connecting places on the earth's surface which have the same mean annual temperature.

Isotropic.—Possessing equal elasticity in all directions.

Isotropic Conductor.—(1) A substance which possesses the same powers of electric conduction in all directions. (2) An electrically homogeneous conducting medium.

Isotropic Dielectric.—A dielectric possessing the same powers of inductive capacity in all directions.

Isotropic Medium.—A medium possessing the same properties in all directions.

Isotropism.—The quality of possessing equal elasticity in all directions.

Isthmus Method of Magnetization.—A method of obtaining an exceedingly strong magnetization by so placing the body to be magnetized that it forms a narrow isthmus between the pole-pieces of a powerful electro-magnet.

Isynchronous Vibrations.—(1) Vibrations possessing equality of time of vibration or motion. (2) Isochronous vibrations.

J

J.—A contraction proposed for joule.

Jablochkoff Candle.—An electric arc light in which the two carbon electrodes are placed parallel to each other, and maintained at a constant distance apart by means of a strip of an insulating substance placed between them.

Jablochkoff's Igniter.—A small strip of carbon or carbonaceous material that is readily rendered incandescent by a current, placed between the free ends of the parallel carbons of a Jablochkoff candle, for the formation of an arc on the passage of the current.

Jack Hole.—In a telephone switchboard the hole leading into a jack.

Jack Panel.—The panel of a telephone switchboard provided for the support of the jacks.

Jack Switch.—A switch operated by means of a spring jack.

Jacketed Magnet.—A term sometimes applied to an iron-clad magnet.

Jacobi's Law.—The maximum activity is performed by an electric motor when its counter-electromotive force is equal to one-half of the impressed electromotive force.

Jacobi's Unit of Current.—Such a current that when passed through a voltmeter will liberate a cubic centimetre of oxygen and hydrogen per second at zero Cent., and 760 millimetres barometric pressure.

Jacobi's Unit of Resistance.—(1) The

electric resistance of 25 feet of a certain copper wire weighing 345 grains. (2) The resistance of a copper wire one metre in length and one millimetre in diameter of cross-section.

Jar, Electric.—A name formerly given to a Leyden jar.

Jar of Secondary Cell.—The jar in which the electrolyte and plates of a secondary cell are placed.

Jaws of Switch.—The metallic clips provided for the reception of the knife-blades of a switch.

Jet Photometer.—An apparatus for determining the candle-power of an illuminating gas by means of the height of a jet of such gas when burning under constant conditions of pressure and temperature.

Jewelry, Electric.—Minute incandescent lamps substituted for gems in articles of jewelry.

Jockey Gear.—The cable gear through which a cable has to pass when entering or leaving a picking-up or paying-out drum, and in which it passes under weighted wheels, called jockey wheels, for the purpose of maintaining a uniform tension of the cable upon the drum so as to prevent slip.

Jockey of Relay.—A form of extension tongue pivoted friction-tight upon the tongue of a sensitive relay employed in submarine telegraphy.

Jockey Wheel.—A weighted wheel riding over a cable on a grooved wheel in a

cable ship for the purpose of preserving uniformity of tension in the cable.

Joining-Up.—(1) Connecting in series or multiple-arc. (2) Generally, connecting or placing in a circuit.

Joining-Up a Wire.—Connecting a wire to an apparatus or circuit after it has been disconnected or grounded.

Joint.—(1) The junction of two or more pieces or conductors. (2) The place where the junction of two or more pieces or conductors is effected.

Joint Admittance.—The total or combined admittance of a number of separate admittances connected in parallel.

Joint Conductance.—The combined conductance of a number of separate conductances connected in parallel.

Joint-Cooling Tray.—A tray employed for cooling a cable core-joint by a cooling mixture.

Joint Magnetomotive Force.—The resultant magnetomotive force of a number of simultaneously acting magnetomotive forces.

Joint Reluctance.—The combined reluctance of a number of parallel-connected reluctances.

Joint Reluctivity.—The reluctivity of a number of parallel-connected reluctivities.

Joint Resistance.—The combined resistance of a number of parallel-connected resistances.

Joint Trough.—A trough of water or cooling solution in which a submarine cable joint is submerged for cooling.

Jointless Conductor.—A conductor in a single length and without joint.

Joulad.—A term proposed for joule. (Not in use.)

Joule.—(1) A volt-coulomb or unit of electric energy or work. (2) The amount of electric work required to raise the potential of one coulomb of electricity one volt. (3) Ten million ergs.

Joule Effect.—The heating effect produced by the passage of an electric current through a conductor, arising from its resistance only.

Joulean Effect.—A word sometimes used for joule effect.

Joule Meter.—(1) Any apparatus capable of measuring energy in joules. (2) An energy meter, as distinguished from a wattmeter.

Joule-Per-Second.—A unit of activity,

equal to the expenditure of one joule in each second.

Joule's Cylindrical Electro-Magnet.—An electro-magnet provided with a hollow cylindrical core.

Joule's Equivalent.—The mechanical equivalent of heat.

Joule's Law.—The heating power of a current is proportional to the product of the square of its strength and the resistance of the circuit through which it passes.

Journal.—That portion of a shaft which revolves on a bearing.

Journal Friction.—Friction produced by the rotation of a shaft on a bearing.

Jumper.—A temporary shunt or short circuit put around a source, lamp or receptive device on a series-connected circuit, to enable it to be readily removed or repaired.

Jump Spark.—A disruptive spark obtained between two opposed conducting surfaces, as distinguished from a spark obtained by or following a wiping contact.

Jump-Spark Burner.—A term sometimes applied to a gas burner in which the issuing jet is ignited by means of a high-tension spark obtained between two opposed points.

Junction.—In telephony, a wire or circuit connecting two exchanges.

Junction Board.—In telephony, a switchboard at which junction wires terminate.

Junction Box.—A moisture-proof box provided in a system of underground conductors to receive the terminals of the feeders, and in which connection is made between the feeders and the mains, and through which the current is distributed to the individual consumers.

Junction Calls.—Telephonic calls arriving on a junction line.

Junction Circuit.—In telephony, a line connecting a trunk circuit with a local subscriber.

Junction Line.—(1) In telephony, a junction. (2) A line connecting two telephone exchanges.

Junction-Line Plug.—In a central telephone exchange, a plug connected with a junction line.

Junction Lines.—Lines connecting two or more telephone exchanges, as distinguished from subscribers' lines.

Junction Operator.—In telephony, an operator at a junction board.

Junction Surface of Voltaic Cell.—The contact surface between the elements of a voltaic cell and the electrolyte.
Junction Wires.—Junction lines.

Junction Working.—Inter-exchange telephone working.

Just Non-Oscillatory Discharge.—A discharge which is just non-oscillatory.

K

K.—A symbol for electrostatic capacity.

K.—A symbol for moment of inertia.

κ.—A symbol for magnetic susceptibility.

K. C. C.—A contraction for cathodic closure contraction.

K. D. C.—A contraction for cathodic duration contraction.

K. W.—A contraction for kilowatt.

kg.—An abbreviation for kilogramme, a practical unit of mass.

kg : cm².—An abbreviation for kilogramme-per-square-centimetre, a practical unit of pressure.

kgm.—An abbreviation for kilogramme-metre, a practical unit of the moment of a couple or of work.

kgm : s.—An abbreviation proposed for kilogramme-metre-per-second, a practical unit of power.

KR.—A contraction for the total capacity of a telegraph or telephone wire or conductor, multiplied by its total resistance.

KR Law.—(1) A well-recognized law that the limiting speed of signalling through a submarine cable, assuming a given receiving and sending apparatus in uniform adjustment, varies inversely as the KR of the cable. (2) A generalization claimed as a law by some, but denied by most, which assigns the distance through which intelligible telephonic communication can be carried, to cases where the product of K, the capacity of the telephone circuit and R, its resistance, does not exceed a certain value.

Kaolin.—A variety of white clay sometimes employed for insulating purposes.

Kapp Lines.—A term proposed for unit lines of magnetic force or flux.

Karsten's Figures.—A name sometimes applied to electric breath figures.

Kartavert.—A variety of insulating material.

Katalysis.—An orthography sometimes employed for catalysis.

Kathelectrotonus.—Catelectrotonus.

Kathelectronic State.—The cathoelectronic state.

Kathelectrotonus Zone.—Cathoelectronic zone.

Kathelectrotonus.—Cathoelectrotonus.

Kathetometer.—A cathetometer.

Kathion.—A cathion.

Kathodal.—Cathodal.

Kathode.—A cathode.

Kathodic.—Cathodic.

Kathodic Electro-Diagnostic Reactions.—Cathodic electro-diagnostic reactions.

Kathodic Rays.—Cathodic rays.

Kations.—Cathions.

“Keeper” of Inductor Alternator.—A word sometimes employed for inductor.

Keeper of Magnet.—A mass of soft iron applied to the poles of a magnet, and through which its magnetic flux passes.

Kelvin.—(1) A word proposed, but not adopted, for a kilowatt-hour or one thousand watt hours. (2) A word proposed for the Board of Trade unit.

Kelvin Balance.—A form of electro-dynamometer balance designed by Lord Kelvin.

Kerite.—A variety of insulating material.

Kerite Tape.—A kerite-covered insulating tape.

Kerr Effect.—The elliptical polarization of a beam of plane polarized light, produced by its passage across an electrized dielectric.

Key-Board.—Any board to which electric keys or switches are connected.

Key-Board Transmitter.—The transmitter employed in a step-by-step or printing telegraph.

Key Lamp-Socket.—A lamp-socket provided with a key for lighting or extinguishing the lamp.

Keyless.—Devoid of a key.

Keyless Fire-Alarm Box.—A fire-alarm box covered with a glass window which requires to be broken in order to send the alarm.

Keyless Lamp-Socket.—A lamp-socket unprovided with a key, and whose lamp, therefore, requires to be lighted and extinguished by a switch placed elsewhere.

- Keyless Wall-Socket.**—A socket placed on a wall, provided for the reception of a plug switch for the introduction of a lamp.
- Kick.**—A recoil.
- Kick of Coil.**—The discharge from an electromagnetic coil.
- Kick of Relay.**—An impulse communicated to the tongue of a relay by a discharge from the line.
- Kicking Coil.**—A choking coil.
- Kicks.**—In telegraphy, sudden impulses of a mirror spot, or siphon, due to a momentary earth current or discharge.
- Kilerg.**—One thousand ergs.
- Killing Wire.**—(1) A method formerly adopted for removing kinks, bends and flaws in iron by stretching it on the line in long lengths. (2) A method of straightening wire by subjecting it to tension. (3) A term sometimes applied to loss of elasticity of contact springs of switches, due to their over-heating by the current.
- Kilo.**—A prefix for one thousand times.
- Kilo-Ampere.**—One thousand amperes.
- Kilo-Ampere Balance.**—A balance form of ammeter which measures thousands of amperes.
- Kilo-Dyne.**—One thousand dynes.
- Kilo-Erg.**—One thousand ergs.
- Kilo-Gauss.**—One thousand gausses.
- Kilogramme.**—One thousand grammes, or 2.2046 pounds avoirdupois.
- Kilogramme-Metre.**—A unit of work equal at Washington, D.C., to 9.81 multiplied by 10^7 ergs.
- Kilo-Henry.**—One thousand henrys.
- Kilo-Joule.**—One thousand joules.
- Kilo-Lines.**—One thousand lines of force.
- Kilometre.**—One thousand metres.
- Kilometric Capacity of Cable.**—The capacity of a cable in micro-farads per kilometre.
- Kilometric Insulation of Cable.**—The insulation of a cable measured in megohm-kilometres, or the average insulation of one kilometre in megohms.
- Kilo-Volt.**—One thousand volts.
- Kilo-Watt.**—One thousand watts.
- Kilo-Watt-Hour.**—(1) The amount of work equal to that performed by an activity of one kilowatt maintained steadily for one hour. (2) An amount of work equal to 3,600,000 joules.
- Kilo-Watt Hour Meter.**—A form of recording watt-meter.
- Kilo-Weber.**—One thousand webers.
- Kine.**—A unit of velocity, proposed by the British Association, equal to a centimetre-per-second.
- Kinematics.**—That branch of science which treats of motion, irrespective of the mass moved, or of the forces which produce or oppose the motion.
- Kinetic Energy.**—Energy producing motion, as distinguished from potential energy, or energy capable of producing motion.
- Kinetic Induction.**—Dynamic or mutual induction.
- Kinetic Theory of Matter.**—A theory which assumes that the molecules of matter are in a constant state of motion or vibration towards or from one another, in paths that lie within the spheres of their mutual attractions or repulsions.
- Kinetics.**—That branch of dynamics which treats of the action of forces in producing or modifying motion.
- Kinetoscope.**—A means for obtaining the effect of moving objects by means of a rapid succession of suitable pictures.
- Kinetograph.**—(1) A term at one time applied to a device proposed for the simultaneous reproduction of a distant stage and its actors under circumstances such that the actors can be heard at any distance from the theatre. (2) An apparatus for reproducing on a screen the image of a moving object.
- Kirchoff's Laws.**—The Laws for the pressures and currents in branched or divided circuits.
- Kneading Tools.**—Tools for shaping hot gutta-percha laid on a joint between gutta-percha covered wires.
- Knife-Break Switch.**—A knife switch.
- Knife-Edge Suspension.**—The suspension of a needle or system on knife-edges, supported on steel or agate plates.
- Knife-Edge Switch.**—A term sometimes used for knife-switch.
- Knife-Switch.**—(1) A switch which is opened or closed by the motion of a knife contact between parallel contact plates. (2) A knife-edge switch or knife switch.
- Knob Insulator.**—An insulator shaped like a knob and divided into two parts suitable for supporting a single wire when clamped together by its supporting screw.
- Knot.**—(1) A nautical mile, or 6087 feet. (2) A length equal to one minute of arc in terrestrial latitude. (3) A unit of velocity at sea equal to one naut per hour, ob-

tained from an observation of a knotted log-cord thrown overboard.

Knot-Pound.—A standard of conductivity of copper referred to a length of one knot and a conductor weight of one pound, and sometimes employed in submarine telegraphy.

Kohlrausch's Law.—In electrolytic conduction, the rate of motion of each atom in a given liquid is independent of the element with which it may have been combined.

Krizik's Bars or Cores.—Iron bars or

cores of various shapes, provided for solenoids, in which the distribution of the metal is so proportioned as to ensure a nearly uniform attraction or pull in different positions of the solenoid.

Kruss' Optical Scale.—A scale employed for measuring the height of a flame.

Kyanized.—Subjected to the kyanizing process.

Kyanizing.—A process employed for the preservation of wooden telegraph poles, or railroad ties or sleepers, by injecting a solution of corrosive sublimate into the pores of the wood.

L

L.—A symbol for coefficient of inductance.

L.—A contraction for length.

L.—A symbol for the coefficient of inductance or self-induction. (Partly international notation.)

L_m.—A symbol proposed for coefficient of mutual-induction, or mutual inductance.

L_s.—A symbol proposed for coefficient of self-induction, or self-inductance.

Labile Galvanization.—A term employed in electro-therapeutics, in contra-distinction to stabile galvanization, to designate the method of applying the current by keeping one electrode at rest, in firm contact with one part of the body, and connecting the other electrode to a sponge which is moved over the parts of the body that are to be treated.

Lag.—(1) Falling behind. (2) To fall behind.

Lag of Motor Brushes.—A movement of the brushes of a motor to a position on the commutator, in the opposite direction to its rotation, in order to obtain freedom from sparking.

Lag of Resultant Flux.—The displacement in phase of the magnetic flux in an induction motor behind the impressed magneto-motive force.

Lagging Electromotive Force.—An electromotive force or component of electromotive force lagging behind a current or flux.

Lagging Current.—A periodic current lagging behind the impressed electromotive force which produces it.

Lagging of Current.—An alternating current which is retarded in phase behind the pressure which produces it.

Lagging of Magnetization.—(1) A re-

tardation in the magnetization as compared with the magnetizing electromotive force. (2) A cyclic retardation of magnetization in a transformer due to hysteresis.

Lambert's Discharge Key.—A highly insulated form of double-contact key, used in testing.

Lamellar.—Composed of parallel plates or laminae.

Lamellar Distribution of Magnetism.

(1) The distribution of magnetism in magnetic shells. (2) Such a distribution of magnetism in a thin plate that the magnetized particles are arranged with their greatest lengths in the direction of the thickness of the plate, so that all the poles are situated at or near the faces of the plate, and, consequently, the extent of such polar surfaces is great when compared with the thickness of the plate.

Lamellar Magnet.—A magnet whose magnetism is characterized by lamellar distribution.

Laminated.—Built up or composed of laminae.

Laminated Core.—An iron core that has been sub-divided in planes parallel to its magnetic flux-paths, in order to avoid the injurious production of Foucault or eddy currents.

Laminated Magnet.—A magnet provided with a laminated core.

Laminating.—Sub-dividing into laminae.

Lamination.—The sub-division of an iron core into laminae.

Lamination of Armature Core.—The sub-division of the iron core of a dynamo or motor armature into a number of in-

ulated parallel strips or plates, for the purpose of avoiding eddy currents.

Lamination of Conductors.—(1) The division of a conductor into a number of parallel strands or wires, for the purpose either of lessening the eddy currents produced in its mass, or for reducing the skin effect when alternating currents are employed. (2) A stranded conductor.

Lamp Adapter.—(1) A device which permits an electric lamp to replace an ordinary gas burner on a gas bracket or chandelier. (2) A device which permits an electric lamp base of one manufacturer to be readily inserted in the socket of another manufacturer.

Lamp Base.—The portion of an incandescent lamp chamber through which the leading-in wires are passed, provided with two metallic plates or parts, suitably insulated from one another, and electrically connected to the ends of the leading-in wires.

Lamp Bracket, Electric.—A device similar to that employed for a gas burner, suitable for the support of an incandescent lamp.

Lamp Bulb.—The chamber or globe in which the filament of an incandescent lamp is placed.

Lamp Cap.—The base of an incandescent lamp.

Lamp Chamber.—The bulb of an incandescent lamp.

Lamp Circuit.—A circuit containing an electric lamp or lamps.

Lamp Clamp.—A suitable grip for holding the rod that supports the electrode of an arc-lamp.

Lamp Contacts.—Metallic plates or rings placed in an incandescent lamp base, and connected to the terminals of the filament.

Lamp Cord.—A flexible cord containing two separately insulated wires suitable for use in connection with an incandescent lamp.

Lamp Cut-Out.—(1) A device so arranged as to automatically cut a series-connected arc-lamp out of the circuit, as soon as the carbons are entirely consumed. (2) A safety catch or safety fuse connected with the circuit of a multiple-connected incandescent lamp.

Lamp Dimmer.—A reactive coil, employed on an alternating circuit for the purpose of varying the intensity of incandescent lights connected with such circuit.

Lamp Efficiency.—(1) Commonly, but

illogically, the watts consumed by a lamp per candle-power delivered. (2) More nearly correctly, the reciprocal of this; or the number of candles obtained from an incandescent lamp per watt supplied to it.

Lamp Feet.—(1) In a conducting loop, circuit, or system, the product of the number of lamps supplied and the distance at which they are supplied; each lamp being multiplied by its distance, and the sum of such products being taken. (2) A quantity sometimes used in computing distribution systems of electric lighting.

Lamp Filament.—The filament of an incandescent lamp.

Lamp Fittings.—(1) The sockets, holders, brackets, etc., required for holding, or supporting, incandescent electric lamps. (2) Lamp fixtures.

Lamp Frame.—The frame of an arc-lamp provided for the support of the feeding mechanism, globe, etc.

Lamp Hanger.—A device provided for the suspension of an arc-lamp.

Lamp Hood.—A hood employed to protect an arc-lamp from rain or snow, and generally so arranged as to throw its light in a downward direction.

Lamp-Hour.—(1) Such a service of electric current as is required to maintain one electric lamp during one hour. (2) Such a quantity of electricity, or of electric energy, as will maintain one standard lamp in normal operation for one hour.

Lamp Indicator.—(1) An apparatus employed in a central station to indicate the presence of the proper voltage, or potential difference, on the mains. (2) A lamp employed on a telephone switchboard to indicate when the subscriber is calling, or when he has rung off. (3) A pilot lamp. (4) Any indicating apparatus employing an electric lamp as signalling device.

Lamp Pendant.—A flexible cord employed for the support of a pendant lamp.

Lamp Pillar.—(1) A pillar supporting one or more lamps. (2) A lamp post.

Lamp Posts.—Posts provided for the support of lamps.

Lamp Protector.—A lamp hood, cover or guard.

Lamp Receptacle.—(1) A lamp socket or holder. (2) A receptacle for a flexible connection leading to a lamp.

Lamp Rod.—(1) The rod provided in an

ordinary arc-lamp for the support of the positive carbon. (2) In a focussing lamp, the rods provided for the support of the two carbons.

Lamp Socket.—A support provided for the reception of an incandescent lamp, so arranged that the introduction of the lamp therein, automatically connects the lamp terminals with the terminals of the supply wires.

Lamp-Socket Rheostat.—A regulable resistance placed in the socket of an incandescent lamp for the purpose of altering the quantity of light it emits.

Lamp-Socket Switch.—(1) A switch placed in the socket of an incandescent lamp, provided for lighting and extinguishing the lamp. (2) A lamp-socket key.

Lamp Switches.—Switches placed in the circuit of a group of incandescent lamps, either in the branches, or in the mains, for the purpose of simultaneously lighting or extinguishing a number of lamps.

Land Line.—(1) A telegraph line on land, either aerial or buried, as distinguished from a submarine cable. (2) An aerial telegraph line. (3) That portion of a submarine-cable circuit which extends over the land.

Lantern Lamp.—An incandescent lamp provided with a lantern-shaped chamber surrounding the lamp chamber.

Lantern Projector.—A focussing arc-lamp employed in connection with a projecting apparatus.

Lap Joint.—(1) The joint effected by overlapping short portions near the ends of the things to be joined, and securing them to each other while in that position. (2) A joint between the ends of two conducting wires in which the two ends after being laid together, side by side, are lapped firmly together by a piece of separate wire.

Lap-Joint for Wires.—A joint between two wires, made by overlapping their ends and subsequently soldering.

Lap Winding.—A winding for a drum armature, in which the successive conducting loops are arranged on the surface of the armature overlapping one another.

Large Calorie.—(1) A term sometimes used for the great calorie. (2) A kilogramme-degree-centigrade. (3) One thousand lesser calories.

Latent.—Hidden, concealed.

Latent Electricity.—A term formerly applied to bound electricity.

Lateral.—An offset from a conduit system

for connecting services with the conductors of a conduit.

Lateral Bracket.—A form of bracket for running wires from corner to corner of buildings, and for supporting an insulator in an upright position.

Lateral Discharge.—(1) A Leyden-jar or other impulsive discharge occurring between parts of the circuit not in the direct path of the main discharge. (2) A discharge occurring through an alternative path.

Lateral Induction.—(1) Induction occurring between closely-approached portions of a circuit, through which an impulsive discharge is passing. (2) The induction produced by an impulsive discharge as manifested in a lateral discharge.

Lateral Magnetic-Leakage.—(1) The failure of magnetic flux to pass in approximately parallel paths through a bar of iron or other magnetizable material, which has come to rest in a field in which it is free to move. (2) The escape of magnetic flux from the sides of a bar magnet, or other similar magnet, instead of from the poles at its ends.

Lattice Pole.—A form of structural-iron pole designed for the support of overhead wires or conductors, made in the form of a light, strong lattice.

Lattice Work of Pole.—A composite pole whose upper portion consists of structural lattice work, employed in cases where the stresses produced on the top of the pole are excessive by reason of the weight of the cables, or the number of lines or aerial wires supported thereon.

Launch, Electric.—A launch whose motive power is electric.

Law.—(1) In physics, any relation existing between natural phenomena and their causes. (2) The invariable manner in which physical causes produce their effects. (3) Any observed relation of sequences in the universe.

Law of Electro-Chemical Equivalence.—The amount of electrolytic liberation produced by an electric current passed through various chemical substances is proportional to the chemical equivalent of each substance, that is, to its atomic weight divided by its valency.

Law of Illumination.—The illumination produced by a single-point source of light, varies inversely as the square of the distance from that source.

Law of Ohm.—(1) The law of non-varying current strength in a circuit not subject to variation. (2) Ohm's law.

- Law of Volta.**—(1) The law of contact series. (2) Volta's law.
- Laws of Becquerel.**—Laws for the magneto-optic rotation of the plane of polarization.
- Laws of Coulomb.**—Laws for the force of attraction and repulsion existing between charged bodies, or between neighboring magnet poles.
- Laws of Faraday.**—Laws of electrolytic decomposition.
- Laws of Joule.**—Laws expressing the development of heat in a circuit by an electric current.
- Laws of Reflection.**—(1) The angle of incidence is equal to the angle of reflection. (2) Both the incident and the reflected rays lie in the same plane.
- Lay.**—The helical disposition of wires in a strand or sheath, in which each wire makes a complete revolution about the axis.
- Lay Torpedo.**—A moving torpedo, in which the motive power is either carbonic acid gas or compressed air, and the guiding power electricity.
- Layer.**—A name sometimes applied to an electro-plating deposit.
- Lay-Out of Cable in Tank.**—(1) The starting of a new flake in coiling a cable in a tank, by proceeding from the eye at the end of the finished flake, directly outward to the edge of the tank. (2) That part of a cable which connects the inside of one flake with the outside of the succeeding flake in a cable tank.
- Laying-Up Cables.**—Placing or disposing separate cables or conductors in a bunched cable.
- Lead.**—(1) An insulated conductor leading to or from an electric source. (2) In telegraphy, an insulated conductor leading to an instrument, battery, circuit, or station. (3) In a multiple or parallel-connected circuit, a conductor or main connected to the positive terminal of the source. (4) In a system of electric distribution, an insulated conductor leading to a main, feeder, source, station, testing apparatus, or device. (5) A connecting wire.
- Lead Accumulator.**—An accumulator or storage cell which has been formed from two plates of lead immersed in dilute sulphuric acid.
- Lead Burning.**—Effecting a metallic junction between two lead plates or strips by partially fusing them together.
- Lead-Covered Conductors.**—Insulated conductors sheathed in lead.
- Lead-Encased Cable.**—A cable provided with a sheathing or coating of lead on its external surface.
- Lead of Brushes of Dynamo-Electric Generator.**—An angular deviation from the normal position, forwards, or in the direction of rotation of the armature, which is given to the brushes on the commutator, in order to obtain sparkless commutation.
- Lead of Current.**—An advance in the phase of an alternating current beyond that of the electromotive force producing the current.
- Lead of Motor Brushes.**—The angular displacement from the normal position in the direction contrary to that of the rotation of the armature, which it is necessary to give the brushes on an electric motor, when its load is increased, in order to obtain freedom from sparking.
- Lead Scoring Tool.**—A tool for readily scoring the surface of a lead-covered cable, for the purpose of obtaining a clean surface preparatory to making a joint.
- Lead Sheathing.**—The coating of lead placed on the outside of a lead-covered cable.
- Lead Sleeve.**—A lead tube provided for making a joint in a lead-covered cable.
- Lead-Tin Alloys.**—Alloys of lead and tin, of low melting point, employed for safety fuses.
- Lead Tree.**—An arborescent deposit of lead obtained by the electrolysis of a solution of a lead salt.
- Lead Voltmeter.**—A voltmeter consisting of lead electrodes immersed in a dilute solution of sulphuric acid and water.
- Leaded Cable.**—A cable provided with a lead sheathing.
- Leading Current.**—An alternating-current wave or component, in advance of the electromotive force producing it.
- Leading Edge of Pole-Pieces of Armature.**—Those edges or terminals of the field-magnet pole-pieces which the armature is approaching in its rotation.
- Leading Horn of Pole-Pieces of Dynamo.**—Those edges or terminals of the field-magnet pole-pieces towards which the armature of a dynamo-electric machine is carried during its rotation.
- Leading-In Insulator.**—The insulator provided for the support of the wires leading into a building from an aerial circuit.
- Leading-In Tube.**—(1) A tube of insulating material provided for the reception

- of the leading-in wires in a building.
 (2) An insulating tube.
- Leading-In Wires.**—(1) The wires that pass from an aerial circuit into a house or building. (2) The wires or conductors which lead the current through an incandescent electric lamp; *i.e.*, into and out of a lamp. (3) Wires leading a circuit into a house, room, box, or apparatus.
- Leading Pole of Dynamo or Motor.**—The pole of a dynamo or motor approached by points on the surface of the revolving armature which lie between the poles at any instant.
- Leading-Up Wires.**—Wires employed for raising an aerial cable to the cable hangers.
- Leads.**—(1) In a system of parallel distribution, the conductors connected to the positive and negative terminals of a source. (2) Generally, the conductors in any system of electric distribution. (3) Conductors which lead the current to or from any source, circuit or device. (4) In electric testing the insulating conductors leading the testing current to the circuit or conductor tested.
- Leak.**—(1) Any loss or escape by leaking. (2) The point or place where a leak occurs.
- Leakage.**—A loss or escape by leaking.
- Leakage Conductance.**—Insulation conductance, or the reciprocal of the insulation resistance.
- Leakage Conductor.**—(1) A conductor placed on a telegraphic circuit for the purpose of preventing the disturbing effects of leakage into a neighboring line by providing a direct path for such leakage to the earth. (2) A conductor placed on a telegraphic line for the purpose of lessening the retardation of the line by assisting in its discharge.
- Leakage Current of Primary.**—(1) The magnetizing current which flows into the primary circuit of a transformer when the secondary circuit is open. (2) A current employed in magnetizing only, as distinguished from a current usefully transformed.
- Leakage Current of Transformer.**—(1) The current which flows into the primary circuit of a transformer when the secondary circuit is opened. (2) The magnetizing current.
- Leakage Drop.**—The drop produced in a circuit by leakage.
- Leakage, Electric.**—The gradual dissipation of a charge or current due to insufficient insulation.
- Leakage Factor.**—In a dynamo-electric machine, the ratio of the total flux, which passes through the field-magnet cores of a dynamo or motor, to the total useful flux passing from them through the armature.
- Leakage Flux.**—(1) That portion of the field flux which does not pass through the armature of a dynamo or motor, and which, therefore, produces no useful effect. (2) The stray flux, or that from which no useful effect is obtained.
- Leakage Indicator.**—(1) A magnetic explorer. (2) An electric testing apparatus for revealing the presence of leakage in any circuit or system.
- Leakage Interference.**—Interference between two or more circuits due to their mutual leakage.
- Leakage Magnetic Resistance.**—The reluctance to leakage magnetic flux.
- Leakage Method of Measuring Insulation.**—A method of measuring the insulation of a conductor or condenser by determining the rate at which it loses charge by leakage.
- Leakage Paths.**—The paths traversed by leakage magnetic flux.
- Leakance.**—A term proposed for leakage-conductance in a circuit.
- Leclanché's Voltaic Cell.**—A zinc-carbon couple whose elements are used in connection with a solution of sal-ammoniac, and a quantity of finely divided black oxide of manganese surrounding the carbon.
- Lecture Galvanometer.**—A form of galvanometer suitable for showing the movements of a galvanometer needle to an audience at a considerable distance from the instrument.
- Left-Hand Trolley-Frog.**—A trolley-frog so arranged as to switch a car to the left.
- Left-Hand Trolley-Switch.**—A switch arranged to divert a car to the left of a main line.
- Left-Handed Armature-Windings.**—Armature windings applied to the core in a left-handed or sinistrorsal helix.
- Left-Handed Dynamo.**—A dynamo which runs left-handedly, or counter-clockwise, when regarded from the pulley end.
- Left-Handed Helix.**—(1) A left-handed solenoid. (2) A helix wound left-handedly, or counter-clockwise.
- Left-Handed Motor.**—A motor which runs left-handedly, or counter-clockwise, when regarded from the pulley end.

- Left-Handed Rotation.**—A rotation in a positive or counter-clockwise direction.
- Left-Handed Solenoid.**—A solenoid whose winding is left-handed, or counter-clockwise.
- Left-Handed Spiral.**—A left-handed helix.
- Left-Handed Winding.**—The winding of a solenoid or helix in a counter-clockwise direction.
- Leg.**—In a system of telephonic exchange, where a ground-return is used, a single wire; or, where a metallic circuit is employed, two wires, provided for connecting the subscriber with the main switch-board, so that any subscriber may be placed directly in circuit with two or more other subscribers.
- Leg Key.**—A Morse telegraphic key having long screw in its base for passing through a table.
- Leg of Circuit.**—(1) A branch of a bifurcated or divided circuit. (2) A loop or offset in a series circuit.
- Leg of Electro-Magnet.**—One of the cores of an electro-magnet.
- Legal Earth Quadrant.**—(1) A practical unit of inductance as defined by the Electrical Congress of 1884, at Paris, and as distinguished from the true earth quadrant. (2) The legal quadrant.
- Legal Ohm.**—(1) An ohm whose value is in accordance with the definition of the Electrical Congress of 1884, in Paris. (2) The resistance of a uniform column of mercury one square millimetre in area of cross-section, and 106 centimetres in length, at the temperature of 0° Cent., or 32° Fahr. (3) The concrete standard ohm as defined by the Electrical Congress of 1884, at Paris, as distinguished either from the B. A. ohm, the true ohm, or the International ohm.
- Legal Quadrant.**—(1) The legal earth quadrant. (2) The unit of self-induction based upon the definitions of the Electrical Congress of 1884, in Paris.
- Legged.**—Placed in a circuit by means of a leg.
- Legging Key-Board.**—A key-board employed for the purpose of legging an operator into a circuit containing two or more subscribers.
- Legless Key.**—(1) A name sometimes given to a Morse telegraphic key provided with a flat base. (2) A self-closing key.
- Length of Spark.**—The air distance traversed by a disruptive discharge.
- Lenard Effect.**—The effect produced by the Lenard Rays, in causing fluorescence, and in passing through some substances that are opaque to light.
- Lenard Rays.**—The peculiar radiation emitted from that external portion of a Lenard tube that is directly opposite the cathode.
- Lenard Tube.**—A form of high-vacuum tube provided with an aluminium plate, hermetically sealed in that portion of the wall of the tube lying directly opposite the cathode, and employed for producing Lenard rays.
- Lens.**—A medium, transparent to radiant energy, provided with a curved face or faces, and employed to bring a beam or pencil of light to a single point or focus.
- Lens Lamp.**—An incandescent lamp provided with a small lens hermetically fixed in a portion of its wall, opposite a suitably placed reflector.
- Lens-Mirror Projector.**—A form of projector whose operation is dependent on the combined action of a mirror and a lens.
- Lenz's Laws.**—Laws for determining the direction of currents produced by electro-dynamic induction.
- Lesser Calorie.**—(1) The small calorie. (2) The therm. (3) The water-gramme-degree-centigrade.
- Letter-Box, Electric.**—A device that announces the deposit of a letter in a box by the ringing of a bell, or by the moving of a needle or index.
- Letter Printing Instrument.**—A type-printing telegraphic instrument.
- Level, Electric.**—An equipotential electric surface.
- Level of Earth, Electric.**—A term sometimes employed for the potential of the earth.
- Lever Brake for Car.**—A form of car brake operated by means of a brake handle.
- Lever Hook.**—(1) The hook in an automatic telephone switch on which a telephone receiver is hung when not in use. (2) A contact lever provided with a hook for supporting a telephone.
- Lever Switch.**—(1) A switch mounted upon a fulcrum axis like a lever. (2) A switch operated by the movements of a lever. (3) A telephone switch of a multiple telephone switch-board, operated by a lever.
- Leyden-Jar.**—A condenser in the form of a jar, in which the metallic coatings are placed opposite each other respectively on the outside and inside of the jar.

Leyden-Jar Battery.—The combination of a number of separate Leyden jars so as to act as a single jar.

Leyden-Jar Discharge.—(1) The disruptive discharge produced by a Leyden jar. (2) A name sometimes given to an oscillatory discharge.

Leydic Resistance.—A term proposed for the resistance offered by various metallic circuits to condenser discharges.

Lichtenberg's Dust-Figures.—Figures obtained by writing on a sheet of shellac with the knob of a charged Leyden jar, and then sprinkling over the sheet, dried, powdered sulphur and red lead, which have been previously mixed together and are thereby rendered respectively negative and positive.

Lichtenberg's Electric Figures.—A term sometimes applied to Lichtenberg's dust-figures.

Life Curve of Incandescent Electric Lamp.—A curve in which the life of an incandescent electric lamp is represented by means of abscissæ and ordinates that are respectively equal to the life in hours and the candle-power at constant pressure, or the pressure at constant candle-power.

Life of Electric Incandescent Lamp.—The number of hours that an incandescent electric lamp will continue to furnish a good commercial light when operated at normal pressure.

Lift, Electric.—An electrically operated lift or elevator.

Light.—(1) That particular form of radiant energy by means of which objects are rendered visible. (2) The flow or flux of light emitted from a luminous source.

Light Bath, Electric.—A form of electrotherapeutic bath in which the patient is exposed to the radiation of a number of incandescent lamps.

Light Cell.—A term sometimes employed for a photo-electric cell.

Light, Electric.—Light produced by the action of electric energy.

Light Escape.—A partial ground or earth.

Light-House Illumination, Electric.—The application of the electric arc-light to light-houses.

Light Indicator of Railroad Signal.—A device by means of which an indication is given electrically, at a distance, as to whether a signal lamp is lighted or not.

Light Load of Machine.—A partial load, or a load which is small by comparison with the capacity of the machine.

Light Cable, Electric.—A cable employed for furnishing the current required for the maintenance of electric lights.

Lighting Circuits.—Any electric circuit for the distribution of light.

Lightning.—A spark or discharge that results from the disruptive discharge of a cloud to the ground, or to a neighboring cloud.

Lightning Arrester.—A device by means of which the apparatus placed in any electric circuit is protected from the destructive effects of a flash or discharge of lightning.

Lightning - Arrester Board.—The board to which the lightning arresters of a system of telephonic or telegraphic communication are connected.

Lightning-Arrester Earth.—The earth provided for the grounding of the earth-plate of a lightning arrester.

Lightning Bolt.—A lightning flash or discharge.

Lightning Conductor.—A lightning rod.

Lightning Deviator.—A term sometimes used for lightning arrester.

Lightning Discharger.—A term sometimes used for lightning protector.

Lightning Flash.—A lightning discharge.

Lightning Guard.—A term sometimes used for lightning rod.

Lightning Jar.—A Leyden-jar whose coatings consist of metallic filings in the gaps between which an irregular series of sparks, somewhat resembling a lightning flash, appear on the discharge of the jar.

Lightning Rod.—A rod, strap, wire, or stranded cable, of good conducting material, placed on the outside of a house or other structure, in order to protect it from the effects of a lightning discharge.

Lightning Rods for Ships.—A system of rods or conductors designed to afford electric protection for vessels at sea.

Lightning Stroke.—(1) A disruptive discharge occurring between two oppositely charged clouds, or between a cloud and the earth. (2) A lightning flash.

Lightning Tube.—A fulgurite.

Lime Light.—A source of light obtained by the incandescence of a cylinder of lime under the influence of the oxy-hydrogen blow-pipe.

Limit Switch.—A small automatic switch on an electric street car, connected in series with the brake discs, and so arranged as to be capable of cutting out the fields of

- both motors when the braking current is excessive.
- Limiting Distance of Speech.**—(1) The length of circuit, or the distance to which a circuit may be carried in a straight line, at which telephonic conversation is just practicable. (2) The limiting length of line to which telephonic speech can be carried successfully, depending upon the electric conditions of the circuit, and the nature of the apparatus employed.
- Limiting Speed of Cable.**—The speed to which the transmission of signals through a cable is limited, by reason of its electrostatic capacity and resistance.
- Limiting Stop.**—A stop set so as to limit the motion of an electrically vibrating or oscillating bar to any pre-determined extent.
- Limiting Temperature-Elevation.**—A temperature elevation of any apparatus which is not to be exceeded during its prolonged operation.
- Line.**—Generally, a wire or conductor connecting any distant points or stations.
- Line Adjuster.**—An instrument employed for overcoming the effects of leakage on the adjustment of the relays in a telegraphic circuit.
- Line Arrester.**—The lightning arrester connected to a line or circuit.
- Line Circuit.**—(1) The wires or other conductors in the main line of a telegraphic or other circuit. (2) A transmission circuit for electric energy.
- Line Crosses.**—Electric crosses occurring on lines.
- Line Crossing.**—(1) The place where two overhead trolley conductors cross each other. (2) A metallic plate uniting the ends of trolley wires, where one wire crosses another.
- Line Cross-Over.**—(1) A trolley crossing. (2) A trolley cross-over.
- Line Drop.**—In a telephone switchboard, an electro-magnetic drop connected to a line.
- Line Dynamometer.**—A dynamometer employed during the erection of an overhead line, in order to determine whether it has been pulled up to its proper tension.
- Line Insulator.**—An insulator employed for the support of an aerial line.
- Line Integral.**—A continuous summing up of some instantaneous quantity executed or conducted along a continuous line.
- Line Jacks.**—In a telephone switchboard, a jack connected to a line.
- Line of Least Sparking.**—The diameter of sparkless commutation.
- Line Peg.**—A peg or plug in a switchboard connecting the line with translating devices or with another line.
- Line-Pressure Compensator.**—A device for attachment to a voltmeter in an alternating-current system, whereby the voltmeter indications are compensated for the drop of pressure in the feeder, and are such as would be obtained if the instrument were directly connected to the mains.
- Line Reactance.**—The reactance of a line conductor.
- Line Section of Electric Railroad.**—Any part of a trolley, or other railroad line, so insulated from other parts as to permit of the separate control of its supply of electric power.
- Line Selector.**—A wire selector.
- Line Wire.**—In telegraphy, the wire that connects the different stations with one another.
- Line-Wire Tier.**—A tie wire of soft copper or soft iron employed for holding the line wire to the insulator.
- Lines of Electric-Displacement.**—Lines of electric flux, along which electric displacement takes place.
- Lines of Electric-Induction.**—The lines along which electric induction takes place.
- Lines of Electrostatic-Flux.**—The lines along which electrostatic flux passes.
- Lines of Electrostatic-Force.**—(1) Lines of force produced in the neighborhood of a charged body by the presence of the charge. (2) Lines extending in the direction in which the force of electrostatic attraction or repulsion acts.
- Lines of Inductive-Action.**—Lines of electrostatic force.
- Lines of Magnetic-Force.**—(1) Lines in which magnetic force acts. (2) Lines extending in the direction in which the force of magnetic attraction or repulsion acts.
- Lines of Magnetic-Induction.**—(1) Magnetic flux-paths. (2) The lines in which magnetic induction proceeds.
- Lines of Magnetization.**—(1) A term sometimes applied for lines of magnetic induction. (2) A term sometimes applied to those portions of the lines of magnetic force which lie within the magnetized substance.
- Lineants.**—A term proposed as a unit of magnetic flux in place of webers, and

- equal to the pressants divided by the resistants, or to the magneto-motive force divided by the reluctance. (Not used.)
- Linear Capacity.**—The quotient of the capacity of a line or conductor by its length.
- Linear Capacity of Cable.**—The electrostatic capacity of a cable per-unit-of-length.
- Linear Coefficient of Expansion.**—The increase in a unit length of a substance when subjected to unit difference of temperature.
- Linear Density, Electric.**—The amount of electrification per unit of length.
- Linear Density of Charge.**—The density of charge per-unit-of-length.
- Linear Insulation.**—The product of the total insulation of a line by its length.
- Linear Insulation of Cable.**—The product of the insulation resistance of a cable by its length.
- Linear Spectrum.**—A spectrum consisting of a few isolated frequencies.
- Line-Man.**—One who puts up and repairs line circuits, and attends to the receptive devices connected therewith.
- Link-Fuse.**—A link-shaped leaden plate, provided with suitable ends for connection with the copper fuse-wire terminals.
- Link-Fuse Cut-Out.**—A cut-out employing a link-fuse.
- Linkages.**—In a coil traversed by a current, the sum of the magnetic flux due to that current linked with the coil, obtained by considering the quantity of flux linked with each turn, separately and successively, and adding the fluxes so obtained.
- Linked Magnetic and Electric Circuits.**—A phrase sometimes employed to represent the interlinked condition of magnetic and electric circuits.
- Liquid Compass.**—A form of ship's compass in which the compass-needle is suspended, not only by the usual gimbals, but is also so arranged that its oscillations are checked by a surrounding liquid.
- Liquid Flow.**—The quantity of liquid that escapes from an orifice, or passes through any cross-section of a pipe or channel, in a given time.
- Liquid-Level Alarm, Electric.**—A device for electrically sending an alarm when a liquid level differs materially from a given level.
- Liquid Resistance Load.**—An artificial load for a dynamo consisting of a mass of liquid interposed between suitable electrodes.
- Liquid Thermostat.**—A thermostat whose operation depends on the expansion of a liquid.
- Liquefaction.**—The conversion of a solid into a liquid by the addition of heat, or of a gas into a liquid, either by the removal of heat, or by the combined influence of low temperature and pressure.
- Listening Cam.**—In a telephone system a metallic cam or lever-key by means of which an operator readily places her telephone in circuit with a subscriber.
- Listening Key.**—In a telephone switchboard, a listening cam.
- Lithanode.**—Highly conducting lead peroxide in a solid form suitably prepared for the plate of a storage cell.
- Line Trolley-Crossing.**—(1) The point or plate where two trolley wires cross each other at a street crossing. (2) A line crossing.
- Live Wire.**—(1) A wire through which current is passing. (2) A wire connected with an electric pressure or source.
- Liverpool Repeater.**—A name given to a form of telephone repeating induction coil in which the iron core is constructed of thin wires bent around over the coils, so as to overlap at the ends, and form a complete magnetic circuit.
- Load.**—The work thrown on any machine.
- Load-Diagram of Station.**—A curve which represents the output of a station for a given time, say for the twenty-four hours of the day.
- Load-Factor.**—The ratio of the average to the maximum load.
- Load of Dynamo.**—The current delivered by a dynamo.
- Load-Panel.**—The panel of a central-station switchboard provided with apparatus for indicating the total station-load.
- Loadstone.**—An objectionable orthography sometimes employed for lodestone.
- Local Action of Dynamo-Electric Machine.**—The loss of energy in a dynamo by the establishment of eddy currents in its pole-pieces, cores, or other conducting masses.
- Local Action of Voltaic Cell.**—An irregular consumption of the zinc, or positive element of a voltaic cell, by the fluid or electrolyte when the circuit is opened or broken, as well as when it is closed or in regular action.
- Local Battery.**—A voltaic battery thrown into or out of action by a relay and employed at a station on a telegraphic line,

to operate a sounder, or a registering or recording apparatus, at that point only.

Local Battery Circuit.—The circuit in a telegraphic system in which is placed the local battery, as distinguished from the main battery.

Local Calls.—At a central telephone exchange, a call received from a subscriber connected directly therewith, as distinguished from a call received from another exchange.

Local Currents.—A term sometimes used for eddy currents.

Local Faradization.—A method of therapeutically applying the voltaic current, similar in general to that employed in local galvanization.

Local Galvanization.—The application of galvanization to portions of the body only, in contradistinction to general galvanization.

Local Jack.—In a multiple telephone switchboard, an answering jack corresponding to a local line drop, or a jack separated from the main body of the switchboard and set in a local row for the convenience of the operator in answering calls.

Localization of Faults.—Determining the position of a fault on a telegraphic line or cable by electrical tests applied at one or both ends.

Localization Test.—A test of a faulty circuit made to determine the position of the fault.

Localized Capacity.—Capacity inserted in a circuit in one or more condensers, as distinguished from distributed capacity, or that which is present throughout the entire circuit.

Localized Inductance.—Inductance inserted in a circuit at one or more points, as distinguished from distributed inductance which is present throughout the entire circuit.

Localized Vector.—(1) A vector function of space. (2) A vector point-function. (3) A vector quantity which is a property of every point of a region.

Locally Inter-Connected Switchboard. A switchboard sub-divided into sections, each provided with auxiliary jacks which are interconnected among the different sections.

Lock, Electric.—A lock that is automatically released by the aid of a distant push-button.

Locomotive, Electric.—(1) A locomotor whose motive power is electricity. (2) An electrically-driven locomotive engine.

Locomotive Head-Light, Electric.—An electric light placed in the focus of a parabolic reflector in front of a locomotive engine.

Locomotor.—A travelling motor, as distinguished from a stationary motor.

Locomotor, Electric.—An electrically driven locomotor.

Lodestone.—A name given to a piece of naturally magnetized iron ore.

Lodge's Standard Voltaic Cell.—A standard form of Daniell's cell.

Log, Electric.—An electric device for measuring the speed of, or the distance traversed by, a vessel.

Logarithm.—The exponent, or the power to which it is necessary to raise a fixed number called the base, in order to produce a given number.

Logarithmic.—Of or pertaining to a logarithm.

Logarithmic Curve.—A curve in which the rate of increase or decrease of the ordinate is proportional to the ordinate itself.

Logarithmic Decrement of Galvanometer.—(1) In a series of galvanometer swings or deflections, the ratio of any pair of successive amplitudes. (2) The ratio of any two successive total swings or deflections of a galvanometer needle.

Logging Motor, Electric.—(1) An electric locomotor employed for hauling logs. (2) A form of telfer motor moving over a cable way, usually over a swamp, for hauling logs out of the same.

Long-Arc System of Electric Lighting. A system of arc lighting employing long arcs and, consequently, high electro-motive forces.

Long-Closed Circuit.—A series circuit in which all the devices are included as distinguished from a series circuit in which some of the electro-receptive devices are cut-out.

Long-Coil Magnet.—(1) An electro-magnet whose magnetizing coil consists of many turns of fine wire. (2) A high-resistance magnet.

Long-Connection Armature-Winding. Such a connection of a two-circuit armature winding that in each circuit electro-motive forces are produced by field poles of one polarity only.

Long Connection of Two-Circuit Gramme-Windings.—A form of Gramme winding in which the two circuits from brush to brush consist of conductors that are influenced by only one-half the poles.

- Long-Core Electro-Magnet.**—An electro-magnet with a long core.
- Long-Distance Carbon Telephone Transmitter.**—A form of microphonic telephone transmitter suitable for use on long-distance circuits.
- Long-Distance Telephone Cabinet.**—An approximately sound-tight cabinet employed for convenience and secrecy in telephonic communication.
- Long-Distance Transmission.**—Transmission of electric energy over fairly considerable distances.
- Long End of Quadruplex Battery.**—The end of a quadruplex battery that is further from the point of intermediate connection than the short end.
- Long-Range Electrometer.**—An electrometer the range of whose scale is comparatively long.
- Long-Shunt Compound-Winding.**—A compound winding of a dynamo-electric machine in which the shunt coil is connected directly, or through resistance, with the terminals of the machine, as distinguished from a short-shunt compound-winding.
- Long-Shunt Compound-Wound Dynamo-Electric Machine.**—A compound-wound dynamo, in which the shunt-field magnet coils form a shunt to the binding posts of the machine.
- Longitudinal Magnetization.**—Such a magnetization of a bar or rod, that its separate magnetic particles are arranged with their axes lying in the direction of the length of the bar.
- Longitudinal Vibrations.**—Vibrations set up in an elastic medium in the direction of propagation or transmission, as distinguished from transverse vibrations which occur at right angles to the direction of propagation.
- Loom, Electric.**—An electrically operated loom, in which the Jacquard cards of the ordinary loom are replaced by simple perforated metal plates, whose perforations correspond to those in the Jacquard cards.
- Loop Bracket.**—(1) A insulating bracket from which a conducting loop can conveniently be run so as to include a source or translating device. (2) A bracket for holding two insulators and wires, such as might form a loop.
- Loop-Break.**—A device for introducing a loop in a break made at any part of a circuit.
- Loop-Circuit.**—(1) A term sometimes applied to a circuit in parallel or multiple-arc. (2) A metallic circuit. (3) A circuit having two wires, one out-going and the other returning, as distinguished from an earth-return circuit.
- Loop Cut-Out.**—A cut-out placed in a loop.
- Loop, Electric.**—A portion of a main circuit consisting of a wire going out from one side of a break in the main circuit and returning to the other side of the break.
- Loop-Mile.**—(1) A mile of going and return conductor in a loop circuit. (2) A mile of double conductor. (3) A double mile of conductor. (4) A distance of one mile traversed by a pair of conductors.
- Loop or Spreader Bracket.**—A bracket used on cross-arms for taking off loops that are to be carried to service wires, branch mains, or transformers.
- Loop Switch.**—A switch for opening or closing a loop, or for throwing a loop into or out of a main circuit. (2) A switch for connecting a branch office with a duplex or quadruplex switch at a main office, so that the branch office assumes control of one set of apparatus; *i. e.*, sends and receives messages on the duplex or quadruplex system.
- Loop System of Distribution.**—A system of distribution employed in the early history of electric lighting, in which each of a number of lamps was furnished with current through a single machine by means of a separate and independent loop or circuit connected with the terminals of such machine.
- Loop-System of Parallel Distribution.**—A system of parallel distribution in which a pair of mains is connected to a generator in a manner designed to equalize the drop of pressure; one main being connected at the home end directly to the generator, and the other being connected at its distant end to the generator through a separate wire.
- Loop Test.**—A localization test for a fault in a loop of two telegraphic wires, or in a complete metallic circuit.
- Loop Winding.**—A term sometimes used for lap-winding.
- Loop-Winding of Alternator.**—(1) Coil winding. (2) An alternator armature-winding in which the wire is laid on the surface of the armature core in loops or coils.
- Loops of Force.**—A term sometimes applied for lines of force.
- Loops of Induction.**—A term sometimes applied for lines of magnetic induction.
- Loops of Mutual-Induction.**—Loops or lines of induction produced in any cir-

- cuit by variations in the intensity of the current flowing in a neighboring circuit.
- Looping-In.**—A term sometimes employed for a method adopted in grounded telephone or telegraph circuits for connecting several instruments in series in a loop in that circuit, so that any conversation must be transmitted through all the instruments which happen to be in the circuit between the parties connected.
- Loss Plate of Voltmeter.**—(1) That plate of a voltmeter from which the metal is electrolytically dissolved during the passage of the current. (2) The plate connected with the anode or positive terminal.
- Loose Carbon Transmitter.**—(1) A telephone transmitter employing loose carbon or carbon dust. (2) A dust telephone transmitter.
- Loose Contact.**—A contact effected by two or more surfaces that rest loosely on one another, or by means of their weight only.
- Loose-Handle Switch.**—A form of switch in which the handle after it has been moved a short distance falls into a new position of equilibrium.
- Loss of Continuity.**—A disconnection or interruption of a circuit.
- Loud-Speaking Telephone.**—(1) A name given to any telephone characterized by the intensity of the sounds produced by its receiver. (2) A name sometimes given to the electro-motographic telephone.
- Loudness.**—That quality of a sound which depends on the amplitude of its vibrations.
- Low-Frequency.**—(1) A frequency of but comparatively few alternations per second. (2) Any frequency lower than that usually employed.
- Low-Frequency Transformer.**—A transformer designed for operation on a low-frequency circuit.
- Low-Potential Current.**—A term sometimes used for a current on a low-pressure circuit.
- Low-Potential System.**—In the National Electric Code, a system having a pressure less than 300 volts.
- Low Pressure.**—A comparatively small pressure or electromotive force.
- Low-Pressure Circuit.**—A circuit designed for use in connection with low electric pressure.
- Low-Pressure Incandescent Lamp.**—An incandescent lamp whose filament is short and thick, and, consequently, of low electric resistance suited for a low pressure.
- Low-Resistance Magnet.**—A magnet wound with low-resistance magnetizing coils.
- Low-Speed Electric Motor.**—An electric motor designed to run normally at low speeds.
- Low Tension.**—A term sometimes used for low pressure.
- Low-Tension Bus.**—In a central station any bus-bar connected with a low-tension generator.
- Low-Tension Electric Fuse.**—A fuse that is ignited by heating a wire to incandescence by the passage of an electric current of low pressure, as distinguished from a high-tension fuse.
- Low-Tension Switch.**—A switch designed for use on low-tension circuits.
- Low Vacuum.**—(1) A vacuum in which the mean-free-path of the molecules of the residual gas is small as compared with the dimensions of the containing vessel. (2) A space from which only a portion of the air or residual gas has been removed.
- Loxodograph.**—An apparatus for electrically recording on paper the actual course of a ship, by the combined action of magnetism and photography.
- Lubricating.**—Reducing friction by means of lubrication.
- Lubrication.**—The reduction of friction between surfaces, by rendering them slippery.
- Luces.**—A plural of lux.
- Lumen.**—(1) A unit of flux-of-light equal to the light received by a square metre of spherical surface, from a point source of unit intensity, placed at the centre of a sphere one metre in radius. (2) The flux of light through a steradian from a point source, whose intensity is one pyr. (3) A pyr-steradian.
- Lumen-Meter.**—An instrument for measuring the flux of light.
- Lumen-Second.**—A rad.
- Lumination.**—A term proposed for illumination. (Not in use.)
- Luminescence.**—A limited power for emitting light possessed by certain bodies which have previously acquired potential energy by exposure to light or radiant energy.
- Luminescence Lamp.**—(1) A fluorescent lamp. (2) A lamp rendered luminescent by bombardment. (3) An X-ray lamp. (4) A vacuum-tube lamp.

Luminiferous.— Bearing or carrying light.

Luminosity.—A term sometimes used for the brightness of a source.

Luminous Absorption.—The absorption of luminous energy in its passage through bodies.

Luminous Efficiency.—The ratio which the luminous radiation emitted by a source bears to the total radiant energy emitted by such source in a given time.

Luminous Flux.—A phrase sometimes employed for flow of light.

Luminous Frequencies.—Physiologically effective frequencies, or those capable of producing the sensation of light.

Luminous Heat.—Heat radiation accompanied by or containing physiologically effective frequencies.

Luminous Intensity.—The amount of visible radiation emitted from a luminous source per-unit-of-area of surface.

Luminous Interference.—Interference produced by light waves of the same frequency when out of phase with each other.

Luminous Radiation.—Radiation capable of affecting the eye.

Lummer-Brodhun Screen.—A form of photometric screen requiring the use of

but one eye, thus eliminating any errors due to the varying sensibility of the two eyes, each of the two sources of light that are being compared illumining its own field only, and these two fields being presented to the eye as a disc and circle respectively, the latter surrounding the former, and yet having a sharp line of separation from it.

Lunar-Inequality of Earth's Magnetic Variation.—Small changes in the value of the magnetic variation or inclination, dependent on the position of the moon as regards the magnetic meridian.

Lunar-Inequality of Earth's Magnetism.—Small variations in the value of the earth's magnetic elements dependent on the position of the moon as regards the magnetic meridian.

Lux.—(1) A unit of illumination equal to the light received on each square metre of the interior of a sphere whose radius is one metre, from a bougie-decimale placed at its centre. (2) An illumination equal to a lumen-per-square-metre. (3) The normal illumination produced by one carcel at a distance of a metre.

Lux-Second.—(1) The time-illumination of one lux during one second. (2) A unit of time-illumination employed in photography. (3) A phot.

M

M.—A contraction sometimes employed to express a pressure of the millionth of an atmosphere.

m.—A symbol for magnetic moment.

m.—A symbol for strength of magnetic pole.

m.—An abbreviation for metre, a practical unit of length.

m.—An abbreviation for minute, a practical unit of time.

μ .—A symbol for magnetic permeability or inductivity. (International notation.)

μ .—A symbol for micron, the millionth of a metre, or one thousandth of a millimetre.

$\mu\mu$.—A symbol for bicron, the millionth of a millimetre, or thousandth of a micron.

m².—An abbreviation for square metre, a practical unit of surface.

m³.—An abbreviation for cubic metre, a practical unit of volume.

m.a.—A contraction for milli-ampere.

m : s.—An abbreviation proposed for metre-per-second, a practical unit of velocity.

m : s².—An abbreviation proposed for metre-per-second-per-second, a unit of acceleration.

mm.—A contraction for millimetre.

M. Current.—A term proposed for mean current.

M. M. F.—A contraction for magnetomotive force.

M. P.—A contraction for man-power.

M. P. H.—A contraction sometimes employed in railroad work for miles-per-hour.

M. S. Current.—A term proposed for mean-square-current.

Mac or Mack.—A term at one time proposed for the practical unit of self-inductance, after Maxwell.

Machine Seal of Lamp Chamber.—A hermetical seal effected mechanically be-

- tween the glass support of an incandescent lamp and the walls of the lamp chamber.
- Machine Telegraphic Transmission.**—High-speed telegraphic transmission effected by means of an automatic telegraphic transmitter.
- Machine Telegraphy.**—Automatic or high-speed telegraphy.
- Machine Tool, Electric.**—An electrically driven machine tool.
- Made Circuit.**—A completed circuit.
- Magazine Fuse.**—A safety fuse containing a number of spare fuses, so arranged as to readily permit the replacement of the fuse when blown, either automatically, or by hand.
- Magic Pane.**—A condenser formed of a sheet of glass, covered on one side with pieces of tin-foil, with small spaces left between them disposed in some design on the glass, which design becomes luminous on the discharge of the condenser.
- Magne-Crystalline Action.**—A term proposed by Faraday to express differences in the action of magnetism on crystalline bodies in different directions.
- Magne-Crystalline Force.**—The force which produces magne-crystalline actions.
- Magne-Electric Induction.**—A variety of electro-dynamic induction in which electric currents are produced by the motion of permanent magnets past conductors, or of conductors past permanent magnets.
- Magnes Stone.**—An old name for magnetite or for a natural magnet.
- Magnet.**—(1) Any body producing magnetic flux. (2) A body possessing the power of attracting the unlike pole of another magnet, or of repelling the like pole, or of inducing magnetism in magnetizable bodies.
- Magnet Coil.**—A coil of insulated wire surrounding the core of an electro-magnet, through which the magnetizing current is passed.
- Magnet Cores.**—Bars or cylinders of iron on which the magnetizing coils of wire are placed.
- Magnet Operation.**—The use of a magnet for the purpose of removing particles of iron from the eye.
- Magnetic or Magnetical.**—Of or pertaining to a magnet.
- Magnetic A-B-C-Instrument.**—A step-by-step dial telegraph instrument employing magneto-induced currents.
- Magnetic Adherence.**—Adhesion between surfaces, due to their mutual magnetic attractions.
- Magnetic Aelotropy.**—A difference in the magnetic susceptibility of a mass of iron in different directions.
- Magnetic Air-Circuit.**—That portion of a magnetic circuit which passes wholly through air.
- Magnetic Air-Gap.**—Any gap in an aeroferric magnetic circuit filled with air.
- Magnetic Alternator.**—A magneto-alternator.
- Magnetic Atmosphere.**—(1) A term formerly employed for a space filled with the assumed magnetic effluvia. (2) A magnetic field.
- Magnetic Attraction.**—The mutual attraction exerted between unlike magnetic poles.
- Magnetic Axis.**—(1) The line along which a magnetic needle, free to move, but which has come to rest in a magnetic field, can be turned without changing the direction in which it comes to rest. (2) The line connecting the poles of a bar magnet or needle.
- Magnetic Axis of Straight Needle.**—A straight line drawn through a magnetic needle joining its poles.
- Magnetic Azimuth.**—(1) The arc intercepted on the horizon, between a magnetic meridian and a great circle passing through the observed body. (2) A magnetic bearing.
- Magnetic Battery.**—The combination of a number of separate magnets so as to be capable of acting as a single magnet.
- Magnetic Bearing.**—The horizontal angle included between a horizontal line from an observer's eye to an object and the observer's magnetic meridian.
- Magnetic Bearing Compass.**—A compass provided with means for taking bearings.
- Magnetic Belting.**—A method of driving machinery in which the belt is provided at frequent intervals with strips of sheet iron riveted to it perpendicularly to its length and the iron driving pulley magnetized, so that the magnetic attraction increases the friction or grip on the pulley.
- Magnetic Blow-Out.**—(1) A device for extinguishing an arc by an electro-magnet. (2) A device employed for extinguishing an arc formed between the contact pieces of a street-car controller, or other similar device, by means of the flux produced by an electro-magnet which is placed in the circuit of the current producing the arc.

- Magnetic Blow-Out Lightning-Arrester.**—A lightning arrester in which the arc, when formed, is blown out by the action of the flux of an electro-magnet placed in the circuit of the arc.
- Magnetic Bridge.**—An apparatus for measuring magnetic resistance, similar in principle to Wheatstone's electric bridge.
- Magnetic Centre of Gravity.**—A conception respecting the existence of a point from which the magnetic flux producing a magnet pole issues, similar to the conception of a centre of gravity in an unequally loaded plane.
- Magnetic Circuit.**—The path through which magnetic flux passes.
- Magnetic Circuit-Breaker.**—A circuit breaker operated by means of an electro-magnet.
- Magnetic Circuit-Closer.**—A circuit closer operated by means of an electro-magnet.
- Magnetic Closed-Circuit.**—A ferro-magnetic circuit.
- Magnetic Clutch.**—(1) A form of clutch in which magnetic attraction is substituted for ordinary mechanical force, to obtain the friction required in the clutch. (2) A clutch operated electro-magnetically.
- Magnetic Coercivity.**—A term sometimes used for coercive force.
- Magnetic Compensator.**—A device for neutralizing the effects produced by the local magnetism of a ship on a magnetic needle.
- Magnetic Concentration.**—The separation of the useful ore from the dross in low-grade ores, by the use of an electro-magnetic separator.
- Magnetic Conduction - Current.**—(1) Time-rate of increase of magnetic flux through a boundary. (2) Time-rate of flow of magnetism.
- Magnetic Conductivity.**—Magnetic permeability.
- Magnetic Connection.**—(1) A term sometimes employed for inductive connection. (2) The connection of one circuit with another by means of inter-linked magnetic flux.
- Magnetic Control of Galvanometer Needle.**—The alteration in the sensibility of a galvanometer needle effected by means of a compensating magnet.
- Magnetic Couple.**—The couple which turns or tends to turn a magnetic needle, placed in the earth's field, into the plane of the magnetic meridian.
- Magnetic Creeping.**—A term used for a gradual increase in the magnetization, following a sudden increase in magnetizing force.
- Magnetic Cross-Flux of Transformer.**—A magnetic flux across the direction of main or working flux and representing magnetic leakage.
- Magnetic Current.**—The time-rate of increase of magnetic flux through a surface.
- Magnetic Curve-Tracer.**—An instrument for graphically recording the variations of magnetic intensity in a mass of iron subjected to cyclic variations of magnetizing force.
- Magnetic Curves.**—(1) Curved lines extending in the direction of the flux-paths of a magnetic field, obtained by gently tapping a sheet of paper or glass sprinkled with iron filings and held in the field. (2) Magnetic figures.
- Magnetic Cycle.**—A cycle of magnetization.
- Magnetic Day of Disturbance.**—A day of magnetic disturbance.
- Magnetic Declination.**—The variation of a magnetic needle from the true geographical north.
- Magnetic Deep-Sea Thermometer.**—A deep-sea thermometer containing small steel maximum and minimum limit markers which are reset by a permanent magnet.
- Magnetic Density.**—The strength of magnetism as measured by the amount of magnetic flux which passes through unit area of normal cross-section. (2) Intensity of magnetic induction.
- Magnetic Deviation.**—(1) The local magnetic variation due to the presence of iron in the vicinity, as distinguished from the true magnetic variation of the locality considered. (2) On board ship, that part of the total magnetic variation due to iron in or on board the ship.
- Magnetic Diffusion.**—Magnetic leakage.
- Magnetic Dip.**—(1) The deviation of a freely suspended magnetic needle from a true horizontal position. (2) The magnetic inclination.
- Magnetic Discontinuity.**—The more or less marked change in the permeability of a magnetic circuit produced by any joint in such circuit.
- Magnetic Displacement.**—(1) An imaginary stress in the ether when subjected to magnetization and corresponding to electric displacement in electrostatics. (2) Magnetic induction.

- Magnetic Dissymmetry.**—(1) A lack of uniformity of the magnetic flux in a magnetic circuit, or in portions of that circuit. (2) A lack of uniformity produced in the flux through the armature core of a dynamo or motor during its operation.
- Magnetic Disturbance.**—A term sometimes employed for temporary variations in the intensity of the earth's magnetism.
- Magnetic Divining Rod.**—A small dipping needle employed for the purpose of locating approximately the position of beds of iron ore.
- Magnetic Effluvia.**—(1) A term employed in the early history of magnetism for assumed imponderable effluvia which were supposed to be given off by magnets. (2) Magnetic flux.
- Magnetic Elements of a Place.**—The values of the magnetic intensity, the magnetic declination or variation, and the magnetic inclination or dip of any place.
- Magnetic Equalizer.**—A device for equalizing the otherwise unequal force exerted between a magnet pole and its armature at varying distances.
- Magnetic Equator.**—(1) The line connecting places on the earth's surface where a magnetic needle remains horizontal, when suspended so as to be free to move in a vertical as well as in a horizontal plane. (2) An irregular line passing around the earth, approximately midway between its magnetic poles.
- Magnetic Excitation.**—Magnetization.
- Magnetic Explorer.**—(1) A small flat coil of insulated wire, used, in connection with the circuit of a galvanometer or telephone, to determine the position and extent of the magnetic leakage of a dynamo, or other similar apparatus. (2) A search coil so connected to a ballistic galvanometer that its movements through magnetic flux will be indicated by the galvanometer.
- Magnetic Fatigue.**—An increase in the hysteretic coefficient of iron due to an assumed fatigue after many cyclic reversals.
- Magnetic Fatigue of Transformer.**—(1) An increase in the hysteretic loss of a transformer with time. (2) The ageing of a transformer core.
- Magnetic Field.**—(1) The region of magnetic influence surrounding the poles of a magnet. (2) The space or region traversed by magnetic flux. (3) A space traversed by magnetic flux in which a magnet needle, free to move, will assume a definite position.
- Magnetic Figures.**—A name sometimes applied to the groupings of iron filings obtained when a sheet of paper or glass, sprinkled with filings, is so held in a magnetic field as to permit the filings to be grouped or arranged under the influence of the magnetic flux.
- Magnetic Filament.**—A polarized line or chain of ultimate magnetic particles.
- Magnetic Flow.**—A term sometimes employed for magnetic flux.
- Magnetic Fluids.**—A term formerly employed for the assumed fluids which were believed to be the cause of magnetic phenomena.
- Magnetic Austral Fluid.**—The assumed magnetic fluid existing at the south pole of any magnet.
- Magnetic Boreal Fluid.**—The assumed magnetic fluid existing at the north pole of any magnet.
- Magnetic Flux.**—(1) The streamings that issue from and return to the poles of a magnet. (2) The total number of lines of magnetic force in any magnetic field. (3) The magnetic flow that passes through any magnetic circuit.
- Magnetic Flux-Density.**—The quantity of magnetic flux in any part of a magnetic circuit per-unit-of-area of normal cross-section.
- Magnetic Flux-Intensity.**—The density of magnetic flux.
- Magnetic Flux-Paths.**—Paths taken by magnetic flux in any magnetic circuit.
- Magnetic Force.**—The force which causes the attractions and repulsions of magnetic poles.
- Magnetic Friction.**—A term sometimes used for magnetic hysteresis.
- Magnetic Fringe at Edge of Dynamo Pole-Pieces.**—The lateral dispersion or diffusion of magnetic flux through the air space which produces an apparent fringe of magnetic flux in the air surrounding the poles.
- Magnetic Gearing.**—A form of friction gearing employing magnetic adhesion.
- Magnetic Generator.**—A magneto-electric generator.
- Magnetic Helix.**—A magnetizing coil.
- Magnetic Hysteresis.**—(1) Apparent molecular friction due to magnetic change of stress. (2) A lagging of magnetization behind the magnetic force producing it. (3) That quality of a magnetic substance

- in virtue of which energy is absorbed on the reversal of its magnetization.
- Magnetic Image.**—The analogue in magnetism of an electric image in electrostatics.
- Magnetic Impermeability.**—A term sometimes used for magnetic reluctivity.
- Magnetic Inclination.**—(1) The angular deviation from a horizontal position of a freely suspended magnetic needle. (2) Magnetic dip.
- Magnetic Induction.**—(1) In air, the density of magnetic force; in iron or other magnetic material the sum of the prime flux, or magnetic force, and the magnetic flux thereby produced in the iron. (2) Total magnetic flux-density. (3) The production of magnetism in a magnetizable substance on its being brought into magnetic flux.
- Magnetic Inertia.**—The inability of a magnetic core to instantly lose or acquire magnetism.
- Magnetic Intensity.**—(1) Magnetic flux-density. (2) The quantity of magnetic flux per-unit-of-area of normal cross-section. (3) Magnetic induction.
- Magnetic Joint.**—A joint effected between contiguous pieces of iron forming portions of a magnetic circuit.
- Magnetic Lag.**—(1) Magnetic viscosity manifested by the sluggishness with which a magnetizing force produces its magnetizing effects in a mass of iron. (2) The tendency of an iron core to resist, and, therefore, to retard its magnetization. (3) Hysteresis in iron.
- Magnetic Lag Motor.**—A form of motor whose torque depends on magnetic lag or hysteresis.
- Magnetic Latitude.**—(1) The meridional angular distance of a place north or south of the magnetic equator. (2) The latitude as deduced from the magnetic dip.
- Magnetic Leakage.**—(1) A useless dispersion of magnetic flux of a dynamo or motor by its failure to pass through the armature. (2) Any useless dispersion of magnetic flux by its failure to pass through a magneto-receptive device placed in the magnetic circuit.
- Magnetic Leakage Factor.**—The ratio of the total flux generated in a magnetic circuit to the quantity usefully passing through an armature or magneto-receptive device.
- Magnetic Lightning-Arrester.**—(1) An electro-magnetic blow-out lightning-arrester. (2) Any lightning-arrester employing an electro-magnet.
- Magnetic Limbs.**—(1) Magnetic cores. (2) Magnetic arms.
- Magnetic Limit.**—A term sometimes employed for the temperature at which a magnetic substance loses its magnetism on exposure to heat.
- Magnetic Line-Protector.**—An electromagnetic device placed on a telegraphic or other line for the purpose of protecting its instruments from lightning discharges.
- Magnetic Lines of Force.**—(1) Lines of magnetic force. (2) Flux paths. (3) The lines along which a free magnetic pole would be urged.
- Magnetic Magazine.**—A term sometimes employed for a compound magnet. (Obsolete.)
- Magnetic Mass.**—The quantity of magnetism or imaginary magnetic matter resident on a polar surface.
- Magnetic Memory.**—(1) That deviation of a magnetic condition of a magnetic substance from the complete response to an impressed magnetic force which is a function of antecedent magnetic states. (2) A term proposed for magnetic retentivity. (3) The power possessed by a magnetic substance, in virtue of hysteresis, to retain in any magnetic state, the history of antecedent states.
- Magnetic Meridian.**—(1) The great circle which passes through a place and through the poles of a magnetic needle at that place, when in a position of rest under the free influence of the earth's magnetism. (2) The terrestrial great circle coinciding in plane with the direction of the earth's local magnetic force.
- Magnetic Moment.**—(1) The product of the strength of one of the poles of a magnet into the distance between them. (2) The sum of the two forces of the directive couple of a magnet multiplied by half the perpendicular distance between the directions of these forces. (3) The length of a magnet multiplied by the intensity of one of its poles.
- Magnetic Needle.**—(1) A magnetized steel needle, or thin straight strip or rod. (2) A straight bar of magnetized steel, supported at or above its centre of gravity, and free to move in a horizontal plane only, in a vertical plane only, or in both.
- Magnetic North.**—That point of the horizon which is indicated by the north-seeking pole of a magnet.
- Magnetic Observatory.**—An observatory in which observations are made of the

- variations in the direction and intensity of the earth's magnetic field.
- Magnetic Oscillation.**—A magnetic vibration, or to-and-fro variation.
- Magnetic Output.**—The product of the magnetic flux produced by any source and its magneto-motive force.
- Magnetic Parallels.**—Lines connecting places on the earth's surface at right angles to the isogonal lines, or lines of equal declination or variation.
- Magnetic Permeability.**—(1) Conductivity for magnetic flux. (2) The ratio between the magnetic induction produced in a magnetic substance, and the magnetizing force producing such magnetic induction.
- Magnetic Permeance.**—Magnetic permeability.
- Magnetic Permeation.**—The passage of magnetic flux through any permeable substance.
- Magnetic Perturbations.**—Abnormal magnetic variations, or disturbances.
- Magnetic Phantom.**—A term sometimes employed for magnetic figures.
- Magnetic Points of Convergence.**—The magnetic paths of the earth around which the isogonic lines are drawn.
- Magnetic Polar-Area.**—The active area of the pole-pieces of a magnet.
- Magnetic Polar-Intensity.**—The intensity of the magnetic flux produced at the pole-pieces of a magnet.
- Magnetic Polarization.**—That condition of a magnetizable substance when it is subjected to polarization.
- Magnetic Polar-Surface.**—The magnetic polar area.
- Magnetic Polarity.**—Polarity acquired by a magnetizable substance when brought into magnetic flux.
- Magnetic Poles.**—Those parts of a magnetic source from or at which the flux emerges or enters.
- Magnetic Potential.**—(1) That property of any space by virtue of which magnetic work is done when a magnet pole is moved therein. (2) The amount of work required to bring up a unit north-seeking magnetic pole from an infinite distance to a given point in a magnetic field. (3) The line integral of magnetic force on a unit pole in coming from an infinite distance to the point considered.
- Magnetic Proof-Piece.**—A magnetized ellipsoidal or square rod employed for ascertaining the distribution of magnetism over a magnet by the force required to detach the same.
- Magnetic Proof-Plane.**—A small coil of wire placed in the circuit of a delicate galvanometer, and used for exploring a magnetic field.
- Magnetic Reactance.**—In an alternating-current circuit the reactance of a coil as distinguished from the reactance of a condenser.
- Magnetic Reluctance.**—The resistance offered by a medium to the passage through it of magnetic flux.
- Magnetic Remanence.**—The magnetic flux-density left in iron or other magnetic substance after the removal of a magnetizing force.
- Magnetic Repulsion.**—Mutual repulsion exerted between two similar magnet poles.
- Magnetic Resistance.**—A term formerly used for magnetic reluctance.
- Magnetic Resistivity.**—(1) Magnetic reluctance. (2) The reluctance of a medium referred to the reluctance offered between parallel faces of a unit cube. (3) The magnetic analogue of electric resistivity.
- Magnetic Retardation.**—A retardation in the magnetization or demagnetization of a substance due to magnetic lag.
- Magnetic Retentiveness.**—A name sometimes applied to magnetic retentivity.
- Magnetic Retentivity.**—(1) The resistance a body offers to change of magnetization. (2) Hysteretic retention of magnetism when the magnetizing force is changed or wholly withdrawn. (3) That quality of iron or other magnetic substance in virtue of which it retains its magnetic flux after the withdrawal of the magnetizing force. (4) Magnetic remanence.
- Magnetic Ringer.**—A magnetic call-bell.
- Magnetic Rotary-Polarization.**—(1) Rotary polarization of a beam of plane polarized light, produced by its passage through magnetic flux. (2) Magneto-optic rotation.
- Magnetic Safety Factor.**—The factor of safety of demagnetization.
- Magnetic Saturation.**—(1) The maximum magnetization which can be imparted to a magnetic substance. (2) The condition of iron, or other magnetic substance, when its intensity of magnetization is so great that it fails to be further magnetized by any magnetizing force, however great.
- Magnetic Screen.**—(1) A hollow box whose sides are made of thick iron placed

- around a magnet or other body, so as to shield its interior from a magnetic field external to the box. (2) A magnetic shield.
- Magnetic Screening.**—Preventing magnetic induction from taking place by interposing either a thick iron plate, or a plate of good conducting material, between the body producing the magnetic field and the body to be magnetically screened.
- Magnetic Self-Induction.**—(1) Electro-magnetic self-induction. (2) The power possessed by a magnet of inducing an opposite polarity in its own particles. (3) Self-demagnetizing power in a magnet.
- Magnetic Sense.**—A name sometimes applied to the assumed sense by means of which magnetic influences are claimed to be perceived.
- Magnetic Shade.**—A term sometimes used for a magnetic screen.
- Magnetic Shells.**—Sheets or layers consisting of magnetic particles in each of which all the north poles are situated in one of the flat surfaces of the layer, and all the south poles in the opposite surface.
- Magnetic Shield for Watches.**—A hollow case of iron in which a watch is permanently kept in order to partially shield it from the influence of external magnetic flux.
- Magnetic Shunt.**—An additional path of magnetic material provided in a magnetic circuit for the passage of magnetic flux.
- Magnetic Shunt-Circuit.**—An additional or branch circuit through which some of the flux is diverted from the main magnetic circuit.
- Magnetic Shunt-Transformer.**—(1) A transformer provided with a magnetic shunt of regulable value, for the purpose of regulation. (2) A transformer situated in a magnetic shunt.
- Magnetic-Siren Telephone-Call.**—A magnetophone employed as a telephone call.
- Magnetic Solenoid.**—A spiral coil of wire, which acts like a magnet when an electric current is sent through it.
- Magnetic Sounds.**—Faint clicks heard on the magnetization and demagnetization of a readily magnetizable substance.
- Magnetic Source.**—Anything capable of producing magnetic flux.
- Magnetic Spectrum.**—(1) A term sometimes employed in place of magnetic figures or a magnetic field. (2) The succession of bright and dark fluorescent bands produced upon a suitable screen in a Crookes tube when the cathode rays are deflected by magnetic flux.
- Magnetic Spin.**—A term sometimes employed for magnetic field.
- Magnetic Spiral.**—A magnetizing spiral or helix.
- Magnetic Sticking of Armature.**—The magnetic adhesion of the armature to the magnet poles under the influence of hysteresis.
- Magnetic Storm.**—(1) Any unusually marked irregularity occurring in the distribution of the earth's magnetism resulting in a variation in the value of its magnetic elements. (2) A comparatively violent and widespread temporary perturbation of the earth's magnetic elements in some way associated with solar disturbances and electric earth currents.
- Magnetic Strain.**—The result of subjecting any medium to magnetic stress or magnetic flux.
- Magnetic Stream-Lines.**—(1) Magnetic flux-paths. (2) Lines of magnetic flux. (3) The curved paths along which a free magnetic pole would be urged in different parts of the field.
- Magnetic Stress.**—(1) The mechanical stress exerted by the attraction of magnetized bodies. (2) That property of flux which produces magnetic strain or magnetic phenomena in bodies subjected to its influence.
- Magnetic Susceptibility.**—(1) The ratio existing between the induced magnetization and the magnetizing force producing such magnetization. (2) The intensity of magnetism divided by the magnetic force.
- Magnetic Telephone.**—(1) A name sometimes given to an electro-magnetic telephone. (2) A magneto telephone.
- Magnetic Telephone-Transmitter or Receiver.**—A magneto-telephone-transmitter or receiver.
- Magnetic Theodolite.**—An apparatus for measuring the declination or variation of the magnetic needle at any place.
- Magnetic Tick.**—(1) A metallic click heard on the magnetization and demagnetization of a bar of iron or steel. (2) The Page effect.
- Magnetic Time-Constant.**—In an electric circuit or conductor, the ratio of the inductance to the resistance, usually expressed in henrys per ohm, or seconds.
- Magnetic Traction.**—(1) Tractive or supporting power exerted by a magnet. (2) Hauling or carrying effected magnetically.

Magnetic Unit Pole.—An imaginary free magnetic pole situated at a point, of such strength that it would act with a force of a dyne on a similar unit pole distant from it one centimetre.

Magnetic Units.—(1) Units based on the force exerted between magnet poles. (2) Units employed in dealing with magnets and magnetic phenomena. (3) The magnetic system of C. G. S. electro-magnetic units, as distinguished from the electrostatic system.

Magnetic-Vane Ammeter.—An ammeter in which the strength of a magnetic field produced by the current that is to be measured is determined by the repulsion exerted between a fixed and a movable iron vane placed inside the field and magnetized thereby.

Magnetic-Vane Voltmeter.—A voltmeter in which the potential difference is measured by the repulsion exerted between a fixed and a movable vane of soft iron placed within the field of the magnetizing coil.

Magnetic Variations.—Variations in the value of the magnetic elements of a place.

Magnetic Variation-Transit.—An apparatus for measuring the magnetic declination or variation at any place.

Magnetic Variometer.—An instrument for comparing the horizontal component of the earth's magnetism at different localities.

Magnetic Viscosity.—A property of iron or other paramagnetic substance in virtue of which a certain time is required before a given magnetizing force can produce its full effects.

Magnetic Voltmeter.—(1) An instrument in which the magnetic field of a current proportional to the difference of potential to be measured deflects a movable needle against the action of the field of a magnet. (2) A voltmeter employing a permanent magnet.

Magnetic Vortices.—Imaginary vortices in the ether postulated to account for magnetic phenomena.

Magnetics.—A word sometimes used for that branch of science which treats of the laws and phenomena of magnetism.

Magnetician.—A word proposed for one skilled in the science of magnetism.

Magnetification.—The production of magnetism in any body.

Magnetine.—A word formerly applied for the assumed principle of magnetism; *i.e.*, the imponderable, hypothetical fluid to

the presence of which magnetic phenomena were believed to be due.

Magnetisation.—An orthography sometimes used for magnetization, and in similar words where the *z* is replaced by *s*.

Magnetish.—Possessing the property of magnetism to a limited degree. (Very rarely used.)

Magnetism.—(1) That property or condition of matter which accompanies the production of magnetic flux. (2) Magnetic flux or streamings. (3) That branch of science which treats of the nature and properties of magnets and of magnetic flux.

Magnetism of Rotation.—A conception at one time entertained that revolving bodies became magnetized, as a deduction from Arago's experiment.

Magnetist.—A magnetician. (Seldom used.)

Magnetite.—A name given to mineral magnetic oxide of iron.

Magnetizability.—Possessing the ability of becoming magnetized.

Magnetizable.—Capable of being magnetized.

Magnetization.—The act of imparting or acquiring magnetization.

Magnetization by Double-Touch.—A magnetization effected by placing two magnets with their opposite poles together on the middle of the bar to be magnetized, moving them to one end of the bar, then moving them over the surface of the bar to the other end, and continuing these to-and-fro movements a number of times, observing to stop in the middle of the bar, and when the magnetizing magnets are moving in the opposite direction to that in which they began to move.

Magnetization by Separate-Touch.—Magnetization obtained by placing two magnetizing bars with their opposite poles at the middle of the bar to be magnetized, drawing them away from each other towards its ends, returning them through the air to the middle of the magnet, and repeating this a number of times.

Magnetization by Touch.—The production of magnetic poles in a magnetizable substance by touching it with a magnet.

Magnetization Curves.—Curves which graphically represent the relation of a magnetizing force to the intensity of magnetization or to the magnetic flux.

Magnetization Cycle.—(1) A cycle of magnetization. (2) A succession of mag-

- netic states which terminate in the original state.
- Magnetize.**—To endow with the property of magnetism.
- Magnetized.**—Endowed with the property of magnetism.
- Magnetizee.**—A word proposed to designate a person who believes he is placed under the power of animal magnetism.
- Magnetizer.**—(1) One who, or that which, magnetizes. (2) A word proposed to designate a person who claims that he can place another under the power of his animal magnetism.
- Magnetizing.**—Endowing a body with magnetic qualities.
- Magnetizing Ampere-Turns.**—The ampere-turns of a magnetizing coil.
- Magnetizing Currents.**—Currents that are employed in producing magnetization.
- Magnetizing Flux.**—Flux which is intended to magnetize a body, or to keep it magnetized, as distinguished from magnetic flux which performs any other functions.
- Magnetizing Force.**—(1) The vector space-rate of descent of magnetic potential. (2) The prime flux-density impressed upon a body, and which may induce magnetism in the same. (3) The force at any point with which a unit magnetic pole would be acted on. (4) The impressed flux-density of a field as distinguished from the total flux-density.
- Magnetizing Helix.**—A magnetizing spiral or solenoid.
- Magnetizing Spiral.**—A magnetizing helix or solenoid.
- Magnetizing Turn.**—A single turn in a magnetizing coil.
- Magneto.**—(1) A magneto-generator. (2) A small magneto-electric dynamo machine.
- Magneto-Alternator.**—An alternator whose field flux is produced by permanent magnets.
- Magneto-Blasting Machine.**—A magneto-electric machine employed for generating the currents used in electric blasting.
- Magneto Call-Bell.**—A call-bell operated by a magneto-electric machine.
- Magneto-Chemical Cell.**—A cell, the voltaic couple of which consists of two magnetized steel bars, whose north and south poles are respectively immersed in a solution of oxalic acid.
- Magnetod.**—A name employed by Reich-
- enbach for the assumed force or principle of animal magnetism.
- Magneto-Dynamic Force.**—The force exerted between magnets, or between magnets and electric currents.
- Magneto-Dynamics.**—That branch of dynamics which treats of the influence of magnet poles on one another.
- Magneto-Electric Alternating Machine.**—A magneto-alternator.
- Magneto-Electric Bell.**—An electric bell whose actuating current is obtained from a magneto-electric machine.
- Magneto-Electric Brake.**—(1) A device for checking the swing of a galvanometer consisting of means for sending slight inverse currents through the coils of the galvanometer. (2) An electro-magnetic brake.
- Magneto-Electric Call-Bell.**—A call-bell operated by a magneto-electric machine.
- Magneto-Electric Dynamo.**—A dynamo-electric machine whose field magnets are formed of permanent magnets.
- Magneto-Electric Faradic Apparatus.**—A small magneto-electric machine employed in electro-therapeutics for producing faradic currents.
- Magneto-Electric Force.**—A theoretically-assumed mechanical force exerted between a magnetic current and an electric field, corresponding to the electro-magnetic force known to be exerted between an electric current and a magnetic field.
- Magneto-Electric Generator.**—A magneto-generator.
- Magneto-Electric Induction.**—A variety of electro-dynamic induction in which electric currents are produced by the motion of permanent magnets past conductors, or of conductors past permanent magnets.
- Magneto-Electric Key.**—A telegraphic key so arranged that a coil of wire on an armature connected with a key lever, through the movements of the key towards and from the poles of a permanent magnet, produces currents that are sent into the line.
- Magneto-Electric Machine.**—A magneto-generator.
- Magneto-Electrical Medical Apparatus.**—A small magneto-alternator employed in medical electricity for the production of alternating or pulsating currents.
- Magneto-Electric Multiplier.**—An early form of induction coil employed by Page.

- Magneto-Electricity.**—(1) Electricity produced by the motion of magnets past conductors or of conductors past magnets. (2) Electricity produced by magneto-electric induction.
- Magneto-Generator.**—A dynamo-electric machine whose field flux is obtained from permanent magnets.
- Magnetogram.**—Any automatic record obtained by means of a magnetic instrument.
- Magnetograph.**—A permanent record obtained by the action of a self-recording magnetometer.
- Magneto-Induction Key.**—A magneto-electric telegraph transmitter so arranged that the movements of a key produce the electric currents that are sent into the line.
- Magneto-Inductor.**—An inductor consisting of a permanent magnet as distinguished from an inductor consisting of an electro-magnet.
- Magneto-Inductive Capacity.**—A term sometimes employed for magnetic permeability.
- Magneto Instrument.**—(1) A name formerly applied to a magneto machine. (2) In telegraphy, a name sometimes employed for a machine operating or operated by magnetically-induced currents.
- Magnetology.**—(1) A name sometimes applied to the science of magnetism. (Not in general use.) (2) That branch of science which treats of magnetism. (Very seldom used.)
- Magnetometer.**—(1) An apparatus for the measurement of magnetic force. (2) Any apparatus for measuring the elements of the earth's magnetic force.
- Magnetometric.**—Of or pertaining to a magnetometer.
- Magnetometry.**—That branch of science which treats of the measurement of the strength of magnetic fields.
- Magneto-Motive.**—Producing magnetic effects.
- Magneto-Motive Force.**—(1) The force which produces magnetic flux. (2) The force that moves or tends to move magnetic flux.
- Magneto-Motive Intensity.**—A term sometimes used for the slope of magneto-motive force.
- Magneto-Motor.**—(1) A term formerly applied to a voltaic battery coupled in parallel. (2) A motor whose field is produced by permanent magnets.
- Magneto-Optic Rotation.**—A rotation of the plane of polarization of a beam of plane polarized light on its passage through a transparent medium, when placed in a strong magnetic field in the direction of the beam.
- Magnetophone.**—A species of magnetic siren with which sounds are produced in a telephone by the periodic currents produced in its coils by the rotation of a perforated metallic disc in a magnetic field.
- Magneto-Pointer.**—A dial of a printing telegraph.
- Magneto-Polar.**—Possessing magnetic polarity.
- Magneto-Receptive Device.**—A device that is capable of being energized when placed in magnetic flux.
- Magnetoscope.**—Any apparatus for the detection of the presence of magnetism, but not for measuring it.
- Magneto-Signals.**—Any signals operated by a magneto-electric machine.
- Magneto-Static Ammeter.**—An ammeter whose magnet is acted on by a uniform field of force with two coils, while attracted by two systems of powerful permanent magnets.
- Magneto-Static Current-Meter.**—A magneto-static ammeter.
- Magneto-Static Screening.**—Screening from the inductive effects of a stationary magnetic field.
- Magneto-Statics.**—The science which treats of magnetic forces at rest.
- Magneto-Tapper.**—(1) A term sometimes employed for a magneto-key. (2) A contact key which closes the circuit of a magneto.
- Magneto-Telephone Transmitter.**—A telephone transmitter formed of a powerful compound magnet provided with a coil of insulated wire supported in front of one of its poles, and an iron core forming the pole-piece of the magnet.
- Magneto-Therapy.**—Alleged electro-therapeutic effects produced by the application of magnets to the human body.
- Magnet Wire.**—Insulated wire suitable for winding magnets and usually cotton-covered.
- Magpie Cable.**—A name given to a form of telephone cable in which the wires or conductors are arranged in double pairs.
- Main Battery.**—The battery employed in telegraphic systems for sending the signals over the main line, as distinguished from a battery employed for any other work.
- Main-Battery Circuit.**—(1) A term sometimes used for line circuit. (2) The cir-

- cuit of the main battery in any conducting system.
- Main-Circuit Fuse.**—A safety fuse provided for the protection of the main circuit.
- Main-Circuit Switch.**—A switch inserted in a main circuit.
- Main Cut-Out.**—Any cut-out placed in the circuit of a main.
- Main Feeder.**—(1) The feeder to which the standard pressure-indicator is connected, and whose pressure controls the pressure at the ends of all the other feeders. (2) A standard feeder. (3) A principal feeder supplying a group of sub-feeders.
- Main Fuse.**—A main-circuit fuse.
- Main-Line-Circuit Switch.**—A main switch.
- Main-Line Cut-Out.**—A main cut-out.
- Main-Line Relay.**—A relay suitable for use in connection with a main telegraphic line.
- Main-Line Sounder.**—A sounder suitable for use in connection with a main telegraphic line.
- Main Switch.**—(1) A switch connected with the electric mains. (2) A principal switch controlling a group of subsidiary switches. (3) A main-line-circuit switch.
- Main Telegraphic-Circuit.**—The principal or line telegraphic circuit.
- Main Telegraphic-Current.**—The current employed on a main telegraphic line or circuit.
- Main Terminals of Machine.**—(1) The principal terminals of a machine. (2) The terminals connected with the external circuit of a machine.
- Main-to-Dynamo Bonding.**—A phrase employed for a method of bonding of the rails in an electric car system, in which the bonding is between a positive water main, or buried metallic system, and the negative terminal of the dynamo.
- Main-to-Track Bonding.**—A phrase employed for a method of bonding of the rails in an electric car system in which the bonding is between a positive water main and a negative track.
- Main-Trunk Telephone-Line.**—(1) A main telephone line connecting two cities and usually erected with considerable care, as to conducting power, insulation, and freedom from electrical disturbance, so as to serve as a general link of communication either for communication between those cities, or for communication through those cities. (2) A term used in contradistinction to a local telephone line connecting two stations.
- Main Tubes.**—The tubes in an underground system, provided for the mains.
- Main Voltmeter.**—(1) A voltmeter in a central station connected with the mains. (2) A principal or standard voltmeter.
- Main Wire.**—(1) Wire used in or intended for electric mains. (2) Wire constituting part of an electric main. (3) The principal electric conductor in a distribution or conducting system.
- Mains.**—(1) In a parallel system of distribution the parallel conductors carrying the main current, and to which translating devices are connected. (2) In a system of parallel distribution, the principal conductors which extend from the risers, or service wires, along the corridors or passages along the floor to be lighted.
- Mains of Electric Railroads.**—The mains from which the driving current is supplied to the cars.
- Make.**—To complete or close a circuit.
- Make-and-Break.**—The operation of alternately completing and opening a circuit.
- Make-Induced Current.**—(1) The current produced by self-induction on the making or closing of a circuit. (2) The current produced by mutual induction in the secondary of an induction coil or transformer, on the making or completion of the circuit of the primary.
- Making Earth.**—In telegraphy, grounding.
- Making the Primary.**—Closing the circuit of the primary.
- Making-Up Batteries.**—Joining voltaic cells in series or in parallel.
- Manganin.**—A high-resistivity metal of very low resistivity temperature-coefficient.
- Mangin Projector.**—A special form of search-light projector.
- Mangin Reflector.**—A special form of dioptric reflector employed in connection with the Mangin projector, consisting of a circular glass reflector, silvered at the back, and whose inner and outer or front and back surfaces are both spherical.
- Manganin Resistance.**—A resistance made of manganin wires, strips, or sheets.
- Man-Hole Compartment of Conduit.**—A man-hole provided in a conduit for affording access to the same.
- Man-Hole of Conduit.**—An opening communicating from the surface of the road-

bed with an underground conduit, of sufficient size to admit a man.

Manometer.—An apparatus for measuring the tension or pressure of gases.

Manometric.—Of or pertaining to a manometer.

Man-Power.—A unit of power equal to the one-tenth of a horse-power, or about 75 watts.

Manual Alarm.—A fire alarm operated by hand-power.

Manual Igniting Device.—(1) A pendant electric gas-lighting burner. (2) An electric gas igniter operated by hand. (3) A manual mine exploder.

Manual Repeater.—A telegraphic repeater which is controlled or operated by hand, as distinguished from an automatic repeater.

Manual Telegraphic Transmission.—Transmission by hand, as distinguished from automatic or machine transmission.

Manual Translation.—The translation, especially in submarine telegraphy, of a message from one circuit to another, by an operator who transmits to the second circuit, direct from signals received on the first, without writing down or transcribing the messages.

Marconi Rays.—Electro-magnetic waves employed in the Marconi system of wireless telegraphy.

Marconi Waves.—Electromagnetic waves employed in the Marconi system of wireless telegraphy.

Margin of Relay Adjustment.—The range of alteration permissible in the adjustment of the armature of a relay without interfering with the working of the instrument.

Marine Galvanometer.—(1) A form of Thomson reflecting galvanometer, heavily encased in iron, devised for use on steamships where the motion of magnetized masses of iron would seriously disturb the reading of ordinary instruments. (2) Any form of galvanometer suitable for use on board ship.

Marine Junction-Box.—A water-tight junction box for effecting junctions between mains, or mains and branches, on board ship.

Marine Lamp-Socket.—A form of spring socket for flexibly supporting an incandescent lamp on board ship.

Marine Search-Light or Lamp.—An electric search-light suitable for use at sea.

Marine Switch.—A water-tight switch in

an incandescent lamp, fixture, or circuit, on board ship.

Marine Voltmeter.—A form of voltmeter suitable for use on a ship.

Mariner's Compass.—(1) A compass mounted in such a manner as to be serviceable on board ship. (2) A name often applied to an azimuth compass.

Mark Buoy.—In submarine cable work, a buoy moored to the bottom of the sea by a mushroom anchor, and placed to mark a certain position, as distinguished from a cable buoy which is moored to the end of a cable.

Marked End of Magnet.—A name formerly applied to the north-seeking pole of a magnet.

Marked Pole of Magnet.—A term sometimes applied to the north-seeking pole of a magnet.

Markers.—Colored flags or signal lights, usually green, displayed in systems of block railroad-signalling, in order to avoid accident from the train breaking in two.

Marking Current.—The current employed in automatic telegraphy to produce the dots and dashes of the Morse alphabet, as distinguished from the spacing current or that employed to leave spaces between such characters.

Marking Disc.—In a Morse ink-writer, the rotating inking disc, which marks the signals.

Mass.—The quantity of matter contained in a body.

Mass Attraction.—The mutual attraction exerted between masses of matter.

Mass Specific-Resistance.—(1) Specific resistance referred to unit mass instead of unit volume. (2) The resistance taken between the ends of a cylindrical wire of definite length, usually one metre, containing a mass, usually a gramme. (3) The resistance of a metre-gramme.

Massage.—The treatment of the body by kneading, rubbing or friction, for the purpose of effecting changes in its general nutrition.

Mass, Electric.—A mathematical conception for quantities of electricity which are so distributed as to produce electrostatic forces in conformity with the laws of gravitational forces, and, therefore, corresponding to material masses.

Mass Specific Resistance.—(1) The resistance of a known mass of a material; namely, one gramme, in the form of a circular sectioned wire one metre in length. (2) The resistance of a foot-grain.

Mast-Arm for Arc-Lamp.—A movable arm or bracket provided at the top of a pole for the support of a lamp arranged for the ready lowering of the lamp for re-carboning.

Mast Compass.—A compass secured to the mast of a ship, at an elevation sufficient to considerably reduce the component of local attraction from the ship's magnetization.

Master Clock.—A central or controlling clock employed in a system of electric time distribution, from which time is transmitted to the secondary clocks in its circuit.

Mate of Wire in Twisted Pair.—(1) One of the wires of a twisted pair. (2) The conjugate member of a wire in a twisted pair.

Matt.—(1) A word employed in electroplating to designate the appearance presented by an electroplating of silver in which the deposit is interlaced and closely massed together. (2) A fused mass of impure copper employed as the raw material in electrolytic refinement.

Matter.—Anything which occupies space in three dimensions and prevents other matter from simultaneously occupying the same space.

Matter, Electric.—A term formerly applied to the matter which was believed to constitute the effluvia formerly assumed to pass off from an electrified body.

Matteucci's Muscular Pile.—A pile formed by arranging a series of muscles so that their exterior and interior surfaces are alternately connected.

Matthiessen's Metre-Gramme-Standard.—(1) A standard of resistivity or conductivity in metallic wires. (2) The resistance of a wire one metre in length, and of such a diameter as would cause the wire to weigh one gramme. (3) According to the American Institute of Electrical Engineers Committee, the standard established by Matthiessen for a metre-gramme of soft copper, 0.1417 international ohm at 0° C., or 0.1501 international ohm at 15° C.

Matthiessen's Mile-Standard.—A standard of resistance equal to the resistance of one mile of pure copper wire one-sixteenth of an inch in diameter, at 15.5° Cent. (No longer used.)

Matthiessen's Unit of Resistance.—Matthiessen's mile-standard.

Maturing of Call.—In a system of telephony where a number of calls have been received at an exchange and recorded for

execution in order, the time at which any particular call is reached in its order.

Maximum.—(1) Possessing the greatest value. (2) In a continuous succession of values, a value greater than that which precedes or follows it.

Maximum Activity of Motor.—(1) The activity of a motor when working at its greatest possible rate, or the activity when the useful work done is equal to half the energy expended. (2) The full-load activity of a motor. (3) The maximum available activity of a motor.

Maximum Efficiency of Transformer.—The highest efficiency obtainable from a transformer.

Maximum Horizontal Intensity of Light.—The greatest intensity of light emitted by a source in a horizontal direction.

Maximum Magnetization.—A term sometimes used for magnetic saturation.

Maximum Negative-Elongation.—The position of a vibrating body when it is at the extremity of its path on the negative side.

Maximum Positive-Elongation.—The position of a vibrating body when it is at the extremity of its path on the positive side.

Maximum Starting-Current of Motor.—The highest value the starting current of a motor attains.

Maximum Traction Truck.—A form of double car-truck.

Maxwell's Electro-Magnetic Theory of Light.—(1) A hypothesis for the cause of light based on the relations existing between the phenomena of light and those of electro-magnetism. (2) A hypothesis that regards light as a purely electro-magnetic phenomenon.

McIntire's Parallel-Sleeve-Telegraphic Joint.—A joint for telegraphic or other wires, in which the ends to be joined are slipped into sleeves or parallel tubes, which are afterwards filled with solder.

Mean.—(1) Average. (2) A quantity having an intermediate value between others.

Mean Annual Station-Current.—The average current delivered by a station throughout the year.

Mean Current.—(1) The time average of a current strength. (2) In an alternating-current circuit, the time average of a current strength without regard to sign or direction.

Mean Electromotive Force.—(1) The average electromotive force. (2) In an

- alternating-current circuit, the time average of the E. M. F. without regard to sign or direction.
- Mean Horizontal Intensity of Light.**—The average intensity of light in a horizontal plane containing the source.
- Mean Illumination.**—The average illumination.
- Mean Load-Current.**—The average load-current.
- Mean Spherical Candle-Power.**—(1) An average candle-power numerically equal to the total quantity of light emitted by a point source divided by 12.566. (2) The average candle-power of a source taken at all points of the surface of a sphere.
- Mean Spherical Intensity of Light.**—The mean spherical candle-power.
- Mean Quadratic Current.**—A term proposed for the effective strength of an alternating current.
- Mean Thermal Capacity for Heat.**—The average capacity for heat.
- Measurement of Resistance.**—The determination of the value of an electric resistance by any suitable means.
- Measurements, Electric.**—Determinations of the values of the electromotive force, resistance, current, capacity, energy, etc., in any electric circuit or instrument.
- Measuring Current.**—(1) The current by which an electrical measurement is made. (2) A testing current.
- Mechanical Air Pump.**—A mechanical device for exhausting or removing the air from any vessel.
- Mechanical Characteristic of Motor.**—A term sometimes employed for the curve of the torque and speed of a motor as coordinates.
- Mechanical Circuit-Closer.**—(1) Any circuit-closer not operated electrically. (2) An automatic circuit-closer not operated electrically.
- Mechanical Closer.**—A mechanical circuit-closer.
- Mechanical Cut-Out.**—(1) Any cut-out not operated electrically. (2) An automatic cut-out not operated electrically.
- Mechanical Depolarizer of Voltaic Cell.**—A method for removing the gas collected on the negative plate of a voltaic cell by the mechanical agitation of the liquid.
- Mechanical Equivalent of Heat.**—The amount of mechanical energy converted into heat that would be required to raise the temperature of a unit mass of water one degree of the thermometric scale. (2) The quantity of energy mechanically equivalent to one heat unit.
- Mechanical Equivalent of Light.**—The quantity of energy contained in one unit of light.
- Mechanical Frictions of Dynamo.**—The journal, brush and air frictions of a dynamo.
- Mechanical Magnet Lightning-Arrester.**—A mechanical device operated by an electro-magnet for the extinguishment of the arc established by a lightning flash.
- Mechanical Mine.**—A submarine mine that is fired when struck by a passing ship through the action of some contrivance contained within the torpedo itself, and having no connection whatever with the shore.
- Mechanical Recording Meter.**—A mechanically operated recording meter.
- Mechanical Seal.**—A mechanically made seal of the chamber of an incandescent lamp.
- Mechanical Telegraph.**—Any form of telegraphy by which communication is established by mechanical means.
- Mechanical Telegraphic Interrupter.**—A form of mechanical telegraphic sounder for learners, where no battery is required.
- Mechanical Telephone.**—A wire or string telephone, operated by longitudinal vibrations transmitted through a wire or string.
- Mechanical Throwback-Indicator.**—An annunciator drop provided with a drop that is mechanically replaced.
- Mechanical Torpedo.**—A torpedo that is exploded by percussion against any obstacle.
- Mechanical Vibrator.**—(1) A mechanically operated contact-breaker. (2) A mechanical means for obtaining the ejection of the ink from the siphon in a siphon recorder.
- Mechanical Work.**—(1) The product of a force by the distance through which the force acts. (2) The expenditure of energy required for any change in the configuration of a material system.
- Medical Battery.**—A medical induction coil.
- Medical Electrician.**—An electro-therapist.
- Medical Induction-Coil.**—An induction coil used for medical purposes.
- Medical Magneto-Electric Apparatus.**

- A term applied to small magneto-electric machines employed in electro-therapeutics for the production of uncommuted or faradic currents.
- Meg or Mega.**—A prefix for one million times.
- Mega-Dyne.**—One million dynes.
- Mega-Joule.**—One million joules.
- Mega-Lines.**—One million lines.
- Megalscope, Electric.**—An apparatus for the medical exploration of the cavities of the body.
- Mega-Volt.**—One million volts.
- Mega-Weber.**—One million webers.
- Megerg.**—One million ergs.
- Megohm.**—One million ohms.
- Megohm Box.**—A resistance box containing a resistance or resistances equal to a megohm.
- Megohm Galvanometer.**—A galvanometer which gives unit deflection through a resistance of one megohm in circuit with one volt.
- Megohm Mile.**—A unit of linear insulation resistance equal in value to the product of a megohm by a mile, and such as is possessed by a mile of wire, the insulation of which is one megohm.
- Melting Points of Metals.**—Temperatures at which metals fuse.
- Membrane Diffusion.**—Osmose.
- Membrane Telephone-Receiver.**—An early form of telephone receiver whose diaphragm was formed of a sheet of gold-beater's skin.
- Mercurial Air-Pump.**—(1) A device for obtaining a high vacuum by the use of mercury. (2) The Geissler or Sprengel mercury pumps.
- Mercurial Connection.**—A form of readily adjustable connection obtained by providing the poles of one piece of apparatus with cups or cavities filled with mercury, in which the terminals of another piece of apparatus are dipped, in order readily to place them in circuit with each other.
- Mercurial Contact.**—An electric contact effected through the medium of mercury.
- Mercurial Phosphorescence.**—A term formerly employed for the light produced by the motion of a column of mercury in an exhausted tube.
- Mercurial Temperature - Alarm.**—An instrument for automatically telegraphing an alarm by means of a mercurial contact, on a pre-determined change of temperature.
- Mercurial Thermostat.**—A thermostat operating by the expansion of a mercury column.
- Mercury Break.**—A form of circuit breaker operated by the removal of a conductor from a mercurial surface.
- Mercurial Commutation.**—A change in the direction of a current obtained by means of a mercurial connection.
- Mercury Cup.**—A cup partly filled with mercury employed as a mercurial contact.
- Mercury Gauge.**—A vacuum or pressure gauge whose indications are dependent on the height of a mercury column.
- Mercury Piezometer.**—An instrument employed in cable work for measuring the depth of the ocean, by recording the pressure at the lowest point reached by the sounding lead, and used as a check upon the length of sounding line.
- Mercury Switchboard.**—A switchboard in which connections are effected by mercurial contacts.
- Mercury Tube.**—(1) A sealed glass tube containing mercury arranged to emit fluorescent light when agitated. (2) A resistance formed of a thread of mercury contained in a tube.
- Meridional.**—Of or pertaining to a meridian.
- Mesh Grouping of Polyphase Circuit.**—A triangular or delta-connection of three-phase coils as distinguished from a star connection.
- Message Wire.**—A line or wire employed in block systems for railroads extending along the road and used for local telegraphic business.
- Messenger Call-Box.**—A district call-box.
- Messenger Rope.**—(1) In cable-work a rope drive for operating a drum or winch at a distance. (2) A rope supporting guide sheaves.
- Messenger Strand.**—A strand in a messenger wire.
- Messenger Wire of Aerial Cable.**—The supporting wire or rope from which the cable clips employed in the suspension of an aerial cable are supported.
- Metal-Cased Blake Transmitter.**—A form of telephone transmitter provided with a metallic covering.
- Metallic.**—Of or pertaining to a metal.
- Metallic Arc.**—An arc formed between metallic electrodes.
- Metallic Circuit.**—A circuit which is metallic throughout, in contradistinction to an earth-return circuit.

- Metallic-Circuit Plug.**—In a telephone switchboard, a plug which makes contact both at its tip and at its sleeve, so as to close a double or metallic circuit connected therewith by a twin cord.
- Metallic Coating.**—An electrolytically deposited coating of metal.
- Metallic Connection.**—Connection by means of a metallic conductor.
- Metallic Conducting Joint.**—A joint in a conductor in which a continuity of conducting power is secured.
- Metallic Conduction.**—The conduction of electricity through a metal, in contradistinction to its conduction through an electrolyte.
- Metallic Conductor.**—A conductor formed of a metal.
- Metallic Contact.**—(1) A contact of a metallic conductor obtained by bringing it into firm connection with another metallic conductor. (2) Contact between metal and metal.
- Metallic Contact of Cable.**—A complete contact between the copper conductor of a submarine cable and its metallic sheath.
- Metallic Cross.**—A fault due to the actual contact between two or more wires or conductors, so that the current from one line passes to another.
- Metallic Electric Conduction.**—(1) A conduction of electric energy by means of metallic substances. (2) Metallic conduction.
- Metallic Electrodes.**—Variously shaped pieces of metal employed for electrotherapeutic electrodes.
- Metallic Electrolysis.**—A form of cathaphoretic medication in which a metallic electrode, connected to the positive pole of a continuous-current source, is brought into contact with the part to be treated, while the negative pole is applied to some other part of the body, and the metallic salt formed by electrolysis at the anode is cathaphoretically driven into the tissues beneath the electrode.
- Metallic Filament.**—A metallic wire employed as a filament of an incandescent lamp.
- Metallic Reluctivity.**—(1) The reluctivity of a metallic substance. (2) In a magnetic substance the reluctivity of the substance as considered independently of the reluctivity of the ether in its mass.
- Metallic Resistance.**—A term sometimes applied to the resistance of wires or conductors, in contradistinction to the resistance of insulating materials.
- Metallic Resistivity.**—The resistivity of a metallic substance.
- Metallic Solution.**—A solution of a metallic salt.
- Metallization.**—Rendering a non-conducting surface electrically conducting by covering it with a metallic coating so as to enable it to be readily electro-plated.
- Metallizing.**—Subjecting to the process of metallization.
- Metallo-Chromes.**—(1) A name sometimes given to Nobili's rings. (2) Prismatic colors which appear when a salt of lead, such as an oxide, is electrolyzed under certain circumstances.
- Metallurgy.**—That branch of science which treats of the reduction or treatment of metallic ores or metals.
- Metamerism.**—(1) A variety of isomerism. (2) The quality possessed by some chemical substances, differing in their properties, although similar in their quantitative composition, owing to a difference of molecular construction or arrangement of atoms in the molecule. (3) A term used in distinction to polymerism.
- Meteorites.**—Fragmentary solids that when attracted to the earth become incandescent on their passage through its atmosphere.
- Meteorograph, Electric.**—An apparatus for automatically registering by electricity various meteorological values such as the indications of a barometer or thermometer, the direction and velocity of the wind, the value of the rain-fall, etc.
- Meteorology.**—That branch of physics which treats of the phenomena of the atmosphere.
- Meteorology, Electric.**—That branch of physics which treats of the electric phenomena of the atmosphere.
- Meter, Electric.**—Any apparatus for measuring commercially the quantity of electricity that passes in a given time through a consumption circuit.
- Meter-Motor.**—(1) A small motor employed in operating an electric meter. (2) A meter comprising a small motor.
- Meter Sealing Tool.**—A tool for stamping a leaden seal which prevents the undesignated opening of a meter by an unauthorized person.
- Method of Recoil.**—A method of measuring a discharge through a ballistic galvanometer by reversing the direction of its swing.
- Method of Slow Discharge.**—An insu-

- lation test for a telegraphic line, based on the rate at which a charge leaks out when the conductor is left insulated.
- Methven Carburetter.**—A device employed in connection with a Methven screen, consisting of troughs of fine wire gauze filled with gasoline, so that the gas passing through becomes charged with the vapor.
- Methven's Screen.**—A vertical rectangular metallic screen used in connection with a standard Argand burner as a photometric standard.
- Metre.**—A unit of length equal, approximately, to one ten-millionth part of a quadrant of a meridian of the earth taken through Paris; or, approximately, to 39.37 inches.
- Metre-Bridge.**—A slide form of Wheatstone's bridge in which the slide wire is one metre in length.
- Metre-Candle.**—(1) The illumination produced by a standard candle at the distance of one metre. (2) A unit of illumination.
- Metre-Gramme.**—(1) A unit of resistance equal to that of the resistance of a wire one metre in length weighing one gramme. (2) A standard of comparison of resistivity or conductivity. (3) Matthiessen's metre-gramme standard of copper wire, which for soft copper wire, according to the committee of the American Institute of Electrical Engineers, is 0.1501 International ohm at 15° C.
- Metre-Millimetre.**—A resistance standard, consisting of a length of wire or other conductor, one metre long and having a diameter of one millimetre.
- Metric Factors.**—The factors employed for the conversion of the metric system units into those of other systems.
- Metric Horse-Power.**—A unit of power in which the rate-of-doing-work is equal to 75 kilogramme-metres per second.
- Metric System of Weights and Measures.**—A system of weights and measures based on the metre and the gramme.
- Mho.**—(1) The practical unit of conductance. (2) Such a conductance as is equal to the reciprocal of one ohm. (3) A unit of electric conductance of the value of 10^{-9} absolute units.
- Mho-Box.**—A conductance box, or box containing adjustable conductance, graduated in mhos.
- Mhometer.**—An instrument for measuring the value of a conductance in mhos.
- Mica.**—(1) A refractory, mineral substance employed as an insulator. (2) A double silicate of alumina or magnesia and potash or soda.
- Micanite.**—A variety of insulating material made from and built up of small mica sheets bound together by some insulating cement.
- Micro.**—A prefix for the one-millionth.
- Micro-Ampere.**—The millionth of an ampere.
- Micro-Coulomb.**—The millionth of a coulomb.
- Micro-Farad.**—The millionth of a farad.
- Micro-Gilb.**—A contraction for microgilbert.
- Micro-Gilbert.**—The millionth of a gilbert.
- Micro Glow-Lamp.**—A miniature incandescent lamp.
- Micro-Graphophone.**—A modification of the phonograph, in which a number of separate non-metallic diaphragms are caused to act on a single diaphragm, for the purpose of obtaining stronger vibrations of the same.
- Micrometer Caliper.**—A micrometer wire gauge.
- Micrometer Eye-Piece.**—An eye-piece of a telescope, microscope or other optical apparatus provided with a micrometer.
- Micrometer Microscope.**—A microscope provided with a micrometer eyepiece.
- Micrometer Wire-Gauge.**—A sensitive form of wire gauge, usually constructed with a fine thread screw, having a graduated head for close measurements of wire diameters.
- Micron.**—A unit of length equal to the millionth part of a meter.
- Microhm.**—The millionth of an ohm.
- Microphone.**—A form of contact telephone-transmitter employed in connection with a telephone for rendering faint or distant sounds distinctly audible.
- Microphone Induction-Coil.**—An induction coil employed in connection with a microphonic telephone transmitter.
- Microphone Relay.**—A device for automatically repeating a telephonic message over another wire.
- Microphonic.**—Of or pertaining to the microphone.
- Microphonic Contact.**—A loose contact capable of being employed for a telephone transmitter.
- Microscope.**—An optical instrument for the examination of objects too minute to be seen by the unaided eye.
- Microscopic.**—(1) Of or pertaining to the

- microscope. (2) Of very minute dimensions.
- Microscopy.**—The art of microscopic examination.
- Micro-Seismograph.**—An electric apparatus for graphically recording the direction and intensity of faint earthquake shocks or earth tremors.
- Micro-Tasimeter.**—An apparatus invented by Edison for measuring minute differences of temperature, or of moisture, by the resulting differences of pressure upon a carbon button.
- Micro-Telephone.**—(1) A convenient form of writing table-set telephone used by some exchange operators in quiet exchanges, or in busy exchanges, at night. (2) A form of combined transmitter and receiver. (3) A small semi-portable telephone set.
- Micro-Volt.**—The one-millionth of a volt.
- Migration of Ions.**—A term employed to express the movement of the ions in an electrolyte undergoing electrolysis.
- Migration Values of Ions.**—The velocities of the ions.
- Mil.**—A unit of length used in measuring the diameter of wires equal to the one-thousandth of an inch.
- Milammeter.**—A milli-ammeter.
- Mild Steel.**—A term employed for soft steel.
- Mil-Foot.**—(1) A resistance standard consisting of a foot of wire, or other conducting material, one mil in diameter. (2) A standard of comparison of resistivity or conductivity of wires.
- Milli.**—A prefix for the one-thousandth part.
- Milli-Ammeter.**—A milli-ampere meter.
- Milli-Ampere.**—The thousandth of an ampere.
- Milli-Ampere Meter.**—An ampere meter graduated to read in milli-amperes.
- Milli-Calorie.**—(1) The thousandth of a calorie. (2) The small calorie.
- Milli-Oersted.**—The thousandth of an oersted.
- Milli-Volt.**—The thousandth of a volt.
- Mimosa Sensitiva.**—A sensitive plant whose leaves fold or shut up, either when touched, or when traversed by electric currents.
- Mine Explorer, Electric.**—A small magneto-electric generator employed in the direct firing of blasts.
- Miniature Incandescent Lamp.**—A very small incandescent lamp, suitable for decorative, microscopic, dental or surgical purposes.
- Mining, Electric.**—The application of electricity to mining.
- Mining Locomotive, Electric.**—An electric locomotive employed in mining operations.
- Minotto's Voltaic Cell.**—A form of Daniells' cell employing a flat copper plate at the bottom of the cell beneath a mass of copper sulphate crystals, the cell being then filled with wet sand, or wet sawdust, on which rests the zinc plate.
- Minus Charge.**—A negative charge.
- Miophone.**—An apparatus, based on the use of the microphone, employed for the medical examination of the muscles.
- Mirror Galvanometer.**—A galvanometer whose readings are obtained by the movements of a spot of light reflected from a mirror attached to the needle or its suspension system.
- Mirror Magnetometer.**—A magnetometer whose needle or suspension system is provided with a mirror.
- Mirror Receiver in Cable Telegraphy.**—In cable telegraphy, a mirror galvanometer employed as a receiver.
- Mirror Receiving-Instrument.**—(1) A receiving signalling instrument employed in submarine telegraphy, whose needle or suspension system is provided with a mirror. (2) A mirror galvanometer modified for use in telegraphing.
- Mirror Speaking - Instrument.**—A mirror receiving-instrument.
- Mixed Charge Test for Capacity.**—A test employed for determining the capacity of a submarine cable, in which an unknown capacity is charged to one potential, a known capacity is charged to an opposite potential, and the two charges are then mixed with the object of neutralization.
- Mixed Circuit.**—(1) In telephony, a circuit partly metallic and partly earth-circuited. (2) A term sometimes applied to the combination of a series and a multiple circuit.
- Mixed-Circuit Board.**—(1) A telephone switchboard arranged for the reception and inter-connection of metallic circuits and ground-return circuits. (2) A mixed-circuit switchboard.
- Mixed-Circuit Switchboard.**—A telephone switchboard connected with mixed circuits or circuits of which some are metallic and others are provided with ground return.
- Mixed Distribution.**—(1) A distribution

- of electric energy which combines both series and parallel distribution. (2) Series-parallel or parallel-series distribution.
- Mixing Key.**—The key employed in simultaneously charging a cable and a condenser for producing the mixed charge employed in the mixed-charge test for capacity.
- Mixture Photometer.**—A photometer combining the principles of the compensation and the polarization photometer.
- Moderate-Speed Generator.**—A generator designed to be run at a moderate speed, as distinguished from a slow-speed generator.
- Moderate-Speed Motor.**—A motor designed to work at a moderate speed, as distinguished from a slow-speed motor.
- Modulus of Elasticity.**—(1) The ratio of the simple stress required to produce a small elongation or compression in a rod of unit area of normal cross-section, to the proportionate change of length produced. (2) Young's modulus.
- Moist Electrode.**—A therapeutic electrode moistened with water or some other liquid.
- Moist Voltaic Cell.**—A form of the so-called dry voltaic cell.
- Moisture-Proof Insulation.**—(1) Water-proof insulation. (2) A type of insulation which is not strictly water-proof, but which is capable of being immersed for a short time without suffering serious loss of insulation.
- Molar Attraction.**—(1) Mass attraction, as distinguished from molecular attraction or cohesion. (2) Gravitation.
- Molar Vibration of Telephone Diaphragm.**—The mass vibration of a telephone diaphragm, as distinguished from molecular vibration.
- Molecular.**—Of or pertaining to the molecules.
- Molecular Accommodation.**—A rearrangement of the molecules of a paramagnetic substance resulting, by constant repetition, in a decrease in the hysteretic friction in cyclic magnetization.
- Molecular Agitation.**—Rapid mechanical vibration given to a mass of iron for the purpose of reducing its magnetic hysteresis.
- Molecular Attraction.**—(1) The mutual attraction existing between neighboring molecules. (2) Cohesion or adhesion.
- Molecular Bombardment.**—(1) The collisions which occur between neighboring molecules, and which are accentuated and accelerated by heat. (2) The forcible rectilinear projection from the negative electrode of the residual gaseous molecules in an exhausted vessel, on the heating of the same, or on the passage through it of an electric discharge.
- Molecular Chain.**—A polarized chain of molecules that is assumed by Gröthuss' hypothesis to exist in an electrolyte during its electrolytic decomposition, or in a voltaic cell on the closing of the circuit.
- Molecular Conductance.**—The conductance offered by a mass of an electrolyte equal to its molecular weight in grammes, when contained in an insulating vessel furnished with two opposite parallel conducting sides or faces, distant one centimetre apart.
- Molecular Conductivity of Electrolyte.**—(1) The conductance possessed by one gramme-molecule of an electrolyte when placed between electrodes one centimetre apart. (2) A term sometimes used for molecular conductance.
- Molecular Configuration.**—A term for the molecular groupings or the relative position of the molecules in a magnetizable substance.
- Molecular Currents.**—(1) A term sometimes employed for Amperian currents. (2) Atomic currents.
- Molecular Decomposition.**—Decomposition of a molecule.
- Molecular Dissociation.**—(1) Molecular decomposition. (2) The disruption of molecules into ions, or atoms.
- Molecular Encounter.**—A collision between two molecules of a gaseous substance that takes place during the to-and-fro movements they describe in accordance with the kinetic theory of gases.
- Molecular Heat.**—The number of calories of heat required to raise one gramme-molecule of a substance one degree Centigrade.
- Molecular Kinetics.**—The kinetics of the molecules.
- Molecular Magnetomotive Forces.**—(1) The magnetomotive forces inherently possessed by the molecules. (2) The aligned or structural-magnetomotive force as distinguished from the prime magnetomotive force.
- Molecular Magnetism.**—(1) The magnetism resulting from molecular magnetomotive forces. (2) The inherent magnetic flux in a molecule of a magnetic substance.
- Molecular Magnetization.**—The in-

herent magnetization possessed by the molecules.

Molecular Magnets.—The inherently magnetized molecules.

Molecular Oscillations.—To-and-fro movements or oscillations of the molecules.

Molecular Range.—The distance at which the molecules of matter continue to exert a sensible attraction on one another.

Molecular Repulsion.—The mutual repulsion existing between molecules arising from their kinetic energy.

Molecular Resistance.—(1) The resistance offered by a mass of an electrolyte equal to its molecular weight in grammes, when contained in an insulating vessel having two opposite parallel conducting faces distant one centimetre apart. (2) The resistance of one gramme-molecule of an electrolyte when brought between two electrodes one centimetre apart.

Molecular Rigidity.—The resistance offered by the molecules of a substance to rotation or displacement.

Molecular Shadows.—The comparatively dark spaces on those portions of the walls of a Crookes tube, which have been protected by molecular bombardment by suitably interposed screens.

Molecular Streams.—Rectilinearly directed streams of molecules, thrown off from the cathode of a high-vacuum tube, under the influence of heat or electric discharges.

Muscular Theory of Muscle and Nerve Currents.—A theory which regards every muscle or nerve fibre as formed of a number of series-connected electromotive molecules surrounded by a neutral conducting fluid.

Molecular Transfer of Heat.—The transfer of heat by means of molecular vibrations.

Molecular Vibration of Telephone Diaphragm.—The molecular vibration of a telephone diaphragm under the influence of the changes in the magnetization of the telephone magnet, as distinguished from its molar vibration.

Monochromatic Photometry.—(1) The photometry of monochromatic lights. (2) Photometry in which the spectra or the compositions of the lights to be compared are similar.

Molecular Voltaic-Couple.—A voltaic couple formed of the atoms or radicals of a molecule.

Molecular Vortices.—The vortices in the ether which, according to a particular

theory, are assumed to constitute the molecules, atoms or ultimate particles of matter.

Molecule.—(1) The smallest quantity of a compound substance that can exist as such. (2) A group of atoms whose chemical bonds or affinities are completely satisfied.

Molten-Platinum Lamp.—The violle or molten platinum standard.

Molten-Platinum Standard of Light.—(1) The violle. (2) The practical standard of white light adopted at the Electrical Congress of Paris, in 1884, and defined as the total quantity of light emitted by a square centimetre of molten platinum at the temperature of its solidification.

Moment.—(1) Torque. (2) The product of any quantity, directed with respect to an axis, and the perpendicular distance of its direction from that axis.

Moment of a Couple.—(1) The torque or effective power of a couple. (2) The intensity of one of the forces in a couple, multiplied by the perpendicular distance between the direction of the forces.

Moment of a Magnet.—The polar length of a magnet multiplied by the intensity of magnetism of one of its poles.

Momentary Current.—(1) A current that continues flowing but for a short time. (2) A current of brief duration.

Momentum.—(1) The product of the mass of a moving body by its velocity. (2) Quantity of motion in a system.

Monad Atom.—An atom whose valency or atomicity is one.

Monivalent.—(1) Possessing a valency or atomicity of one. (2) Univalent, or monovalent.

Monochord.—A sonometer.

Monocular.—An eye-piece or glass, provided for a single eye.

Monophotal Arc-Light Regulator.—A term sometimes employed for an electric arc-lamp in which the whole current passes through the arc-regulating mechanism, and which is usually operated singly in circuit with a dynamo.

Monocycler.—A monocyclic generator.

Monocyclic.—Of or pertaining to a monocycler, or to a monocyclic system.

Monocyclic Alternator.—A monocyclic generator.

Monocyclic Armature.—The armature of a monocyclic generator, provided with two sets of windings, one of which constitutes the main winding and corresponds to that of an ordinary uniphase, while

the second is of smaller cross-section and fewer turns, and is connected to the centre of the main winding in diphas relation to it.

Monocyclic Circuit.—The circuit of a monocyclic generator.

Monocyclic Generator.—A form of polyphase generator provided with a monocyclic armature.

Monocyclic Motor.—A form of induction motor suitable for use on monocyclic circuits.

Monocyclic System.—(1) A system of alternating-current distribution suitable for electric lighting with the additional capability of operating triphase induction motors. (2) A system for the distribution of alternating currents employing three wires, between two of which an ordinary uniphase pressure is maintained, while between either of them and the third, there is a diphased pressure.

Monogenic Charge.—A name proposed for such a distribution of an electric charge in which the sign of the surface density is everywhere the same.

Monophase Generator.—An alternator producing uniphase or monophase currents.

Monophase Motor.—A uniphase motor.

Mooring Chain.—A chain employed for the mooring of a cable buoy.

Mopped.—Subjected to the action of a polishing mop.

Morley Effect.—A decrease in the value of the hysteresis in the iron of a dynamo armature at full load.

Morse Alphabet.—The Morse telegraphic alphabet.

Morse Code.—The Morse telegraphic alphabet.

Morse Embosser.—A Morse register.

Morse Ink-Writer.—The name sometimes given to a Morse inker.

Morse Inker.—A form of telegraphic ink-writer printing signals in the Morse code.

Morse Push.—A term sometimes employed for a double-contact push.

Morse Recorder.—An apparatus for automatically recording the dots and dashes of the Morse telegraphic dispatch, on a fillet of paper drawn under an indenting or marking point on a striking lever connected with the armature of an electromagnet, as distinguished from a Morse inker.

Morse Register.—A Morse recorder.

Morse System of Telegraphy.—A sys-

tem of telegraphy in which makes and breaks, occurring at intervals corresponding to the dots and dashes of the Morse alphabet, are received by an electromagnetic sounder, or other receiver.

Morse Tapper.—A form of telegraphic key provided with two contacts, one in front, and another on the back, so arranged that the depression of the key makes one contact and breaks the other.

Morse Writer.—A form of telegraphic Morse ink-writer.

Morse Telegraphic-Alphabet.—Various groupings of dots and dashes or deflections of a needle to the right and left, employed for representing the letters of the alphabet or other signs.

Morse Telegraphic-Sounder.—An electro-magnet, the movements of whose armature lever produce the audible sounds corresponding to the dots and dashes of the Morse code.

Motional Electric Force.—The electric force induced by the motion of magnetic flux, or of the medium supporting the flux.

Motional Magnetic Flux.—Magnetic flux produced by the motion of an electrostatic charge, or of electrostatic flux.

Motorneer.—A word proposed for motor-man. (Not in general use.)

Motor Armature.—The armature of an electric motor.

Motor Car, Electric.—An electrically propelled car.

Motor Circuit.—A circuit containing an electric motor.

Motor-Controlling Rheostat.—A rheostat connected with a motor, and employed for starting the motor or for regulating its speed.

Motor Cut-Out.—A cut-out provided in the circuit of a motor for the purpose of throwing it out of circuit.

Motor-Dynamo.—(1) An electrically driven motor, rigidly connected to the armature of a dynamo, and employed for transforming or changing the pressure of a direct-current circuit. (2) The combination, in a continuous-current generator of a motor and a dynamo, in separate structures, mechanically connected to form a single machine or structure.

Motor-Electromotive Force.—A term proposed for the counter-electromotive force of a motor.

Motor, Electric.—A device for transforming electric power into mechanical power.

Motor-Generator.—(1) A motor coupled

- to a generator. (2) A motor-dynamo. (3) A form of secondary generator.
- Motorman.**—The man who operates a trolley car.
- Motor-Meter.**—(1) An electric meter whose operations depend on the movements of an electric motor. (2) A meter connected with the supply circuit of an electric motor.
- Motor Slip.**—The deviation of an induction motor from synchronous speed, or the proportional loss of synchronous speed due to load and losses of energy.
- Motor Standards.**—The supports for the bearing of an electric motor.
- Motor Starter.**—A term proposed for a motor starting-rheostat.
- Motor Starting-Box.**—A box containing a starting rheostat or controller.
- Motor Starting-Rheostat.**—An adjustable rheostat provided for preventing an abnormal rush of current through a shunt-wound motor, on the starting of the same.
- Motor Suspension.**—The suspension provided for the electric motors on a street-car truck.
- Motor Switch.**—A switch provided for the control of a motor.
- Motor Telegraph Printing System.** A printing telegraph system in which two motors, one at the transmitting, and one at the receiving end of the line, are maintained in synchronous rotation.
- Motor Torque.**—The rotary effort developed by an electric motor.
- Motor-Transformer.**—(1) A transformer or secondary generator operated by a motor. (2) A motor-generator, dynamo-tor, or rotary-transformer. (3) A dynamo-electric machine having two armature windings, one to receive current as a motor, and the other to deliver current to a secondary circuit as a generator.
- Motor Truck.**—The truck of an electric car provided with supports for the suspension of an electric motor or motors.
- Motoring at Brushes.**—A term proposed for flashing at the brushes of a motor.
- Moulded Carbons.**—Artificial carbons made by moulding mixtures of carbonaceous substances under pressure.
- Moulded Filaments.**—The formation of an incandescent filament by moulding a suitable carbonaceous paste by hydraulic pressure.
- Moulded Mica.**—An insulating substance consisting of finely divided mica, made into a paste with some fused insulating material, and moulded into the desired shape before cooling.
- Moulding Wiring.**—Electric conductors or wires that are held in place on the walls or ceiling of a room by means of suitably-shaped mouldings.
- Mouldings, Electric.**—Mouldings of dried non-conducting wood, provided with longitudinal grooves for the reception and support of insulated wires.
- Mounted Filament.**—The filament of an incandescent lamp placed on its support, ready for introduction into the lamp chamber.
- Mounting of Filament.**—Providing the filament and leading-in wires of an incandescent lamp with a suitable glass support ready for introduction into the chamber of an incandescent lamp, and its hermetical sealing therein.
- Mouse-Mill Dynamo.**—A form of dynamo-electric machine employed to drive a replenisher or influence machine.
- Mouse-Mill Machine.**—A form of induction machine employed as a replenisher or high-tension source.
- Mouth-Pieces.**—Circular openings into air chambers, placed over the diaphragms of telephones, phonographs, gramophones, or graphophones, to permit the ready application of the mouth in speaking, so as to set the diaphragm in vibration.
- Movable.**—Capable of being moved.
- Movable Secondary.**—The secondary of an induction coil, which, instead of being fixed, as in most coils, is movable.
- Multi - Cellular Electrostatic Voltmeter.**—An electrostatic voltmeter in which a series of fixed and movable plates are employed, instead of the single pair of plates of the quadrant electrometer.
- Multi-Circuit Arc-Dynamo.**—A dynamo whose armature is provided with several circuits designed to avoid too high an electromotive force on any single circuit.
- Multi-Circuit Arc-Light Generator.**—(1) An arc-light generator designed to supply, several series-connected arc-circuits, as distinguished from a generator designed to supply a single circuit. (2) A multi-circuit arc dynamo.
- Multi-Coil Alternating-Current Armature-Winding.**—An alternator armature-winding containing on its surface more than one coil or group of conductors per pole of the field frame, as distinguished from a uni-coil winding.
- Multi-Conductor Cable.**—A cable provided with a plurality of conducting circuits.

- Multi-Duct Conduit.**—A conduit containing a plurality of ducts.
- Multi-Periodic Current.**—(1) A current composed of a number of associated component currents of different frequencies. (2) A complex-harmonic current.
- Multiphase.**—Containing more than a single phase.
- Multiphase Alternating-Currents.**—A number of separate alternating currents which differ in phase by a fixed amount.
- Multiphase Alternator.**—An alternator capable of producing multiphase currents.
- Multiphase Apparatus.**—A general term for multiphase alternators, motors, or other receptive apparatus, suitable for use on multiphase circuits.
- Multiphase Circuits.**—The circuits employed in a system of multiphase distribution.
- Multiphase Dynamo.**—A multiphase alternator.
- Multiphase Generator.**—A multiphase alternator.
- Multiphase Induction-Motor.**—An induction motor suitable for use in connection with multiphase currents, and operated by rotating magnetic fields.
- Multiphase Synchronous-Motor.**—A synchronous alternating-current motor supplied with multiphase currents as distinguished from an asynchronous or induction multiphase motor.
- Multiphase System.**—A system for the distribution of energy by multiphase currents.
- Multiphaser.**—A multiphase alternator.
- Multiple-Arc Circuit.**—A term often used for multiple circuit.
- Multiple-Arc-Connected Electro-Receptive Devices.**—Electro-receptive devices connected with the driving circuit in multiple arc.
- Multiple-Arc-Connected Sources.**—A battery of multiple-connected sources.
- Multiple-Arc-Connected Translating Devices.**—Multiple-arc connected electro-receptive devices.
- Multiple-Arc Resistance Box.**—A resistance box whose resistances are capable of being inter-connected in multiple arc.
- Multiple Armature-Windings.**—(1) A term sometimes used for multiple-circuit armature-windings. (2) A term sometimes used for multiple-wound armature windings.
- Multiple Cable.**—A cable containing more than a single conducting wire or circuit.
- Multiple Cable-Core.**—A cable containing more than a single conducting wire or core.
- Multiple Call-Box.**—A call-box capable of automatically transmitting a number of different calls.
- Multiple Circuit.**—A circuit in which a number of separate sources or separate receptive devices, or both, have all their positive poles connected to a single positive lead or conductor, and all their negative poles connected to a single negative lead or conductor.
- Multiple - Circuit Multiple - Wound Armature.**—An armature providing a plurality of circuits between the brushes, and also a plurality of independent windings connected to symmetrically interspersed independent commutator bars.
- Multiple Circuit Winding of Armature.**—Such a winding as provides a multiplicity of circuits in parallel through an armature.
- Multiple Conduit.**—A conduit provided with a number of separate ducts.
- Multiple - Connected.**—Connected in multiple-arc.
- Multiple-Connected Battery.**—A battery whose separate cells are connected in multiple-arc.
- Multiple-Connected Electro - Receptive Devices.**—Multiple-arc-connected translating devices.
- Multiple-Arc-Connected Sources.**—A number of separate sources connected in multiple-arc, so as to act as a single source.
- Multiple Connection.**—Connection in parallel or in multiple-arc.
- Multiple-Contact Carbon Telephone Transmitter.**—(1) A telephone transmitter provided with a number of separate contacts. (2) A dust telephone transmitter.
- Multiple Converter.**—A multiple transformer.
- Multiple Electric Gas-Lighting.**—A system of electric gas-lighting in which a number of gas jets are ignited by high electromotive force discharges obtained from a Ruhmkorff coil or static induction machine.
- Multiple Electrode Telephone.**—A telephone transmitter possessing a plurality of active contacts.
- Multiple Electrolysis.**—Electrolysis pro-

- ducing or accompanied by secondary chemical reactions.
- Multiple-Harmonic Telegraph.**—A general term embracing the apparatus employed in multiple-harmonic telegraphy.
- Multiple-Harmonic Telegraphy.**—A system for the simultaneous transmission of a number of separate and distinct musical notes over a single wire, which separate notes are utilized for the simultaneous transmission of an equal number of independent telegraphic messages.
- Multiple Jacks.**—The reduplicating jacks of a multiple telephone switchboard.
- Multiple Lightning Flash.**—Several lightning flashes apparently coming from the same cloud.
- Multiple-Pair Brush-Rocker.**—A term sometimes used for multiple-pair brush-yoke.
- Multiple-Pair Brush-Yoke.**—A device for holding a number of pairs of brushes on the commutator, so that they can all be simultaneously moved or rotated thereon.
- Multiple-Parallel Circuit.**—A term sometimes employed for a multiple of parallel circuits.
- Multiple Quadruplex.**—A system of repeating from more than one quadruplex circuit to a branch office, or repeating from one quadruplex circuit to another.
- Multiple Resonance.**—The partial resonance of a primary conductor devoid of a definite period of oscillation, and, therefore, capable of performing all possible oscillations lying within wide limits.
- Multiple Rheostat.**—A form of rheostat whose resistances are capable of being thrown into a circuit in multiple, so that the carrying capacity increases as the resistance is decreased.
- Multiple Running.**—The operation of generators in parallel.
- Multiple-Series.**—A multiple connection of series groups.
- Multiple-Series Circuit.**—A circuit in which a number of separate sources, or receptive devices, or both, are connected in a number of separate groups in series, and these separate groups subsequently connected in multiple.
- Multiple-Series Condenser.**—(1) An arrangement of groups of condensers in series, which groups are connected in multiple. (2) A condenser divided into parts capable of being connected either in multiple, or in series, or in both.
- Multiple-Series-Connected Receptive or Translating Devices.**—A number of receptive or translating devices connected in multiple-series.
- Multiple-Series-Connected Sources.**—A number of separate electric sources so connected in multiple-series, as to be capable of acting as a single source.
- Multiple-Series Connection.**—Connection in multiple-series.
- Multiple Switch.**—A switch provided with a number of separate contact plates for controlling a plurality of circuits.
- Multiple Switchboard.**—A switchboard to which the numerous circuits employed in systems of telegraphy, telephony, annunciators, or electric light and power circuits, are connected.
- Multiple-Tablet Switchboard.**—A switchboard provided with a number of separate tablets or panels.
- Multiple Telegraphic Repeater.**—A telegraphic repeater which repeats from one circuit to two or more Morse circuits.
- Multiple Telegraphy.**—A system for the simultaneous telegraphic transmission over the same wire of more than a single message in the same direction.
- Multiple Telephone Receiver.**—(1) A telephone receiver in a multiple telephone circuit. (2) A composite telephone receiver.
- Multiple Telephone Switchboard.**—A switchboard consisting in reality of a number of separate switchboards, each provided with separate operators and bearing transmitter keys, switches and generators, employed when the number of subscribers connected with the switchboard exceed a number such as can be handled by a single switchboard.
- Multiple Telephony.**—The simultaneous transmission over the same wire of a number of separate telephonic despatches, in the same direction.
- Multiple Transformer.**—(1) Any form of transformer the coils or circuits of which are connected in multiple. (2) The ordinary alternating-current transformer connected across a supply circuit, as distinguished from a series transformer.
- Multiple Transmission.**—The simultaneous sending of two or more messages over a single conductor in the same direction.
- Multiple Unit System of Railway Traction.**—A system of electric railways in which each traction unit is provided with its own independent motors, in such a manner that all the units may be operated collectively from a single point.

- Multiple Valued Function.**—A function which has more than one value for a single value of its variable.
- Multiple Wheel Printing Telegraph.**
A printing telegraph instrument provided with a plurality of printing wheels.
- Multiple Windings.**—Independent windings symmetrically disposed upon the same armature, insulated from each other, but brought to different segments of the commutator.
- Multiple-Wound Multiple-Circuit Armature.**—A multipolar armature having a plurality of windings, and each winding having a plurality of circuits between the brushes.
- Multiple-Wound Two-Circuit Armature-Windings.**—A multipolar armature having a plurality of windings, each winding having two circuits between the brushes.
- Multiple Working of Dynamo-Electric Machines.**—A term sometimes used for parallel working of dynamo electric machines.
- Multiples.**—The jacks in the various sections of a multiple-telephone switchboard, which are connected to the same line or subscriber.
- Multiplex Telegraph.**—A general term embracing the apparatus employed in multiplex telegraphy.
- Multiplex Telegraphy.**—(1) A system of telegraphy for the simultaneous transmission in opposite directions of more than two separate messages over a single wire from each end. (2) A term sometimes used for multiple telephony or simultaneous transmission of more than one message in the same direction over a single wire.
- Multiplex Telephony.**—A system of telephony for the simultaneous transmission in opposite directions of more than two separate messages over a single wire from each end.
- Multiplex Working.**—Multiplex transmission.
- Multiplicator.**—A term sometimes used for multiplier.
- Multiply.**—In a multiple telephone switchboard to reduplicate or to repeat at each section of the switchboard.
- Multiply Re-Entrant Armature-Winding.**—An armature-winding provided with a plurality of separate conducting paths or windings, each of which is independently re-entrant.
- Multiplying Power of Shunt.**—A quantity by which the current flowing through a galvanometer or other device provided with a shunt, must be multiplied, in order to give the total current.
- Multi-Point Secondary.**—A secondary coil arranged so that it can be readily tapped at different points.
- Multipolar Armature.**—An armature suitable for use in a multipolar field.
- Multipolar - Drum Armature - Windings.**—Windings of a drum armature suitable for a multipolar field; *i. e.* producing more than two poles on the armature surface.
- Multipolar Dynamo.**—A dynamo provided with a multipolar field.
- Multipolar Electric Bath.**—An electro-therapeutic bath in which more than two electrodes are employed.
- Multipolar Field.**—A field produced by more than two separate magnet poles.
- Multipolar Generator.**—A multipolar dynamo.
- Multipolar Motor.**—A motor whose field-magnets contain more than two separate magnet poles.
- Multipolar Railway - Generator.**—A generator having a multipolar field, employed for furnishing current to trolley cars.
- Multipolar-Ring Armature-Winding.**
The winding of a ring armature adapted to a multipolar field.
- Multipolar Winding.**—A winding suitable for use in multipolar generators or motors.
- Multi-Slot Armature - Winding.**—A multi-coil armature winding.
- Multi-Slot Alternating-Current Iron-Clad-Armature.**—An iron-clad armature having more than one slot per field pole and furnishing alternating currents.
- Municipal Series Circuit.**—A series circuit employed for the distribution of incandescent lights and suitable for lighting streets.
- Municipal System of Incandescent Electric Lighting.**—A system for the distribution of incandescent electric lights, in which the separate lamps are connected to the circuit in series, each lamp being provided with a film or other automatic cut-out.
- Muscle Currents.**—In electro-therapeutics the electric currents flowing through a muscle during its stimulation or activity.
- Muscular Pile.**—Matteucci's muscular pile.

Mushroom Anchor.—An anchor resembling a mushroom in form and used for mooring buoys in submarine cable-work, so as to resist dragging along the sea-bottom and yet avoid becoming tightly engaged in rocks.

Mushroom Deposit on Negative Carbon.—A flat deposit of graphitic carbon of a mushroom shape, that forms on the negative carbon of an enclosed arc-lamp.

Musket, Electric.—A gun whose charge is ignited by a platinum wire rendered incandescent by the action of a battery placed in the stock of the gun.

Mutual Flux of Transformer.—The magnetic flux which passes through both coils in a transformer as distinguished from magnetic flux which may traverse one coil, when excited to the exclusion of the other.

Mutual Inductance.—(1) The coefficient of mutual induction between two conductors. (2) The flux linkages in one circuit due to unit current in the other.

Mutual Induction.—(1) Induction produced on each other by two neighboring circuits through the mutual inter-connection of their magnetic fluxes. (2) Induction produced in neighboring charged conductors by the inter-connection of their electrostatic fluxes.

Myograph.—An instrument for measuring nervous sensibility.

Myopia.—Near-sightedness.

Myopic.—Of or pertaining to near-sightedness.

Myria.—A prefix for ten thousand times.

N

N.—A symbol for the whole number of lines of magnetic flux or induction in any magnetic circuit.

N.—In submarine telegraphy, a code signal at the end of a message to indicate that there are no more messages to follow.

N.—A contraction for north-seeking magnetic pole.

n.—(1) A symbol employed for frequency. (2) A contraction for a number.

N. H. P.—A contraction for nominal horsepower.

Name Plate.—A plate fastened to a dynamo-electric machine and bearing the name of the maker and other particulars such as the speed, power, weight, pressure, and current of the machine.

Narrow-Gauge Street-Railway Motor.—A street-railway car motor of less breadth than usual, suitable for use on narrow-gauge tracks.

Nasal Electrode.—An electrode suitable for introduction into the nostril for its therapeutic treatment.

Nascent State.—A term used in chemistry to express the state or condition of an elementary atom or radical when just liberated from chemical combination, when it possesses chemical affinities or attractions more energetic than afterwards.

Natural Current from Fault in Cable. The feeble current originating from the voltaic couple formed at a break or fault in a cable.

Natural Currents.—A term sometimes applied to earth currents.

Natural-Draught Transformer.—(1) An alternating-current transformer in which an air-space is left between the primary and secondary coils, through which a convection current of air passes on the heating of the coils. (2) A transformer cooled by radiation and convection, as distinguished from an air-transformer.

Natural Electret.—A body whose molecules are inherently electrized, as distinguished from a body whose molecules become electrized by induction.

Natural Law.—(1) A law of nature. (2) An observed co-relation of phenomena such that when one phenomenon or group of phenomena occurs in a certain definite way, another phenomenon or group of phenomena invariably follows.

Natural Magnet.—The name sometimes given to a lodestone.

Natural Period.—(1) The time in which a cyclic phenomenon naturally completes itself. (2) The time of complete free oscillation of a vibrating substance or condition, when not subjected to external restraint.

Natural Resultant Fault.—In any circuit, a fault which is the electrical equivalent in position and magnitude of all the actual small faults or leakages which may be present in that circuit.

Natural Unit of Electricity.—(1) A term sometimes used in place of an atomic

charge of electricity. (2) The quantity of electricity carried by a single monad atom of any elementary substance.

Natural Unit of Quantity of Electricity.—The quantity of electricity possessed as a charge by any elementary monad atom.

Naut.—A nautical mile.

Nautical Mile.—(1) A knot or naut, or a distance of 6,087 feet; or nearly 1.15 statute miles. (2) The $\frac{1}{371000}$ th of the earth's equatorial circumference, or $\frac{1}{30}$ th of a degree of longitude at the equator.

Nautical Telegraphy.—Telegraphy conducted at sea or over the sea, either between different vessels or on board a single vessel.

Near-Sightedness.—(1) Inability to see objects distinctly unless they are comparatively near the eye. (2) Myopia.

Nebula.—A misty appearance in the heavens often resolved by a telescope into clusters of innumerable stars.

Needle.—A word frequently used for a magnetic needle.

Needle Annunciator.—An annunciator whose indications are obtained by the movements of a needle, instead of by the fall of a drop.

Needle Electrode.—A needle-shaped therapeutic-electrode employed for electrolytic treatment.

Needle Instrument.—A single-needle instrument.

Needle of Oscillation.—A small magnetic needle employed for measuring the intensity of a magnetic field by the number of oscillations it makes in a given time when disturbed from its position of rest in such field.

Needle System of Telegraphy.—A system of telegraphy in which the letters of the alphabet and numerals are indicated by the to-and-fro movements of a magnetic needle.

Needle Telegraph.—A general term embracing the apparatus employed in needle telegraphy.

Needle Telegraphy.—The needle system of telegraphy.

Negative Brush of Dynamo.—The brush connected with the negative terminal of a dynamo.

Negative Brush of Motor.—The brush connected with the negative terminal of the driving source.

Negative Bus-Bars.—The negative omnibus bars.

Negative Charge.—(1) According to the double-fluid hypothesis, a charge of negative electricity. (2) According to the single-fluid hypothesis, any deficit of an assumed electric fluid. (3) An electric charge of the same character as that produced on silk when rubbed by glass.

Negative Conductor.—The conductor connected to the negative terminal of an electric source.

Negative Currents.—In telegraphy, a term applied to the currents sent over a line from the negative pole of the battery.

Negative Direction of Electrical Convection of Heat.—A direction in which heat is transmitted by electric convection, through an unequally heated conductor opposite to that of an electric current.

Negative Direction of Simple-Harmonic Motion.—Simple-harmonic motion in which the generating circle is moved over in the negative direction.

Negative Electricity.—(1) One of the phases of electric excitement. (2) The kind of electric charge produced on resin when rubbed with cotton.

Negative Electromotive Force.—Such an E. M. F. as is produced at the free pole of a battery or other source whose positive pole is grounded.

Negative Electrification.—(1) The charging of a body with negative electricity. (2) A negative charge.

Negative Electrode.—The electrode connected with the negative terminal of a source.

Negative Element of Electrolyte.—(1) The element which in electrolysis appears at the positive electrode. (2) The cathion.

Negative Element of Voltaic Cell.—(1) That element of a voltaic couple which is not acted on by the electrolyte. (2) The element which forms the positive pole of the cell above the surface of the electrolyte.

Negative Feeders.—The feeders connecting the negative mains with the negative poles of the generators.

Negative Fluid.—(1) A specific fluid which was formerly believed by the advocates of the double-fluid electric hypothesis to be the cause of negative excitement. (2) A deficit of an assumed single electric fluid.

Negative Inductance.—A capacitance.

Negative Lightning.—A name given to a variety of lightning discharge whose existence is apparent in some photo-

graphic negatives of lightning flashes, as black branches coming out from the main-lightning stem.

Negative Omnibus-Bar.—The bus-bar connected to the negative terminals of the generators.

Negative Phase of Electrotonus.—A decrease in the electromotive force of a nerve, produced by sending an electric current through the nerve in the opposite direction to the nerve current.

Negative Plate of Storage Cell.—(1) That plate of a storage cell which is converted into or partly covered with a coating of spongy lead by the action of the current. (2) That plate of a storage cell which is connected with the negative terminal of the charging source, and which is, therefore, the negative pole of the cell on discharging.

Negative Plate of Voltaic Cell.—(1) The electro-negative element of a voltaic couple. (2) That element of a voltaic couple which is negative in the electrolyte of the cell. (3) That portion of the plate of a voltaic cell above the liquid, which becomes the positive pole of the cell.

Negative Pole of Receptive Device.—That pole of a receptive device which is connected to the negative pole of a source.

Negative Pole of Source.—That pole of an electric source through which the current is assumed to enter, or flow back into the source, after having passed through the circuit connected to the source.

Negative Potential.—(1) A potential such as determines a tendency of electricity to flow towards it from the earth or from any point of positive potential. (2) Generally, the lower potential or lower level. (3) That property of a point in space by virtue of which electric work is done by the movement of a small positive charge to that point from an infinite distance.

Negative Rays.—The molecular streams given off at the negative electrode or cathode of an induction tube, on the passage of electric discharges through the tube.

Negative Resistance.—A property of a circuit or conductor containing an E. M. F., whereby a current flowing through the conductor rises in pressure instead of falling.

Negative Rotation.—Right-handed or clockwise rotation, as viewed from in front of the clock.

Negative Side of Circuit.—(1) The side of a circuit opposite to the positive sides.

(2) That side of a circuit bent in the form of a circle, from which, if an observer stood with his head in the negative region, he would see the current pass around him clockwise, or right-handedly. (3) The side of a circuit connected with the negative pole of the source.

Negative Spark.—The spark produced by the discharge of a negatively charged conductor.

Negative Terminal.—(1) The terminal of a voltaic cell connected with the positive plate or element. (2) The terminal of a source connected with the negative pole. (3) The terminal of a translating device connected with the negative pole of the source.

Negative Wire.—(1) A wire charged, or intended to be charged, negatively. (2) A wire connected with the negative pole of a source. (3) A wire of negative potential.

Negatively Excited.—Endowed with a negative charge.

Net Efficiency.—The final or ultimate efficiency of a series of machines or translating devices, through which energy, or any other quantity, has to successively pass, as distinguished from the separate efficiency of each machine or device.

Netted Globe.—A globe surrounding an arc-lamp and provided with an external netting.

Netting Wire.—A wire net-work-shield inclosing the globe of an arc-lamp, both to protect it from mechanical injury and to prevent glass from falling in case of fracture.

Network of Conductors.—A term applied to a number of interconnected conductors which may resemble a net in appearance.

Network of Currents.—A term sometimes applied to a number of shunts or derived circuits, or to the currents which flow in a network of conductors.

Neutral Armature.—A non-polarized armature.

Neutral Ampere-Meter.—An ampere-meter connected with the neutral bus-bar in a three-wire system of distribution.

Neutral Conductor.—The neutral wire in a three-wire system.

Neutral Feeder.—In a three-wire system, a feeder connected with the neutral bus-bar.

Neutral-Line of Magnet.—The equator of a magnet.

Neutral-Line of Commutator Cylinder.—A line on the commutator cylinder of a dynamo connecting the neutral points or points of zero potential.

Neutral-Line of Dynamo Armature.—(1) A line passing through the armature, symmetrically disposed as regards its entering and emerging flux. (2) A line of zero polarity.

Neutral Omnibus-Bar, or Bus-Bar.—In a three-wire system of distribution, the bus-bar connected with the neutral dynamo terminals, or the terminals uniting the positive and negative dynamos.

Neutral Point.—A term sometimes employed in electro-therapeutics for indifferent point.

Neutral Points of Magnet.—(1) Points approximately midway between the poles of a magnet. (2) Points of zero polarity.

Neutral Points of Dynamo-Electric Machine.—(1) Two points situated on the commutator cylinder at opposite ends of its diameter at which the collecting brushes must rest in order to obtain sparkless commutation. (2) Points of zero potential on a commutator.

Neutral Points of Thermo-Electric Diagram.—(1) The points on a thermo-electric diagram where the lines representing the thermo-electric powers of any two metals cross each other. (2) A mean temperature for any two metals in a thermo-electric series, at which, if their two junctions are slightly over or slightly under the mean temperature, the one as much above as the other is below, no effective electromotive force is developed.

Neutral Relay-Armature.—(1) A relay armature consisting of a piece of soft iron which closes a local circuit whenever its electro-magnet receives an impulse over the main line. (2) A normally unmagnetized relay armature.

Neutral Section of Magnet.—A section passing through the neutral line or equator of a magnet.

Neutral Salt.—A salt possessing neither acid nor basic properties.

Neutral Solution.—A solution of neutral salt.

Neutral Wire.—(1) In a three-wire system of electric distribution the wire connected to the neutral dynamo-terminal. (2) The balance wire of a three-wire system.

Neutral-Wire Ampere-Meter.—An am-

pere meter placed in the circuit of a neutral wire, in a three-wire system, for the purpose of showing the excess of current passing over one side of the system as compared with the other side, when a balance between the two is no longer maintained.

Neutral Zone of Charged Insulated Conductor.—That portion of an insulated conductor, charged by electrostatic induction, which lies approximately midway between its positive and negative end.

Neutral Zone of Magnet.—A term sometimes employed for equator of magnet.

Neutralization.—The act or quality of rendering neutral, as in the discharge of an electrified body.

New Ohm.—A term sometimes used for the international ohm.

Nib on Carbon Electrode.—A term sometimes employed for the graphitic deposit on one side of the negative carbon, when the arc has been maintained between the sides of two parallel carbon electrodes.

Nickel Bath.—An electrolytic bath containing a readily electrolyzable salt of nickel, a plate of nickel acting as the anode of the battery, and placed in a liquid near the object to be coated, which forms the cathode.

Nickel Facing of Electro-Type.—A thin electro-plating of nickel deposited on the surface of an electro-type for the purpose of hardening it.

Nickel Plating.—Electro-plating with nickel.

Niello-Work.—An enamelling process in which a pattern is traced upon a bright silver surface with a silver sulphide, or with mixtures of lead, copper and silver sulphide, artificially prepared, and which is afterwards fixed, by heating to the fusion point.

Nigger.—A term sometimes employed for a fault in any electric apparatus or system.

Night-Bell.—In a hotel or telephone exchange, a bell switched into connection with a shunted circuit of an annunciator case, and intended, by its constant ringing, to call the attention of the night operator to the falling of a drop.

Night-Switch for Telephone.—A switch so arranged that, when turned to the on-position, any or all of the drops will, on falling, ring a bell, and thus call the attention of the operator.

Nipple of Negative Carbon.—A tiny

projection of graphitic carbon, deposited during the maintenance of the arc, on the surface of the negative carbon opposite the crater of the positive carbon.

No. 1 Side of Quadruplex System.—That side of the quadruplex system which is employed in operating the polar duplex system.

No. 2 Side of Quadruplex System.—That side of a quadruplex system which contains the increment key and neutral relay.

Nobili's Rings.—Metallo-chromes.

Nodal Point.—A point in a vibrating string or wire free from vibration.

Node.—A nodal point.

Nodes, Electric.—(1) Points in a circuit or conductor through which electric oscillations are passing, which possess a constant value of potential, while the potential at the internode alternates between two fixed limits. (2) Points in a conductor where the strength of the induced oscillatory current is equal to zero.

Nodular, Electro-Metallurgical Deposit.—A coherent electro-metallurgical deposit, of irregular outline, which occurs whenever the current density falls below its normal value.

Noise.—(1) Any discordant assemblage of musical tones. (2) Any sound of too short duration to permit its pitch to be readily distinguished.

Noisy Arc.—A voltaic arc whose maintenance is attended by frying, hissing or spluttering sounds.

Nominal Candle-Power.—A term sometimes applied to the candle-power of a luminous source taken in a favorable direction.

Non-Arcing Arrester.—A non-arcing lightning arrester.

Non-Arcing Fuse.—A fuse wire formed of non-arcing metal, which, therefore, blows without the formation of a voltaic arc.

Non-Arcing Metal.—An alloy formed of mixtures of a certain group of metals, which, under certain conditions, will not permit the maintenance of an alternating-current arc between them.

Non-Arcing-Metal Lightning-Arrester.—A lightning arrester employing electrodes of non-arcing metals.

Non-Arcing Metals.—Metals forming non-conducting oxides such that an alternating-current arc is interrupted between them under certain conditions.

Non-Automatic Repeater.—A manual repeater.

Non-Automatic Variable Resistance. A resistance, the value of which is regulated by hand.

Non-Conductor.—Any substance whose conductivity is low, or whose electric resistance is great.

Non-Coperiodic.—(1) Non-synchronous. (2) Devoid of coperiodicity. (3) Not isochronous. (4) Having a period differing from the period considered.

Non-Coperiodic Electromotive Forces, Currents and Fluxes.—Electromotive forces, currents, or fluxes that are of different periods or frequencies.

Non-Electrics.—A term formerly applied to substances like the metals or other good conductors, which appeared not to be capable of electrification by friction.

Non-Ferric.—Devoid of iron.

Non-Ferric Inductance.—(1) The inductance possessed by a circuit which does not contain, or is not magnetically associated with, iron. (2) The inductance of a coil with a non-magnetic core.

Non-Ferric Inductance-Coil.—An inductance coil devoid of iron.

Non-Ferric Magnetic Circuit.—(1) A magnetic circuit devoid of iron. (2) A magnetic circuit containing only air, wood, copper or other non-magnetic materials.

Non-Homogeneous Current-Distribution.—(1) A distribution of current passing through a conductor, in which there is an unequal density of current over any cross section of the conductor. (2) The skin effect.

Non-Illumined Electrode.—That electrode of a selenium cell which is protected from the direct action of light.

Non-Inductive Load.—(1) An inductionless load. (2) A load consisting of resistance.

Non-Interfering Fire Telegraph.—A system of fire-alarm telegraphy in which two calls, simultaneously delivered, are incapable of interfering with each other.

Non-Interfering Street Signal Box.—A street signal box connected with a central station for the delivery of an alarm, in such a manner that two signals given at the same time from two different boxes will not interfere with each other.

Non-Inductive Resistance.—A resistance devoid of self-induction.

Non-Isotropic Expansion.—A property possessed by some crystalline substance of unequal expansion along different axes.

Non-Luminous Radiation.—Radiation incapable of affecting the eye.

Non-Luminous Heat Radiation.—(1) Heat radiation devoid of frequencies capable of exciting or producing the sensation of light. (2) Heat radiation devoid of luminous frequencies.

Non-Magnetic Steel.—Certain alloys of iron, such as manganese steel, or nickel steel, that are practically devoid of the ability of being magnetized.

Non-Multiple Telephone Switchboard.—(1) A telephone switchboard which is either not so large as to have rendered reduplication necessary, or which operates upon a system in which reduplication is dispensed with. (2) A single telephone-switchboard.

Non-Oscillatory.—(1) Not characterized by oscillations. (2) Maintaining the same direction of motion throughout.

Non-Oscillatory Charge.—A charge obtained by means of non-oscillatory electromotive forces or currents.

Non-Oscillatory Charging.—Charging uniformly by currents which are always of the same direction, as opposed to charging with oscillations in which the currents alternate.

Non-Oscillatory Current.—(1) A current that is devoid of periodic oscillation. (2) A uniform current.

Non-Oscillatory Discharge.—A steady discharge, or one characterized by freedom from periodic oscillation.

Non-Oscillatory Intermittent - Current.—A current which is intermittent, but always in the same direction, as distinguished from an oscillatory current whose direction alternates.

Non-Overlapping Winding of Alternator.—A winding in which the coils are mechanically separate and do not overlap.

Non-Periodic Alternating-Current.—An alternating current whose intensity varies non-periodically.

Non-Periodically Varying - Current.—A continuous current whose strength is subject to non-periodical oscillations.

Non-Polar Transformer.—A term sometimes used for a closed iron-circuit transformer.

Non-Polarizable.—Incapable of polarization.

Non-Polarizable Electrodes.—Electrotherapeutic electrodes constructed so as to avoid the effects of polarization.

Non-Polarized Armature.—An arma-

ture of soft iron which is attracted towards the poles of an electro-magnet on the completion of the circuit, no matter in what direction the current passes through the coils.

Non-Reactive Circuit.—A circuit which possesses neither inductance nor capacity, and, therefore, has ohmic resistance only.

Non-Sinusoidal Currents.—Alternating currents that are not of the true sinusoidal type.

Non-Synchronous Motor.—(1) An asynchronous motor. (2) An alternating-current motor capable of starting at any load. (3) An induction motor. (4) An alternating-current motor which is not compelled to run in synchronism with its driving current.

Non-Uniform Magnetic Flux.—Magnetic flux whose density varies in different portions of the magnetic circuit.

Non-Vibrating Filament Lamp.—An incandescent lamp with an anchored filament.

Normal.—(1) Perpendicular to. (2) In accordance with rule. (3) Regular.

Normal Current.—The current strength at which a system or apparatus is designed to be operated.

Normal Earth-Current.—The usual earth current.

Normal Magnetic-Day.—A day during which the values of the earth's magnetic elements do not vary greatly from their mean value.

Normal Voltage.—The voltage at which a system or apparatus is designed to be operated.

Normal Voltaic-Arc.—A voltaic arc whose characteristic properties are those possessed by the ordinary arc.

North Magnetic Pole.—That pole of a magnetic needle which points approximately to the earth's geographical north.

North-Seeking Magnetic Pole.—(1) The north magnetic pole. (2) That pole of a magnet which turns towards and approximately points to the north geographical pole of the earth.

Northern Lights.—(1) Luminous sheets, columns, arches or pillars of pale, flashing light, generally of a reddish color, seen in the northern heavens. (2) The aurora borealis.

Nose Suspension of Motor.—The suspension of a motor in a car truck by a projecting hook or nose from above, as distinguished from a suspension by a bar and spring from beneath.

Null or Zero Method.—(1) Any method employed in electrical measurements in which the values are determined by balancing against them equal similar values, and ascertaining such equality not by the deflection of the needle, but by the absence of such deflection. (2) Any method of measurement in which the criterion is no indication on the instrument employed, as distinguished from a method

depending upon the amounts or quantitative values of such indications.

Null Point.—(1) Such a point on a micrometer circuit that when joined or connected with the secondary circuit of an induction coil, the sparks in the micrometer circuit are either very greatly decreased, or are entirely absent. (2) A nodal point.

O

O.—An abbreviation for ohm, the practical unit of resistance.

O. K.—A telegraphic signal of acquiescence meaning "all right," and said to be a perversion of the initial letters of the phrase "all correct."

Ω.—A contraction for megohm.

ω.—A contraction for ohm.

ω.—A symbol sometimes employed for angular velocity.

O. cm.—An abbreviation proposed for ohm-centimetre, a standard of resistivity or conductivity.

Oblique Induction.—In the air gap of a dynamo, magnetic induction which is deflected from the perpendicular to the polar surface by armature reaction.

Obscure Heat.—Non-luminous heat.

Observation Mine.—A variety of submarine mine that is fired from a distant point when an enemy's vessel is observed to be within its destructive area.

Obtuse Angle.—Any angle whose value is greater than 90°.

Ocluded-Gas Process.—A process for the removal of the residual atmosphere from a vacuum tube, or from the chamber of an incandescent electric lamp, consisting in heating the same to a high temperature while connected with the pumps, before sealing off.

Oclusion of Gas.—The absorption or condensation of a gas in the pores or on the surfaces of various substances.

Ocean Cable.—A submarine cable.

Octo-Polar Dynamo.—A multi-polar dynamo whose field has eight poles.

Octo-Polar Field.—A field produced by the flux of eight separate magnet poles.

Od.—The name given by Reichenbach to the assumed force which he claimed to be the cause of animal magnetism.

Odd Harmonics.—In a complex harmonically varying quantity, the harmonics

whose frequencies are odd multiples of the fundamental frequency.

Odorscope.—An apparatus in which the determination of an odor was attempted by the measurement of the effect its vapor or effluvia produced on a contact resistance.

Odylic.—Of or pertaining to the od force.

Odylic Rays.—Rays accompanying the od force, which, according to Reichenbach, were emitted from magnet poles, and various other bodies, and were capable of producing faint luminous sensations in people sufficiently sensitive to their influence.

Oersted.—(1) The name proposed for the C. G. S. unit of magnetic reluctance. (2) The reluctance offered to the passage of magnetic flux by a cubic centimetre of air when measured between parallel faces.

Off Position of Switch.—(1) That position of a switch in which it throws a device or a portion of a circuit off from the working circuit. (2) The break position of a switch.

Office Cable.—(1) A cable of insulated wires suitable for indoor office-work. (2) A cable leading to a telegraph office.

Office Loop.—(1) In telegraphy, a loop, or two wires running to an office. (2) In telegraphy, a loop or pair of wires running from a circuit in an office to some desk in the same office, as distinguished from a loop running to some distant point.

Offset.—A side connection, or lateral, taken from a conduit or cable for connection to a service.

Ohm.—(1) The practical unit of electric resistance. (2) Such a resistance as would limit the flow of electricity under an electromotive force of one volt, to a current of one ampere, or one-coulomb-per-second. (3) A value equal to 10⁹ or 1,000,000,000 absolute electro-magnetic units. (4) A value which is represented

- conventionally in C. G. S. units by a velocity of 10^9 or 1,000,000,000 centimetres per second.
- Ohmage.**—The value of an electric resistance expressed in ohms.
- Ohmic.**—(1) Of or pertaining to the ohm. (2) Having the nature of an electric resistance.
- Ohmic Drop.**—The drop in pressure due the ohmic resistance.
- Ohmic Resistance.**—(1) The true resistance of a conductor due to its dimensions and conductivity, as distinguished from the spurious resistance produced by counter-electromotive force. (2) A resistance such as would be measurable in ohms by the usual methods of continuous-current measurement.
- Ohm-Meter.**—A commercial galvanometer employed for practically measuring, by the deflections of a magnetic needle, the resistance of any part of a circuit to which it is connected, and through which a current flows.
- Ohm Mile.**—(1) A standard of conductivity of wires one mile in length and having a resistance of one ohm at a standard temperature. (2) The product of the weight of a mile of wire and its resistance in ohms at a given temperature. (3) Such a mass of a substance, at a standard temperature, as would enable a uniform wire of that substance, one mile in length, to offer a resistance of one ohm.
- Ohm's Law.**—The strength of a continuous electric current in any circuit is directly proportional to the electromotive force acting on that circuit, and inversely proportional to the resistance of the circuit.
- Oil-Cooled Transformer.**—A transformer that is cooled by means of oil.
- Oil Cup.**—A cup filled with lubricating oil, so supported that its oil is slowly fed to a shaft and bearing, or in general, to the rubbing parts of a machine.
- Oil Guard.**—(1) A guard of sheet metal supported so as to catch any drops of oil that may be thrown upon its surface, and thus protect any person or apparatus. (2) A guard placed over a direct-driven dynamo, to prevent oil from being thrown on it by the revolving engine.
- Oil-Insulated.**—Insulated by means of oil.
- Oil Insulator.**—A fluid insulator containing oil.
- Oil Insulator for Storage Battery.**—An oil insulator provided for the support of a storage battery.
- Oil Paper.**—An insulating material consisting of paper that has been soaked in an insulating oil.
- Oil Transformer.**—(1) A transformer immersed in oil in order to ensure and maintain high insulation. (2) An oil-insulated transformer.
- Okonite.**—A variety of insulating material.
- Olivette Box.**—A box containing an arc-lamp provided with an aperture closed by colored glass, and employed for the purpose of obtaining a uniform field of color over a large surface, such as a stage scene.
- Omnibus Bars.**—(1) Heavy bars of copper connected directly to the poles of a dynamo in a central station, and, therefore, receiving their entire current. (2) Main conductors common to two or more dynamos in an electrical generating plant.
- Omnibus Wires.**—A word sometimes used for bus-bars.
- On Position of Switch.**—(1) That position of a switch in which it throws a device, or portion of a circuit, on to a working circuit. (2) The make position of a switch.
- One-Coil Transformer.**—A word sometimes employed for auto-transformer.
- One-Fluid Voltaic Cell.**—A name sometimes given to a single-fluid voltaic cell.
- One-Layer Armature-Winding.**—(1) An armature winding consisting of but a single layer of wire. (2) A winding which, although it may consist of several layers, would be possible of application in a single layer, as distinguished from a two-layer armature which must be laid in two layers.
- One-Metal Cell.**—An identical electrode cell. (2) A cell in which both elements are composed of one metal.
- One-Way Door-Trigger.**—A door-trigger which operates on the opening of the door only.
- Opacity.**—Possessing the property of non-transparency to radiation.
- Open-Arc.**—A non-enclosed voltaic arc.
- Open-Box Conduit.**—A conduit consisting of an open box of wood placed in a trench and closed with a wooden cover, after the introduction of the cable.
- Open Car-Wheel.**—A form of car-wheel in which the space between the flange and the axle is provided with symmetrical perforations.
- Open Circuit.**—A broken circuit, or a circuit whose conducting continuity is broken.
- Open-Circuit Battery.**—A voltaic bat-

- tery which is normally on open circuit, and which is used continuously on closed circuit only for comparatively small portions of time.
- Open-Circuit Burglar-Alarm.**—A burglar alarm whose battery is normally on open circuit, and is brought into action on the closing of such circuit as a door, window, or other point.
- Open-Circuit Current of Transformer.**—A term sometimes employed for the leakage current of a transformer.
- Open-Circuit Electric Oscillations.**—Electric oscillations produced in open circuits by the presence of electric surgings in neighboring circuits.
- Open-Circuit Induction.**—The induction produced in an open circuit by means of electric surgings in neighboring circuits.
- Open-Circuit of Triphase Connections.**—The star-connection of triphase circuits.
- Open-Circuit Single-Current Signaling.**—A system of single-current signaling in which the sending batteries placed at each station are in circuit during signalling only.
- Open-Circuit Thermostat.**—A thermostat maintained normally on an open-circuit.
- Open-Circuit Transformer.**—(1) A transformer whose magnetic circuit is partly completed through air. (2) An aero-ferric-circuit transformer.
- Open-Circuit Voltaic Cell.**—A voltaic cell that cannot be kept on closed circuit with a comparatively small resistance, for any considerable time, without serious polarization.
- Open-Circuit Voltmeter.**—(1) A voltmeter in which the points of a circuit where the potential difference is to be measured, are connected with an open-circuit to give indications by means of the charges so produced. (2) An electrometer-voltmeter.
- Open-Circuited.**—Provided with an open or broken circuit.
- Open-Circuited Conductor.**—(1) A conductor not forming a closed circuit. (2) A conductor not closed on itself, and whose metallic continuity, therefore, is not complete, but through which an oscillatory discharge is capable of passing.
- Open - Circuited Discharge.**—A discharge taking place through a circuit whose metallic continuity is incomplete.
- Open-Circuited Oscillation.**—An electric oscillation or surging taking place in an open-circuited conductor.
- Open-Circuit Thermostat.**—A thermostat maintained normally on an open-circuit.
- Open - Circuited Transformer.**—An aero-ferric-circuit transformer.
- Open-Coil Armature.**—An armature, some of whose coils are on open-circuit during a portion of the rotation of the armature.
- Open-Coil Armature-Windings.**—The windings of an open-coil dynamo armature.
- Open - Coil Disc Dynamo - Electric Machine.**—(1) A disc-wound dynamo-electric machine whose armature coils are open-circuited during part of each revolution. (2) An open-coil dynamo-electric machine, the armature of which is disc shaped.
- Open - Coil Drum Dynamo - Electric Machine.**—An open-coil dynamo-electric machine, the armature of which is drum-wound.
- Open-Coil Dynamo.**—A dynamo provided with an open-coil armature.
- Open - Coil Ring Dynamo - Electric Machine.**—An open-coil dynamo-electric machine, the armature of which is ring-wound.
- Open - Iron - Circuit Converter.**—An open-iron-circuit transformer.
- Open-Iron-Circuit Transformer.**—An aero-ferric transformer.
- Open-Iron-Magnetic Circuit.**—An aero-ferric magnetic circuit.
- Open Magnetic Core.**—Any iron core which forms a portion of an aero-ferric circuit.
- Open Trolley-Car.**—A trolley-car open on the sides and ends.
- Open-Wire Symmetrical Twist.**—A system of stringing aerial telephone wires, so as to avoid cross talk, in which all the wires on a pole are helically twisted right-handedly along the line, one step being taken at each successive pole.
- Open Wiring.**—(1) Wiring that has been purposely left exposed to view. (2) Wiring supported on cleats or insulators as distinguished from channelled, panelled, or covered wiring.
- Open Work.**—Open wiring.
- Opening a Circuit.**—Breaking a circuit.
- Opening Shock.**—The physiological shock produced on opening or breaking an electric circuit containing self-induction.
- Operator's Head Telephone.**—A head-gear telephone.

- Operator's Position.**—The space or position allotted to each operator in front of a multiple telephone switchboard.
- Operator's Set.**—A telephone set at a central station employed by the operator.
- Operator's Shelf.**—A shelf at, on, or above a multiple telephone switchboard for supporting the apparatus used by the operators.
- Ophthalmoscope.**—An apparatus for examining the living retina.
- Ophthalmoscopic.**—Of or pertaining to the ophthalmoscope.
- Opposed Electromotive Forces.**—Electromotive forces that are opposed either to each other or to some other already existing electro-motive force.
- Opposed Magnetomotive Forces.**—Magnetomotive forces that are opposed either to each other, or to some other already existing magnetomotive force.
- Optic Angle.**—The angle contained between the optical centres of both eyes at any point to which they may be directed.
- Optic Axis.**—(1) The right line passing through the eye, so that the eye is symmetrical on all of its sides. (2) The axis of symmetry of a crystal. (3) The principal axis of the eye, or its axis of figure.
- Optic Nerve.**—The nerve of vision.
- Optics.**—That branch of physics which treats of the properties and phenomena of light.
- Optical Bench.**—A graduated support employed for varying the distance between fixed and movable optical appliances.
- Optical Efficiency of Light.**—The ratio between the obscure and the luminous radiation.
- Optical Galvanometer.**—A galvanometer whose indications are based on the magnetic rotary power of liquids.
- Optical Strain.**—A deformation produced in a plate of glass, or other transparent medium, by the action of a stress, attended by a change in some of the optical properties of such medium.
- Optical Telegraph.**—A name sometimes applied to a semaphore.
- Oral Annunciator.**—An electric annunciator that is operated by a puff of breath transmitted through an ordinary speaking tube.
- Ordinary Jacks.**—In a multiple telephone-switchboard, the reduplicated jacks of each subscriber appearing successively in each section, as distinguished from the local or answering jack, which appears at a single panel.
- Ordinary Lines.**—The lines used for conversation in a call-wire system of telephony, as distinguished from the wires employed for calling.
- Ordinate.**—In graphics, a distance taken on a line called the axis of ordinates
- Ordinary Relay.**—A non-polarized relay.
- Organ, Electric.**—A wind organ in which the escape of air into the different pipes is electrically controlled, or propelled.
- Orientation of Magnetic Needle.**—The coming to rest of a magnetic needle in the direction of the earth's magnetic flux.
- Originating Call.**—The call of the subscriber who asks to be connected with some other subscriber, as distinguished from any other call which may follow in the process of securing connection.
- Originating Operator.**—In telephonic communication passing through more than one exchange, the operator who is nearest to the calling subscriber, and consequently the operator who first delivered the call, as distinguished from other operators whose assistance may have been called in.
- Oscillating Current.**—(1) An oscillatory current. (2) A periodically alternating current usually of diminishing amplitude.
- Oscillating-Current Transformer.**—A transformer operated by an oscillating current.
- Oscillating Discharge.**—An oscillatory discharge.
- Oscillating Needle.**—A needle of oscillation.
- Oscillation.**—A to-and-fro motion or vibration.
- Oscillation of a Function.**—The difference between the greatest and the least values which a function assumes in a given interval.
- Oscillations, Electric.**—(1) The series of partial intermittent discharges of which the apparent instantaneous disruptive discharge of a Leyden jar, through a small resistance, consists. (2) Free electric vibrations of a disturbed electric system. (3) Electric surgings.
- Oscillator.**—Any device for producing oscillations.
- Oscillator, Electric.**—A device for producing electric currents of a constant period, independently of variations in its driving force.
- Oscillatory.**—Vibratory, or characterized by periodic to-and-fro movements.
- Oscillatory Charging.**—Charging by

- means of an oscillatory electromotive force or current.
- Oscillatory Current.**—A current which oscillates or performs periodic vibrations usually of diminishing amplitude.
- Oscillatory Discharge.**—(1) An apparently instantaneous discharge of a Leyden jar or condenser, which in reality consists of a number of successive discharges. (2) A discharge which periodically decreases by a series of oscillations.
- Oscillatory Dynamo.**—A dynamo whose armature coils have electromotive forces generated in them by a vibratory or oscillatory motion through a magnetic field, instead of the usual rotary motion.
- Oscillatory Electric Displacement.**—A displacement of an oscillatory character produced in a dielectric.
- Oscillatory Electric Inductance.**—Oscillatory inductance.
- Oscillatory Electromotive Force.**—A rapidly periodic electromotive force, usually rapidly diminishing in amplitude.
- Oscillatory Generator.**—An oscillatory dynamo.
- Oscillatory Inductance.**—Inductance in the circuit of electric oscillations.
- Oscillatory Induction.**—A name sometimes applied to open-circuit induction.
- Oscillatory Intermittent Currents.**—Intermittent currents which are oscillatory in character, such as the oscillatory discharges of a static machine.
- Oscillograph.**—(1) An instrument for recording rapid variations of an electrical current or pressure, usually consisting of a combination of a suitable form of galvanometer with a photographic recording apparatus. (2) A cathode-ray tube in which the cathode rays are deflected by the application of a magnetic field.
- Osmometer.**—An apparatus for measuring osmose.
- Osmose.**—An unequal mixing of liquids of different densities through the pores of a separating medium.
- Osmose, Electric.**—The unequal difference of diffusion between two liquids placed on opposite sides of a diaphragm, produced by the passage of an electric current through the diaphragm.
- Osmosis.**—A term sometimes used for osmose.
- Osmotic.**—Of or pertaining to osmose.
- Osmotic Pressure.**—(1) The pressure produced by osmose. (2) The virtual gaseous pressure of a dissolved substance.
- Osmotic Pressure.**—(1) Pressure produced by osmose. (2) Pressure in a solution due to the presence of a dissolved substance.
- Osteotome, Electric.**—An electrically propelled circular saw employed in the surgical cutting of bones.
- Outboard Bearing.**—(1) A journal bearing projecting beyond the base frame of a machine for giving adequate support to a long or heavy shaft. (2) A separate journal bearing supported outside the frame of a machine.
- Outboard Bearing of Dynamo-Electric Machine.**—(1) A bearing projecting beyond the base frame of a dynamo-electric machine for the purpose of adequately supporting the rotor. (2) A bearing for the shaft of a dynamo rotor supported independently of the base of the dynamo.
- “Out-Current” of Telephone Relay.** The current which is sent out by a telephone relay or repeater.
- “Out-Door” Transformer.**—A transformer placed outside a building on the sides of its walls, or on suitably selected posts.
- Outers.**—(1) The outside conductors of a three-wire system as distinguished from the neutral conductor. (2) In telephony, the external pair of springs of a telephone jack.
- Outgoing Call.**—A call issued from an exchange, as distinguished from an incoming call.
- Outgoing-Call Trunk-Line.**—A trunk line terminating at a central telephone station and conveying calls which are transmitted from the station, as distinguished from an incoming call line on which such calls are received.
- Outgoing Current.**—The current sent out over a line from a station as distinguished from the received current, or the returning current.
- Outgoing End.**—The end of a junction telephone wire at which calls are transmitted.
- Outgoing Lines.**—(1) Lines in a telephone exchange on which calls are forwarded or transmitted, as distinguished, from incoming lines. (2) Outgoing wires.
- Outgoing Side of Telephone Switchboard.**—(1) The side of a switchboard at which the conductors leave it. (2) The side of a switchboard to which calls are transferred or from which calls are transmitted.
- Outgoing Signals.**—Signals sent out over

- a telegraphic line by the outgoing currents.
- Outgoing Wires.**—Wires by means of which the current is led out from a generator or station.
- Outlet.**—(1) A place where branch wires come out in a wall or ceiling for connection to a switch, lamp or other device. (2) In a system of incandescent-lamp distribution, the places in a building where the fixtures or lamps are attached.
- Outlet Block.**—(1) A fuse block placed at or near an outlet. (2) A block containing an outlet fuse wire.
- Outlet Box.**—A box placed at or near an outlet for the ready making or changing of electric connections with the outlet conductors.
- Outlet Insulator.**—Any insulator employed at an outlet.
- Output.**—The useful energy or activity given out by any machine.
- Output of Dynamo-Electric Machine.**
(1) The electric power of the current developed by a dynamo-electric generator or transformer, at its delivery terminals expressed in volt-amperes, watts, or kilowatts. (2) The available mechanical power developed by a motor, or the power delivered at its pulley or shaft.
- Output Wires.**—Wires connected with a distribution box which take their supply from the box.
- Outtrigger.**—An arm horizontally fastened to a pole for the purpose of trussing it.
- Outtrigger for Arc-Lamp.**—A device for suspending an electric arc-lamp so as to cause it to stand out from the wall of a building.
- Outrigger Torpedo.**—A pole or spar torpedo.
- Outside Wiring.**—(1) Any wiring for a circuit outside of a house or other building. (2) Out-door wiring.
- Outside Work.**—Out-of-door wiring.
- Over-Compounded.**—Such a compounding of a dynamo-electric machine as produces under an increase of load an increase of voltage at its terminals.
- Over-Compounded Dynamo.**—A dynamo in which the magneto-motive force of its series coils not only compensates for the drop in the armature, but also for the drop in a conductor leading from the generators to the motors or translating devices, thus permitting the external conductors to be regarded electrically as forming an extension of the armature winding, and thus permitting the generator to deliver a constant pressure at its final terminals at the motor or device.
- Overflow of Leyden Jar.**—A term sometimes employed for the discharge of a Leyden jar by a disruptive discharge around its edge.
- Overhead Conductor.**—An aerial conductor.
- Overhead Feeders.**—Aerial feeders, as distinguished from buried or underground feeders.
- Overhead Lines.**—A term applied to aerial telegraph, telephone, electric light or power lines, that run overhead, in contradistinction to similar underground lines.
- Overhead Mains.**—Any system of aerial mains.
- Overhead Switch.**—(1) A switch controlling an overhead circuit. (2) A canopy switch. (3) A switch placed overhead. (4) A switch placed above a motor-man on a car so as to be within his reach.
- Overhead Trolley-System.**—(1) An aerial trolley wire system. (2) A system of electric-street-car propulsion in which the required current is taken from an overhead trolley-wire.
- Overhead Trolley-Wire.**—An ordinary aerial trolley wire.
- Overhead Trolley.**—A trolley employed in an overhead trolley-system.
- Overhead Wires.**—Aerial wires.
- Overland Telegraph.**—Any telegraphic circuit provided with aerial conductors, as distinguished from a submarine or an underground telegraph.
- Overlap Test.**—A localization test for a single fault in a single telegraph line, by observing the resistance from each end and deducting therefrom half of the amount by which the sum of these resistances overlap the total conductor resistance of the line, to determine the position occupied by the fault.
- Overlap Splice.**—A splice of a rope or cable in which the strands of one part overlap the parts of the other, as distinguished from a splice in which the strands of both parts interlace.
- Overlapping Block System.**—An electrically operated block system in which the signals automatically delivered by a train occupying one section, appear at a considerable distance behind the train on the preceding section.
- Overlapping Winding of Alternator Armature.**—A winding in which the successive coils overlap, as distinguished

- from a winding in which successive coils are mechanically separated.
- Overload.**—(1) Any load whose value exceeds that of the normal. (2) An excessive load.
- Overload of Electric Motor.**—(1) A load greater than that which an electric motor can carry with its greatest efficiency of operation. (2) Any load which causes injurious heating of a motor. (3) Any load exceeding the full load for which a motor is designed.
- Overload Storage-Battery Switch.**—A switch placed in a discharging circuit of a storage battery, arranged so as to automatically break the circuit of the battery should the discharge become excessive.
- Overload Switch.**—A switch designed to automatically open a circuit upon the occurrence of an overload.
- Over-Load Switch of Accumulator.**—(1) A switch inserted in the circuit of a storage battery which automatically opens or introduces resistance into the circuit when the current becomes excessive. (2) An overload storage-battery switch.
- Overloaded Conductor.**—A conductor carrying any electric current heavier than the normal current for which it was intended.
- Over-Maximal Contraction.**—An increase in the electric stimulation of a motor nerve beyond the point where an apparent maximum stimulus has been reached.
- Over-Running of Incandescent Lamps.**—The operation of incandescent lamps at a pressure above the normal.
- Over-Running Trolley.**—An overhead trolley, as distinguished from an underground trolley.
- “Overshoot.”**—To err in compensation by exceeding in adjustment, so as to overpass the limit.
- Overtone Currents.**—Electric currents of harmonic frequencies accompanying a fundamental periodic current.
- Overtones.**—Additional faint tones of higher frequency than the fundamental, and some multiple thereof, associated with the fundamental and tending to give it its characteristic quality.
- Overtones, Electric.**—Electric upper harmonics or rates of alternation higher than the fundamental rate.
- Overtype Dynamo.**—A dynamo-electric machine whose armature bore or chamber is placed above the field-magnet coils instead of below them.
- Overtype Magnet.**—A form of horseshoe bi-polar electro-magnet, standing vertically over the armature between its poles.
- Over-Winding of Series Motor.**—A series motor whose series-field winding is unduly strong.
- Over-Wound Motor Field.**—(1) A motor field so wound that its full strength is nearly attained with considerably less than the normal current. (2) A term sometimes employed for an over-compounded motor field.
- Oyster Fitting.**—A form of incandescent lamp-fitting employed on board a ship for water-tight bulkheads which cannot be pierced.
- Ozite.**—A form of insulating material.
- Ozokerite.**—A form of insulating material.
- Ozone.**—An allotropic modification of oxygen which possesses more powerful oxidizing properties than ordinary oxygen, and formed by electric discharges in air.
- Ozonizer.**—An apparatus for producing ozone by means of electric discharges.

P

- P.**—A symbol for power.
- P.**—A symbol for electric power.
- P.**—A symbol proposed for pressure.
- Φ .—A symbol for quantity of magnetic flux.
- P. C.**—A contraction for primary current.
- P. D.** or **p. d.**—A contraction frequently employed for potential difference.
- P. P. D.**—A contraction for primary potential difference.
- Pacinotti Projections.**—Radial projections or teeth, in an armature core, so extending from the central shaft as to form slots, pockets or armature chambers, for the reception of the armature coils.
- Pacinotti Ring.**—A ring-shaped armature-core provided with projections employed by Pacinotti to receive the armature windings in his generator.
- Pacinotti Teeth.**—A term sometimes used for Pacinotti projections.
- Packing of Telephone Dust Transmit-**

- ter.**—The partial cohering of the particles of granulated carbon in a dust transmitter into a solid cake, thus seriously injuring the delicacy of the apparatus.
- Page Effect.**—Faint sounds produced when a piece of iron is rapidly magnetized and demagnetized.
- Palladium.**—A metal of the platinum group.
- Palladium Alloys.**—Various alloys of palladium with other metals, some of which are entirely devoid of paramagnetic properties, and are, therefore, employed for the hair-springs of watches, in order to render them free from the disturbing influence of strong magnetic fields.
- Palette Combination Wire-Gauge.**—A wire-gauge measurer consisting of a graduated cam pivoted in a frame hook, so that the wire to be measured is gripped between the hook and cam.
- Pan-Cake Armature-Coil.**—A flat armature coil applied to and secured upon the surface of an armature.
- Panel Board.**—A switchboard which is not prepared in one piece, but which is constructed and connected in panels.
- Panel Feeder.**—The feeder connected with the bus-bars of any particular panel on a switchboard.
- Panel Fuse.**—A fuse placed in the circuit of a particular panel on a switchboard.
- Panel of Switchboard.**—One of the separate vertical sub-sections of a composite constructed switchboard.
- Panel Pressure.**—The pressure which is maintained at a particular switchboard panel.
- Panel Reflector.**—A reflector composed of strips or panels of silvered glass, or other good reflecting material.
- Panelled Conductors.**—Conductors placed in mouldings.
- Panelled Wire.**—Wire placed inside mouldings or panels.
- Pan-Telegraphy.**—Fac-simile or automatic telegraphy.
- Pan-Telephone.**—A name proposed for a certain sensitive form of telephone.
- Paper Cable.**—(1) A paper-insulated cable. (2) A cable in which paper is the solid insulator employed.
- Paper Carbons.**—Incandescent lamp filaments formed of carbonized paper.
- Paper Condenser.**—A condenser in which sheets of paper covered by some good insulating material are employed as a dielectric.
- Paper Cut-Out.**—A term sometimes used for film cut-out.
- Paper-Film Cut-Out.**—A paper or film cut-out.
- Paper Insulation.**—Insulation obtained by paper.
- Paper Perforator.**—An apparatus employed in automatic telegraphy for punching in a strip of paper, the circular or elongated spaces that produce the dots and dashes of the Morse alphabet.
- Paper Telephone Cable.**—A paper-insulated telephone cable.
- Parabolic.**—Of or pertaining to a parabola.
- Parabola.**—A conic section formed by the intersection of a right cone by a plane parallel to any side.
- Parabolic Reflector.**—(1) A reflector or mirror the surface of which is a paraboloid, or such as would be obtained by the revolution of a parabola around its axis. (2) A reflector employed in connection with electro-magnetic radiation of which the section perpendicular to the long axis has the form of a parabola, the focus of which is occupied by the electric oscillator.
- Paradox.**—(1) Something which seems to contradict the ordinary laws of nature, but which is in reality the expression of such law. (2) A seeming inconsistency, or self-contradiction.
- Paraffine.**—A solid hydro-carbon possessing high insulating powers.
- Paraffined Wire.**—Wire wrapped or braided with some textile material and afterwards coated with paraffine.
- Paraffining.**—Coating or covering with paraffine.
- Paragrele.**—A French term for a lightning rod, intended to protect a field against the destructive action of hail.
- Parallax.**—The apparent displacement of the position of an object, relatively to points in front or behind it, due to a difference in the point of view.
- Parallax Error.**—An error in reading the position of a pointer on a scale due to parallax.
- Parallel Arc-Circuit.**—A word sometimes used for multiple circuit.
- Parallel Circuit.**—A term sometimes used for multiple circuit.
- Parallel Conical Conductors.**—A system of conical conductors, or of conductors successively diminishing in diameter, employed in parallel distribution.
- Parallel Connected Sources.**—A number of separate sources connected in

- parallel, so as to be capable of acting as a single source.
- Parallel-Connected Triphasers.**—Two or more triphasers connected in parallel to a common set of triphase bus-bars or mains.
- Parallel-Connections of Alternators.**—A number of alternators connected to a single pair of leads or bus-bars in parallel or multiple-arc.
- Parallel Coupling.**—A term sometimes employed for the parallel connection of alternators.
- Parallel Distribution.**—A distribution of electric energy in which the receptive devices are arranged between one or more pairs of parallel conductors, extending to the limits of the system.
- Parallel Feeding.**—(1) Furnishing the current required for the operation of a number of receptive devices connected in parallel. (2) Multiple-arc distribution in which a pair of mains is supplied at one end as distinguished from an anti-parallel system.
- Parallel-Series.**—A term sometimes applied to a multiple-series connection.
- Parallel Transformer.**—(1) A transformer connected with a parallel-system of distribution. (2) A transformer that is connected to mains in parallel. (3) A transformer whose secondary coils are connected in parallel.
- Parallel Tree-Circuit.**—A system of parallel distribution in which the distributing mains diverge and ramify from a common centre or central station, diminishing in size as they proceed.
- Parallel-Wire Stretcher.**—A clamping tool for gripping and stretching wire.
- Parallel-Working of Dynamo-Electric Machines.**—The working of two or more dynamos in parallel.
- Parallelogram of Forces.**—A parallelogram whose sides represent in length and direction the intensity and direction of two co-acting forces, and whose intermediate diagonal represents the resultant force.
- Paramagnet.**—(1) A magnet produced by iron or other magnetic substance. (2) A ferromagnet.
- Paramagnetic.**—(1) Possessing the properties ordinarily recognized as magnetic. (2) Possessing the power of concentrating lines of magnetic force. (3) Ferromagnetic.
- Paramagnetic Permeability.**—Permeability to magnetic force.
- Paramagnetic Polarity.**—Magnetic polarity, or the polarity possessed by paramagnetic substances.
- Paramagnetically.**—In a paramagnetic manner.
- Paramagnetism.**—The magnetism of paramagnetic substances.
- Parasitical Currents.**—A name sometimes applied to eddy currents.
- Paratonnere.**—A French term for lightning rod, sometimes employed in English technical works.
- Parcel of Wire.**—A word sometimes employed for any quantity of manufactured wire presented at one time and in one piece for examination or testing.
- Parchmentized-Thread Filament.**—A filament for an incandescent lamp made from the carbonization of parchmentized thread.
- Parchmentizing Process.**—A process for converting cellulose thread into artificial parchment by treating it with dilute sulphuric acid.
- Partial Contact.**—(1) A high-resistance or imperfect contact between two telegraphic lines or circuits. (2) An incomplete contact.
- Partial Disconnection.**—(1) A partial discontinuity. (2) A loss of complete metallic connection. (3) An imperfect metallic contact.
- Partial Earth.**—The fault in a telegraphic or other line in which the line is in partial connection with the earth.
- Partial Fault.**—In telegraphy or telephony, a fault due to an imperfect ground-contact, a cross-contact or a disconnection, as distinguished from a complete fault or one that interrupts communication.
- Partial Reaction of Degeneration.**—That form of alteration to electric stimulation in which the nerves show no abnormal reaction to electric stimulation, while the muscles, when directly stimulated by a constant current, exhibit the reaction of degeneration.
- Partial Vacuum.**—An incomplete vacuum.
- Partially Overlapping Winding of Alternator Armature.**—A winding in which some of the coils overlap each other and some of the coils do not overlap.
- Parting of Cable.**—A complete rupture or breaking of a submarine cable.
- Party Lines for Telephone Service.**—(1) Lines which connect several subscribers in one circuit, as opposed to lines

devoted to a single subscriber. (2) Lines connecting permanently together several telephonic stations, as distinguished from lines connecting each telephone station through an exchange.

Partz Gravity Cell.—A zinc-carbon couple employed with electrolytes of sulphate of magnesia or common salt, and sulpho-chromic salt, in which the liquids are kept apart by their difference of density.

Passive Resistance.—A term sometimes used for ohmic resistance.

Passive State.—A condition of a metallic substance in which it may be placed in liquids that would ordinarily combine with it, without being attacked or corroded.

Paste Joint for Lamp Filament.—A form of joint between the leading-in wires and the ends of the lamp filament obtained by the employment of a moist hydro-carbon paste which is subsequently carbonized.

Pasted Secondary Cell.—A secondary cell in which the active material is applied to the surface of the grid or support in the form of a paint, paste, or cement.

Path of Magnetic Leakage.—A side path taken by deviating magnetic flux, as distinguished from the main path of usefully employed flux.

Patrol Alarm-Box.—In a system of signal telegraphy or telephony, a box from which a call, communication, or alarm can be given by a patrol.

Paying-Out.—The operation of passing submarine cable out of the ship while laying it.

Paying-Out Drum.—A drum employed in laying a submarine cable and over which the cable takes several turns, whereby, by means of brakes, tension may be applied to the cable as it leaves.

Paying-Out Leg.—In a bight of cable at the bows of a cable ship, that side or leg which is paid out, as distinguished from the side or leg which is held stationary or picked up.

"Pea" Lamp.—A term sometimes given to a particular form of miniature incandescent lamp.

Peaked Type of Periodically-Alternating Electromotive Force.—A type of electromotive force whose curve of graphical representation has a peaked shape, as opposed to a smooth or a flat shape.

Pear Push.—A pear-shaped push-contact,

usually provided with a flexible cord pendant.

Pedestal of Armature.—A supporting pillar for an armature bearing.

Peg-Circuit.—A circuit that is opened or closed by means of metallic pegs.

Peg-Switch.—(1) A switch that is opened or closed by means of a peg. (2) A pin switch.

Peg-Switchboard.—A switchboard whose circuits are capable of being variously inter-connected by means of peg-switches.

Peltier Effect.—The heating effect produced by the passage of an electric current across a thermo-electric junction, or surface of contact between two different metals, as distinguished from a Joulean effect or heat due to resistance merely.

Peltier's Cross.—A cross, made by placing two plates of dissimilar metals in contact at right-angles to each other, employed for the study of the Peltier effect.

Pen Carriage.—The carriage in an electric chronograph which carries the pen and moves over the sheet of paper on which the record is made.

Pen, Electric.—A device for manifold copying, in which a sheet of paper is made into a stencil by minute perforations obtained from a needle driven by a small electric motor, the stencil being afterwards employed in connection with an ink roller for the production of any required number of copies.

Pencil Microphone.—A carbon microphone in which the loose carbon is in the form of one or more pencils.

Pendant Argand.—An Argand burner so arranged as to be lighted or extinguished by the pulling of a pendant.

Pendant Cord.—A flexible conductor provided for conveying the current to a pendant lamp or push.

Pendant, Electric.—A hanging fixture provided with a socket for the support either of an incandescent lamp, or of a contact.

Pendant Electric-Lamp.—An incandescent lamp supported on a pendant cord.

Pendant Pull-Switch.—A switch which is operated by pulling upon a pendant cord or loop.

Pendant Socket.—An attachment provided with a chain or chains for turning on or off a lamp not readily accessible.

Pendulum Annunciator.—(1) An annunciator whose indicating arm consists of a pendulous or swinging arm which, when at rest, assumes a vertical position,

- and which is moved to the right or left by the action of the current. (2) A swinging annunciator.
- Pendulum, Electric.**—(1) A pendulum so arranged that its to-and-fro motions send electric impulses over a line, either by making or breaking contacts. (2) An electric tuning fork whose to-and-fro movements are maintained by electric impulses.
- Pendulum Indicator.**—A term sometimes employed for a pendulum annunciator.
- Pendulum Myograph.**—An electric pendulum employed for physiological and chronographic purposes.
- Pendulum Selector.**—In a system of selective telephony, a pendulum which is adjusted to vibrate at different rates and thereby actuate the call-bell of some particular station selectively.
- Pendulum Signaller.**—A pendulum armed with a contact maker for closing a circuit and transmitting signals.
- Pentad Atom.**—An atom whose valency or atomicity is five.
- Pentane Standard.**—A standard source of light obtained from the burning of pentane, and used in photometric measurements in place of a Methven screen.
- Penthode Working.**—A five-way mode of telegraphic working obtained by the use of the Delany synchronous multiplex telegraph.
- Penumbra.**—A region of partial shadow surrounding the umbra or complete shadow, obtained when the source of light causing the shadow has an appreciable area.
- Percentage Conductivity.**—The conductivity of a wire expressed in percentage of the conductivity of Matthiessen's standard.
- Percentage Conductivity of Wire.**—(1) The conductivity of a wire in terms of the conductivity of pure copper. (2) The conductivity of a particular copper wire compared with the conductivity of a standard wire of the same dimensions. (3) The conductivity of a wire referred to Matthiessen's standard of conductivity for copper.
- Perfect Linkage.**—Linkage of magnetic flux between two associated coils or circuits unaccompanied by magnetic leakage, or such that all of the flux is linked with all the turns of each circuit.
- Perforated Armature.**—An armature provided with perforations for the insertion of the coils.
- Perforated Core-Discs.**—The separate core discs of a laminated armature core provided with perforations for the insertion of armature wires.
- Perforator.**—(1) A paper perforator. (2) In automatic telegraphy, an apparatus for perforating paper.
- Perforator Mallet.**—A mallet used with a perforator for striking its keys.
- Perforator Slip.**—The slip of paper prepared for use in a perforator.
- Period.**—(1) The interval of time between two successive passages of a vibration through a given point of its path taken in the same direction. (2) The time occupied in performing a complete cycle.
- Period of Open-Circuit Oscillation.**—The time in which the oscillation set up in an open circuit by electric resonance requires to make one complete to-and-fro motion.
- Period of Simple-Harmonic Motion.**—The interval of time which elapses between two successive passages of a moving particle over the same point in the same direction.
- Period of Vibration.**—The time occupied in executing one complete vibration or motion to-and-fro.
- Periodic.**—Of or pertaining to a period.
- Periodic Alternating Electromotive Force.**—An electromotive force whose direction periodically varies.
- Periodic Current.**—(1) A current whose strength and direction periodically vary. (2) A simple harmonic or sinusoidal current. (3) A periodically alternating current.
- Periodic Discharge.**—(1) An electric discharge which periodically changes its direction. (2) An alternating discharge.
- Periodic Governor.**—A form of governor for an electric motor, in which the current is automatically cut off for a certain portion of each revolution.
- Periodic Motion.**—A term sometimes employed for simple-periodic motion.
- Periodically Alternating Discharge.**—An alternating discharge.
- Periodically Decreasing Discharge.**—An oscillatory discharge whose successive oscillations decrease in intensity.
- Periodicity.**—(1) The number of periods executed per second by a periodically alternating quantity. (2) The number of cycles executed in unit time by an alternating current. (3) The frequency of an alternating current.
- Periodicity of Alternation.**—(1) The

- number of alternations per second. (2) The frequency. (3) The number of alternations executed per second or per minute.
- Periodicity of Auroras, Magnetic Storms, and Sunspots.**—Coincidences between the occurrence of auroras, magnetic storms and sun-spots.
- Peripheral Speed.**—The speed of a point on the circumference of a rotating cylinder or wheel.
- Peripheral Velocity.**—(1) The rate of linear peripheral speed. (2) The tangential velocity at a periphery.
- Periphatic Region.**—A region which encloses other regions within itself.
- Peripolar Zone.**—The zone or region surrounding the polar zone on the body of a patient undergoing electro-therapeutic treatment.
- Periscopic Eye-Piece of Microscope.**—An eye-piece consisting of a triple eye-lens and a single field-lens, possessing a very large and flat field.
- Permanency, Electric.**—The property possessed by most metallic substances, while in a solid state, of retaining a constant electric conducting power at the same temperature.
- Permanent Charge by Induction.**—An induced charge permanently communicated to a conductor, as distinguished from a temporarily induced charge.
- Permanent Currents of Wheatstone System.**—(1) In the Wheatstone automatic system the use of a signalling current during the whole period in which a signal is transmitted. (2) The continued application of current in one or other direction on the line.
- Permanent Current Telephone Working.**—A system of telephony employing a constant normal strength of current on the line.
- Permanent Electret.**—A body whose molecules are permanently and inherently electrized, as distinguished from a body whose molecules are only inherently electrized while under the influence of some change of state.
- Permanent Intensity of Magnetization.**—A term employed for the intensity of a permanent magnetism produced in hard steel, as distinguished from the magnetization produced temporarily in soft iron.
- Permanent Laminated Magnet.**—A term sometimes employed in place of compound-magnet.
- Permanent Magnet.**—A name sometimes given to a magnet composed of hardened steel, whose magnetic retentivity is high.
- Permanent-Magnet Voltmeter.**—A form of voltmeter in which difference of potential is measured by the movement of a magnetic needle under the combined action of a coil and a permanent magnet, against the pull of a spring.
- Permanent Magnetism.**—Magnetism possessed by permanent magnets.
- Permanent Magnetization.**—(1) A term employed for the magnetization produced in a mass of steel or hardened iron when brought into a magnetic field. (2) The magnetization of a permanent magnet.
- Permanent Magneto-Motive Force.**—The magneto-motive force of a permanent magnet.
- Permanent State of Charge on Telegraphic Line.**—(1) The condition of the charge on a telegraphic line during the time the current passing is at full strength in all parts. (2) The charge in a telegraph line when insulated at one end and connected to an E. M. F. at the other.
- Permanent System of Currents.**—(1) A term sometimes used in telegraphy to represent the current sent into a line by a double-current key. (2) In a Wheatstone's automatic telegraph system the use of double currents, whereby a current is always flowing on the line.
- Permanent Telegraphic Line.**—A term employed for a telegraphic line that is intended to remain in use for an indefinite time, in contra distinction to a semi-permanent line which is only designed for use during a comparatively limited time.
- Permanent Telegraphic Signals.**—Telegraphic signals that are permanently recorded as distinguished from transient or unrecorded signals.
- Permeability Bridge.**—A device for measuring the magnetic permeability of a medium, operating on the principle of a Wheatstone bridge.
- Permeability Curve.**—A curve representing the permeability of a magnetic substance.
- Permeameter.**—An apparatus for determining magnetic permeabilities by the measurement of the tractive force required to detach a mass of soft iron having a plane surface, from a magnetic pole whose magnetic flux passes perpendicularly through the surface.
- Permeance, Magnetic.**—(1) The reciprocal of magnetic reluctance. (2) The conductance of a medium to magnetic flux.
- Permeating.**—(1) The passage of mag-

- netic flux through a magnetizable substance, or of electrostatic flux through a dielectric. (2) Intimately traversing the depths of a medium.
- Permeation.**—The passage of magnetic flux through any permeable substance.
- Permissive Block-System for Railroads.**—A block-system in which two or more trains are, under certain conditions, permitted to occupy the same block simultaneously.
- Permissivity.**—A word frequently used for permittivity.
- Permittance.**—(1) Electrostatic capacity. (2) The capability of a condenser or dielectric to hold a charge.
- Permittivity.**—(1) Specific permittance. (2) The dielectric constant.
- Perpendicular.**—(1) At right angles to. (2) A line at right angles to one or more other lines.
- Persistence of Energy.**—The indestructibility of energy.
- Personal Equation.**—A constant observational error peculiar to an observer, and depending upon his psychological condition.
- Perviability.**—A word proposed for permeability to electrostatic flux.
- Perviance.**—(1) Conductance to electric lines of force. (2) The reciprocal of diviance.
- Petticoat Insulator.**—(1) An insulator provided with a petticoat, or deep internal groove, around its lower extremity, or stalk. (2) A line-wire vertical insulator provided with an insulating inverted cup having a form resembling a petticoat. (3) An ordinary telegraph or telephone single-cup insulator.
- Pflügers Law.**—A given tract of nerve is stimulated by the appearance of cathelectrotonus and the disappearance of anelectrotonus, but not by the disappearance of cathelectrotonus and the appearance of anelectrotonus.
- Phantom Circuit.**—(1) Any of the additional circuits established on a telegraphic line by means of any variety of multiplex telegraphy. (2) An imaginary circuit virtually created by multiplexing a telegraph circuit.
- Phantom Streams.**—A term sometimes applied to a variety of the Tesla streaming discharge.
- Phantom Wires.**—(1) A term sometimes applied to the virtual additional circuits or wires obtained in any single wire or conductor by the use of any multiplex telegraphic system. (2) Phantom circuits.
- Phase.**—The fractional part of a period, which has elapsed since a vibrating body last passed through the extreme point of its path in the positive direction.
- Phase Angle.**—The angle of phase, in a simple-harmonic motion, or the angular distance through which the corresponding circularly moving point has passed from the point of last maximum positive elongation.
- Phase Detector.**—A device for determining the phase of an alternating current, electromotive force, or flux.
- Phase Diagram.**—A diagram representing the magnitude and relative phase position of electric pressures or currents.
- Phase-Difference Measurer.**—A device for measuring difference of phase, between any periodically alternating quantities.
- Phase Indicator.**—(1) A device for indicating when the pressure of an alternator is in phase and synchronism with the pressure of the circuit with which it is to be connected. (2) A term sometimes employed for a synchronizer.
- Phase Meter.**—A phase-difference measurer.
- Phase Modification.**—The alteration of the phase of any periodically alternating quantity.
- Phase of Simple-Harmonic Motion.**—The angle through which the corresponding circularly moving point has moved from the point of maximum positive elongation.
- Phase of Vibration.**—(1) The position of the particles in motion in a wave or vibration at any instant of time during the wave period, as compared with their mean position. (2) The phase angle of vibration considered as simple-harmonic motion.
- Phase Regulation.**—The regulation of the phase or phases of alternating currents or E. M. F.'s.
- Phase-Splitter.**—(1) Any apparatus which so acts upon an incoming alternating current that the same current goes out in different branches as a plurality of currents differing in phase. (2) A device for producing a difference of phase between two currents, so as to enable a single-phase induction-motor to be self-starting. (3) A device for making an alternating current split into two or more dephased components.
- Phase Splitting.**—The quality or opera-

- tion of causing a single alternating current to split into a plurality of relatively dephased components.
- Phase Transformation.**—A change of phase obtained by a transformer whereby two-phase currents may be transformed into three-phase currents, or vice-versâ.
- Phase-Windings.**—The separate windings on the armature of a polyphase motor.
- Phasing Current.**—The current produced between two dynamos when thrown into parallel, which arises from their being either not perfectly in phase, or not perfectly equal in pressure, or both.
- Phasing or Wattless-Component.**—A component of alternating current, 90° out of phase with respect to a pressure, and, therefore, indifferent to it in respect to energy.
- Phasing Transformer.**—(1) A transformer capable of effecting a change of phase. (2) A transformer for the supply of multiphase secondary-currents from uniphase primary-currents, or, vice-versâ.
- Phelp's Stock Printer.**—A form of printing telegraph employed in sending stock quotations telegraphically.
- Phenakistoscope.**—An optical toy depending on the persistence of a retinal image, in which the appearance of life is obtained from a succession of suitable pictures that are caused to rapidly pass before the eye.
- Phenomenon.**—Any event observed or known to occur in nature.
- Pherope.**—A name sometimes applied to a telephote.
- Philosopher's Egg.**—A name given to the ovoid or egg-shaped mass of light, that appears when a convective discharge is taken between two electrodes in a partial vacuum.
- Phonautograph.**—An apparatus for the automatic production of the visible tracings of the vibrations produced by any sounds.
- Phone.**—(1) A contraction frequently employed for telephone. (2) A message sent by telephone.
- Phone.**—To send a message by telephone.
- Phoned.**—Communicated by telephone.
- Phonic Wheel.**—A wheel maintained in synchronous rotation by timed electric impulses sent over a telegraphic line, and employed in the Delany synchronous multiplex telegraph system.
- Phoning.**—Communicating by telephone.
- Phonogram.**—A term proposed for a despatch transmitted by means of a telephone.
- Phonograph.**—An apparatus for the recording and reproduction of articulate speech, or of sounds of any character, at any time after their occurrence, and for a number of times.
- Phonograph Record.**—A record obtained by means of a phonograph.
- Phonographic.**—Of or pertaining to the phonograph.
- Phonophore.**—A modified form of harmonic telegraph.
- Phonoplex.**—A general term embracing the apparatus employed in phonoplex telegraphy.
- Phonoplex Telegraphic-Receiver.**—A special form of telephone receiver employed in phonoplex telegraphy, which responds to brief current impulses but not to prolonged impulses.
- Phonoplex Telegraphy.**—A system of double telegraphic transmission, in which telephonic currents, superposed on the ordinary Morse currents, actuate a modified telephonic receiver, and thus permit the simultaneous transmission of two separate messages over a single wire without interference.
- Phonoplex Transmission.**—Double telegraphic transmission obtained by the superposition of telephonic and Morse currents.
- Phonozenograph.**—An instrument devised to indicate the direction of a distant sound.
- Phosphoresce.**—To emit phosphorescent light.
- Phosphorescence.**—The power of emitting light, or becoming luminous by simple exposure to radiant energy.
- Phosphorescence, Electric.**—Phosphorescence caused in a substance by the passage of an electric discharge.
- Phosphorescent.**—Possessing the quality of phosphorescence.
- Phosphorescent Glow.**—A phosphorescent light emitted by the residual atmosphere of a vacuum tube several seconds after an electric discharge has ceased to pass through it.
- Phosphorescent Lamp.**—A lamp whose light is obtained by means of the phosphorescent effects attending electrical discharges through a rarified space.
- Phosphorescing.**—Emitting phosphorescent light.
- Phosphoroscope.**—An apparatus for

measuring the phosphorescent power of any substance.

Phot.—(1) A unit of time-illumination, or the total illumination produced by one lux for one second of time. (2) The lux-second.

Photo-Chemical.—Relating to photo-chemistry.

Photo-Chemical Effect.—Chemical effects produced by the action of radiant energy.

Photo-Chemistry.—The chemistry of the effects of radiant energy.

Photo-Chronograph.—An electric instrument for automatically recording the transit of a star across the meridian.

Photo-Electric.—Pertaining to the combined action of light and electricity.

Photo-Electric Alarm.—(1) An alarm operated by means of a photo-electric cell. (2) A selenium cell proposed for use in connection with the circuit of an electric source and suitable electro-receptive devices, so as to cause the sounding of an alarm on the exposure of one of the faces of the cell to light.

Photo-Electric Battery.—Several photo-electric cells so combined as to be capable of acting as a single source.

Photo-Electric Cell.—A cell capable of producing difference of potential when its opposite faces are unequally exposed to radiant energy.

Photo-Electric Impulsion-Cell.—A photo-electric cell whose sensitiveness to light may be restored by slight impulses, such as mechanical blows or taps, or by electro-magnetic impulses.

Photo-Electricity.—Difference of electric potential produced by the action of light.

Photo-Electromotive Force.—An electromotive force produced by the action of light.

Photo-Engraving.—Engraving effected by the agency of light.

Photo-Fluoroscopy.—The photography of the image obtained on a fluoroscopic screen.

Photographic Meter.—An electric meter producing a photographic record.

Photographic Negative.—A photographic picture whose lights and shadows are reversed with reference to the original.

Photographic Positive.—A photographic picture whose lights and shadows correspond to those in the natural object.

Photometer.—An apparatus for measuring the intensity of the light emitted by any luminous source.

Photometer Bar.—A graduated horizontal bar designed to carry a photometer screen and to indicate by the distance of the screen from the sources of light, the relative intensities of the lights compared.

Photometer Bench.—A photometer bar, with or without accessory photometric apparatus.

Photometer Box.—A darkened box in which is placed the photometer screen or disc.

Photometer Disc.—The photometer screen.

Photometer, Electric.—An electric instrument for measuring the intensity of light or illumination.

Photometer Gallery.—A name sometimes given to a photometric bench.

Photometer Screen.—An opaque or translucent screen, employed in a photometer for measuring the intensity of light, and which receives the two illuminations to be compared.

Photometric.—Of or pertaining to a photometer.

Photometric - Surface of Luminous Source.—A surface formed by the locus of points at the ends of lines, obtained by laying off lines in various directions passing through the luminous source, whose lengths measure the intensity of the rays emitted in these directions.

Photometrically.—In a photometric manner.

Photo-Micrography.—The photography of microscopic objects.

Photo-Micrography, Electric.—The art of photographing microscopic images by means of the electric light.

Photophone.—An instrument for the telephonic transmission of articulate speech along a ray of light instead of along a conducting wire.

Photophone Transmitter.—The transmitter employed in radiophony, in connection with the photophone.

Photophore.—An apparatus in which the light of a small incandescent lamp is employed for purposes of medical exploration.

Photosphere.—The luminous envelope which surrounds the sun, and which is the source of its luminous radiation.

Photo-Telegraphy.—(1) Telegraphic communication carried on by means of light. (2) Heliography. (3) Radiophony.

Photo-Voltaic Cell.—A photo-electric cell.

Photo-Voltaic Effect.—A change in the resistance of selenium or other substance produced by its exposure to light.

Physical Change.—Any change in matter resulting from a re-arrangement of its molecular groupings, without the formation of new molecules, as distinguished from a chemical change.

Physical Equator.—The geographical equator.

Physical Phosphorescence.—Phosphorescence produced in matter by the impact of light waves, resulting in a vibratory motion of the molecules, of a rapidity sufficient to cause them to emit light.

Physical.—(1) Of or pertaining to nature. (2) Natural.

Physiological.—Of or pertaining to physiology.

Physiological Coefficient of Illumination.—The illuminating value of one watt of activity at frequencies within visible limits of the spectrum.

Physiological Rheoscope.—A sensitive nerve-muscle preparation employed to determine the presence of an electric current.

Physiologically.—In a physiological manner.

Physiologically-Effective Flux of Light.—The physiologically-effective illumination received by any surface.

Physiologically-Effective Radiation. That portion of the radiation which consists of physiologically active or luminous frequencies.

Physiology, Electro.—The study of the electric phenomena of living animals and plants.

Piano, Electric.—A piano whose strings are struck by hammers actuated by means of electro-magnets.

Picking-Up Gear.—The gear provided in a cable ship for the recovery of a submerged cable.

Pickle.—An acid solution in which metallic objects are dipped in order to thoroughly cleanse their surfaces before being electro-plated.

Piece of Wire.—A single length of wire without a joint or splice of any description.

Pierced-Core Armature.—A perforated armature core.

Piezo-Electricity.—Electrification produced in certain crystalline substances by pressure.

Piezometer.—An apparatus for determining the compressibility of a liquid.

Pike Pole.—A straight pole armed at one end with a metal point or pike, for use in setting up telegraph poles.

Pile.—(1) A word frequently used for voltaic or thermo-electric pile, though more frequently for the former. (2) A voltaic or thermo-electric battery.

Pilot Brush.—A small accessory brush placed on the commutator cylinder for the purpose of determining the variations in the electromotive force produced in various segments.

Pilot-House Controlling-Gear.—Gear placed in the pilot house for the control of a search-light projector.

Pilot Lamp.—(1) A lamp connected across the terminals of a dynamo to show roughly the pressure which it is producing. (2) A lamp placed in a central station, generally on the dynamo itself, to indicate the difference of potential at the dynamo terminals by means of the intensity of the emitted light.

Pilot Motor.—(1) A small motor which goes ahead of and serves to set in operation a larger or working motor. (2) A small motor whose sole duty is to actuate contacts for controlling the operation of a large motor.

Pilot Transformer.—A small transformer placed at any desired portion of a line in order to determine its pressure.

Pilot Wires.—(1) The wires leading directly to the generating station from different parts of the mains, in order to determine the difference of potential at such parts. (2) Wires provided for connection to a pilot lamp, or other device for indicating the maintenance of normal pressure.

Pins.—Wooden pegs for supporting pole line insulators.

Pin Plug.—A plug consisting of a single metallic pin with or without an insulating head, for bridging a discontinuity in a resistance box or switchboard.

Pipe Conduit.—A conduit formed of suitably prepared metallic pipes surrounded either on the interior or the exterior with a cementing compound.

Pipe Pole.—(1) A pole for aerial wires, formed of iron pipes, usually in lengths or sections of tapering diameter. (2) A pole of iron or steel in tubular form.

Pipette.—A glass tube suitable for holding and removing small quantities of liquid for analytical or other purposes.

Piston Manometer.—A manometer whose operation is dependent on the principle of hydraulic pressure.

Pitch.—(1) The frequency of vibration of a musical tone. (2) The frequency of an electrically produced tone. (3) The distance between successive corresponding points of symmetry in a mechanical system, such as of screw threads or propeller blades. (4) The distance between successive corresponding conductors on a dynamo armature. (5) In an armature winding divided into coils or segments, the number of coils through which advance must be made in making end connections between the coils.

Pitch Line.—(1) A circle upon the periphery of which the pitch is measured. (2) A circle drawn around the external surface of an armature through the middle of the length of the inductors placed thereon.

Pitch of Poles.—The distance measured along the pitch line between the centres either of a pair of poles of opposite sign, or of a pair of poles of the same sign.

Pitch of Windings.—(1) In alternators, usually the distance measured along the pitch line between the centres of a pair of successive poles of opposite sign; or, in some alternators, half this distance. (2) In a continuous-current armature, the pitch.

Pitch-Ratio of Alternator.—The ratio of the width of a pole-piece, or an armature coil, to the pitch of the machine, or distance between successive field-pole centres as measured on the pitch line.

Pith.—A light cellular substance that forms the central portions of the stalls of certain plants.

Pith Balls.—Two balls of pith, suspended from an insulated conductor by conducting threads of cotton, or other semi-conducting substance, and employed for showing the presence of a charge on the same by their mutual repulsion.

Pith-Ball Electroscop.—An electroscop whose indications are obtained by the attractions or repulsions of pith balls.

Pivot Suspension.—Suspension of a needle by means of a jewelled cup and a metallic pivot.

Pivotal Trolley.—A trolley stand in which the pole is supported on a pivot, so as to be capable of rotation, for the purpose of reversing the direction.

Plain-Pendant Argand Electric Burner.—A plain-pendant electric burner suitable for lighting an Argand gas burner.

Plain-Pendant Electric Burner.—A gas burner provided with a pendant for the

purpose of lighting the gas by means of a spark, after the gas has been turned on by hand.

Plaited Electrode Accumulator.—A form of storage cell or accumulator, in which the electrodes consist of plaited strips or ribbons of lead.

Plane Angle.—(1) An angle contained between two straight lines. (2) An angle lying in a plane.

Plane of Polarization of Light.—(1) The plane of incidence in a ray of light polarized by reflection. (2) A plane perpendicular to the plane of vibration of plane polarized light.

Plane Vector.—A quantity which possesses not only magnitude but also direction in a single plane.

Planimeter.—An instrument for automatically integrating the areas of plane curves, around the contour of which a fiducial point on the instrument is carried.

Plano-Concave.—Flat on one side and concave on the other.

Plano-Convex.—Flat on one side and convex on the other.

Plant.—An installation.

Plant Efficiency.—(1) The efficiency of a plant or electric installation. (2) The efficiency of a plant as distinguished from the distribution system which it operates, or by which it may be operated.

Plant Efficiency of Motor.—The efficiency of a motor, as distinguished from the efficiency of the system with which it is connected.

Plant Electricity.—Electricity produced by plants during their growth.

Plastic.—Possessing the property of plasticity.

Plastic-Circuit Microphone.—A microphone which operates by varying the resistance of a plastic circuit.

Plastic Rail-Bond.—In street-railway systems, a rail-bond in which contact is secured with the rail-ends by sodium amalgam, or other conducting material applied in a plastic condition.

Plasticity.—(1) The property of readily changing form under continuous stress. (2) The property of possessing small resistance to distortional stress.

Plate Condenser.—(1) A condenser, the metallic coatings of which are placed on suitably supported dielectric plates. (2) A condenser made up of one or more pairs of conducting plates separated by a plate or plates of non-conducting material.

Plated.—Electro-plated, or covered with an electro-metallurgical coating.

Platform Controller.—An electrical car-controller placed on the platform of a car for the purpose of starting, stopping and regulating the speed of the car.

Platform Coupling.—An electric coupling connecting two cars and placed on or beneath the platform of the cars.

Platinating.—Covering a conducting surface electrolytically with platinum.

Plating.—A word frequently used for electro-plating.

Plating Balance.—An automatic device for disconnecting the current from an article to be plated, as soon as a certain increase in weight has been reached.

Plating Dynamo.—A dynamo employed for furnishing the current required for a plating process.

Plating Trough.—A term sometimes employed for plating bath.

Platinoid.—An alloy consisting of German silver with one or two per cent. of metallic tungsten, whose electric resistivity is only slightly affected by changes of temperature.

Platinum.—A heavy, refractory and not readily oxydizable metal of a tin-white color.

Platinum Alloy.—An alloy of platinum, commonly a platinum-silver alloy.

Platinum Black.—Finely divided platinum that possesses in a marked degree the power of absorbing or occluding gases.

Platinum Fuse.—A thin platinum wire rendered incandescent by the passage of an electric current, and employed for the ignition of a charge of powder.

Platinum-Iridium Alloy.—An alloy of platinum and iridium employed for the manufacture of wire sometimes used in resistance coils on account of its low temperature coefficient of resistivity.

Platinum Lamp.—(1) A lamp whose incandescent filament is formed of a platinum wire. (2) A lamp of molten platinum. (3) A violle.

Platinum-Silver Alloy.—A name usually applied to a particular alloy of one part of platinum and two parts of silver, possessing a low temperature-coefficient of resistivity.

Platinum Standard Light.—(1) The luminous intensity emitted perpendicularly by a surface of platinum one square centimetre in area, at its temperature of fusion. (2) The Violle standard.

Platinum Sulphuric Acid Voltameter.—A platinum voltameter.

Platinum Voltameter.—(1) A voltameter employing platinum electrodes. (2) A voltameter furnished with platinum electrodes immersed in a dilute solution of sulphuric acid and water.

Plating.—(1) Covering a surface electrolytically with platinum. (2) Platinum plating; or, electro-plating with platinum.

Platinizing.—(1) Obtaining a platinum coating of a conducting surface by simple immersion in a solution of a platinum salt. (2) Plating.

Platymeter.—An instrument employed for comparing the capacity of two condensers, or the specific inductive capacities of two dielectrics.

Plow.—A term sometimes employed for the sliding contact and its support that is pushed before a car, along the trolley conductors in an underground trolley system.

Plow, Electric.—An electrically propelled plow employed in agriculture.

Plücker Tube.—A modification of a Geissler tube employed for studying the stratification of the light, and the peculiarities of the space adjoining the negative electrode.

Plug.—(1) A suitably-shaped metallic key provided with an insulating handle and employed for closing or making contacts. (2) An incompetent telegraph operator.

Plug Cut-Out.—A cut-out employing fuse-plugs.

Plug Hole.—The hole provided in a plug switch for the introduction of a plug.

Plug Key.—A key-shaped plug.

Plug Operator.—A term of contempt sometimes applied to an inefficient telegraphic operator.

Plug Resistances.—(1) A number of separate resistances that can be introduced into a circuit by unplugging. (2) The resistances of the ordinary resistance box.

Plug Sleeve.—The contact cylinder on the surface of a telephone-switchboard plug.

Plug Switch.—A switch operated by the insertion of a metallic plug between two insulated metallic segments connected to a circuit, and separated by air-spaces for the reception of the plug key.

Plug Switchboard.—A switchboard whose various circuits are inter-connected by means of plug keys.

Plugging.—(1) Completing a circuit by

- means of plugs. (2) In a telephone switchboard, the operation of making the connections by inserting plugs in the proper jacks.
- Plumbago.**—(1) An allotropic modification of carbon. (2) Graphite.
- Plunge Battery.**—The couples of a voltaic battery so supported on a horizontal bar as to be capable of being simultaneously placed in or removed from the exciting liquid.
- Plunger Door-Contact.**—A form of electric contact for doors in which the closing of the door forces in a small plunger against the tension of a spring, thereby either making or breaking an electric alarm circuit.
- Plunger Floor-Contact.**—A form of plunger contact suitable for being placed on the floor and operated by the foot.
- Plunger Switch.**—A switch, the operating lever cylinder of which passes through a bushing in a switchboard, so as to make and break contacts at the back of the switchboard.
- Plus Charge.**—A positive charge.
- Pneumatic.**—Of or pertaining to pneumatics.
- Pneumatic Car-Brake Mechanism.**—A car-brake operated by air-pressure.
- Pneumatic Perforator.**—A paper perforator operated by compressed air.
- Pneumatic Rodding.**—A method of introducing a cable or wire into the duct of a conduit by the movement of a dart driven through the duct by air pressure.
- Pneumatic Telegraph.**—A form of instrument for transmitting signals by means of air pressure.
- Pneumatic Transmission.**—Transmission of objects or of power, effected by means of compressed air.
- Pneumatics.**—That branch of physics which treats of the properties of gases either at rest or in motion.
- Pocket Galvanometer.**—A galvanometer suitable for carrying in the pocket.
- Pocket Gauge, Electric.**—A rough form of pocket galvanometer.
- Pocket Telegraphic-Relay.**—A relay sufficiently small to be readily carried in the pocket.
- Pockets in Inside Wiring System.**—Hollow spaces provided in the walls, floors or ceilings of a building for drawing wires in, for making connections, or for inserting safety devices.
- Poggendorff's Voltaic Cell.**—The name sometimes given to the Grenêt cell.
- Point Discharge.**—A term sometimes applied to a convective discharge.
- Point of Origin.**—(1) In graphics, the point where the axes of co-ordinates start. (2) The point at which a curve starts.
- Points on Lightning Rod.**—Points of unoxidizable metal placed on lightning rods to effect the quiet discharge of a cloud by convection streams.
- Points of Compass.**—(1) The thirty-two points into which the edge or periphery of a compass card is divided. (2) The rhumbs of a compass.
- Polar.**—Of or pertaining to a pole.
- Pointer Telegraph.**—A term sometimes used for a dial telegraph.
- Polar Aurora.**—A general term for the Northern or Southern light.
- Polar Bore of Field Frame.**—The bore or cylindrical hollow space excavated in a field frame for the reception of an armature.
- Polar Duplex.**—A system of differential duplex-telegraphy employing polar-receiving relays.
- Polar Duplex-Telegraphy.**—Telegraphic communication obtained by means of a differential duplex in which the current flowing from the home battery to line is reversed when the home key is depressed.
- Polar Electrolysis.**—(1) A form of electrolysis attended by destruction of the tissues. (2) Galvano-Caustics.
- Polar Relay.**—In telegraphy, a relay having a normally polarized armature, as distinguished from a neutral relay, in which the armature is normally in neutral magnetic condition.
- Polar Surface of Magnet.**—(1) The surfaces of one or both poles of a magnet. (2) A surface of magnetic material from which or into which magnetic flux passes.
- Polar Tips.**—The free ends of the field-magnet pole-pieces of a dynamo-electric machine.
- Polar Transformer.**—A term sometimes employed for an open-circuit transformer.
- Polar Variation Diagram.**—A diagram drawn to polar co-ordinates and representing some relation between periodically varying quantities.
- Polar Zone.**—The zone or region in the human body surrounding a therapeutic electrode.
- Polariscope, Electric.**—An electric apparatus for polarizing electro-magnetic waves and for revealing the presence of polarization.

Polarity.—(1) The possession of poles, or of opposite properties, at opposite ends.

(2) The condition of electric or magnetic differentiation between properties of electric or magnetic flux depending on and inherent in the direction of such flux.

Polarity Indicator.—Any device for determining the direction of a current or the polarity of a magnet.

Polarization Battery.—A term sometimes employed for a secondary or storage battery.

Polarization Current.—In electro-therapeutics the constant current which, when passed through a nerve, produces therein the electro-tonic state.

Polarization Current from Fault in Cable.—A current due to the polarization of a fault or break in a cable under the action of a testing current.

Polarization, Electric.—(1) In dielectrics, the condition of being subjected to electrification. (2) In dielectrics, the condition of containing or restoring a residual charge. (3) In electrolysis, the condition of having free ions liberated at the electrodes, whereby a C. E. M. F. is set up.

Polarization Fault-Current of Cable.—A current produced in a cable due to the counter-electromotive force set up in a fault under the action of a signalling, testing, or natural current.

Polarization of Dielectric.—(1) A molecular strain produced in the dielectric of a Leyden jar, or other condenser, by the attraction of the electric charges on its opposite faces, or by electrostatic stress. (2) A term sometimes employed for electric displacement.

Polarization of Electrolyte.—An assumed formation of molecular groups or chains in which the poles of all the molecules of any chain are turned in the same direction, that is with their positive poles facing the negative plate, and their negative poles facing the positive plate.

Polarization of Light.—The condition of a ray of light in which the vibrations of the ether by which the light is propagated are all limited to a single plane, the plane perpendicular to which is called the plane of polarization.

Polarization of Voltaic Cell.—The collection of a gas, generally hydrogen, on the surface of the negative element of a voltaic cell.

Polarization Battery.—A term sometimes used for secondary or storage battery.

Polarization Photometer.—A photo-

meter in which the illumination of the stronger of two luminous sources to be compared is reduced by polarization.

Polarized Armature.—An armature which possesses a polarity independently of that imparted by the working current.

Polarized Bell.—An electro-magnetic bell provided with a polarized armature.

Polarized Indicator.—Any electro-magnetic indicator employing a polarized armature.

Polarized Ink-Recorder.—An ink-recorder employing a polarized armature.

Polarized Radiation.—Any radiation whose waves are polarized, or restricted to a particular plane of vibration.

Polarized Relay.—(1) A telegraphic relay provided with a permanently magnetized armature in place of the ordinary soft-iron armature. (2) A polar relay. (3) A non-polarized or neutral relay, as distinguished from a polarized relay.

Polarized Ring-Off Drop.—A ring-off drop in a telephone switchboard having a polarized armature.

Polarized Sounder.—A telegraphic sounder employing a polarized armature.

Polarizing Current.—A current which produces polarization.

Polarizing Spectro-Photometer.—A spectro-photometer employing a polariscope.

Pole Armature.—(1) An armature whose coils are wound on separate poles that project from the periphery of a disc, drum, or ring armature. (2) An armature having polar projections.

Pole Bands.—Metallic bands placed around a pole for the purpose of supporting guy-rods or brackets.

Pole - Changing and Interrupting Electrode Handle.—A handle provided for the ready insertion of the electro-therapeutic electrodes, containing means for interrupting or changing the direction of the current.

Pole Changer.—(1) A switch or key for reversing the direction of a current. (2) A reverser. (3) A generator of alternating currents at a telephone exchange, consisting of an electro-magnetically driven pendulum which periodically reverses a call battery.

Pole-Changing Key.—(1) A pole changer, (2) A key which effects a reversal.

Pole-Changing Switch.—A switch employed for changing the direction of the current in any circuit.

- Pole Clamp.**—An iron clamp on a pole employed for the support of span wires or brackets.
- Pole Climbers.**—Devices employed by line-men for climbing wooden telegraphic poles.
- Pole Clip.**—A pole clamp.
- Pole Counter.**—A hand-operated registering device employed for counting telegraph or other poles.
- Pole Guys.**—A guy employed for the stiffening of a pole.
- Pole Hood.**—A hood or cover placed at the top of a pole.
- Pole Indicator.**—Any device for readily determining the polarity of a pole, of a magnet, or of an electric source.
- Pole-Pieces of Dynamo or Motor.**—A mass of iron or steel connected with the poles of the field-magnets of a dynamo or motor, and shaped to conform to the outline or contour of the armature.
- Pole Platform.**—A platform, capable of supporting one or more men, placed on a terminal pole, and provided with a cable box for the purpose of affording a ready means of inspecting and arranging the conductors in the box.
- Pole Roof.**—A metallic cap or roof of a telegraph or telephone pole.
- Pole Shoe.**—A plate of iron or steel mounted on, and forming the pole-piece of a field magnet, and sometimes used for supporting a field coil.
- Pole Steps.**—Steps permanently fastened to a wooden or iron pole to facilitate climbing.
- Pole Support for Arc-Lamps.**—A support placed on the top or end of a pole for the reception of an arc-lamp.
- Pole Tips.**—A name sometimes employed for the horns of a dynamo field pole.
- Pole Top.**—A fixture for the top of an aerial pole provided with a number of arms and insulators for the support of additional aerial circuits.
- Poles of Condenser.**—The terminals of a condenser.
- Poles of Magnetic Intensity.**—The earth's magnetic poles as determined by means of observations of magnetic intensity.
- Poles of Magnetic Verticity.**—The earth's magnetic poles as determined by means of a dipping needle.
- Poling Boards.**—Short rough boards laid vertically against the sides of an excavation, in packed soil, and kept in place by cross struts.
- Polishing Bob.**—A disc of tough wood provided on its edge with a ring or rim of leather or hide, on which finely divided emery is placed, employed, when mounted on a shaft and put in rapid rotation, for polishing articles so as to prepare them for electro-plating.
- Polishing Mop.**—A disc formed of circular pieces of calico, felt, or other similar soft material, mounted on a shaft and employed, when put in rapid rotation, for polishing surfaces for electro-plating.
- Polycyclic System.**—A multiphase system.
- Polymerism.**—A species of isomerism in which chemical compounds of the same proportional constitution, as determined by analysis, have different properties, due to having different numbers of atoms in their molecules.
- Polymorphic Instrument.**—A term sometimes used for a polymorphic machine.
- Polymorphic Machine.**—An apparatus capable of effecting the transformation of alternating-currents from one species to another.
- Polyphasal Coupling of Magnetic Circuits.**—The inter-linking of magnetic circuits traversed by polyphase magnetic fluxes.
- Polyphase.**—Possessing more than a single phase.
- Polyphase Alternator.**—An alternator capable of supplying polyphase currents.
- Polyphase Apparatus.**—Apparatus operated by polyphase currents.
- Polyphase Armature.**—An armature so wound as either to produce polyphase currents, or to be operated by such currents.
- Polyphase Armature-Windings.**—Windings of polyphase generators.
- Polyphase Asynchronous Motor.**—(1) An asynchronous motor operated by multiphase currents. (2) A multiphase induction motor.
- Polyphase Choking-Coil.**—(1) A choking coil in a polyphase system. (2) A choking coil operated by polyphase currents.
- Polyphase Circuits.**—The circuits employed in polyphase-current distribution.
- Polyphase Currents.**—Currents differing in phase from one another by a definite amount, and suitable for the operation of polyphase motors or similar apparatus.
- Polyphase Dynamo.**—A polyphase generator.
- Polyphase Generator.**—An alternator

- which delivers two or more alternating currents definitely differing in phase.
- Polyphase Inductor - Alternator.**—An inductor alternator suitable for producing polyphase currents.
- Polyphase Inductor-Generator.**—(1) A polyphase generator of the inductor type in which no conductor or winding is rotated. (2) A polyphase inductor-alternator.
- Polyphase Motor.**—A motor operated by means of polyphase currents.
- Polyphase Power.**—Power transmitted by means of polyphase currents.
- Polyphase Rotary - Converter.**—A rotary converter operated by or producing polyphase currents.
- Polyphase Switchboard.**—A switchboard suitable for controlling polyphase circuits.
- Polyphase Synchronous - Motor.**—A synchronous motor operated by polyphase currents.
- Polyphase Transformer.**—A transformer suitable for use in connection with polyphase circuits.
- Polyphase Transmission.**—Transmission of power by means of polyphase currents.
- Polyphase Working.**—A general term employed to express the application of polyphase currents.
- Polyphased Alternating-Currents.**—A term employed for polyphase currents.
- Polyphaser.**—(1) A term sometimes employed for a polyphase alternator, or generator. (2) A multiphaser.
- Polyphotal Arc-Light Regulator.**—A regulator for arc-lamps suitable for use in a number of series-connected arc lamps.
- Poncelet.**—A name proposed for a unit of activity equal to 100 kilogramme-metres per second; or, approximately, one kilowatt.
- Pondermotive Force.**—The force required for the movement of gross matter.
- Pony Insulators.**—A name given to a particular type of glass telegraph insulator.
- Pony Telegraphic Relay.**—A name applied to a particular form of telegraphic relay.
- Porcelain.**—A variety of insulating substance, made from kaolin.
- Porcelain Insulator.**—Any insulator of porcelain for supporting a wire.
- Porcelain Wire-Tube.**—A porcelain tube employed for passing an electric wire through a partition.
- Porosity.**—A property of matter in virtue of which spaces or pores are left between its constituent atoms and molecules.
- Porous Cell.**—A jar of unglazed earthenware employed in a double-fluid voltaic cell to mechanically separate the two electrolytes.
- Porous Cup.**—A porous cell.
- Porous Insulation.**—An insulating material containing air or other gas.
- Porous Jar or Pot.**—A porous cell.
- Porret's Phenomenon.**—An increase in the diameter of a nerve fibre in the neighborhood of the positive pole, when traversed by a voltaic current.
- Portable Conductors.**—Flexible cords containing insulated wires suitable for use with portable lamps, motors, or other devices.
- Portable Electrometer.**—A form of readily transportable Thomson electrometer.
- Portable Igniting Device.**—(1) A portable electric mine-exploder. (2) A portable electric gas-igniter.
- Portable-Lamp Guard.**—A guard provided for the protection of a portable lamp.
- Portable Tachometer.**—A portable speed indicator.
- Portative Power of Magnet.**—The lifting or sustaining power of a magnet.
- Portelectric.**—(1) An electric carrier. (2) A system of electric transportation by means of the successive attractions of a number of hollow helices of insulated wire on a moving iron core.
- Portrait, Electric.**—A portrait formed on paper by the electric volatilization of gold or other metal.
- Position-Finder, Electric.**—An electric device by means of which the position of a distant object can be determined.
- Positive Brush of Dynamo.**—The brush of a dynamo out from which flows the current generated in the armature.
- Positive Brush of Motor.**—The brush connected to the positive terminal of a driving source.
- Positive Carbon.**—That carbon of a voltaic arc out from which the current flows into the arc.
- Positive Charge.**—(1) According to the double-fluid hypothesis, a charge of positive electricity. (2) According to the single-fluid hypothesis, any excess of an assumed electric fluid. (3) A charge of electricity having a positive potential.

- Positive Currents.**—A term employed in telegraphy for currents sent over a line from the positive pole of a battery.
- Positive-Direction of Lines of Magnetic Force.**—The direction in which a free north-seeking pole would move along the lines of force when placed in a magnetic field.
- Positive-Direction of Simple-Harmonic Motion.**—The motion which a body moving with simple-harmonic motion has, when its corresponding circularly moving point moves counter-clockwise.
- Positive-Direction of Electric Convection of Heat.**—A direction in which heat is transmitted through an unequally heated conductor by electric convection during the passage of electricity through the conductor, the same as that of the current.
- Positive-Direction Round a Circuit.**—In a plane circuit looked at from the positive side, a direction opposed to that of the hands of a clock.
- Positive-Direction Through a Circuit.** In a plane circuit carrying a positive current, a direction through the circuit similar to that of the advance of a corkscrew which is twisted round in the direction of the current.
- Positive Electricity.**—(1) One of the phases of electric excitement. (2) That kind of electric charge produced on cotton when rubbed against resin.
- Positive Electrification.**—(1) The charge of a body with positive electricity. (2) A positive charge. (3) An electrification of positive potential.
- Positive Electrode.**—The electrode connected with the positive pole of an electric source.
- Positive Electromotive Force.**—An E. M. F. which will communicate a positive charge.
- Positive Feeders.**—The feeders that are connected with the positive terminal of a dynamo.
- Positive Fluid.**—(1) The specific fluid that was formerly believed by the adherents of the double-fluid electric hypothesis to be the cause of electric excitement. (2) The surplusage of an assumed single electric fluid.
- Positive Lead.**—In a system of parallel distribution, a lead connected with the positive generator-terminal, or with the positive bus-bars.
- Positive Omnibus-Bars.**—The bus-bars that are connected with the positive terminal of a dynamo.
- Positive Phase of Electrotonus.**—An increase in the electromotive force of a nerve produced by sending a current through the nerve in the same direction as the nerve current.
- Positive Plate of Storage Cell.**—(1) That plate of a storage cell which is converted into, or covered by, a layer of lead peroxide by the action of the charging current. (2) That plate of a storage cell which is connected with the positive terminal of a charging source, and which is, therefore, the positive pole of the cell on discharging.
- Positive Plate of Voltaic Cell.**—(1) The electro-positive element of a voltaic couple. (2) That element of a voltaic couple which is positive in the electrolyte of the cell. (3) The plate which forms above the surface of the electrolyte, the negative pole of the cell.
- Positive Pole.**—That pole of an electric source out of which the current is assumed to flow.
- Positive Potential.**—(1) That potential in a circuit external to a source from which the electric current flows. (2) The higher potential or higher electric level.
- Positive Rotation.**—Left-handed or counter-clockwise rotation.
- Positive Side of Circuit.**—That side of a circuit bent in the form of a circle in which, if an observer stood with his head in the positive region, he would see the current pass around him counter-clockwise.
- Positive Spark.**—A spark produced by the disruptive discharge of a positively charged conductor.
- Positive Terminal.**—The terminal connected with the positive pole of a source.
- Positive Wire.**—The wire connected with the positive pole of a source.
- Positively Excited.**—Charged with positive electricity.
- Pot Operator.**—(1) The operator which is the double inverse of the curl operator. (2) The operator which acting upon a point function in space produces its vector potential.
- Potash Brush.**—A brush employed in cleansing, by the use of a caustic solution, surfaces which are to be electro-plated.
- Potential Dynamometer.**—An electro-dynamometer suitably arranged for the measurement of electric potential differences.
- Potential, Electric.**—(1) The power of doing electric work. (2) Electric level.

- Potential Energy.**—(1) Stored energy. (2) Potency or capability of doing work. (3) Energy possessing the power or potency of doing work, but not actually performing such work.
- Potential Function.**—A point function of space, whose space differentiation gives a vector point-function.
- Potential Galvanometer.**—A term sometimes applied to a voltmeter.
- Potential Gradient.**—(1) The rate-of-fall of potential at a point. (2) A line representing the fall of potential in a circuit.
- Potential Indicator.**—An apparatus for indicating potential difference.
- Potential of Conductors.**—(1) The relation existing between the quantity of electricity in a conductor and its capacity. (2) That property of a conductor whereby electric work is done when an electric charge is moved towards it.
- Potential Receptacle.**—A receptacle in a switchboard, wall, cover, base, or other device, for receiving a plug connected to a potential-indicator, or voltmeter.
- Potentiometer.**—An apparatus for the galvanometric measurement of electromotive forces, or differences of potential, by a zero method, and by relation to a standard E. M. F.
- Potentiometer Voltmeter.**—A voltmeter operating on the potentiometer principle and employing a standard voltaic cell as its basis of measurement.
- Potentiometer Wire.**—A graduated wire employed in a potentiometer for the purpose of securing proportionate linear resistances and thereby proportional potential differences.
- Pounds-Per-Mile-Ohm.**—(1) A standard of conductivity of telegraph or telephone wires. (2) The weight of a uniform wire offering one ohm per mile at standard temperature.
- Poundal.**—(1) The weight of a pound, or the earth's attraction upon the mass of a pound of matter, at any terrestrial locality. (2) A gravitational unit of force.
- Power.**—(1) Rate-of-doing-work, expressible in watts, joules-per-second, foot-pounds-per-hour, etc. (2) Activity.
- Power Cable.**—A cable employed for the electric transmission of power.
- Power Circuits.**—Circuits employed for the electric transmission of power.
- Power Coefficient.**—(1) In an alternating-current circuit, the ratio of the power component of electromotive force to the power component of current. (2) The apparent resistance of an alternating-current circuit.
- Power Cylinder.**—The commutating cylinder of a street-car controller as distinguished from the reversing cylinder.
- Power, Electric.**—Power developed by means of electricity.
- Power Electromotive Force.**—A term sometimes employed for that component of the E. M. F. acting in the same direction with the current, or in phase with it, and expended in overcoming effective or ohmic resistance.
- Power Factor.**—The ratio of the true watts to the apparent volt-amperes in an alternating-current conductor, circuit, or device.
- Power-Factor of Transformer.**—The ratio of the true watts absorbed by a transformer under a given load to the apparent watts absorbed.
- Power Generator.**—A generator of alternating currents at a central telephone exchange.
- Power-House.**—A house provided with the plant necessary for the production of the electric power required in a system of electric distribution.
- Power Measurer, Electric.**—A wattmeter.
- Power Meter.**—A wattmeter.
- Power of Periodic Currents.**—With simple-harmonic currents, the product of effective current strength, the driving effective pressure, and the cosine of the difference of phase between them.
- Power-Wire of Monocyclic System.**—The wire or circuit of a monocyclic system employed for supplying currents for the operation of triphase electric motors.
- Poynting's Law.**—At any point in space, electro-magnetic energy moves perpendicularly to the plane containing the lines of electric force and the lines of magnetic force, and the amount of energy per second crossing the unit area of this plane is equal to the product of the intensities of the two forces, multiplied by the sine of the angle between them, and divided by 4π .
- Practical Current.**—A term sometimes employed for the effective current in an alternating-current circuit.
- Practical Solenoid.**—A name applied to an ordinary solenoid, in order to distinguish it from an ideal solenoid.
- Practical Unit of Inductance.**—(1) A unit of length equal to the earth's quadrant, or 10^9 centimetres. (2) The henry.

Practical Unit of Magneto-Motive Force.—A value of magneto-motive force equal to 4π multiplied by an ampere of one turn, or equal to one-tenth of an absolute unit of M. M. F.

Practical Unit of Self-Induction.—A term frequently used for the practical unit of inductance.

Practical Units.—Definitely related multiples or sub-multiples of the absolute or centimetre-gramme-second units.

Preamble.—In telegraphy, the opening words of a despatch containing the names of the sending and delivery stations, the number of words in the message, the code time, and other service instructions, as distinguished from the text of the message.

Prefix.—In telegraphy, a code letter or group of letters prefixed to a message to indicate its nature or relative importance.

Prepayment Meter.—A device whereby a certain electric service is given by means of an electric penny-in-the-slot apparatus.

Presbyopic.—Far-sighted.

Press Button.—A push-button.

Press Message.—(1) A message directed to a newspaper or daily publication. (2) A news message.

Press Telegram.—A press message.

Pressant.—A name proposed for a unit of magneto-motive force.

Pressel.—(1) A press switch or push connected to the end of a flexible pendant conductor. (2) A pendant press-button.

Pressure, Electric.—A term sometimes employed for difference of potential, or electromotive force.

Pressure Equalizer.—(1) An automatic device employed in connection with a storage battery to maintain a uniform pressure at its terminals under different loads. (2) A regulating device employed in a system of electric distribution for maintaining the pressure uniform.

Pressure Indicator.—Any device for indicating the electric pressure in a circuit.

Pressure Panel of Switchboard.—That panel in a switchboard which contains apparatus for measuring the mean electric pressure in the power house.

Pressure Recording-Gauge.—Any form of recording voltmeter.

Pressure Wires.—Small insulated copper conductors, employed in a system of underground street mains, extending from points of junction between the feeders and the mains to the central station, to

indicate in the central station the pressure supplied to the mains.

Pricking Wires.—A method sometimes adopted for locating a wire, by connecting a battery with one pole to earth and the other pole to the wire sought for, by means of a brad-awl or needle inserted through the gutta-percha insulating material.

Primary Admittance.—The admittance of the primary coil or coils of an alternating-current transformer or induction machine.

Primary Ampere-Turns.—The ampere-turns in the primary coil of a transformer.

Primary Battery.—The combination of a number of separate primary cells to form a single electric source.

Primary Cell.—A term sometimes employed for a voltaic cell.

Primary Coil of Transformer.—(1) That coil of an induction coil or transformer on which the primary electromotive force is impressed. (2) The driving coil of a transformer. (3) The coil which receives energy prior to transformation.

Primary Currents.—Currents flowing in a primary circuit, as distinguished from currents flowing in a secondary circuit.

Primary Cut-Out.—A cut-out placed in the primary circuit of a transformer.

Primary Electric Clock.—A term sometimes employed in place of controlling or master clock.

Primary Electric Heater.—A term proposed for the main electric heater in a building.

Primary Electromotive Force.—The electromotive force applied to the primary coil of a transformer.

Primary Element of Induction Motor.—The element connected with the line or lines, as distinguished from the element closed upon itself.

Primary Fuse Box.—A fuse box placed in the primary circuit of an induction coil or transformer.

Primary Impedance.—(1) The impedance of the primary coil of a transformer, or of an induction machine. (2) The impedance of the primary coil of a transformer, or of an induction machine, independent of the reactance of mutual inductance, or the C. E. M. F. of mutual linkage.

Primary Plate of Condenser.—That plate of a condensing transformer in which the inducing charge is placed in order to induce a charge of different potential in the secondary plate.

Primary Spiral of Induction Coil.—The primary of an induction coil or transformer.

Prime Conductor.—The positive conductor of a frictional electric or electrostatic machine.

Prime Flux-Density.—The magnetic density of the prime magnetic flux in a ferric circuit.

Prime Magneto-Motive Force.—The magneto-motive force due to the magnetizing current in a ferric circuit.

Prime Magnetic Flux.—(1) A term employed for the flux produced in a ferric circuit by the prime magneto-motive force, as distinguished from the induced, aligned, or structural magneto-motive force. (2) Magnetizing force as distinguished from magnetic induction.

Prime Motor.—A prime mover.

Prime Mover.—A motor which drives the secondary motors or movers.

Primordial Atoms.—The atoms or compounds into which it has been assumed that the so-called elementary atoms of ordinary matter are broken up by means of the cathode rays.

Principal Circuit.—A main circuit as distinguished from a derivation circuit.

Principal Current.—A main current as distinguished from a derivation current.

Principal Telegraphic Circuit.—A term sometimes used for the main circuit.

Principal Telegraphic Current.—A term sometimes employed for the main current.

Printing Telegraphy.—A system of telegraphy in which the messages received are printed on a paper fillet.

Prism Error of Compass.—The error in a magnetic bearing due to an inaccurate setting of the prism relatively to the compass card.

Probable Error of an Observation.—A magnitude of accidental error in the repeated observation of a quantity, such that it is just as probable that the real accidental error is greater as that it is less than this magnitude.

Probe, Electric.—A metallic conductor inserted in the body of a patient in order to ascertain the position of a bullet or other foreign metallic substance.

Process of Carbonization.—Means for carbonizing carbonizable material.

Production of Cold by Electricity.—The absorption of energy, and consequent reduction of temperature at a thermoelectric junction, by the passage of an

electric current in a certain direction across such junction.

Production of Electricity by Light.—The production of electric difference of potential by the action of light.

Prognosis, Electric.—A prognosis or prediction of the fatal or non-fatal termination of a disease from an electric diagnosis, based on the exaggerated or diminished reactions of the excitable tissues of the body, when subjected to the varying influences of electric currents.

Progression of Magnetic Flux.—In a polyphase motor, the circular motion of the magnetic flux around the field or armature.

Projecting Power of Magnet.—(1) The range within which a magnet produces sensible attraction or repulsion. (2) The power of an electro-magnet to repel a suitably placed armature.

Projection Arc-Lamp.—An arc-lamp suitable for use in a projector or search-light.

Projector, Electric.—A projector or search-light provided with an electric arc-light at its focus.

Projection Armatures.—Slotted armatures in which the width of the slot is sufficiently great to leave a distinct projection in the armature surface as distinguished from tunnel armatures in which the slot is very narrow.

Prony Brake.—A mechanical device for measuring the power of a driving shaft by the application of a brake to the periphery of a wheel firmly keyed on the shaft.

Proof-Plane.—A small insulated conductor employed to take and carry electric charges from the surfaces of insulated charged conductors.

Proportional Coils.—Pairs of resistance coils, generally of 10, 100 and 1,000 ohms each, forming the proportional arms of a balance or bridge, and employed in the box or commercial form of Wheatstone's bridge.

Proportionate Arms.—The two resistances or arms of an electric bridge, whose relative or proportionate resistances only are required to be known, in order to determine in connection with a known resistance, the value of an unknown resistance placed in the remaining arm of the bridge.

Proposed Definition for 2,000 Candle-Power Arc.—(1) Such an arc as will require at ordinary pressures 450 watts activity to maintain it. (2) A 450-watt arc.

Propulsion, Electric.—A general term for driving by electric power.

Prostration, Electric.—Physiological exhaustion or prostration, resembling that produced by sun-stroke, resulting from exposure to an unusually powerful arc.

Protecting Battery.—In submarine cable telegraphy, a battery permanently connected to a faulty cable through a high resistance, for the purpose of sending a negative current through the fault in order to keep the exposed surface of the conductor free from corrosion salts.

Protection of Houses, Ships or Buildings, Electric.—Means for protection from the destructive effects of a lightning discharge, consisting essentially in the use either of lightning-rods or of an enclosing conducting shell.

Protection of Metals, Electric.—The protection of a metal from corrosion by placing it in connection with another metal, which, when exposed to the corroding liquid, vapor or gas, will form with the surrounding liquid the positive element of a voltaic couple and will, therefore, alone be corroded.

Protection of Ship's Sheathing, Electric.—Attaching pieces of zinc to the copper sheathing of a ship for the purpose of preventing the corrosion of the copper by the water.

Protective Action.—(1) The electric protection of metals. (2) The protection of structures from lightning by lightning protectors.

Protective Sheath.—A device attached to a transformer or converter, consisting of a copper strip or plate connected to the earth and interposed between the primary and secondary windings, to prevent any connection from taking place between the high-potential primary and the low-potential secondary circuit.

Protective Throw.—A term proposed for the protection afforded by a magnetic field to paramagnetic metals exposed to chemical action.

Protoplasm.—Bioplasm.

Psychrometer.—A form of recording hygrometer.

Public Supply Instruments.—Electric meters designed for registering the current or energy supplied to a consumer.

Pull.—A contact-maker similar in general construction to a push-button, but operated by a pull instead of by a push.

Pull Contact.—Any contact that is effected by the movement of a pendant or pull.

Pulley.—A wheel placed on a shaft for the driving of the same by means of a belt.

Pull-Off.—(1) An insulator employed on curves to hold the trolley wire in proper position. (2) A steel wire attached to a trolley wire through an insulator, and employed to pull the trolley wire into position over a curve in the track.

Pull-Off Pole.—A pole provided for the suspension of a pull-off wire, or wires.

Pulsating Current.—A pulsatory current.

Pulsating Electromotive Force.—An electromotive force whose direction is pulsatory.

Pulsating Motor.—A motor employing a reciprocating movement in its armature as opposed to the ordinary rotary motion.

Pulsation.—(1) A quantity of the nature of an angular velocity, equal to 2π multiplied by the frequency of the oscillation, or to 2π divided by the duration of a single period. (2) In a simple-harmonic current circuit, the angular velocity of the corresponding circularly moving point.

Pulsation, Electric.—An electric pulse or oscillation.

Pulsation of Reactance.—Variations periodically occurring in the apparent reactance of an alternating-current circuit or machine.

Pulsation of Resistance.—Periodic variations in the apparent resistance of an alternating-current circuit or apparatus.

Pulsatory Continuous-Current.—A current whose direction remains constant, but whose intensity is subject to steady changes.

Pulsatory Electromotive Force.—An electromotive force whose value is subject to pulsatory changes.

Pulsatory Magnetic-Field.—A field whose strength pulsates in such a manner as to induce oscillatory currents in neighboring circuits.

Pulsatory Magnetism.—Magnetism produced by pulsatory currents.

Pulse, Electric.—(1) An electric oscillation. (2) A momentary flow of electricity through a conductor which gradually varies from zero value to the maximum, and then to zero value again, like a pulse or vibration in an elastic medium.

Pumping of Alternating-Current Dynamo.—A pulsation in the motion of a synchronously-running alternating-current generator or motor, due to imperfect synchronism.

Pumping of Electric Lights.—A term

- sometimes applied to a pulsatory or periodic increase or decrease in the brilliancy of lights.
- Punched - Clip Switch.**—A form of switch in which the clips are punched out of sheet metal.
- Puncher.**—In automatic telegraphy, a perforator.
- Punning of Telegraph Pole.**—The process of packing the earth around the base of a telegraph pole.
- Pupillary Photometer.**—A photometer whose operation is dependent on the diminution of the diameter of the pupil of the eye with the intensity of the light striking the eye.
- Pure Spectrum.**—A single spectrum or distribution of luminous frequencies as distinguished from a spectrum which is formed by the superposition of a number of spectra slightly displaced with reference to one another.
- Push.**—A term sometimes applied to a push button.
- Push Box.**—A box provided for the reception of the mechanism of a push button or push.
- Push Button.**—A device for closing an electric circuit by the movement of a button.
- Push-Button Rattler.**—(1) A device connected with a push-button to show that a bell connected at a distant point in the circuit of the button rings when the button is pressed. (2) A push-button combined with an electro-magnetic vibrator.
- Push-Button Socket.**—A socket provided with a push-button for the closing of a circuit.
- Push-Button Socket-Key.**—An incandescent lamp-socket so provided with a push-button key as to permit the lamp to be readily lighted or extinguished by the same hand that holds it.
- Push-Button Switch.**—A switch operated by a push-button.
- Push Contact.**—A name sometimes applied to a push button.
- Putting Straight.**—The operation of restoring the normal condition of wires which have been crossed at two way stations.
- Pyknometer.**—A term sometimes used for a specific gravity bottle, employed in determining the specific gravity of a liquid.
- Pyr.**—(1) A bougie-decimale. (2) A proposed unit of luminous intensity equal to the one-twentieth of the Violle standard. (3) A proposed name for the one-twentieth of the Violle standard.
- Pyrheliometer.**—An apparatus for measuring the energy of solar radiation.
- Pyro-Electric.**—Pertaining to pyro-electricity.
- Pyro-Electric Crystal.**—Any crystalline substance capable of producing pyro-electric phenomena on being unequally heated.
- Pyro-Electricity.**—Electricity produced in certain crystalline bodies by their unequal heating or cooling.
- Pyrogravure.**—A process for the decoration of wood, copper, or glass, by the burning action of an electrically or otherwise heated tool.
- Pyro-Magnetic.**—Of or pertaining to pyro-magnetism.
- Pyro-Magnetic Electric Device.**—Any device operated by or employing pyro-magnetism.
- Pyro-Magnetic Generator or Dynamo.**—An apparatus for producing electricity directly from the heat derived from burning fuel.
- Pyro-Magnetic Motor.**—A motor consisting of an armature formed of a disc or ring of thin steel, which is set in motion when unequally heated, by reason of the difference in the coercive force so produced.
- Pyro-Magnetism.**—A term sometimes applied to the phenomena of the combined effects of magnetism and heat.
- Pyrometer.**—An instrument for determining temperatures higher than those which can be readily measured by thermometers.
- Pyrometer, Electric.**—A device for determining the temperature of a body by the measurement of the electric resistance of a platinum wire exposed to the heat to be measured.
- Pyr-Steradian.**—(1) The flux of light corresponding to the luminous intensity of one pyr extending over the solid angle of one steradian. (2) A term sometimes used for lumen.

Q

Q or **q**.—A contraction for electric quantity.

Quad.—(1) A contraction for quadruplex telegraphy. (2) An abbreviation sometimes employed for the quadrant or the unit of self-inductance.

Quad-Meter.—(1) A secohm meter. (2) An instrument for measuring inductance.

Quadrant.—A term proposed for the earth quadrant or practical unit of self-induction, now officially recognized as the henry. (2) The length of the arc, from the pole to the equator, on a terrestrial meridian circle extending through Paris, or very nearly 10,000 kilometers.

Quadrant Electrometer.—An electrometer in which an electrostatic charge is measured by the attractive and repulsive force exerted by four plates or quadrants on a light needle of aluminium suspended between them.

Quadrantal Deviation of Mariner's Compass.—(1) The deviation of a magnetic needle due to the induced magnetism in the iron of a ship acting as a mass of soft iron, and not as a permanent magnet. (2) The deviation of a compass needle on board ship which changes sign once in each quadrant.

Quadrantal Error.—The quadrantal deviation of a mariner's compass as distinguished from either the semicircular or the heeling error.

Quadrature.—A term applied to express the fact that one simple-harmonic quantity lags 90° behind another.

Quadruplex Circuit.—A circuit employed in quadruplex telegraphy.

Quadruplex Connector.—Any connector suitable for connecting the four ends of four wires.

Quadripolar Dynamo or Generator.—A multipolar dynamo having four poles in its field frame, or four magnetic circuits through its armature.

Quadripolar Field.—A field produced by four separate magnet poles.

Quadruplex.—Of or pertaining to quadruplex telegraphy.

Quadruplex Balance.—The balance obtained in a quadruplex circuit in order to permit quadruplex transmission.

Quadruplex Circuit.—Any single circuit over which four separate messages can be simultaneously transmitted, two in one

direction and the remaining two in the opposite direction.

Quadruplex Telegraph.—A general term embracing the apparatus employed in quadruplex telegraphy.

Quadruplex Telegraphy.—A system for the simultaneous transmission of four messages over a single wire, two in one direction, and two in the opposite direction.

Quadruplex Telephony.—The simultaneous transmission of four telephonic messages, two in one direction and the remaining two in the opposite direction.

Quadruplex Transmission.—Telegraphic or telephonic transmission effected by means of a quadruplex system.

Quadruplex Working.—Operating a telegraph or telephone line by quadruplex apparatus.

Quadruplex Re-Entrant Armature Winding.—An armature provided with four independent conducting paths or windings, each of which is independently re-entrant.

Qualitative Analysis.—A chemical analysis which merely ascertains the kinds of elementary substances present.

Quality of Musical Sound.—(1) That property of a musical note which enables it to be distinguished from another which possesses the same wave length and amplitude; *i. e.*, the same pitch and loudness. (2) The timbre of sound.

Quality of Radiation.—The character of radiation in regard to the frequency and amplitude of the vibration it contains.

Quantitative Analysis.—Chemical analysis which ascertains the different proportions in which the component substances enter into a compound substance.

Quantity Armature.—An old term for an armature wound with a few coils and of comparatively low resistance.

Quantity Connection for Condensers.—A term formerly employed for the multiple connection of a number of condensers.

Quantity Current.—An old term for a current produced by a voltaic battery connected in multiple-arc.

Quantity Efficiency of Storage Battery.—(1) The ratio of the number of ampere-hours taken out of a storage bat-

- tery to the number of ampere-hours put in the battery in charging it. (2) The ampere-hour efficiency.
- Quantity, Electric.**—The amount of electricity present in any current or charge.
- Quantity Meter, Electric.**—A coulomb meter.
- Quantity of Light.**—(1) Flux of light. (2) The product of the luminous intensity and the solid angle through which it is emitted.
- Quantivalence.**—A general term for the combining capacity of the elements.
- Quarter-Load Efficiency of Transformer.**—The efficiency of a transformer at quarter-load.
- Quarter-Period.**—The time in which a vibrating body, or alternating quantity, completes one quarter of its cycle.
- Quarter-Phase.**—The condition of diphasic relationship or the separation of two alternating quantities by a quarter period.
- Quarter-Phase Armature.**—A polyphase armature which will produce quarter-phase currents.
- Quarter-Phase Armature-Winding.**—Such a winding of a polyphase armature as will permit it to produce quarter-phase currents.
- Quarter-Phase Bar-Winding for Armature.**—A form of bar winding employed in the armature of a quarter-phase generator.
- Quarter-Phase System.**—A two-phase system of alternating-current distribution employing two currents dephased by a quarter period.
- Quartz Fibre.**—A suspension fibre obtained by drawing a thread from a fused crystal of quartz.
- Quasi-Resonance.**—(1) Imperfect resonance. (2) The production of resonance in a primary alternating-current circuit by the adjustment of a secondary circuit or circuits.
- Quega.**—A prefix for a quintillion, or 10^{15} .
- Quegohm.**—A quintillion ohms, or a thousand million megohms.
- Quick.**—To cover with an adherent film of mercury.
- Quick-Break.**—A break of a circuit obtained by means of a quick-break switch.
- Quick-Break Switch.**—A switch by means of which a circuit may be rapidly broken.
- Quickened.**—A term employed in electroplating for a surface which has been provided for the reception of a deposit of silver by dipping the article in a quickening liquid.
- Quickening Liquid.**—A term sometimes applied to the quickening solution.
- Quickening Process.**—A process employed in quickening.
- Quickening Solution.**—A solution of a salt of mercury in which objects to be electro-plated are dipped after cleansing, just before being placed in a plating bath.
- Quicking.**—Subjecting to the quicking process.
- Quicking Solution.**—A quickening solution.
- Quiet Arc.**—A noiseless arc.
- Quiet Commutation.**—Commutation devoid of sparking.
- Quiet Discharge.**—A name given to a convective discharge in order to distinguish it from a noisy disruptive discharge.
- Quintuple Harmonic.**—A harmonic of five times the frequency of the fundamental.
- Quivering of Magnetic Field.**—The pulsation of magnetic flux either under the leading pole-piece of a generator, or the trailing pole-piece of a motor, due to the successive commutations of the advancing armature coils.

R

- R.**—A contraction for ohmic resistance.
- R.**—A symbol proposed for magnetic resistance or reluctance.
- r.**—A symbol for radius.
- ρ .—A symbol for specific electric resistance or resistivity.
- R. M. S. Current.**—(1) A term proposed for the square root of the mean square of the current. (2) The effective current.
- R. P. M.**—An abbreviation for revolutions per minute.
- R. Q.**—In submarine telegraphy, a request for repetition of a doubtful word, phrase, or sentence.
- Raad.**—A name formerly given by the Arabians to the torpedo or electric ray.

Raceway.—A continuous space provided in a conduit for the insertion or removal of a conductor or conductors.

Racing of Dynamo.—A general term for any excessive speed produced in a dynamo-electric machine by the sudden removal of its load, as by the breaking of a belt.

Racing of Motor.—An increase in the speed of an electric motor when the load is suddenly removed.

Rack-Rail-Incline Electric Railway.—A means adopted for the passage of a trolley or other car over a steep grade by the use of a rack rail to be operated by the ordinary incline system where the line is too long.

Racking of Armature Conductors.—A term sometimes applied to a sudden drag exerted on the armature conductors of a dynamo or motor during operation.

Rad.—(1) A unit quantity of time-flux of light. (2) A lumen-second or one lumen, maintained during one second. (3) A name proposed for the lumen-second.

Radial Armature.—A term sometimes used for pole armature.

Radial Current.—A term proposed for a current which radiates from a centre.

Radial Photometer.—A photometer whose bench is movable about a vertical axis, so as to be readily turned into any azimuth, and employed to determine the intensity of the light emitted by a luminous source in various directions.

Radial Truck.—A triple-truck support for a car-body, in which the car is supported on the centres of the end trucks in such a manner that they may swivel freely, carrying the middle truck between them.

Radially-Laminated Armature.—An armature core whose iron consists of thin discs suitably supported on the shaft.

Radian.—(1) A unit angle. (2) An angle whose circular arc is equal in length to its radius; or, approximately, $57^{\circ} 17' 45''$.

Radian-per-Second.—A unit of angular velocity of a rotating body.

Radiant Efficiency.—The ratio of the light-giving radiation to the total radiation.

Radiant Energy.—Energy transferred or charged on the universal ether.

Radiant Matter.—(1) That condition of the gaseous matter that constitutes the residual atmosphere of high vacua. (2) Ultra-gaseous matter.

Radiant Vector.—A vector point-function which represents the rate and direc-

tion at and in which energy is being transferred in space.

Radiophonic Transmission.—(1) Transmission by means of a photophone. (2) Transmission of articulate speech along rays of light.

Radiate.—(1) To transfer energy by means of waves. (2) To issue radially, or by rectilinear divergence, from a common centre.

Radiating.—(1) Transferring energy by means of waves. (2) Issuing radially.

Radiation.—(1) A transference of energy by means of waves. (2) Issuing radially from a common centre.

Radiation Constant.—The amount of heat lost by radiation in unit time when the temperature of the radiating body is one degree of the thermometric scale above that of the surrounding air.

Radiation, Electric.—(1) The transference of electric energy by means of electro-magnetic waves set up in the surrounding ether. (2) That property of a rapidly oscillating or alternating-current circuit by virtue of which energy is expended by the circuit in the form of electro-magnetic waves.

Radiation Meter.—(1) An instrument for measuring radiation. (2) A meter employed for the measurement of the radiation emitted by an electric oscillation, whose operation is dependent on the elongation produced in a stretched wire by the heat developed therein by currents induced by the rapidly oscillating field of force.

Radiation of Electricity.—The radiation of electric energy by means of electro-magnetic waves.

Radiation of Magnetic Flux.—(1) The passage of magnetic flux out of the north-seeking pole of a magnet or solenoid. (2) The issue of magnetic flux from a magnetic pole in approximately radial paths.

Radiator, Electric.—(1) An electric heater so placed as to radiate its heat into a room or other space to be heated. (2) An electric circuit which radiates or produces electro-magnetic oscillations or waves.

Radicals.—(1) Unsaturated atoms or groups of atoms, in which one or more of the bonds are left open or free. (2) Ions.

Radiograph.—The word now generally employed for a picture taken by means of X-rays.

Radiography.—(1) The process of taking radiographs, or X-ray pictures. (2) X-ray photography.

- Radiometer.**—(1) A word frequently employed for the Crookes radiometer. (2) An instrument in which the rotation of a light set of vanes is produced in an ultragaseous space, by radiant energy.
- Radio-Micrometer.**—An electric apparatus for measuring the intensity of radiant heat.
- Radiophone.**—A name sometimes given to a photophone.
- Radiophonic.**—Of or pertaining to the radiophone.
- Radiophonic Sounds.**—Sounds resulting from the direct action of radiation on certain bodies.
- Radiophony.**—The production of sound by a body capable of absorbing radiant energy, when an intermittent beam of heat or light falls on it.
- Radius of Gyration.**—In a rotating body, a radial distance from the centre of rotation at which, if the entire mass of the body were collected, its moment of inertia would remain the same.
- Rail-Bond, Electric.**—Any device whereby the ends of contiguous rails are placed in good electrical contact with one another, so that the resistance of the rails, employed as a portion of the return-circuit, may be as small as possible.
- Rail Bonding.**—Connecting rails by electric bonds, for the purpose of effecting intimate electric contact between them.
- Rail Joint.**—A rail bond.
- Railroad, Electric.**—A railroad or railway on which the cars are driven or propelled by means of electric motors placed on the cars, or on locomotives.
- Railroad Switchboard.**—A switchboard employed in a railroad power-house, to which the generator and feeder terminals are attached.
- Railway Circuit.**—A circuit for operating an electric railway.
- Railway Current-Controller.**—(1) A term formerly given to a form of switchboard employed for controlling the output of an electric power-house. (2) A railroad motor-controller for starting and stopping the cars, and for varying their speed.
- Railway, Electric.**—An electric railroad.
- Railway Generator.**—A dynamo-electric machine which develops the current employed in systems of electric railways.
- Railway Line-Crossing.**—(1) Means provided for supporting the separate trolley wires at places where two or more wires cross one another. (2) A trolley crossing.
- Railway Line-Section.**—One of the independent divisions into which the trolley wire and its feeder system are divided by means of section insulators, for the purpose of preventing an accidental ground at one point from interrupting the traffic over a considerable portion of the road.
- Railway Motor.**—An electric motor employed for the propulsion of an electric street or trolley car.
- Railway Power-Generator.**—A term sometimes used for railway generator.
- Railway Return Circuit.**—(1) A term frequently employed for the ground-return of a trolley system. (2) The return circuit, generally a grounded circuit, employed in trolley systems.
- Railway Return-Wire.**—(1) A copper wire employed for the purpose of aiding and re-inforcing the ground-return, so as to decrease the wasteful expenditure of energy due to the poor quality of the rail and track, with its numerous joints, as a conductor. (2) A term sometimes employed for a railway return-circuit.
- Railway Section-Insulators.**—Insulators employed for the purpose of dividing the trolley wire or line into a number of independent sections.
- Railway Turn-Out.**—(1) In a single-track road, an extra track provided to permit the passage of a car in the opposite direction. (2) A local section of track into which a car can be run, so as to leave the main line clear.
- Range Finder, Electric.**—Fiske's electric range finder.
- Range Indicating System.**—On warships a telegraphic indicating-system for announcing, at any or all of the guns, the range or distance of the target as signalled from the range finder.
- Ratchet-Pendant Argand Electric Gas-Burner.**—A ratchet-pendant electric burner adapted for lighting an Argand gas burner.
- Ratchet-Pendant Electric Gas-Burner.**—A gas burner in which one pull on a pendant turns on the gas and ignites it by means of an electric spark from a spark coil, and the next pull turns it off.
- Ratchet-Pendant Electric Candle Burner.**—A pendant for both lighting and extinguishing a candle gas-jet.
- Rate-of-Doing-Work.**—(1) Activity. (2) Power.
- Rated Candle-Power.**—A nominal candle-power.
- Ratio Arms of Bridge.**—A name some-

- times given to the proportionate arms of a bridge.
- Ratio of Conversion.**—A term sometimes employed instead of ratio of transformation.
- Ratio of Transformation.**—The ratio between the electromotive force produced at the secondary terminals of an induction coil, or transformer, and the electromotive force impressed on the primary terminals.
- Ray.**—(1) A term sometimes employed for a single line of light or other form of radiant energy, as distinguished from a pencil of rays or a beam. (2) A line of radiant energy flux.
- Ray, Electric.**—(1) A species of fish which possesses the power of producing electricity. (2) A single line of electric flux-energy.
- Rayleigh's Current-Weigher.**—A form of electro-dynamometer balance.
- Rayleigh's Form of Clark's Standard Voltaic Cell.**—A modified form of Clark's standard voltaic cell.
- Reactance.**—(1) The inductance of a coil or circuit multiplied by the angular velocity of the sinusoidal current passing through it. (2) A quantity whose square added to the square of the resistance gives the square of the impedance, in a simple-harmonic current circuit.
- Reactance Factor.**—The ratio of the reactance of a coil, conductor, or circuit, to its ohmic resistance.
- Reactance of Condenser.**—(1) The reciprocal of the product of the capacity of a condenser, and the angular velocity of the simple-harmonic pressure with which it may be connected. (2) A quantity which divided into the alternating-current pressure at condenser terminals, gives the current strength in the condenser.
- Reactance of Mutual Inductance.**—In an alternating-current circuit, the product of a mutual inductance and the angular velocity.
- Reacting Inductive Electromotive Force of Primary Circuit.**—(1) The C. E. M. F. of self-induction in a primary alternating-current circuit. (2) The C. E. M. F. of mutual-induction in a primary alternating-current circuit, or the C. E. M. F. due to current in the secondary circuit.
- Reaction.**—In electro-therapeutics, muscular contractions following the closing or opening of an electric circuit through the nerves or muscles.
- Reaction Coil.**—(1) A magnetizing coil surrounded by a conducting covering or sheathing which opposes the passage of rapidly alternating currents less when directly over the magnetizing coil than when a short distance from it. (2) A choking coil.
- Reaction Machine.**—An induction machine.
- Reaction Motor.**—An induction motor.
- Reaction of Degeneration.**—An alteration in the behavior of nerves and muscles under electric stimulation, due to disease.
- Reaction of Exhaustion.**—A condition of nervous or muscular irritability to electric excitation, when a certain reaction produced by a given current strength cannot be reproduced without an increase in current strength.
- Reaction Principle of Dynamo-Electric Machine.**—The mutual interaction between the current generated in the armature coils and the field coils of a continuous-current dynamo-electric machine, each strengthening the other until the full-working current which the machine is capable of developing is produced.
- Reaction Telephone.**—An electro-magnetic telephone in which the currents induced in a coil of fine wire attached to the diaphragm are passed through the coils of an electro-magnet, each thus reacting on and strengthening the other.
- Reaction Time.**—The time required for the effects of an electric current to pass from a nerve to a muscle.
- Reaction-Wheel, Electric.**—A wheel driven by the reaction of a convective discharge.
- Reactive Circuit.**—A circuit containing either inductance or capacity alone, or both inductance and capacity.
- Reactive Coil.**—A reaction coil.
- Reactive Drop.**—The drop in a circuit or conductor due to its reactance, as distinguished from the drop due to its ohmic resistance.
- Reactive Effect.**—The choking effect of reactance in an alternating-current circuit.
- Reactive Electromotive Force.**—In an alternating-current circuit, that component of the electromotive force that is in quadrature with the current and is employed in balancing the C. E. M. F. of inductance.
- Reading Microscope.**—A form of microscope employed for the measurement of very small distances.
- Reading Telescope.**—A telescope em-

- ployed in electric measurements for reading the deflections of a galvanometer.
- Real Cable.**—In duplex submarine cable-telegraphy the actual cable, as distinguished from the artificial cable.
- Real Efficiency of Storage Battery.**—(1) The ratio of the number of watt-hours taken out of a storage battery to the number of watt-hours put into the battery in charging it. (2) The energy efficiency, or watt-hour efficiency, of a storage battery, as distinguished from its quantity efficiency, or ampere-hour efficiency.
- Real Hall Effect.**—A transverse electromotive force produced by magnetic flux through conductors conveying electric currents in a manner somewhat similar to that in which the Faraday effect is produced.
- Real Image.**—(1) An image formed by rays of light that actually meet in the various visible points, as distinguished from a virtual image. (2) An image which is capable of being received on a screen.
- Rebabbitting.**—The operation of replacing the Babbitt metal in the bearings of a machine.
- Recalescence.**—A property possessed by a bar or a mass of cooling incandescent steel, of again becoming incandescent after having cooled sufficiently to no longer emit luminous heat.
- Recalibration.**—A new calibration of an instrument.
- Received Current.**—A term used in telegraphy to distinguish the currents that come in over a line from a distant station, from those that are sent out to a distant station.
- Receiver.**—A name sometimes given to a receiving instrument of a gramophone, graphophone, telephone, or telegraph instrument.
- Receiver Magnet.**—A receiving magnet.
- Receiving End of Line.**—That end of a line at which the currents arrive, as distinguished from the end at which they are sent out.
- Receiving Leg of Telegraphic Loop.** The wire of a telegraphic loop upon which messages are received, as distinguished from the sending leg.
- Receiving Magnet.**—(1) A name sometimes given to the relay of a telegraphic system. (2) In general, any magnet used directly in the receiving apparatus at the receiving end of a telegraph or telephone line.
- Receiving Signaller.**—(1) A receiving operator. (2) An operator engaged in receiving a telegraphic message.
- Receiving Transformer.**—A transformer at the receiving end of a circuit.
- Receptacle.**—In incandescent lighting a permanent device for receiving an attachment plug.
- Receptive Device.**—(1) A translating device. (2) In electrotechnics, a magnet or electro-receptive device. (3) A device for receiving energy and utilizing or transforming it.
- Reciprocal.**—The quotient arising from dividing any quantity into unity.
- Reciprocating Motor.**—A motor with a reciprocating action, or with a motion alternately in opposite directions, as distinguished from a rotary motor.
- Reciprocal Vectors.**—Two vectors whose product is equal to the numeric unity.
- Recoil Circuit.**—A term sometimes applied to the circuit that lies in the alternative path of a discharge.
- Recoil Kick of Disruptive Discharge.** A kick or reaction produced by a disruptive discharge.
- Recorder.**—A word sometimes used for either a telegraphic recorder, or a siphon recorder.
- Recorder Ammeter.**—An ammeter whose indications are permanently recorded.
- Recorder Battery.**—The local battery supplying the magnets, or mouse-mill, of a siphon recorder.
- Recorder Circuit.**—The circuit of a siphon recorder.
- Recorder Coil.**—The receiving coil of a siphon recorder.
- Recorder Magnets.**—The magnets which supply the magnetic flux in which moves the receiving coil of a siphon recorder.
- Recorder Shunt.**—A shunt of low resistance placed across the terminals of the coil of a siphon-recorder during sending.
- Recorder Signals.**—Signals received on a siphon recorder by the projection of ink upon a moving strip of paper from a small glass siphon connected with the receiving coil.
- Recorder Slip.**—The strip of paper recording, or prepared for recording, siphon-recorder signals.
- Recorder Switch.**—The switch employed in connection with a siphon recorder for changing from sending to receiving connections.
- Recorder - Vibrator.**—An electrome-

- chanical vibrator for forcing an intermittent flow of ink from the siphon of a recorder on to a band of paper moving beneath it.
- Recording Compass.**—A compass so arranged as to record the directions of the needle, and to sound an alarm in case the course of the vessel deviates any predetermined number of degrees.
- Recording Drum.**—A cylindrical drum covered by a sheet or strip of paper on which a chronographic or other record is made.
- Recording Meter.**—Any form of electric meter that records its indications.
- Recording Voltmeter.**—A voltmeter whose indications are permanently recorded.
- Recording Wattmeter.**—(1) A recording form of wattmeter. (2) A dial watt-hour or kilowatt-hour meter.
- "Recovery" of Condenser.**—The condition of a condenser whose dielectric has regained its neutral condition after having been strained by a charge.
- Rectal Electrode.**—An electrode suitable for the treatment of the rectum.
- Rectangular Curve.**—A curve whose outline approximates or conforms to a rectangular shape.
- Rectangular Type of Periodically Alternating Electromotive Force.**—An electromotive force whose variations of strength are represented by a curve of rectangular outline.
- Rectangular Variation - Diagram.**—A diagram drawn to rectangular co-ordinates, and representing the variation of any quantity or quantities.
- Rectification of Alcohol, Electric.**—A process whereby the bad taste and odor of alcohol, due to the presence of aldehydes, are removed by the electrical conversion of the aldehydes into true alcohol through the addition of hydrogen atoms.
- Rectified.**—Commutated, or caused to take one and the same direction.
- Rectified Currents.**—Commutated currents.
- Rectifier.**—A name sometimes given to a commutator.
- Rectilinear Co-Ordinates.**—Co-ordinates measured from two rectilinear axes intersecting in the plane of delineation at a point called the origin.
- Rectilinear Current.**—A current flowing through a straight or rectilinear portion of a circuit.
- Rectifying Commutator.**—A term sometimes applied to a commutator which commutes alternating into direct currents.
- Red Candle.**—A photometric candle employed in connection with a red glass screen, for the purpose of enabling the unpracticed eye to more readily compare it with the source whose intensity is to be measured.
- Red Heat.**—The temperature at which a body begins to glow or to emit red rays of light.
- Red Hot.**—Possessing the temperature of red heat.
- "Red" Magnetism.**—A name formerly applied to the magnetism at the north pole of a magnet, as distinguished from the so-called "blue" magnetism at the south pole.
- Redressed.**—A word sometimes employed for commuted.
- Redressed Currents.**—Commutated currents.
- Reduced Battery.**—A portion only of a main-line battery employed in quadruplex telegraphy.
- Reduced Deflection Method.**—A method of measuring electromotive force, resistance or current, by determinations based upon an observed reduction in current strength, and resulting deflection of a galvanometer in the circuit.
- Reducing Clamp for Underground Tubing.**—A clamp at a coupling box clasping an underground tube, of such dimensions as to permit of a change in the diameter of the next succeeding tube.
- Reducing Coupling.**—A flexible coupling connecting two conductors of different diameters.
- Reducing Switch.**—A switch so connected with a circuit as to bring a reduced or lowered pressure upon a sub-circuit.
- Reducteur Resistance for Volt-Meter.**
(1) A coil of known resistance as compared with the resistance of the coils of a voltmeter, that is connected with them in series for the purpose of increasing the range of the instrument. (2) A multiplying coil, or multiplier of a voltmeter.
- Reducteur Shunt for Ammeter.**—(1) A shunt coil connected in multiple with the coils of an ammeter for the purpose of changing the value of its readings. (2) A multiplier.
- Reduction Factor of Galvanometer.**—The ratio between the horizontal intensity of the field of a galvanometer and the galvanometer constant.

- Reduction Gear.**—Gear employed on a street-car for suitably reducing the speed of the car below that of the motor which drives it.
- Reed Interrupter.**—A form of automatic make-and-break contact, operated by the vibrations of a reed.
- Reel Insulator.**—An insulator resembling a reel in shape, and suitable for use in connection with an engine plane signal system.
- Re-Enforcement of Sound.**—An increase in the intensity of sound by the use of sounding boards, resonators, or reflectors.
- Re-Entrancy.**—The intersection of a curve by itself.
- Re-Entrancy of Armature Winding.**—The condition or property of an armature winding, by virtue of which the conducting path through the armature repeats itself or re-enters itself.
- Re-Entrant Armature-Windings.**—Armature windings, which, when followed in either direction, lead back to the starting point.
- Refining, Electric.**—The refining of metals by the application of electrolysis.
- Reflect.**—To throw off from a surface according to the laws of reflection, as of waves in an elastic medium.
- Reflecting.**—Throwing off from a surface in accordance with the laws of reflection.
- Reflecting Galvanometer.**—A term sometimes applied to a mirror galvanometer.
- Reflection.**—The throwing back of a body or wave from a surface at an angle equal to that at which it strikes the surface.
- Reflection of Electro-Magnetic Waves.**—The reflection of electro-magnetic waves that occurs from the surfaces of certain substances placed in the path of the waves.
- Reflector.**—A reflecting surface suitably shaped to reflect rays of light in any desired direction.
- Reflector Bracket.**—A bracket for supporting two insulators and for holding the support of a street lamp, with or without a reflector.
- Reflector Search-Light.**—A search-light consisting of a focussing lamp placed at the focus of a suitable reflector.
- Reflector Shade.**—A shade surrounding an arc-lamp, a portion of whose surface is covered with reflecting material.
- Refract.**—To change the direction of waves in any elastic media in accordance with the laws of refraction.
- Refracting.**—Changing the direction of waves in elastic media in accordance with the laws of refraction.
- Refraction.**—The bending of a ray of light, heat, or electro-magnetism, at the interface of any two transparent media, whose elasticity and density differ.
- Refractive Energy.**—A value equal to the index of refraction minus unity.
- Refractory.**—(1) Possessing the power of resisting fusion by heat. (2) Fusible only at extraordinarily high temperatures.
- Refreshing Action of Current.**—The restoration, after fatigue, of muscular and nervous excitability obtained by the action of voltaic alternatives.
- Regenerable Cell.**—A regenerative cell.
- Regenerated Cell.**—A cell which has had its ability for producing current restored by a charging process.
- Regenerative Armature.**—A word proposed for the armature of a dynamo that is capable of producing its own magnetic field-flux, when commuted with a backward lead.
- Regenerative Cell.**—(1) A name sometimes given to an early form of storage cell. (2) Any cell which can have its energy restored by the action of a charging current.
- Regional Magnetic Disturbances.**—A term proposed for magnetic disturbances that are apparently confined to limited regions of the earth's surface.
- Register.**—A word frequently employed for any registering apparatus.
- Registering Apparatus, Electric.**—Devices for obtaining permanent records by electrical means.
- Registering Declination-Magnetometer.**—A magnetometer employed for automatically registering the magnetic declination.
- Registering Electrometer.**—An electrometer whose indications are automatically registered.
- Registering Photometer.**—(1) A photometer which registers not the photometric but the actinic or chemical action of light. (2) A recording photometer.
- Regulating Box.**—(1) A rheostat inserted in the field circuit of a generator or motor for regulating the current passing through the field-magnet coils. (2) A rheostat.
- Regulating Cell for Storage Battery.**—A counter-electromotive force cell.
- Regulating Lamp-Socket.**—(1) A lamp socket containing a device controlled by

- a key or switch for regulating the degree of incandescence of the filament. (2) A general term for any form of lamp socket which will permit the light to be economically turned down or lowered in intensity.
- Regulating Wires.**—Adjusting the tension of overhead line wires.
- Regulation of Dynamo.**—Such an adjustment of a dynamo as will preserve constant either its current or its pressure.
- Regulation of Motor.**—Such an adjustment of a motor as will preserve constant its speed, or its torque, or both.
- Regulator for Dynamo.**—Any device by means of which the regulation of a dynamo is effected.
- Regulator for Motor.**—Any device by means of which the regulation of a motor is effected.
- Regulator Magnet.**—(1) A magnet whose function is to automatically effect any desired regulation. (2) In a system of automatic constant-current dynamo-regulation, the magnet by the movements of whose armature the commutator brushes are automatically shifted to such positions on the commutator as will maintain the current practically constant, despite changes in the resistance of the circuit external to the machine.
- Reguline Electro-Metallurgical Deposit.**—A flexible, adherent and strongly coherent film of electrolytically deposited metal.
- Rejuvenation of Luminescence.**—Reimparting, by exposure to light or other suitable means, the power of luminescence to a substance after it has lost this power.
- Relative Inductivity.**—The ratio of the inductivity of a medium to the inductivity of vacuum.
- Relative Permittivity.**—The ratio of the permittivity of a medium to the permittivity of vacuum.
- Relaxation Distance.**—The distance in which an electro-magnetic wave traveling along the surface of a conductor, diminishes in amplitude in a ratio whose Napierian logarithm is unity.
- Relaxation Time.**—The time during which a logarithmically diminishing quantity diminishes in a ratio whose Napierian logarithm is unity.
- Relay.**—In telegraphy, an electro-magnet provided with contact points placed on a delicately supported armature, the movements of which open or close a local receiver circuit.
- Relay Bell.**—An electric bell in which a relay magnet is employed to switch a local battery into the circuit of the bell.
- Relay Contact.**—(1) A term frequently applied to a form of electro-magnetic instrument by means of which a local circuit is completed on the passage of a current. (2) The contact point of a relay.
- Relay Magnet.**—(1) A term sometimes given to a relay. (2) The permanent magnet of a polarized relay. (3) The electro-magnet of a relay.
- Relief Lamp.**—(1) An incandescent lamp whose socket is provided with a spring cut-out, so arranged that on the breaking of the lamp the circuit is automatically closed. (2) An incandescent lamp held in reserve for insertion in a series system to take the place of a lamp that has been cut out.
- Relief Operators.**—In telegraphy or telephony, operators coming on duty to relieve the operators at work.
- Relief Photometer.**—The name given to a class of photometers in which the two divisions of the screen are not placed in the same plane but at right angles to each other, the quality of the illumination being readily determined since the whole screen then appears as a single plane illuminated surface, in which the edge of a dihedral angle of the screen is no longer perceptible.
- Relievo.**—(1) The opposite of intaglio. (2) A stone, electro, or other solid body, in which a figure is so represented that its outlines project or stand out from the surface.
- Reluctance.**—(1) A term applied to magnetic resistance. (2) In a magnetic circuit the ratio of the M. M. F. to the total magnetic flux.
- Reluctancy.**—A term proposed for reluctance.
- Reluctivity.**—The specific magnetic resistance of a medium.
- Reluctivity Constants.**—The constants which, when applied according to a formula to the magnetic force or magnetic flux density in iron or steel, give the reluctivity of the iron or steel.
- Remaining Sockets.**—The sockets of a multiple telephone switchboard in circuit with any particular socket.
- Remanence.**—(1) Magnetic retentivity. (2) The property of magnetic substances to retain part of their magnetism owing to hysteresis. (3) The magnetic flux

density in a magnetic substance when the magnetic force is reduced to zero.

Remanent Flux.—Remanent magnetism.

Remanent Magnetism.—A phrase sometimes used in place of residual magnetism.

Remanent Polarization.—(1) A term proposed to describe the condition of a voltmeter when a certain number of discharges having traversed it, all in the same direction, and a series of discharges exactly equal to the preceding have been established in the opposite direction, the currents of polarization are less intense in the second than in the first. (2) Residual polarization of immersed electrodes after a passage of the current.

Removable Key-Switch.—A plug switch.

Removable Pole-Step.—A pole step capable of being inserted into and removed from a socket for the equipment of a lineman, to enable a lineman to reach the permanent steps.

Renovation of Secondary or Storage Cell.—The recharging of a run-down or discharged storage cell.

Renter.—A term sometimes used for subscriber.

Reophore.—A rheophore.

Repair-Wagon for Trolley Line.—A wagon provided with a tower or telescopic support employed for the repair of trolley lines.

Repeater.—The name sometimes given to a telegraphic repeater, or translator.

Repeating Relay.—(1) A relay employed in a repeater. (2) The relay in a telegraph circuit which repeats the signals into another circuit.

Repeating Sounder.—A telegraphic sounder which repeats a telegraphic despatch into another circuit.

Repeating Telegraphic Station.—A station situated at some intermediate point on a long telegraphic line which is divided into sections, where the currents received on one section are passed through a repeater by means of which they are sent on or repeated into the other section.

Repeating Telephone Coil.—An induction coil provided with two windings, usually of an equal number of turns, each winding being connected to a telephone circuit, so that the two circuits are placed in intimate inductive association.

Replenisher.—A static influence machine employed for charging a quadrant electrometer or other electrostatic device.

Repulsion, Electric.—The mutual driving apart, or tendency to mutually drive apart, which exists between two similarly charged bodies, or between two similar electric charges.

Repulsion Electrometer.—An electrometer in which the differences of potential are measured by means of the repulsion existing between two similarly charged bodies.

Repulsion Motor.—(1) An electric motor deriving its power from the repulsion between electric charges. (2) An alternating-current motor deriving its power from the repulsion between electric currents. (3) An alternating-current motor in which the armature is provided with temporarily short-circuited windings by means of a commutator and brushes.

Reserve-Cell Switch.—A switch employed in a storage-battery installation for the purpose of maintaining the pressure of discharge by introducing reserve cells into the circuit.

Residual Atmosphere.—The traces of air or other gas remaining in a space which has been nearly exhausted of its gaseous contents by a pump or other means.

Residual Charge.—The charge remaining in a Leyden jar after it has been disruptively discharged.

Residual Flux.—Residual magnetic flux.

Residual Magnetic-Flux.—(1) Remanence. (2) Magnetic flux remaining in a magnetic circuit by virtue of hysteresis after the withdrawal of the magnetizing force.

Residual Magnetism.—(1) The magnetism remaining in a core of an electromagnet on the opening of the magnetizing circuit. (2) The small amount of magnetism retained by soft iron when removed from any magnetic flux.

Residue, Electric.—A term proposed for residual charge.

Resilience.—(1) A word sometimes employed for elasticity. (2) The work done in deforming a bar up to the elastic limit.

Resin.—A general term applied to a variety of dried juices of vegetable origin.

Resinous Electricity.—A term formerly employed in place of negative electricity.

Resinous Electrification.—A name formerly applied to an electrification produced in resin by its friction.

- Resistance.**—(1) A word sometimes used for electric resistance. (2) Obstruction to flow. (3) Obstruction to force.
- Resistance Balance.**—A duplex or quadruplex balance adjusted for the resistance of a line by means of a rheostat.
- Resistance Balance of Duplex System.**
 (1) A balance obtained in a duplex system by inserting in the artificial line a resistance corresponding to that of the sum of the resistances of the main-line wire, the distant relays, and the distant battery.
 (2) A balance of resistance in duplex telegraphy as opposed to a balance of capacity.
- Resistance Board.**—A general term for a board on which resistances are so placed as to be capable of ready adjustment, connection, introduction, or removal from a circuit.
- Resistance Box.**—A term employed for a box containing graduated resistance coils.
- Resistance Bridge.**—A name frequently employed for a Wheatstone's resistance balance.
- Resistance Bridge-Box.**—A box form of Wheatstone's bridge.
- Resistance Coefficient.**—The resistance factor.
- Resistance Coil.**—(1) A coil of wire, strip, or conductor, possessing electric resistance. (2) A coil of wire, of known electric resistance, employed for measuring an unknown electric resistance.
- Resistance Column.**—A name given to a particular form of resistance coil or rheostat.
- Resistance Conductivity.**—The resistance offered by a substance to electric conduction, or to the passage of electricity through its mass.
- Resistance, Electric.**—(1) The ratio between the electromotive force of a circuit and the current that passes therein. (2) The reciprocal of electric conductance.
- Resistance Factor.**—The coefficient of frictional resistance to the movements of a suspended or oscillatory system.
- Resistance Losses.**—(1) Losses in any system for the transmission or the transference of energy occasioned by friction. (2) Losses in an electrical distribution system due to resistance.
- Resistance of Human Body, Electric.**
 The ohmic resistance which the human body offers to the passage of an electric discharge or current.
- Resistance of Human Skin, Electric.**
 The ohmic resistance of the skin.
- Resistance of Liquid, Electric.**—The ohmic resistance of a mass of liquid.
- Resistance of Telegraphic Leak.**—The resistance offered by a leak in a telegraphic line or circuit.
- Resistance of Voltaic Arc.**—Resistance offered by a voltaic arc to the passage of a current.
- Resistance Slide.**—(1) A rheostat in which the separate resistances or coils are placed in or removed from a circuit by means of a sliding contact or key. (2) Apparatus employed in telegraphy for charging a conductor to a given fraction of the maximum potential of a battery, so as to adjust its charge in order to balance the varying charge of the cable. (3) A set of coils by which a potential difference applied to the terminals is virtually divided into 10,000 parts, so that any ratio may be instantly selected.
- Resistance Thermometer, Electric.**—A thermometer whose indications are based on the change in the electric resistance of a metallic substance with changes of temperature.
- Resistance to Shearing.**—The quotient of the shearing stress by the shear produced.
- Resistants.**—Bodies possessing the power of resistance.
- Resister.**—A name sometimes given to a float or buoy connected with a cable while it is being paid out, in order to diminish the risk of injury from tension.
- Resisting Torque.**—(1) The torque which it is necessary to give to a motor in order to enable it to move. (2) The torque of retarding or opposing forces.
- Resistive.**—(1) Possessing the property of resistance. (2) Offering resistance.
- Resistivity.**—(1) The specific resistance of a substance referred to the resistance of a cube of unit volume. (2) Specific resistance, or the inverse of specific conductivity. (3) A quantity in the C. G. S. electro-magnetic system represented dimensionally in square centimetres per second.
- Resolution of Force.**—The separation of a single force acting with a given intensity in a given direction, into a number of separate forces acting in other directions.
- Resonance.**—(1) In a simple-harmonic current, circuit, or branch, containing both inductance and capacity, the neutralization or annulment of inductance-reactance by capacity-reactance, whereby the impedance of the circuit or branch is reduced to the ohmic resistance. (2) In an alternat-

ing-current circuit, or branch, containing localized inductance and capacity, the reinforcement of condenser pressure, inductance pressure, or current strength, due to the mutual neutralization or opposition of inductance and capacity-reactances. (3) In an alternating-current circuit, or branch, the attunement of a circuit containing a condenser to the same natural undamped frequency of oscillation as the frequency of impressed E. M. F. whereby the circuit responds to this frequency more than to any other. (4) In an alternating-current circuit, or branch, the annullment of inductance-reactance by capacity-reactance, whereby the impedance of the circuit or branch is not only reduced to its ohmic resistance, but its current is in phase with its impressed E. M. F. (5) In a secondary alternating-current circuit containing localized inductance and reactance, the attunement of the natural undamped frequency of oscillation to the frequency of the pressure impressed upon the primary circuit, whereby the secondary impedance is reduced to its ohmic resistance, the secondary current is a maximum for any given primary current strength, and the secondary current is in phase with the induced secondary E. M. F.

Resonant Capacity.—The capacity of a resonant circuit, or such a capacity as will render an alternating-current circuit resonant.

Resonant Circuit.—(1) A circuit whose dimensions are such as to bring it into resonance with a neighboring circuit. (2) A circuit containing distributed inductance and capacity, in which resonant effects are thereby produced.

Resonant Inductance.—The inductance of a resonant circuit, or the inductance which will render it resonant.

Resonant Rise of Potential.—A rise of potential in a circuit due to its resonance.

Resonator, Electric.—(1) An open-circuited conductor whose dimensions are such that electro-magnetic waves or pulses are propagated through it at the same rate as they are taking place in a neighboring circuit, and which, consequently, has electro-magnetic pulses set up sympathetically in it by resonance. (2) A circuit tuned to oscillate in synchronism with another oscillating or alternating circuit.

Rest.—(1) Freedom from motion. (2) The condition of a body in which it maintains an unchanged relative position with respect to neighboring bodies.

Restoring-Coil Battery.—In a telephone exchange the battery which operates the self-restoring annunciators.

Restoring-Coil Circuit.—In a telephone switchboard, the local circuit of the coil of a self-restoring annunciator.

Restored Cell.—A charged storage cell.

Resultant.—In mechanics, a single force that represents in direction and intensity the effects of two or more separate forces.

Resultant Fault.—The apparent position and magnitude of a fault in a cable due to the resultant of all its leakage, or faults compounded by the rules of parallel forces, or as represented by finding the centre of gravity of an unequally loaded rod.

Resultant Induction.—The magnetic induction in an armature of a dynamo or other magnetized body which is the resultant of several components of magnetic induction.

Resultant Magnetic Field.—A single magnetic field produced by two or more co-existing magnetic fields.

Resultant Magnetic Field of Dynamo.—The magnetic field which is the result of both the field due to the field magnets and to the current passing through the armature coils.

Resultant Magnetic Pole.—A term sometimes employed for a consequent pole.

Resultant Reactance.—The total reactance in a circuit or conductor.

Resuscitating Power of Secondary or Storage Cell.—The ability possessed by a storage cell to regain its normal condition under the influence of the charging current.

Retardance.—In a telephone circuit, a quantity alleged to represent the limitation of the circuit in regard to the transmission of speech, and equal to the product of the total capacity of the line and the total ohmic resistance.

Retarding Coil.—A choking coil.

Retarding Disc.—A copper disc supported on a rotating shaft so placed as to cut magnetic flux, and be thereby retarded in its speed of rotation.

Retardation.—A decrease in the speed of telegraphic signalling caused by distributed electrostatic induction and resistance.

Retardation Coil.—(1) A term sometimes used for choking coil. (2) An induction coil. (3) A retarding coil.

Retardation, Electric.—A retardation in

- the starting or stopping of an electric current due to self-induction.
- Retarded Quadrature.**—In a simple-harmonic-current circuit the condition of lagging in quadrature, or of phase difference amounting to 90° in lag.
- Retentiveness.**—Possessing the property of retentivity.
- Retentivity.**—Possessing the power of retaining magnetization or of resisting demagnetization.
- Retort Carbon.**—Carbon obtained from a deposit on the interior of a gas retort, and formerly used for the production of arc-light carbons.
- Return-Call Annunciator.**—An annunciator connected with an answering call-box for showing that a call sent out has been received at the central station.
- Return Charge.**—(1) A charge produced by an oscillatory return or back stroke of lightning. (2) A charge produced inductively by a lightning discharge.
- Return Circuit.**—That part of a circuit by which an electric current returns to the source.
- Return Conductor.**—The return wire.
- Return Current.**—In telegraphy the electrostatic discharge from a cable or underground wire.
- Return Current.**—The discharge current from a telegraph line passing to ground at the sending end.
- Return Feeders.**—(1) The feeders through which a current returns to a central station. (2) Negative feeders. (3) The feeders connected with the track in a trolley system. (4) Ground feeders.
- Return Feeders for Railway Circuits.** Copper conductors employed in railway circuits for re-enforcing ground-return circuits, and usually insulated.
- Return Ground.**—(1) That part of the ground employed as a return. (2) The ground-return.
- Return-Signal Call-Box.**—An answering call-box.
- Return Stroke of Lightning.**—An electric discharge induced by the direct discharge of a lightning flash, as distinguished from the direct discharge itself.
- Return-Track Feeder.**—A feeder in a trolley system connected to the track.
- Return Wire.**—The wire or conductor by means of which the current returns to the electric source after having passed through the electro-receptive devices.
- Returns.**—In a system of distribution, those conductors through which the current flows back from the electro-receptive devices to the sources.
- Reversal.**—(1) A change in direction. (2) A semi-wave.
- Reversal of Phase.**—A change in the phase of a current due either to the reversal of the current or of the conductor in which it is produced.
- Reversals.**—In telegraphy, alternate-current signals transmitted for the purpose of adjustment or for clearing the line of a charge.
- Reverse - Current Working.**—Telegraphic transmission by means of reverse currents, or double currents.
- Reverse Currents.**—(1) A name sometimes applied to alternating currents. (2) A name sometimes applied to double-currents.
- Reverse-Induced Current.**—(1) The current induced by a current in its own circuit at the moment of making or closing the circuit. (2) The current induced in a secondary circuit on making or closing a primary circuit.
- Reverser.**—Any device for reversing or changing the direction of a current.
- Reverser Bars.**—The commutator connection employed in Sayer's armature winding which carries the current during the short time that the corresponding sections are passing under the brushes.
- Reversible Bridge.**—A bridge or balance so arranged that the proportionate coils can be readily interchanged, thus permitting the bridge coils to be readily tested by reversing.
- Reversible Electric Motor.**—(1) A motor whose direction of motion is readily reversed. (2) A motor which is so arranged as to be readily operated as a generator.
- Reversible Heat.**—The heat produced in a heterogeneous conductor by the passage through it of an electric current.
- Reversible Heating Effect of Electricity.**—A term sometimes employed in place of the Peltier effect.
- Reversible Regenerative Armature.**—A regenerative armature that is capable of generating electromotive forces when the direction of its rotation is reversed.
- Reversibility of Dynamo.**—The ability of a dynamo to operate as a motor when traversed by an electric current.
- Reversing.**—Changing any direction to its opposite.
- Reversing a Current.**—Changing the direction of a current.

Reversing Cell.—A voltaic cell whose couple and electrolyte are contained in a hermetically closed vessel so arranged that when the cell is placed in one position the electrolyte does not touch the couple, and when reversed the electrolyte surrounds the couple.

Reversing Controlling-Box.—A motor controlling-box which enables the direction of rotation of the motor to be reversed.

Reversing Cylinder.—(1) The cylinder in a motor-controlling apparatus carrying the reversing contacts. (2) The contact cylinder of a reversing switch.

Reversing-Gear of Electric Motor.—Apparatus for obtaining a reversal in the direction of rotation of a motor.

Reversing-Handle of Car Controller.—(1) A switch handle placed on a car controller for the purpose of changing its direction of motion. (2) The handle of an emergency switch in a street-car controller.

Reversing Key.—(1) A key inserted in the circuit of a galvanometer for obtaining deflections of the needle on either side of the galvanometer scale. (2) A key which serves to reverse the current supplied to a circuit.

Reversing Key of Quadruplex Telegraphic System.—The key in a quadruplex system which reverses the direction of the current and so operates one of the distant instruments.

Reversing Magnetic-Field.—That portion of the field of a dynamo produced by the field-magnet coils, in which the currents flowing in the armature coils are stopped or reversed after the coil has passed its theoretical position of neutrality.

Reversing Switch.—A switch employed in reversing a circuit or current.

Revolving Primary of Induction Motor.—(1) A rotor primary. (2) In an induction motor, a revolving element connected with the line.

Revolving System.—The twist system of erecting telegraph or telephone wires, so as to avoid induction.

Rheocord.—A word formerly employed for rheostat. (Obsolete.)

Rheometer.—A word formerly employed for any device for measuring the strength of a current. (Obsolete.)

Rheomotor.—A word formerly employed to designate any electric source. (Obsolete.)

Rheophore.—A word formerly employed

to indicate a portion of a circuit conveying a current and capable of deflecting a magnetic needle placed near it. (Obsolete.)

Rheoscope.—A word formerly employed in place of galvanoscope. (Obsolete.)

Rheoscopic Limb.—A word sometimes employed for a physiological rheoscope, such as the galvanoscopic frog.

Rheostat.—An adjustable resistance.

Rheostat Frame.—A perforated frame or casing in which the separate resistances of a rheostat are placed.

Rheostat Handle of Car-Controller.—The main switch of a car-controller.

Rheostat Panel.—A panel in any switchboard to which the rheostat circuits are connected.

Rheostatic Machine.—A machine devised by Planté in which continuous static effects of considerable intensity are obtained by charging a number of condensers from storage cells connected in multiple-arc, and then discharging the condensers in series.

Rheotome.—A word formerly employed for interrupter. (Obsolete.)

Rheotometer.—A compound bridge and rheostat.

Rheotrope.—A word formerly employed for commutator or current reverser.

Rhigolene.—A highly volatile hydro-carbon obtained during the distillation of coal-oil, and sometimes employed in the flashing treatment of incandescent lamp filaments.

Rhumbs of Compass.—The points of a mariner's compass.

Ribbed Armature-Core.—A cylindrical armature core provided with longitudinal projections or ribs which serve as grooves for the reception of the armature coils.

Ribbon Conductor.—A flat, ribbon-shaped conductor.

Ribbon Copper.—A copper strip or ribbon-shaped copper conductor.

Ribbon Core.—A form of laminated core made by iron ribbons.

Ribbon Fuse.—A fuse in the shape of a ribbon.

Ribbon Induction-Coil.—An induction-coil whose primary and secondary circuits are formed of metallic ribbons instead of wires.

Ribbon Vibrator.—An electro-magnetic contact-breaker consisting of a horizontal steel ribbon, the rate of vibration of

- which can be varied by varying its tension.
- Right-Angled Trolley-Crossing.**—A trolley crossing placed at a point where two streets intersect at right angles.
- Right-Hand Trolley-Frog.**—A trolley frog used at a point where a branched trolley wire leaves the main line on the right hand in the direction of advance.
- Right-Hand Trolley-Switch.**—A term sometimes used for a right-hand trolley frog.
- Right-Handed Armature Winding.**—An armature winding applied to the core in a right-handed or dextrorsal helix.
- Right-Handed Dynamo.**—A dynamo whose proper direction of rotation is right-handed regarded from the pulley end.
- Right-Handed Helix.**—(1) A right-handed solenoid. (2) A helix wound right-handedly when regarded from either end.
- Right-Handed Motor.**—A motor arranged to run right-handedly or clockwise when regarded from the pulley end.
- Right-Handed Rotation.**—(1) A direction of rotation which is the same as that of the hands of a watch, when one looks directly at the face of the watch. (2) Negative rotation.
- Right-Handed Solenoid.**—A dextrorsal solenoid or one whose winding is right-handed.
- Right-Handed Spiral.**—A term sometimes used for right-handed solenoid.
- Right-Handed Winding.**—A winding applied in a right-handed direction.
- Ring Armature.**—An armature provided with a ring-shaped core.
- Ring-Armature Core.**—A ring-shaped armature core.
- Ring Clutch.**—A form of clutch employed for gripping the lamp rod of an arc-lamp when slightly moved from a horizontal position.
- Ring Clutch for Arc-Lamp.**—A ring-shaped clutch embracing the lamp rod, which grips or holds the rod when tilted or inclined, but permits it to fall when in a horizontal position.
- Ring-Connected Armature.**—An armature provided with ring connections.
- Ring-Connected Generator.**—A generator provided with an armature winding, in which corresponding points are connected to ring conductors for the purpose of equalizing the magnetic flux and the current distribution around the armature.
- Ring Connections of Armature.**—Conductors in the form of rings in a multipolar armature to each of which are connected corresponding points of the armature winding for the purpose of equalizing the current and magnetic flux in the machine.
- Ring Core.**—A ring-armature core.
- Ring Current of Triphase System.**—The current flowing between adjacent wires or terminals of a triphase system.
- Ring Magnet.**—A uniformly magnetized rod bent into a closed ring.
- Ring Main.**—A ring-shaped distributing main.
- Ring-Off.**—A term employed for a signal sent by a telephone correspondent when the conversation is finished.
- Ring-Off Drop.**—(1) A telephone drop released by a ring-off signal. (2) A drop placed at a central telephone station, and operated by a subscriber when he rings off or hangs up his telephone.
- Ring-Off Signal.**—A signal given by a subscriber at the close of his conversation, to inform the central station that the connection may be discontinued.
- Ring-Off Telephone-Indicator.**—Any indicator on a telephone switchboard that is operated by a ring-off signal.
- Ring Potential of Triphase System.**—The effective difference of potential or voltmeter pressure between adjacent lines or terminals of a triphase system.
- Ring-Up.**—(1) In telephony, to actuate the call-bell of a subscriber wanted. (2) To call up an operator at an exchange or a distant subscriber.
- Ring Windings.**—Windings suitable for use in a ring-wound armature.
- Ring-Wound Armature.**—An armature consisting of a ring core with coils of wire wound thereon.
- Ringer.**—A telephone magnet.
- Ringer Coils.**—The coils or winding of a telephone magneto.
- Ringer Magnet.**—A permanent magnet employed in a telephone magneto or ringer.
- Ring Keys.**—In a telephone switchboard, keys for closing a generator upon a subscriber's circuit to ring his bell.
- Ring Key.**—In a telephone switchboard, a key employed to ring up a subscriber.
- Ring Key-Bars.**—In a telephone switchboard, metallic bars connecting the ringing keys with the instrument bars and generator.

Rings, Electric.—A term sometimes used instead of Nobili's rings.

Ripple Marks, Electric.—Wave marks produced in a fine powder by a neighboring Leyden-jar discharge.

Risers.—(1) Supply wires which lead the current from the service wires to the different floors of a building. (2) The supply wires which rise to the various floors, as distinguished from floor mains, submains, or branches, which run along each floor.

River Cable.—(1) A cable suitable for use in a river. (2) A form of sub-aqueous cable.

Riveted Railway-Joint.—A rail-bond in which the connection between two contiguous rails is obtained by riveting specially heavy fish-plates to each end of the rail.

Riveting Apparatus, Electric.—A riveting apparatus employing electrically generated heat.

Roaring of Arc.—A roaring sound attending the formation of a powerful voltaic arc when the carbons are too near together.

Rock-Drill, Electric.—An electrically operated rock-drill.

Rocker Arm.—An arm on which the brushes of a dynamo or motor are mounted for the purpose of shifting their position on the commutator.

Rocker-Arm Circle.—The frame of a dynamo-electric machine which supports the brush arms and is capable of adjustment in angular position.

Rocking Switch.—An automatic throw-over switch.

Rod Clamp.—A clamp employed in the lamp-rod of an arc-lamp.

Rod Clutch.—The clutch employed for gripping an arc-lamp rod.

Rod Switch.—A switch provided for lighting and extinguishing a lamp, so arranged that it can readily be pushed to its off or on position by means of a rod.

Rodding a Conduit.—The process of introducing a drawing-in wire through the ducts of an underground conduit by pushing a number of short sections of jointed rods through such ducts.

Roentgen Effects.—The peculiar effects produced by Roentgen or X-rays.

Roentgen Ether Waves.—A term sometimes employed for Röntgen rays.

Roentgen Radiograph.—A word proposed for radiograph.

Roentgen-Ray Picture.—A word proposed for radiograph.

Roentgen-Ray Screen.—(1) A screen covered with fluorescent material intended to receive a visible Roentgen picture. (2) A fluoroscopic screen.

Roentgen Ray Transformer.—An alternating-current transformer suitable for operating a Roentgen ray tube.

Roentgen-Ray Tube.—A vacuum tube for the production of Roentgen rays, or X-rays.

Roentgen Rays.—A peculiar radiation emitted in the neighborhood of that portion of a high vacuum tube on which the cathode rays fall.

Roentgen Shadow Print.—A radiograph.

Roentgen Streams.—(1) Roentgen or X-rays. (2) A term applied to the Roentgen rays, by those who regard them as consisting of actual streams of matter thrown off, either from the cathode, or from the residual atmosphere of the vacuum tube.

Roentgen Tube.—Any high-vacuum tube capable of producing Roentgen rays.

Roentgengram.—A word proposed for radiograph.

Roentgenograph.—A word proposed for radiograph.

Roget's Spiral.—(1) A spiral, helix or solenoid, freely suspended at its upper end so that its lower end shall dip in a mercury surface, which when traversed by a sufficiently powerful current will break its own circuit by the attraction produced by its adjacent convolutions when by its weight it will complete the circuit, and thus be alternately opened and closed. (2) A form of automatic contact-breaker.

Roman Vitriol.—A name formerly applied to blue-stone or copper sulphate.

Rontgram.—A word proposed for radiograph.

Rontgraph.—A word proposed for radiograph.

Rontgraphy.—A word proposed for radiography.

Roof Box of Push.—A term sometimes employed for the upper covering of the box of a push-button.

Roof Bracket.—(1) An insulator bracket, either straight or offset for attachment to a roof. (2) A form of house fixture provided for the support of overhead wires.

Roof Standard.—A form of house fixture provided for overhead wires.

- Room Call, Electric.**—Any device placed in the room of a hotel for the purpose of automatically sending calls to the office.
- Rope Transmission.**—Transmission of power by means of ropes or cables.
- Rosette.**—(1) An ornamental plate provided with service wires and placed in a wall or ceiling for the ready attachment of an electric lamp or electrolier. (2) A word sometimes used in place of ceiling rose.
- Rosette Cut-Out.**—A rosette for an electrolier, provided with a cut-out.
- Rotary Converter.**—A secondary generator for transforming alternating into continuous currents or *vice-versâ*, consisting of an alternating-current machine whose armature winding is connected with a commutator; or of a continuous-current machine, whose armature is tapped at symmetrical points and connected to collector rings; so that, when the armature runs it is an alternator on one side and a direct current machine on the other. (2) A rotary transformer.
- Rotary Current.**—(1) A name applied to any system of polyphase currents which are capable of producing a rotary field. (2) A rotating-current distribution.
- Rotary-Current Transformer.**—A transformer capable of being operated by a rotary current.
- Rotary Electric Field.**—A rotary electrostatic field.
- Rotary Electro-Type.**—(1) A term sometimes used for a turtle-back. (2) Any electro-type with a curved surface suitable for printing in a cylinder press.
- Rotary-Field Induction-Motor.**—An induction motor operated by a rotary field.
- Rotary-Field Motor.**—A rotary-field induction-motor.
- Rotary Induction Transformer.**—A rotary-current transformer.
- Rotary-Magnetic Field.**—(1) A field produced by a rotary current. (2) A magnetic field in which a set of magnet poles is produced, whose successive positions are such that a rotation of the field is effected.
- Rotary-Magnetic Polarization.**—The rotation of the plane of polarization of a beam of plane-polarized light, consequent on its passage through a medium subjected to the stress of a magnetic field.
- Rotary Magnetism.**—The magnetism produced by a rotary magnetic field.
- Rotary-Phase Alternating-Currents.** Rotary-phase currents.
- Rotary-Phase Currents.**—A term sometimes employed for a rotating electric current distribution.
- Rotary-Phase Dynamo.**—A term sometimes employed for a rotating-current dynamo.
- Rotary Transformer.**—(1) A term generally employed for the combination of a motor and generator in one machine having a single armature-winding traversed both by alternating and continuous currents. (2) A secondary generator for transforming from alternating to continuous currents or *vice-versâ*. (3) A rotary converter.
- Rotating Brushes of Dynamo.**—(1) Rotating discs of metal employed in place of the ordinary brushes for carrying off the current from the armature of a dynamo. (2) Brushes revolved around the periphery of a commutator.
- Rotating Current.**—(1) A term applied to the current which results by combining a number of alternating currents, whose phases are definitely displaced with respect to one another. (2) A polyphase or multiphase current.
- Rotating-Current Field.**—A magnetic field produced by a rotating current.
- Rotating-Current Motor.**—A motor operated by a rotating current.
- Rotating-Current Transformer.**—A rotary-current transformer.
- Rotating Transformer.**—(1) A rotary transformer. (2) An induction motor.
- Rotating Vector.**—A line or vector quantity which rotates about a fixed point.
- Rotometer.**—A form of cyclometer attached to a drum for measuring the amount of cable passing over the drum in picking up or paying out a submarine cable.
- Rotor.**—That portion of a dynamo-electric machine which rotates.
- Rotor Armature.**—An armature which rotates.
- Rotor Circuit.**—The circuit of a rotor.
- Rotor Coils.**—The coils placed on a rotor.
- Rotor Currents.**—The currents produced in the rotor coils.
- Rotor Field.**—The field of a rotor.
- Round Wire-Gauge.**—A wire gauge consisting of a circular plate provided on its circumference with slots of various sizes.
- Rubber of Electric Machine.**—That portion of a frictional machine which produces the electricity by rubbing against a disc or plate.

Rubber Tape.—A form of adhesive, insulating tape made of rubber.

Rubbing Contact.—A contact effected by means of a rubbing motion.

Rubbing Contact Key.—A key provided with a rubbing contact.

Ruhmkorff Coil.—(1) An early form of induction coil or step-up transformer. (2) An induction coil having an iron-wire core, and a fine wire secondary coil of many turns for the production of powerful induced E. M. F.'s, usually excited from a battery or continuous-current source through a suitable current breaker.

Ruhmkorff Commutator.—A commutator employed in a Ruhmkorff coil for reversing the direction of the current through the primary.

Rumble.—A barrel, or hollow box, rotated by mechanical power, in which small articles are prepared for electro-plating by the polishing obtained by their attrition against one another, or against hard objects placed therein.

Run-Down Cell.—An exhausted cell.

Running-Board.—A device employed in the construction of a heavy overhead line,

consisting in placing a number of reels of wire, usually ten or more, on a spindle, and arranging a piece of wood as a cross-arm to which ten or more wires are attached, harnessing horses to the cross-piece, and then dragging the running board away as the wires are paid out from the reels, and passing them over their appropriate cross-arms, where they are at once secured to the insulators by line-men.

Running Guard-Wire.—A wire provided in a system of aerial trolley circuits, extending parallel to and immediately above the trolley wire, intended to intercept any wire falling on the line from above.

Running Position of Street-Car Controller.—A position of the switch-handle of a street-car controller at which current is supplied to the car-motors and they are kept in rotation, as distinguished from a position in which the current is cut-off.

Running Rope.—A rope attached to the running-board employed in the stringing of aerial wires.

Running Torque of Motor.—The torque exerted by a motor while running, as distinguished from the starting torque.

S

S.—A contraction proposed for surface.

S.—A contraction proposed for second.

s.—An abbreviation for second, the C. G. S. unit of time.

S. C.—A contraction for secondary current.

S. G.—In submarine telegraphy, the prefix for a service message, or a message relating to the business of the company only.

S. H. M.—A contraction for simple-harmonic motion.

S. P. D.—A contraction for secondary potential difference.

S. N. Code.—A contraction for single-needle code.

S. N. Telegraphic-Instrument.—A contraction employed for single-needle telegraphic instrument.

S. P. Cut-Out.—A contraction for single-pole cut-out.

S. R. G.—A contraction for standard railroad gauge or $4.8\frac{1}{2}$ ".

S. W. G.—A contraction for the British standard wire gauge.

S. W. G.—A contraction for Stubb's wire gauge.

Saddle Bracket.—A bracket holding an insulator and fastened to the top of a telegraph or telephone pole.

Safe Alarm.—An electro-magnetic alarm connected with a safe and designed to give notice of an attempt to force the same.

Safe Carrying Capacity of a Conductor.—The maximum electric current a conductor will carry without becoming unduly heated.

Safety Catch.—A safety fuse.

Safety-Catch Holder.—A holder for a safety fuse.

Safety Cut-Out.—A safety fuse.

Safety Device.—Any device by means of which a circuit is automatically opened or short-circuited when the current passing through it exceeds certain pre-determined limits.

Safety Device for Arc-Lamps or Series Circuit.—Any mechanical device which automatically provides a path for a current around a lamp, or other faulty receptive device in a series circuit, and thus prevents the opening of the entire circuit on the failure of such device.

Safety Device for Multiple Circuit.—

(1) A safety fuse. (2) A fuse wire or strip. (3) Any device for protecting a branch circuit, instrument or conductor from an excessive current.

Safety Factor of Transformer.—The ratio of the voltage with which a transformer has been tested, to the voltage at which it is operated.

Safety Fuse.—A wire, bar, plate or strip of readily fusible metal, capable of conducting, without fusing, the current ordinarily employed on the circuit, but which fuses and thus automatically breaks the circuit on the passage of an abnormally strong current.

Safety Fuse-Block.—A block provided for the reception of a safety fuse.

Safety Lamp, Electric.—(1) An incandescent lamp, provided with thoroughly insulated leads, employed in mines or other similar places, where the explosive effects of readily ignited substances are to be feared. (2) A portable electric incandescent lamp and battery for use in mines where explosive gases may be found.

Safety Link.—A link-shaped safety-fuse.

Safety Plug.—(1) A safety fuse. (2) An insulating screw-plug containing a safety fuse, which by its insertion in a suitably prepared socket, automatically closes the circuit through such fuse.

Safety Strip.—A strip of fusible metal employed as a safety fuse.

Sag of Conductor or Line Wire.—The dip of an aerial wire or conductor, between two adjacent supports, due to its weight.

Sag Error.—(1) Any error in installing an aerial wire due to insufficient allowance for sag with change of temperature. (2) Any error in computing the length of an aerial wire due to insufficient allowance for sag.

Saint Elmo's Fire.—Tongues of faintly luminous flame which sometimes appear on the pointed ends of earth-connected bodies, such as the tops of church steeples, or the masts of ships.

Salient Magnetic Poles.—A term sometimes applied to the single poles located at the extremities of an anomalous magnet, in order to distinguish them from the double or consequent poles formed by the juxta-position of two similar magnetic poles.

Salimeter.—A form of hydrometer suitable for measuring the density of a saline solution.

Saline Creeping.—The formation, by efflo-

rescence, of salts on the walls of a solid immersed in a saline solution.

Saline Solution.—A solution of a salt in a liquid.

Sand-Barrel Setting for Pole.—A stout barrel or cask, placed in the bottom of an excavation in a loose, sandy soil, as a pole foundation in which the butt of the pole is placed, and a firm loam or clay tightly packed into the barrel around the pole.

Sand-Box for Electric Car.—A box employed for holding sand, so arranged as to distribute it over a track as desired, for the purpose of increasing the friction.

Sanding Device.—A device employed for sprinkling sand over a car-track.

Sandy Electro-Metallurgical Deposit.—A non-coherent electro-metallurgical deposit, which occurs when the current density exceeds its normal value.

Sash Lines.—Ropes employed in raising telegraph poles to the vertical position.

Saturated Solution.—A solution in which as much of the solid has been dissolved as the solvent will take at a given temperature.

Saturating Flux.—The flux required to produce magnetic saturation in any circuit.

Saw, Electric.—An electrically operated saw.

Saw-Tooth Lightning - Arrester.—A name sometimes applied to a comb lightning-arrester.

Sayers Armature Winding.—An armature winding provided with additional coils called commutator coils which are subjected to the influence of an auxiliary pole and which are introduced into the main circuit to obtain sparkless commutation.

Scalar.—The name given to a quantity which has no directive property, or which has numerical magnitude only, such as temperature, or energy, as distinguished from a vector quantity.

Scalar Potential.—A potential possessing magnitude and sign without direction, as distinguished from a vector potential which possesses both direction and magnitude.

Scale Zero.—(1) An instrument zero. (2) A zero selected at the zero mark of a scale.

Scarf Joint of Conductors.—A joint between the ends of conductors in which the ends are prepared by filing them diagonally, so that when laid together and soldered, the joint is cylindrical in shape,

- presents no rough edge, and, unlike a butt joint, extends over an appreciable length.
- Schiseophone.**—An electro-mechanical appliance for detecting flaws or internal defects in rails or other metallic masses.
- Schweigger's Multiplier.**—A name formerly given to a coil consisting of a number of turns of insulated wire, provided for the purpose of increasing the strength of the magnetic field produced by an electric current, and so increasing the amount of its deflecting power on a magnetic needle.
- Sciagraph.**—A word proposed for radiograph.
- Sciagraphic Print.**—A word sometimes used for radiograph.
- Sciagraphy.**—A word proposed for radiography.
- Scintillating Jar.**—A Leyden jar whose coatings, instead of being formed of continuous sheets of tin-foil, are formed of small pieces, placed at regular intervals on the glass or dielectric, so as to leave a small space between them.
- Scratch Brush.**—A brush made of wires, or of stiff bristles, employed for cleansing the surfaces of metallic objects before subjecting them to the electro-plating process.
- Scratch Brushing.**—Cleansing the surfaces of articles to be electro-plated by friction with a scratch brush.
- Screen, Electric.**—A closed conductor placed over a body in order to protect or screen it from the effects of external electro-static fields.
- Screening.**—Protecting a body from the effect of an electrostatic or electro-magnetic field by means of a screen.
- Screening Effect of Eddy Currents.**—A term sometimes used for the effect produced by eddy currents in a solid mass of iron or steel, of shielding the interior of the mass from an externally applied alternating magnetic field.
- Screw Block-Fuse.**—(1) A form of plug cut-out. (2) A screw-plug in a receptacle or block containing a fuse.
- Screw Cleat.**—A cleat provided with a screw for its ready attachment to wood-work.
- Sea Cell Test.**—In a sub-marine system of electric torpedoes, a circuit test by means of a single voltaic cell in which sea water is the electrolyte.
- Sea Telegraphy.**—(1) Submarine Telegraphy. (2) Telegraphy carried on at sea either between neighboring vessels or between different parts of the same vessel.
- Seal of Meter.**—A leaden seal placed on a meter, after it has been properly installed, for preventing its being tampered with.
- Sealing-In of Filament.**—Effecting a hermetical seal between the support of the filament of an incandescent lamp and the lamp chamber in which it is placed.
- Sealing-Off of Lamp Chamber.**—Hermetically closing a lamp chamber while it is connected with the pumps, by the fusing of the glass.
- Sealing Tools.**—Tools employed for placing a seal on a meter.
- Sealing Wires.**—Wires employed for forming part of the seal of a meter.
- Search-Light, Electric.**—A focussing arc light placed in front of a reflector or lens, for the purpose of obtaining an approximately parallel beam of light for lighting the surrounding space.
- Searching Coil.**—A term sometimes applied to an exploring coil.
- Secohm.**—(1) The practical unit of self-induction, or of inductance. (2) A length equal by definition to that of an earth quadrant, or very nearly 10^9 centimetres. (3) A henry.
- Secohmmeter.**—An apparatus for measuring the self-inductance, the mutual inductance, or the capacity of conductors.
- Secondary.**—A word frequently employed for the secondary coil of a transformer or induction coil.
- Secondary Accumulator.**—A storage-cell accumulator.
- Secondary Ampere-Turns.**—Ampere-turns in the secondary of a transformer or induction coil.
- Secondary Admittance.**—The admittance of a secondary circuit.
- Secondary Battery.**—A word frequently used for storage battery.
- Secondary Cell.**—A word frequently used for storage cell.
- Secondary Clock.**—Any clock in a system of time telegraphy that is controlled by a master clock.
- Secondary Coil of Transformer.**—(1) The coil of a transformer into which energy is transferred from the primary line and primary coil. (2) The secondary winding of a transformer or induction coil. (3) The driven coil of a transformer. (4) The coil in the external circuit of

which there is no directly impressed E. M. F.

Secondary Currents.—(1) The currents produced in the secondary of a transformer. (2) The currents produced by secondary batteries. (3) Currents in any secondary circuit.

Secondary Electromotive Forces.—A name sometimes given to the electromotive forces produced by a secondary cell or battery.

Secondary Element of Induction Motor.—Those portions of an induction motor, closed upon themselves, in which currents are induced.

Secondary Frequency of Induction Motor.—The frequency of the alternating currents induced in the secondary circuits of an induction motor, comprising only a small fraction of the frequency in the primary circuit or circuits.

Secondary Fuse-Box.—A fuse box placed in the secondary circuit of a transformer or induction coil.

Secondary Generator.—(1) A generator which is not a prime source of energy, but receives its energy from some other electrical circuit either at some antecedent period, as in the case of a storage cell, or coincidentally, as in the case of a transformer. (2) A term sometimes employed for transformer.

Secondary Generator.—A device employed in alternating-current circuits for obtaining the working pressure on one circuit by induction from a neighboring circuit.

Secondary Impressed Electromotive Force.—The E. M. F. impressed upon a secondary circuit, as distinguished from the E. M. F. that is active in producing current, or the E. M. F. exerted in overcoming self-induction.

Secondary Impedance.—In a secondary circuit, the impedance, either of part, or of all of the circuit.

Secondary Movers.—The driven shafts or machines, as distinguished from the driving shafts or machines.

Secondary Plate of Condenser.—That plate of a condenser in which a charge is induced by the presence of a charge on the opposite plate.

Secondary Primary.—A winding on an induction coil intermediate between the secondary and primary windings, arranged with the aid of revolving contacts to serve, in each cycle, first as a secondary, and next as a primary winding, for the purpose of reducing the sparking at the

contact wheel of the primary coil when excited from an incandescent-lighting continuous-current circuit.

Secondary Resistance.—The resistance of a secondary coil or circuit.

Secondary Spiral of Induction Coil.—A term sometimes employed for the secondary winding of an induction coil.

Secondary Standard of Light.—Any standard of photometric intensity of light that is not a fundamental standard, but which is used as an intermediary to, or with reference to, a fundamental standard.

Secret Telephone System.—A domestic telephone system arranged so that telephonic communication can be obtained between any two stations without being overheard by a person at any other station, and without the aid of an attendant or exchange.

Secretion Current.—A current following electric stimulation of the secretory nerves.

Section.—(1) A part. (2) A cutting plane. (3) A graphical representation of the appearance that is, or would be, presented by a body when exposed at a cutting plane. (4) In a trolley system, a portion or length of trolley conductor insulated from adjacent portions.

Section Box.—In a trolley system, a box containing the connection to a section and the switch by which it is connected to a feeder.

Section Circuit-Breaker.—A magnetic circuit-breaker controlling a trolley-wire section.

Section of Multiple Switchboard.—A complete division or reduplicating unit of a switchboard, in which every jack appears once.

Section of Switchboard.—A term sometimes used for a panel or a part of a panel of a switchboard.

Section Insulator.—An insulator in a trolley-wire system, which electrically disconnects one trolley section from another.

Sectional Feeding-Point.—In a street-railway system, a point where a feeder connects with a section of trolley wire or main-supply conductor.

Sectional Plating.—Plating an article with a greater thickness of metal at certain points than at the rest of the surface.

Sectional Plating-Frame.—A frame employed for holding an object to be electroplated so that it shall receive a greater

- depth of deposit on certain portions of its surface than elsewhere.
- Sectional Trolley-Line.**—A system of trolley wires divided into sections.
- Sectioned Coils for Magnet.**—(1) A term employed for a method of winding a magnetizing coil, in separate compartments. (2) Dividing a winding space into short axial sections, and filling each with wire.
- Secular.**—Of or pertaining to cycles of time.
- Section Switch.**—In a system of railway or power-distribution, a switch controlling and supplying a section.
- Secular Variation.**—A variation in the magnetic declination, which occurs at cycles or great intervals of time, as opposed to diurnal or annual variations.
- Seebeck Effect.**—A term sometimes employed for thermo-electric effect.
- See-Sawing.**—A term employed to characterize the condition of two parallel-connected alternators when they do not synchronize properly.
- See-Sawing of Parallel-Connected Generators.**—(1) A term sometimes applied to the hunting of generators. (2) Imperfect synchronism between generators.
- Segment Switch.**—A switch in which a pivoted strip or lever moves over the arc of a circle divided into insulating segments.
- Segmental Core-Disc.**—A dynamo core-disc which, instead of being made in one piece, is formed of suitable joined segments.
- Seismic Photo-Chronograph.**—A chronograph that photographically records seismic disturbances.
- Seismograph, Electric.**—An apparatus for electrically recording the direction and intensity of earthquake shocks.
- Selectance.**—The property by virtue of which resonant electric circuits respond more to one frequency of alternating current than to another.
- Selective Absorption.**—The absorption of a particular or selected character of the waves of sound, light, heat or electricity.
- Selective Consonance.**—That property of a consonant alternating-current circuit by virtue of which it responds more to one frequency than to another.
- Selective Emission.**—Selective radiation.
- Selective Opacity.**—(1) Opacity limited to certain frequencies only. (2) Selectivity as regards transparency.
- Selective Radiation.**—(1) Radiation limited to certain frequencies. (2) Selectivity as regards radiation.
- Selective Resonance.**—The property of a resonant circuit which renders it selective to a definite frequency of alternating current.
- Selective Signal.**—(1) A term sometimes employed for an individual signal. (2) A signal which affects one only of a plurality of translating devices connected to a circuit.
- Selective-Signal Pendulum.**—A system of selective signalling in which the receiving bells respond each to a single alternating-current frequency, and the transmitting frequency is adjusted correspondingly by altering the virtual length of a pendulum swinging in the transmitter.
- Selective Signalling-Apparatus.**—A term sometimes employed for individual signalling-apparatus.
- Selectivity.**—(1) The capability for developing selective action. (2) The degree of capability for effecting selection.
- Selenium.**—A comparatively rare element, generally found associated with sulphur, the electric resistance of which is affected by light.
- Selenium Battery.**—A number of separate selenium cells connected so as to form a single cell or battery.
- Selenium Cell.**—A cell consisting of a mass of selenium fused in between two conducting wires or electrodes of platinumized silver, or other suitable metal.
- Selenium Eye.**—A rough model of the human eye in which a selenium resistance takes the place of a retina and two slides the place of the eyelids.
- Selenium Photometer.**—(1) A photometer in which the intensity of the light is estimated by the comparison of the changes in the resistance of a selenium resistance, successively exposed under similar conditions to the light to be measured and to a standard light. (2) A photometer employing the photo-electric properties of selenium.
- Selenium Resistance.**—A mass of selenium employed as a resistance, whose value varies with the variations in the intensity of the light to which it is exposed.
- Self-Acting Make-and-Break.**—A term sometimes employed for an automatic make-and-break.
- Self-Aligning-Bearings.**—Journal bear-

- ings so constructed and adjusted as to permit of a slight angular range of movement in order to conform to the surface of the shaft.
- Self-Cleaning Contact Key.**—A name sometimes given to a key provided with a rubbing contact.
- Self-Closing Telegraphic Key.**—A telegraphic key provided with an automatic switch in its knob, so that pressing the key opens the switch, and releasing the key automatically closes the switch.
- Self-Compounding Polyphase Generator.**—A polyphase generator whose field magnets are compound-wound, and which supplies the series winding with currents conductively or inductively associated with those in the line.
- Self-Contained Engine or Machine.**—An engine or machine all of whose working parts are within the said engine or machine.
- Self-Cooling Transformer.**—(1) A transformer which maintains its temperature within the necessary safe limits by natural radiation and conduction, without the use of any external cooling apparatus. (2) An oil or air-insulated transformer in which no forced circulation of the air or oil is employed.
- Self-Demagnetizing Force.**—The force exerted by a permanent bar magnet tending to demagnetize itself, owing to the passage of some of its flux back through the bar in the opposite direction to the magnetization through the substance of the steel.
- Self-Excitation.**—An excitation of the field magnets of a generator obtained by leading a portion or all of its own current through its field coils, as distinguished from separate excitation.
- Self-Excited.**—Excited by means of its own current.
- Self-Excited Alternator.**—An alternator whose fields are self-excited.
- Self-Excited Dynamo.**—A dynamo whose field is self-excited.
- Self-Excited Series-Wound Continuous-Current Generator.**—A continuous-current generator having a series-wound field which is excited by the current supplied from the armature of the generator.
- Self-Excited Shunt-Wound Continuous-Current Generator.**—A continuous-current generator having a shunt-wound field which is excited by a small part of the current supplied by the armature and diverted from the external circuit for that purpose.
- Self-Induced Current.**—A current induced in a circuit, on the opening or closing of the circuit, by changes in its own strength.
- Self-Induction.**—Induction produced in a circuit by the induction of the current on itself at the moment of starting or stopping the current therein.
- Self-Induction Coil.**—(1) A coil of wire possessing self-induction. (2) A choking coil.
- Self-Locking Annunciator Drop.**—A name sometimes given to a self-restoring telephone drop.
- Self-Locking Pole Ratchet.**—A ratchet-winder for raising and lowering an arc-lamp on a pole, and provided with a self-locking attachment.
- Self-Oiling Bearings.**—(1) Bearings provided with automatic oilers. (2) Bearings which lubricate themselves when the shaft is rotating.
- Self-Oiling Journal.**—A journal provided with automatic oilers.
- Self-Polarizing Relay.**—A relay provided not only with the ordinary set of magnetizing coils, but also with an additional magnetizing coil for the magnetization of its tongue, so that the magnetism of the tongue is reversed when the current reverses.
- Self-Recording Magnetometer.**—A magnetometer which is capable of continuously recording the daily and hourly variations of the earth's magnetic field.
- Self-Registering Tachometer.**—A tachometer that provides a permanent record of the varying speed of the machine to which it is connected.
- Self-Registering Wire-Gauge.**—A wire-gauge arranged so as to register the diameter of the wire to be measured.
- Self-Regulating Dynamo.**—A self-regulating generator.
- Self-Regulating Generator.**—A generator so wound as to automatically maintain either a constant-current in the circuit, or a constant difference of potential between its terminals, despite changes in the resistance of its load.
- Self-Regulating X-Ray Tube.**—An X-ray tube provided with an automatic means of adjusting the degree of vacuum, and, therefore, the electric pressure at its terminals.
- Self-Regulation.**—Any form of automatic regulation.

Self-Restoring Annunciator Drop.—An annunciator drop so arranged as to be capable of replacing itself, thus dispensing with a manual replacement.

Self-Restoring Indicator.—(1) An indicator which will automatically resume its proper position. (2) A self-restoring drop or annunciator.

Self-Starting Alternating-Current Motor.—(1) An alternating-current motor which is capable of starting at any normal load. (2) A non-synchronous motor.

Self-Starting Synchronous Motor.—An alternating-current synchronous motor which is in any way enabled to be self-starting when connected with the mains.

Self-Winding Clock.—A clock that is automatically wound at regular intervals by the action of a small electro-magnetic motor, contained within the clock, and operated by one or more voltaic cells concealed in the case of the clock.

Semaphore.—A variety of visual signal apparatus employed in railroad block systems.

Semaphore Arm.—A movable arm of a signal apparatus employed in block systems for railroads, for the purpose of indicating the condition of the road as regards other trains.

Semaphore Indicator.—(1) An annunciator in which a gravity drop or shutter is caused to fall by the action of an electric current, thus exposing a number or other signal back of the drop or shutter. (2) An indicator employed in a semaphoric signalling apparatus. (3) The movable shutter or drop employed in a semaphore.

Semaphoric Electroscope.—A name sometimes given to a particular form of quadrant electroscope.

Semi-Circular.—Of or pertaining to a semi-circle or half a circle.

Semi-Circular Deviation of Mariner's Compass.—A term employed in contradistinction to the quadrantal deviation for the deviation of a magnetic needle, due to the permanent magnetism of the ship, having its resultant in a horizontal plane, and changing sign twice in a complete revolution of the ship.

Semi-Circular Error of Compass Needle.—The semi-circular deviation of the mariner's compass.

Semi-Conductor.—A name applied to a group of bodies whose conducting power is, roughly, midway between that of good conductors and insulators.

Semi-Incandescent Electric Lamp.—An electric lamp in which the light is due to the combined effects of an electric arc and of incandescence.

Semi-Period.—(1) A half period. (2) The time occupied by a reversal or alternation.

Semi-Permanent Telegraph Line.—In military telegraphy, a line intermediate in character and method of construction between a permanent line and a temporary line.

Semi-Permeable Septum.—A septum which will permit the passage through it of a solvent, but not of the dissolved substance.

Sending End of Line.—The end of a telegraphic line from which the signals are sent.

Sending Leg of Telegraphic Loop.—The wire of a telegraphic loop upon which messages are sent, as distinguished from the receiving leg.

Sending Signaller.—The operator on a telegraphic line who is sending the signals as distinguished from one at the other end who is receiving them.

Sense of Magnetic Force.—A word sometimes used for direction of magnetic force.

Sensibility of Galvanometer.—(1) The readiness and degree to which the needle of a galvanometer will respond to the passage of an electric current through its coils. (2) The reciprocal of the current required to produce a definite small angular deflection. (3) The deflection produced by a definite small current strength. (4) The figure of merit of a galvanometer.

Sensitive Flame.—A flame which alters its shape or size on the sounding of notes possessing the same frequency as that which it is capable of producing.

Sensitive Discharge.—A thin, thread-like discharge that occurs between the terminals of a high-frequency induction coil.

Sensitive Telephone.—A telephone that is able to properly respond to currents smaller than those ordinarily employed in telephone apparatus.

Sensitive Tube.—A coherer.

Sensitiveness of Wheatstone's Balance.—The minimum change in the measured resistance which, under the conditions of the test and with the apparatus employed, is capable of either being detected, or of producing the unit of scale deflection in the galvanometer.

Sent Current.—The current employed in transmitting a signal.

- Separable Conducting Cord Tip.**—A telephone plug arranged for ready connection with, or disconnection from, a flexible conducting cord.
- Separable Iron Core.**—An iron core which can be removed from the apparatus in which it is used.
- Separate-Circuit Dynamo.**—(1) A term sometimes employed for a self-exciting dynamo in which a special or separate armature circuit is connected to the fields. (2) A dynamo capable of supplying a plurality of separate circuits.
- Separate-Circuit Motor.**—A term sometimes applied to a motor whose armature is provided with two windings having two separate commutators, the main one being supplied with the driving current.
- Separate-Coil Alternator.**—An alternator whose field magnets are excited by means of current taken from the coils of the armature after it has been commuted.
- Separate-Coil Dynamo-Electric Machine.**—A term sometimes used for a separate-coil alternator.
- Separate-Coil Machine.**—(1) A machine in which the armature coils are mechanically separated from each other, as distinguished from a machine in which the coils are interlaced. (2) A dynamo-electric machine in the armature of which there exists a separate coil or winding for the special purpose of exciting the field magnets.
- Separate Excitation.**—The excitation of the field magnets produced by a source external to the machine.
- Separate Touch.**—A phrase sometimes employed for magnetization by separate touch.
- Separately-Excited Alternator.**—An alternator whose field magnets are separately excited.
- Separately-Excited Dynamo-Electric Machine.**—A dynamo-electric machine whose field coils are separately excited.
- Separately-Excited Field.**—The field of a dynamo that receives its magnetizing current from a source outside or separate from the dynamo.
- Separator.**—A corrugated and perforated insulating sheet of ebonite or other similar substance, shaped so as to conform to the outlines of the plates of a storage battery, and placed between them at suitable intervals in such a manner as to prevent their short-circuiting, but without impeding the free circulation of the liquid.
- Septum.**—The porous partition of an endsmometer.
- Series and Magneto Dynamo-Electric Machine.**—A compound-wound dynamo in which the armature circuit of a magneto-electric machine is connected with and excites the fine winding on the field magnets.
- Series-and-Separately-Excited Dynamo-Electric Machine.**—A compound-wound dynamo whose field-magnet cores are wound with two separate circuits, one connected in series with the field magnets and the external circuit, and the other with some source by means of which it is separately excited.
- Series- and -Shunt- Wound Dynamo-Electric Machine.**—A compound-wound dynamo whose field magnets are wound with two separate coils, one in series with the armature and the external circuit, and the other in shunt with the armature.
- Series-Arc Cut-Out.**—A device for automatically providing a short-circuit past a faulty lamp in a series-connected circuit, so that the failure of a lamp to operate may not interfere with the operation of the rest of the lamps.
- Series Board.**—A series-connected multiple telephone switchboard.
- Series Circuit.**—A circuit in which the separate sources or separate electro-receptive devices, or both, are so placed that the current produced in it or passed through it passes successively through the entire circuit from the first to the last.
- Series-Connected Battery.**—A battery of series-connected cells.
- Series-Connected Incandescent Lamps.**—A number of lamps connected to a circuit in series and provided with a film or other similar cut-out, to prevent the failure of a single lamp from extinguishing all the rest.
- Series-Connected Electro-Receptive Devices.**—A number of electro-receptive devices connected to a circuit in series.
- Series-Connected Sources.**—A number of separate sources so connected in series as to act as a single source.
- Series-Connected Translating Devices.**—A term sometimes used for series-connected electro-receptive devices.
- Series-Connected Voltaic Cells.**—A number of voltaic cells so connected in series as to be capable of acting as a single source or battery.
- Series Connection.**—Such a connection of a number of separate electric sources or electro-receptive devices or circuits

that the current passes successively from the first to the last in the circuit.

Series-Connection for Condensers.—

The connection of a number of condensers in series.

Series-Connection of Alternators.—The connection of two or more alternators in series.

Series Converter.—A series transformer.

Series Distribution.—A distribution of electric energy in which the receptive devices are placed one after another in succession upon a single conductor, extending throughout the entire circuit from pole to pole.

Series Dynamo.—A series-wound dynamo.

Series Field-Terminals of Motor.—The terminals of a compound-wound motor which are connected to the ends of a series field-winding.

Series Grouping of Armature Conductors.—(1) A two-circuit multipolar winding. (2) A winding for a multipolar armature in which only two paths are provided for the current between the brushes.

Series Incandescent Lamp.—An incandescent lamp suitable for use in a series circuit.

Series Incandescent Lighting System. A system of incandescent lighting in which the lamps are connected in series, as distinguished from a multiple system in which they are connected in parallel.

Series Motor.—(1) A motor suitable for use in a series circuit. (2) A series-wound motor.

Series-Multiple.—A series-multiple connection.

Series-Multiple Car-Controller.—A controller provided for starting and stopping a double motor car, for varying its speed, or the torque of its motors, by connecting the motors either in series or in parallel with or without resistances.

Series-Multiple Circuit.—A compound circuit in which a number of separate sources, or separate electro-receptive devices, or both, are connected in a number of separate groups in multiple arc, and these separate groups subsequently connected in series.

Series-Multiple-Connected Electro-Receptive Devices.—A connected system in which a number of separate electro-receptive devices are joined in parallel in separate groups, and all of these groups subsequently connected in series.

Series-Multiple-Connected Sources.—The connection of a number of separate

electric sources so as to form a single source, in which the separate sources are connected in a number of separate multiple groups or circuits, and these groups or circuits separately connected together in series.

Series-Multiple-Connected Translating Devices.—Series-multiple-connected electro-receptive devices.

Series-Multiple Connection.—Such a connection of a number of separate electro-receptive devices that the devices are placed in multiple groups or circuits and these separate groups afterwards connected with one another in series.

Series-Multiple Switchboard.—A telephone switchboard, in which a subscriber's jacks are connected in series, while plug connections are made in parallel or across the circuit.

Series-Parallel Controller.—A series-multiple car-controller.

Series Transformer.—A term sometimes applied to a converter whose primary coil is connected in series with the primary coils of other similar transformers in the primary circuit.

Series Turns of Dynamo-Electric Machine.—The magnetizing field-magnet coils of a dynamo that are connected in series with the armature circuit.

Series Winding.—A winding of a dynamo-electric machine in which a single set of magnetizing coils are placed on the field-magnet cores and connected in series with the armature and the external circuit.

Series-Wound Dynamo-Electric Machine.—A dynamo-electric machine in which the field circuit and the external circuit are connected in series with the armature circuit, so that the armature current passes through the field winding into the external circuit.

Series-Working of Dynamo-Electric Machines.—Such a coupling of several dynamo-electric machines as will deliver in series the current supplied by them.

Series-Wound Field.—The field of a dynamo in which the armature current passes through the magnetizing coil.

Series-Wound Laminated Synchronous Motor.—A series-wound synchronous motor provided with a laminated core.

Series-Wound Motor.—A motor provided with a series-wound field.

Serrated Lightning Arrester.—A term sometimes applied to a saw-tooth lightning arrester.

Service.—A conductor or set of conductors supplying electric energy from electric mains to the premises of a consumer.

Service Block.—(1) A block connected with service wires. (2) A block for supporting and connecting service wires.

Service Conductors.—Service wires.

Service Line.—(1) A service wire. (2) In telephony, a line or circuit connecting a switchboard with a subscriber.

Service Tube.—A tube provided for the introduction of service wires.

Service Wires.—(1) The wires which lead into a building and which are connected to the supply mains or supply circuit. (2) The wires through which service is given to a consumer. (3) Delivery wires.

Serving Mallet.—A tool employed for placing the tarred yarn serving on a cable splice.

Serving of Cable.—The bedding of tape, yarn, jute or compound in a cable as distinguished from the core or the sheathing.

Serving Tool.—A tool employed in placing the serving on a cable.

Seven-Point Jacks.—In a multiple telephone switchboard, jacks having each seven different points of contact.

Sextant.—An optical device consisting of a fixed and movable mirror, employed for measuring the angular distance between any two objects.

Sextaplex Telegraph.—A general term embracing the apparatus used in sextaplex telegraphy.

Sextaplex Telegraphy.—A system of telegraphy whereby six distinct messages can be simultaneously transmitted over the same line, three in one direction and three in the opposite direction.

Sextaplex Transmission.—Transmitting intelligence by means of sextaplex telegraphy.

Sextipolar.—Possessing six poles.

Sextipolar Dynamo.—A dynamo possessing a sextipolar field.

Sextipolar Field.—A field produced by six magnet poles.

Sextuple Telegraph.—A general term for the apparatus employed in sextuple telegraphy.

Sextuple Telegraphy.—A system of telegraphic communication in which six separate messages are simultaneously sent over a line in the same direction.

Sextuple Transmission.—The transmission of intelligence by sextuple telegraphy.

Sextuply Re-Entrant.—An armature provided with six separate conducting paths or windings, each of which is independently re-entrant.

Shackle Insulator.—A term applied to any form of insulator used for shackling a wire, as distinguished from an insulator which merely supports a wire.

Shackling a Wire.—(1) Inserting an insulator between the two ends of a cut wire.

(2) Securing the end of a telegraph or telephone wire to a shackle.

Shaded.—(1) Cut off or screened from the effects of an electro-static or magnetic field. (2) Screened.

Shaded-Pole Motor.—An alternating-current motor in which the rotary effort is obtained by placing short circuited coils on a portion of the polar faces.

Shade-Holder.—A ring or circle clamped to the socket of an incandescent lamp for supporting a shade.

Shading Coil of Alternating-Current Motor.—A conducting coil or loop covering part of one or more poles in an alternating-current motor, for the purpose of retarding the magnetic flux through that portion of the pole, and thereby exerting a tangential drag on the armature.

Shadow, Electric.—A term sometimes used for molecular shadow.

Shadowgram.—A term sometimes used for radiograph. (Not in general use.)

Shadowgraph.—A word frequently used for radiograph.

Shadow Photometer.—A photometer in which the intensity of the light to be measured is estimated by a comparison of the distance at which it and the standard light produce shadows of the same intensity.

Shallow-Water Submarine Cable.—A submarine cable intended for use in shallow water, where the cable is apt to be injured by friction against a rocky bottom, and therefore provided with heavier armor than a deep-sea cable.

Shear.—A strain consisting of an extension in one direction combined with an equal compression perpendicular thereto.

Shearing Stress.—A stress producing a shear.

Sheathing of Cable.—The armor or protecting covering employed for surrounding the core of a cable.

Sheathing Wires.—The metallic wires which form the armor of a submarine cable.

Shed of Insulator.—A petticoat or inverted cone of a telegraph insulator.

Sheer.—The curve which the line of ports or the deck of a ship presents to the eye, when observed from one side.

Sheet Lightning.—A variety of lightning flash, unaccompanied by thunder audible to an observer, in which the surfaces of clouds are illumined.

Shell of Arc-Lamp.—The outside casing of an arc-lamp.

Shell of Commutator.—A term sometimes employed for the commutator form, separated from its shaft.

Shell of Fixture.—A light ornamental metallic casing covering some part of an electrolier.

Shell Transformer.—(1) A transformer whose primary and secondary coils are laid on each other, and the iron core is then wound through and over them, so as to completely enclose them. (2) A form of iron-clad transformer.

Shellac.—A resinous substance obtained from the roots and branches of certain tropical plants, which possesses high insulating powers, and high specific inductive capacity.

Shifting Magnetic Field.—(1) A magnetic field whose lines of magnetic force are changing position with respect to the axis of the magnet pole from which they emanate. (2) A rotary magnetic field.

Shifting of Phase of Alternating Current.—In an alternating-current circuit the changes in the phase relation of current strength to impressed E. M. F. depending upon variations in the frequency or in the impedance.

Shifting of Spot of Light.—Any movement of a spot of light on a scale causing that spot to move away from its true zero position, produced by causes other than those acting during the proper operation of the instrument.

Shifting Zero.—(1) A zero that changes or shifts its position. (2) A false zero in measuring instruments.

Ship Dynamometer.—A dynamometer employed on board a cable ship for the purpose of indicating the strain on a grappling rope or on a cable.

Ship Return-Circuit System.—A name applied to a single-wire system or form of circuit in which the hull of the ship forms the return wire.

Shock.—(1) Objectively, a concussion or blow. (2) Subjectively, a violent nervous stimulus.

Shock, Electric.—A physiological shock produced in an animal by an electric discharge.

Shoe of Contact for Street Railway.—The metallic contact piece which rubs against a surface rail or conduit rail in a street railway system.

Shoe Plug.—A form of sliding contact-plug for insertion in a jack of a telephone switchboard.

Shore-End of Telegraphic Cable.—(1) A shallow-water section of submarine cable. (2) The end of a submarine cable landed on a shore.

Short Arc System of Electric Lighting.—A system of electric lighting in which short voltaic arcs are maintained between carbon electrodes.

Short Circuit.—(1) A shunt or by-path of negligible or comparatively small resistance, placed around any part of an electric circuit through which so much of the current passes as to virtually cut out the parts of the circuit to which it acts as a shunt. (2) An accidental direct connection between the mains or main terminals of a dynamo or system producing a heavy overload of current. (3) To cut out of circuit by a short conductor. (4) To accidentally produce a short circuit.

Short-Circuit-Key.—A key which in its normal position short-circuits a galvanometer, or other device with which it is connected.

Short-Circuited.—(1) Placed on a short-circuit. (2) Cut out by means of a short-circuit.

Short-Circuited Conductor.—A conductor which has a short-circuit established past it.

Short Circuiting.—(1) Cutting out of circuit by means of a short-circuit. (2) Establishing a direct connection between the terminals of a source or device, or between mains connected to them.

Short-Circuiting a Dynamo-Electric Machine.—(1) Cutting out the external circuit of a dynamo by means of a short-circuit. (2) Connecting the poles or terminals of a dynamo by a circuit of negligibly small resistance. (3) Greatly overloading a constant-potential machine, and underloading a constant-current machine.

Short-Circuiting Plug.—(1) A plug which when inserted in its receptacle short-circuits the device connected therewith. (2) A plug employed in short-circuiting a coil or other resistance.

Short-Closed Circuit.—In a series dis-

- tribution circuit, the condition of having short-circuited devices, as distinguished from a long-closed circuit from which all short circuits have been removed.
- Short-Coil Magnet.**—A magnet whose magnetizing coil consists of a few turns of short thick wire.
- Short Connection of Two-Circuit Gramme-Winding.**—A form of Gramme winding in which the circuits from brush to brush consist of conductors influenced by all the poles, so that the E. M. F.'s generated in the two circuits are necessarily equal.
- Short-Connection Two-Circuit Armature Winding.**—(1) Such a two-circuit winding that in each circuit between the brushes electromotive forces are induced by each and all the poles of the field frame. (2) Such a type of two-circuit winding as connects coils together lying in adjacent fields.
- Short-Core Electro-Magnet.**—An electro-magnet provided with a short core.
- Short-End of Quadruplex Battery.**—The end of a quadruplex battery, the smaller portion of which is always in circuit, as opposed to the end of the extra battery thrown in circuit by the depression of the increment key.
- Short-Shunt Compound-Winding.**—A compound winding of a dynamo-electric machine in which the shunt coil is connected directly, or through resistance, with the armature brushes, as distinguished from a long-shunt compound-winding.
- Short-Shunt Compound-Wound Dynamo-Electric Machine.**—A compound-wound dynamo whose field-magnet coils form a shunt to the armature only, as distinguished from a shunt to the armature and series coils combined.
- Short-Sightedness.**—(1) The condition of the eye in which distinct images are formed of those objects only which are near to the eye. (2) Myopia. (3) The condition of sight pertaining to an elongated eyeball.
- Short Timber.**—A term applied to timber that has been improperly subjected to preservative processes, and has thereby been rendered brittle.
- Short Wire Repeater.**—A repeater between a duplex or quadruplex and a branch office wire.
- Shower-Bath, Electric.**—A device for carrying an electric charge to the body of a patient by the falling water.
- Shunt.**—An additional, or by-path established for the passage of an electric current or discharge.
- Shunt.**—To establish an additional, or by-path for the passage of an electric current or discharge.
- Shunt-and-Separately-Excited Dynamo-Electric Machine.**—A compound-wound dynamo in which the field is excited both by means of a shunt to the armature circuit, and by a current produced by a separate source.
- Shunt Bell, Electric.**—An electric bell whose magnetizing coils are connected to the line wire in shunt.
- Shunt Breaking Resistance.**—A resistance for insertion in the field of a shunt dynamo, before breaking its circuit, to prevent the production of a dangerously powerful induced pressure.
- Shunt-Circuit.**—(1) A derived circuit. (2) A branch or additional circuit, provided in any part of a circuit, through which the current branches or divides, part flowing in the original circuit and part through the new branch or shunt. (3) A circuit for diverting or shunting a portion of the current.
- Shunt Coil.**—A coil placed in a shunt circuit.
- Shunt Dynamo.**—A shunt-wound dynamo-electric machine.
- Shunt-Field Terminals of Motor.**—The terminals of the shunt field coils of an electric motor.
- Shunt for Ammeter.**—(1) A shunt coil connection in multiple with the coils of an ammeter for the purpose of changing the value of the readings. (2) A reducteur.
- Shunt Spool.**—A spool or coil of insulated wire placed in a shunt circuit.
- Shunt Street-Car Motor.**—A shunt-wound car motor.
- Shunt Ratio.**—(1) The ratio existing between a shunt and the circuit it shunts. (2) The ratio existing between the total current strength and the current strength in the branch to which the shunt is applied.
- Shunt Rheostat.**—A rheostat placed in a shunt-circuit.
- Shunt Turns of Dynamo.**—The ampere turns in the shunt circuit of a shunt-wound or compound-wound dynamo.
- Shunt Winding.**—A term sometimes employed for the shunt field coils on a shunt-wound dynamo or motor.
- Shunt-Wound Dynamo-Electric Machine.**—A dynamo-electric machine whose field-magnet coils are placed in

- shunt with the armature circuit, so that only a portion of the current generated passes through the field-magnet coils, but all the difference of potential of the armature acts at the terminals of the field circuit.
- Shunt-Wound Field.**—The field of a dynamo in which the field-magnet coils are placed in shunt with the armature and external circuit.
- Shunt-Wound Motor.**—A motor whose field-magnet coils are placed in shunt to the armature circuit.
- Shunted.**—Provided with a shunt.
- Shunting.**—Providing with a shunt.
- Shunting Air-Gap.**—(1) An air-gap in a circuit placed around a galvanometer or other instrument, for the purpose of protecting it from the effects of a powerful disruptive discharge. (2) An air-gap shunt in a magnetic circuit.
- Shutter Apparatus.**—In a system of visual telegraphy, an apparatus for suddenly displaying and obscuring a light by means of hand-controlled shutters.
- Shutter Indicator Armature.**—The armature of an electro-magnet so arranged that when released it displays an indicator on an annunciator.
- Shuttle Armature.**—(1) A variety of drum armature in which a single coil of wire is wound in an H-shaped groove formed in a bobbin-shaped core. (2) The old form of Siemens' armature.
- Shuttle-Wound Armature.**—An armature whose coils are placed on its core by first winding the wire on a shuttle and passing the same through the opening or gap provided for the coil.
- Side A of Quadruplex Table.**—That side of a quadruplex system which is worked by means of reversed currents.
- Side B of Quadruplex Table.**—That side of a quadruplex system which is worked by means of strengthened currents.
- Side-Bar Suspension of Motor.**—In a street-railway car truck, a method of supporting the motors which consists in employing a pair of bars or light girders mounted on springs parallel to the side frames and supporting the motors from these bars.
- Side Bracket.**—A particular form of single insulator bracket.
- Side Commutator.**—The commutator of a dynamo-electric machine placed on the side of the revolving armature.
- Side Current.**—A term applied by Hertz to the current produced in the side circuit of a micrometer.
- Side Flash.**—A sparking or lateral discharge taking place from the sides of a conductor through which an impulsive rush of electricity is passing.
- Side-Lights, Electric.**—Red or green lanterns placed on permanent fixtures on either side of a ship.
- Side of Three-Wire System.**—(1) A term applied to the positive or negative conductors or leads in the three-wire system of distribution. (2) The positive or the negative half of a three-wire system.
- Side Pole.**—A trolley-wire pole mounted at the side of a track as distinguished from a central pole.
- Side Pole Line.**—An aerial line supported from poles placed on the side of a street or road, as distinguished from a centre pole line or from one supported from poles placed in the centre of the street or road.
- Side-Pole Trolley-Line Construction.**—A method for the suspension of aerial trolley lines in which the trolley and feed wires are suspended from poles placed on one side of the street or road.
- Side Suspension of Motor.**—A side-bar suspension of a motor in a truck.
- Side Telegraphic Repeater.**—A telegraphic repeater which operates adjacent circuits from a main line.
- Sides of Three-Wire System.**—(1) The portions of a three-wire system which have respectively positive and negative potentials. (2) The positive and negative portions of a three-wire system.
- Siderial.**—Of or pertaining to the stars.
- Sidero-Magnetic.**—A term proposed for ferro-magnetic.
- Siemens Armature Electro-Magnetic Bell.**—A form of electro-magnetic bell, the movements of whose armature are obtained by the reversal of polarity that occurs when alternating currents are passed through a single-coil Siemens armature.
- Siemens Differential Voltmeter.**—A form of voltmeter employed by Siemens for determining the resistance of the platinum spiral used in his electro-pyrometer.
- Siemens Electro-Dynamometer.**—A form of galvanometer employed for the measurement of electric currents.
- Siemens Electro-Pyrometer.**—An apparatus for the determination of temperature by the measurement of the electric resistance of a platinum wire exposed to the source of heat, the temperature of which is to be measured.

Siemens-Halske Voltaic Cell.—A zinc-copper couple whose elements are employed with dilute sulphuric acid and a saturated solution of copper sulphate respectively.

Siemens Water Pyrometer.—A pyrometer employed for determining the temperature of a furnace or other intense source of heat, by the increase in the temperature of a known weight of water to which a metal cylinder of a given weight has been put, after exposure for a given time to the source of heat to be measured.

Signal Arm.—A semaphore arm.

Signal-Service System for Electric Railroad.—A system of electric signals used on railroads for ascertaining the condition of the road, sending instructions to engineers, and conveying intelligence generally from stations along the road to running trains.

Sight-Feeding Oiler.—A glass oil-cup which permits the visible feeding of lubricating oil to the journal bearings.

Signature.—In telegraphy, a name of the sender of a message as it appears upon the same.

Silence Telephone Cabinet.—A long-distance telephone cabinet.

Silent.—A switch device for preventing the action of an electric alarm by short-circuiting it.

Silent Discharge.—A name sometimes given to a convective discharge, in order to distinguish it from the more noisy disruptive discharge.

Silhougraph.—A word proposed for radiograph.

Silver Bath.—An electrolytic bath containing a readily electrolyzable salt of silver, and a plate of silver acting as the anode, placed in the liquid near the object to be coated which forms the cathode.

Silver Chloride Voltaic Cell.—A zinc-silver couple immersed in electrolytes of sal-ammoniac or common salt, and silver chloride, respectively.

Silver-Palladium Alloy.—An alloy of silver with palladium and other metals, employed for the hair-springs, escapements and balance-wheels of watches, on account of its non-magnetic properties.

Silver Plating.—Covering the surfaces of the baser metals with an adherent coating of silver by the electric current.

Silver Voltmeter.—A voltmeter in which the quantity of electricity passing is determined by the weight of silver deposited.

Silvered Plumbago.—Powdered plumbago covered with metallic silver, for use in the metallization of objects to be electro-plated.

Silurus Electricus.—The electric eel.

Similar.—Conductors in the secondary winding of an induction machine which are similar to each other in respect to the magnitude of their induced electromotive forces at any instant, and symmetrically disposed relatively to the rotating poles.

Simple Alternating-Currents.—(1) Sinusoidal-alternating currents. (2) Simple-harmonic currents.

Simple Arc.—A voltaic arc formed between two electrodes.

Simple Circuit.—A term sometimes employed for a circuit containing a single electric source and a single electro-receptive device.

Simple Electric Candle Burner.—A plain-pendant electric burner.

Simple-Harmonic Currents.—(1) Currents whose flow is variable both in strength and duration, and in which the quantity of electricity passing by any section of conductor may be represented by a simple-harmonic curve. (2) A current of such a nature that the continuous variation of the flow of electricity past any area of cross-section of the conductor, or the continuous variations in electromotive force, may be expressed by a simple-harmonic curve.

Simple-Harmonic Curve.—The curve which results when a simple-harmonic motion in one line is compounded with uniform motion in a straight line at right angles thereto.

Simple-Harmonic Electromotive Forces.—Electromotive forces which vary in such a manner as to produce simple-harmonic currents; or, electromotive forces whose variations can be correctly represented by a simple-harmonic curve.

Simple-Harmonic Motion.—(1) Motion which repeats itself at regular intervals in one line, taking place backwards or forwards, and which is the orthogonal projection of the path of a point moving uniformly in a plane circle upon a diameter of the circle. (2) Motion which is a simple-periodic function of the time. (3) Simple-periodic motion.

Simple-Harmonic Variation.—A variation of current or electromotive force which takes place in accordance with simple-harmonic law.

Simple Immersion.—A term sometimes employed for an electrolytic deposit obtained by merely dipping a metal in a solution of a metallic salt.

Simple Magnet.—A simple magnetized bar.

Simple Magnetic Shell.—A magnetic shell whose strength is everywhere the same.

Simple-Periodic Currents.—A term sometimes used for simple-harmonic currents.

Simple-Periodic Curve.—A simple-harmonic curve.

Simple-Periodic Electromotive Force.
A simple-harmonic electromotive force.

Simple-Periodic Motion.—Simple-harmonic motion.

Simple-Periodic Variation.—Simple-harmonic variation.

Simple Radical.—(1) An unsaturated atom with its bond or bonds free. (2) A single unsaturated atom, as distinguished from an unsaturated group of atoms.

Simple Rigidity.—(1) In an isotropic body the ratio of shearing stress to the resulting shear. (2) Resistance to shearing. (3) In an isotropic body the edges of a unit cube to which tangential shearing stresses are applied, the ratio of the tangential force to the angular distortion effected in the cube.

Simple Shunt.—A coil arranged as a shunt, and unprovided with an iron core.

Simple-Sine Motion.—A term sometimes employed for simple-harmonic motion.

Simple Voltaic Cell.—A term sometimes used for a single-fluid cell.

Simplex Telegraph.—A general term embracing the apparatus employed in simplex telegraphy.

Simplex Telegraphy.—A system of telegraphy in which a single message only can be sent over the line wire.

Simplex Working.—(1) Transmitting messages by simplex telegraphy. (2) A word sometimes employed for simple telegraphic transmission.

Sims-Edison Torpedo.—A special form of torpedo in which electricity is both the propelling and directing power, but the electric source is situated outside the torpedo, and is connected with the same by a light cable.

Sine Galvanometer.—A galvanometer whose deflecting coil is placed in a vertical plane movable about a vertical axis, so that it can be made to follow the magnetic needle in its deflections.

Sine Law.—(1) A law of magnitude de-

finied by the sines of angles. (2) A magnitude which follows the sines of successive angles.

Single Brush-Rocker Arm.—A device by means of which a single pair of brushes are so situated on a dynamo or motor as to be capable of being readily shifted into the desired position on the commutator cylinder.

Single-Brush Yoke.—A term sometimes used for single brush-rocker arm.

Single-Circuit.—An undivided circuit.

Single-Contact Carbon Telephone.—A form of microphonic telephone transmitter, in which a single contact is employed.

Single-Contact Key.—Any key which makes a single contact only.

Single-Cord Multiple-Telephone Switchboard.—(1) A multiple telephone switchboard employing a single conducting cord in establishing connections. (2) A multiple-telephone switchboard in which the circuits are all ground-return-circuits, and the subscribers' jacks are all connected in series.

Single-Cord Switchboard.—(1) A telephone switchboard in which an inter-connection between two subscribers is effected through a single cord. (2) A telephone switchboard in which each line terminates in a plug.

Single-Cord Telephone Switchboard.
A telephone switchboard employing single conducting cords.

Single-Cup Insulator.—An insulator consisting of a single inverted cup.

Single Curb.—A device for increasing the speed of telegraphic signalling by ridding the line of its previous charge by means of a single reversed current sent through it after each signal, before connecting to the ground, as distinguished from a double curb in which a succession of two reversed currents follow each signal.

Single-Curb Signalling.—Signalling by means of a single curb.

Single-Current Signalling.—Signalling by means of makes or breaks in the circuit of a single current.

Single-Current Closed-Circuit Signalling.—A method of telegraphic signalling in which the line circuit is normally closed, being only broken by the sending operator, while the current in the circuit has only one direction.

Single-Current Key.—A key employed in single-current signalling.

Single-Current Open-Circuit Signal-

- ling.**—A method of telegraphic signalling in which the main-line batteries are fixed at each station, and are in circuit only when signalling.
- Single-Current Telegraphic Working.**—A term sometimes used for single-current signalling.
- Single-Current Translator.**—A telegraphic translator suitable for use in single-current working.
- Single-Curve Suspension.**—(1) A suspension suitable for the support of a trolley wire at a single curve in the line, or single-track curve. (2) A form of suspension having a single curved holder or support.
- Single-Curve Trolley Hanger.**—(1) A hanger supporting a single curve wire or single-track curve wire. (2) A trolley hanger supported by a single curved holder.
- Single-Curve Trolley-Suspension.**—(1) Suspension of a trolley wire by a single-curve trolley-hanger. (2) A single-track trolley-suspension at a curve in the track.
- Single-Coil Field Dynamo.**—A dynamo whose magnetic field is obtained from a single magnetizing coil.
- Single Field-Coil Multipolar Dynamo.**—A multipolar dynamo having a single field coil on a single core provided with a plurality of polar projections.
- Single-Fluid.**—Pertaining to the single-fluid hypothesis of electricity or magnetism.
- Single-Fluid Hypothesis of Electricity.**—A hypothesis which endeavors to explain the cause of electrical phenomena by the assumption of the existence of a single electric fluid.
- Single-Fluid Voltaic Cell.**—A voltaic cell in which but a single fluid or electrolyte is used.
- Single-Focus X-Ray Tube.**—An X-ray tube suitable for use in connection with pulsatory currents, and provided with a single deflecting plate or anticathode opposite the cathode.
- Single-Line Repeater.**—In telegraphy, a repeater from a single circuit into another.
- Single-Liquid Voltaic Cell.**—A single-fluid voltaic cell.
- Single-Loop Armature.**—An armature consisting of a closed conducting circuit containing a single loop, so placed as to be capable of revolving in a magnetic field, as to cut its magnetic flux.
- Single-Magnet Dynamo-Electric Machine.**—A term sometimes used for a single field-coil dynamo.
- Single-Needle Telegraphy.**—A system of telegraphy in which the transmitted signals are received by the movements of a vertical needle suitably suspended before a dial.
- Single-Pair Brush-Rocker.**—A term sometimes used for single-pair brush yoke.
- Single-Pair Brush Yoke.**—A device for so holding a single pair of collecting brushes of a dynamo-electric machine that they can be readily moved or rotated on the commutator cylinder.
- Single-Pair Yoke.**—A single-pair brush yoke.
- Single Peg.**—A peg provided with but a single contact.
- Single Phase.**—(1) Uniphase. (2) Monophase. (3) Pertaining to ordinary alternating currents in a simple alternating-current system as distinguished from multiphase currents.
- Single-Phase Alternating Current.**—A uniphase alternating current.
- Single-Phase Alternator.**—An alternator capable of producing simple or single-phase currents.
- Single-Phase Armature Windings.**—Windings employed on the armature of a single-phase alternator.
- Single-Phase Armature Windings.**—Armature windings of single-phase generators.
- Single-Phase Asynchronous Motor.**—A single-phase alternating-current motor capable of running otherwise than in synchronism with the current supplied to it from the circuit.
- Single-Phase Bar - Armature Windings.**—Such a bar armature winding of an alternator as is capable of producing single-phase currents.
- Single-Phase Dynamo.**—A single-phase alternator.
- Single-Phase Generator.**—A single-phase alternator.
- Single-Phase Motor.**—A uniphase motor.
- Single-Phase Induction Motor.**—An induction motor operated by uniphase currents.
- Single-Phase Induction Motor.**—An induction motor operated or intended to be operated on a single-phase alternating-current circuit.
- Single-Phase Synchronous Motor.**—A synchronous motor capable of being operated by uniphase currents.

- Single-Phase Transformer.**—A transformer suitable for supplying or transforming single-phase currents.
- Single-Phase Winding.**—A single-phase armature winding.
- Single-Phaser.**—(1) An alternating-current generator of single-phase currents. (2) A uniphaser.
- Single-Pole Cut-Out.**—A cut-out by means of which the circuit is broken or cut in one of the two leads only.
- Single-Pole Safety-Fuse.**—A single pole cut-out operated by a safety fuse.
- Single-Pole Switch.**—A switch which opens or closes a circuit at one of its leads only.
- Single-Pole Telephone Receiver.**—(1) A bar-magnet telephone with a coil on one end of the bar. (2) A telephone receiver in which only one magnetic pole is presented to the diaphragm, as distinguished from a receiver in which a pair of poles, each surrounded by a coil, is presented to the diaphragm.
- Single-Pole Telephone Switch.**—A single-pole switch employed on a telephone circuit.
- Single Pull-Off.**—(1) A trolley pull-off supported on a single-curve holder. (2) A single-curve pull-off. (3) A trolley pull-off on a single-track curve.
- Single-Reduction.**—(1) Having but a single gear wheel for reducing speed. (2) A gearing in which but a single reduction of speed takes place as opposed to a double gearing in which two separate reductions are effected.
- Single-Reduction Street-Car Motor.**—A street-car motor which requires a single reduction gear connected with the car axle to reduce the motion of the car axle as opposed to a motor geared with the car axle through two successive gear wheels and therefore one intermediate shaft.
- Single-Reflection Tube.**—A term sometimes applied to an X-ray tube containing but a single deflecting plate or anticathode.
- Single-Shackle Insulator.**—(1) A form of insulator, employed in shackling a single wire. (2) A form of single shackle to which two wires can be fastened at different points and left insulated.
- Single-Shed Insulator.**—An insulator provided with a single inverted cup.
- Single-Stroke Electric Bell.**—An electric bell that gives a single stroke only for each closure of the circuit.
- Single-Throw Switch.**—A switch having but two positions, one for opening, and the other for closing the circuit it controls, as distinguished from a double-throw switch.
- Single-Touch.**—A phrase sometimes employed for magnetization by single touch.
- Single-Track Bracket Trolley-Suspension.**—A form of single-track trolley-wire suspension, in which a bracket is supported from a pole placed on one side of the street.
- Single-Trolley System.**—A trolley system in which a single conducting over-head wire is employed, the track and ground being used for a return.
- Single-Trolley System Electric-Railroad.**—An electric railroad operated by a single trolley.
- Single-Truck Car.**—A car whose body is supported on a single truck.
- Single-Valued Function.**—A function which has only a single value for each value of the variable.
- Single-Wire Cable.**—A cable whose core contains a single conducting wire only.
- Single-Wire Circuit.**—A term sometimes used for a grounded circuit.
- Single-Wire Line.**—A term sometimes used for a single-wire circuit.
- Single-Wire Multiple Telephone Switchboard.**—(1) A single-cord multiple telephone switchboard. (2) A switchboard connecting ground-return subscribers' lines, the jacks of which are all in series in each line.
- Single-Wire Spring-Jack.**—A spring-jack suitable for use in a single-wire switchboard.
- Single-Wire Switchboard.**—(1) A switchboard devoted to the connections of a single line with various sets of apparatus. (2) A telephone switchboard connected to ground-return circuits.
- Single-Wire System for Electric Light Leads.**—A term sometimes employed for a ground-return electric light circuit.
- Single-Wire Telephone Switchboard.**—A form of telephone switchboard connecting ground-return circuits.
- Single-Wound Gramme Ring.**—A Gramme ring provided with a single winding, the number of whose coils is a multiple of the number of poles, and the number of whose commutator segments is equal to the number of poles.
- Single-Wound Multiple-Circuit Mul-**

- tipolar Drum-Armature.**—A drum armature wound for a multipolar field in a single winding and affording a plurality of paths or circuits between its brushes.
- Single-Wound Two-Circuit Drum-Armature.**—A drum armature, wound for a multipolar field, with a single winding and affording two conducting paths or circuits between the brushes.
- Single-Wound Two-Circuit Multipolar Ring-Armature.**—A ring armature wound for a multipolar field, with a single winding, which affords but two conducting paths or circuits between the brushes.
- Single-Wound Wire.**—Wire wound or covered with a single layer of insulating material.
- Singly Re-Entrant Armature-Winding.**—(1) A single-winding which re-enters itself. (2) An armature provided with a single-winding which is re-entrant.
- Singular Polarization.**—A term applied to the polarization of a voltaic cell when the depolarizing current is many times stronger than the primary current.
- Sinistrorsal Helix.**—A sinistrorsal solenoid.
- Sinistrorsal Solenoid.**—A solenoid whose winding is left-handed.
- Sinuuous Current.**—A term sometimes applied to a current flowing through a sinuous conductor.
- Sinusoid.**—A name frequently given to a curve of sines.
- Sinusoidal.**—Of or pertaining to a sinusoid.
- Sinusoidal Alternating Electromotive Forces.**—(1) Alternating electromotive forces whose variations in strength are correctly represented by a sinusoidal curve. (2) Simple-harmonic E. M. F.'s. (3) E. M. F.'s which are simple-harmonic functions of time.
- Sinusoidal Alternator.**—An alternator capable of producing sinusoidal electromotive forces.
- Sinusoidal Currents.**—Simple-periodic currents whose strengths are correctly represented by sinusoids.
- Sinusoidal-Current Circuit.**—A circuit conveying sinusoidal currents.
- Sinusoidal Curve.**—(1) A curve of sines. (2) A sinusoid. (3) A curve which to rectangular co-ordinates has an ordinate at each point proportionate to the sine of an angle proportionate to the abscissa.
- Sinusoidal Flux.**—A flux which varies sinusoidally or according to a simple-harmonic law.
- Sinusoidal Generator.**—A sinusoidal alternator or generator capable of delivering a simple-harmonic E. M. F.
- Sinusoidal Magnetic Flux.**—A sinusoidally varying flux.
- Sinusoidal Magnetomotive Force.**—A magnetomotive force varying sinusoidally.
- Sinusoidal Variation.**—Such a variation of an electromotive force, current, or flux, as may be correctly represented by a sinusoid.
- Sinusoider.**—A name sometimes given to a sinusoidal alternator.
- Siphon, Electric.**—A siphon in which the stoppage of the flow of the liquid due to the gradual accumulation of air, is prevented by electrical means.
- Siphon Recorder.**—An apparatus for recording in ink on a strip of paper a message received over a cable by means of a jet of ink thrown out from a fine glass tube supported on a fine wire.
- Siphon-Recorder Vibrator.**—A device employed in a siphon recorder to obtain the vibrations required for the ejection of the ink from the siphon by mechanical means instead of by electrical means.
- Siphon Writing.**—A record obtained by means of a siphon recorder.
- Siren.**—An acoustic apparatus employed for measuring the frequency of sound waves.
- Six-Pole Dynamo-Electric Machine.**—A sextipolar dynamo.
- Six-Wire System.**—A system of distribution similar in general to the three-wire system, in which five dynamos are connected to six conductors or leads.
- Six-Wire Triphase System.**—A system for the production of triphase currents, in three separate circuits, each having two wires.
- Skew Adjustment of Carbons in Arc-Lamps.**—The adjustment of the carbons of an arc lamp by means of which the positive carbon is placed a short distance in front of, but out of the vertical line with the negative carbon.
- Skiagraph.**—A word proposed for radiograph. (Not in general use.)
- Skiasmogram.**—A word proposed for radiograph. (Not in use.)
- Skidding of Car Wheels.**—A term expressing the sliding of the wheels of a car in place of their proper rolling motion.

- Skin Currents.**—A term applied to rapidly alternating currents which are limited to the surface of a conductor.
- Skin Electromotive Force.**—The E. M. F. which is active in producing the skin effect in a conductor.
- Skin Effect.**—The tendency of rapidly alternating currents to avoid the central portions of solid conductors and flow, for the greater part, through the superficial portions.
- Skipping of Pointer of Telegraph Instrument.**—In a dial telegraph, the failure of the dial to point to the letter intended, and caused by its skipping one or more of the letters.
- Skodogram.**—A term proposed for radiograph. (Not in use.)
- Skotograph.**—A term proposed for radiograph. (Not in use.)
- Slack.**—Excess.
- Slack Cable.**—Extra cable, or cable paid out in excess of the distance covered, in order to permit of the subsequent recovery of the cable without undue strain, and also to allow of its accommodating itself to irregularities in the contour of the sea-bottom.
- Sled.**—A sliding contact drawn after a moving railroad car through the slotted conduit containing the wires or conductors from which the driving current is taken.
- Sleeve Joint.**—A junction of the ends of conducting wires obtained by passing them through tubes, and subsequently twisting and soldering.
- Sleeve of Plug.**—A conducting cylinder upon a telephone plug, making contact with the barrel or socket of a telephone jack.
- Slide Bridge.**—A bridge whose proportionate arms are formed of a single thin wire, of uniform diameter and of comparatively high resistance, of some material whose temperature coefficient is low.
- Slide Contact Piece.**—A contact piece in which the circuit is completed by means of a sliding or wiping joint.
- Slide Form of Electric Bridge.**—A slide bridge.
- Slide Resistance.**—(1) A rheostat whose separate resistances or coils are placed in or removed from a circuit by means of a sliding contact. (2) An apparatus employed in telegraphy consisting of a pair of slide rheostats actually subdivided into 100 parts each, but forming jointly a rheostat virtually subdivided into 10,000 parts.
- Slide Switchboard.**—A telephone switchboard in which the connections are made by sliding contacts.
- Slide Wire.**—A wire of uniform diameter employed in Wheatstone's electric bridge for the proportionate arms of the bridge.
- Sliding Bed-Plate.**—A bed-plate of a belt-driven dynamo, motor, or other similar apparatus, provided with means for moving it, so as to tighten the belt.
- Sliding Contact.**—A contact connected with one part of a circuit that closes or completes that circuit by being slid over a conductor connected with another part of such circuit.
- Sliding Contact-Key.**—A key employed in the slide form of Wheatstone's bridge to make contact with the sliding wire.
- Sliding Joint.**—An expansion joint.
- Slings.**—Bright copper wires employed for hanging an object to be electro-plated to the negative rod in the depositing vessel.
- Slinging Wires.**—Erecting wires on aerial poles.
- Slip.**—To release a buoy, rope, anchor etc., in cable work.
- Slip of Induction Motor.**—The proportional difference between the speed of the rotary magnetic field which drives the motor and the speed of the rotor.
- Slip of Rotor.**—The proportional difference between the speed of a rotary magnetic field and the speed of the rotor.
- Slip Thimble.**—In cable work, a device for readily disengaging a buoy from the side of a vessel or from its buoy rope.
- Slippage.**—The ratio, subtracted from unity, of the speed of a rotor divided by the speed of a rotatory magnetic field.
- Slipping of Belt.**—The loss of speed of a revolving belt on its pulley due to slipping.
- Slope of Magneto-Motive Force.**—A term sometimes used for magnetizing force.
- Slope of Potential.**—A phrase sometimes used for drop of potential.
- Slots on Armature Core.**—Slots or grooves provided in an armature core for the reception of the armature coils.
- Slot-Wound Armature.**—(1) An armature in which the windings are buried in slots. (2) An ironclad armature.
- Slotted Armature.**—(1) An armature provided with slots or grooves for the reception of the wires. (2) An iron-clad armature.
- Slotted Armature-Core.**—An armature core provided with longitudinal grooves.

Slotted Conduit.—An underground conduit provided with a slot extending to the surface of the road-bed, through which a travelling conductor can carry off the current from one or more conductors supported in the conduit.

Slow-Speed Electric Motor.—(1) An electric motor which is capable of efficient operation at a comparatively slow speed. (2) A motor designed to run at a comparatively slow speed.

Slow-Speed Generator.—A generator designed to be run at a slow speed.

Sluggish Magnet.—A magnet that acquires or loses its magnetism sluggishly.

Smashing Point of Incandescent Electric Lamp.—Such a period in the life of an incandescent lamp which has become blackened, when it will be more economical to break the lamp, or remove it from the circuit and replace it by a new one, than to continue its operation.

Smee Voltaic Cell.—A zinc-silver couple employed in connection with an electrolyte of dilute sulphuric acid.

Smelting of Phosphorus, Electric.—The electric separation of phosphorus from any of its compounds.

Smooth-Body Generator.—A dynamo or generator provided with a smooth-core armature.

Smooth-Core Armature.—(1) An armature which presents a continuously smooth cylindrical surface before the armature coils are wound on it. (2) A surface-wound armature as distinguished from an iron-clad armature.

Snap Switch.—A switch in which the transfer of the contact points from one position to another is accomplished by a quick motion obtained by the operation of a spring.

Snap Welding of Rails.—A welding joint for a rail bond in which the rails are clamped at their short projections, the ends heated as rapidly as possible and then firmly squeezed together when the welding temperature has been reached.

Snapper.—A device in a sounding-lead consisting of a pair of metallic jaws which are open when the lead is lowered but which automatically close when the sea bottom is reached, for the purpose of securing samples of the sea bottom.

Snapper Sounder.—A mechanical device for producing, by the flexure of a spring, sounds corresponding to Morse characters as heard from a Morse sounder.

Sneak Current.—(1) A relatively weak current accidentally introduced into a

telephonic or telegraphic circuit, which would do no immediate harm, but which continuing to circulate in a bell or annunciator coil would generate enough heat in a comparatively short time to burn it out. (2) A current of sufficient strength to be dangerous if maintained, but insufficiently strong to melt the usual safety fuses.

Sneak-Current Arrester.—A sneak-current protector or coil.

Sneak-Current Coil.—A coil of German-silver wire inserted in a telephone circuit to become sufficiently heated by a sneak-current, or current of dangerous strength, to melt a drop of fusible metal placed within it, and thereby cut the telephone apparatus out of circuit.

Sneak-Current Protector.—A form of protector in which a fine fusible wire is inserted between the end of a line and the instruments.

Snow-Sweeper, Electric.—A form of snow-sweeper operated by means of an electric motor.

Soakage.—A term sometimes employed for residual charge.

Soaking-In.—A term sometimes employed for the gradual penetration of an electric charge through a dielectric.

Soaking-Out.—A term sometimes employed by telegraphers to represent the gradual discharge which occurs after the first discharge when a charged cable conductor is put to earth.

Socket.—(1) In a telephone switchboard a jack or receptacle for a plug. (2) The barrel of a jack, as distinguished from the contact of the jack placed behind the barrel.

Socket-Base.—A lamp base provided with means for ready introduction into a lamp socket.

Socket for Electric Lamp.—A support for the reception of an incandescent lamp.

Socket Key.—A key provided in a lamp socket for lighting or extinguishing the lamp.

Socket Lamp.—A lamp provided with a socket.

Socket Switch.—A socket key.

Soft-Drawn Copper Wire.—Copper wire that is softened by annealing after being drawn.

Soft Porous Cell.—A soft baked porous cell, whose use in a voltaic cell renders its internal resistance comparatively low.

Softness.—That property of a body in

- virtue of which it is readily scratched, or its molecules displaced.
- Solar Telegraph.**—A name sometimes applied to a heliograph.
- Solarization.**—A term used in photography for the effect produced by exposure to the sun.
- Solder Ear.**—An ear or hanger in a trolley system to which the trolley is secured by solder.
- Soldering, Electric.**—A process for obtaining metallic joints, in which electrically generated heat is employed to melt the solder.
- Soldering Flux.**—Any chemical suitable for use in connection with solder to cleanse the surfaces of the articles to be soldered.
- Soldering Furnace.**—A portable furnace for melting solder and heating soldering irons.
- Solenoid.**—(1) A cylindrical coil of wire whose convolutions are circular. (2) An electro-magnetic helix. (3) Theoretically, a series of coaxial conducting circles placed side by side.
- Solenoid Core.**—A core, usually of soft iron, placed within a solenoid and magnetized by the magnetic flux of the magnetizing current.
- Solenoid Galvanometer.**—A galvanometer whose needle consists of a solenoid core.
- Solenoidal.**—Of or pertaining to a solenoid.
- Solenoidal Blow-Out.**—A magnetic blow-out in which the magnet is a solenoid devoid of an iron core.
- Solenoidal Distribution.**—A space distribution of a vector quantity devoid of convergence.
- Solenoidal Distribution of Magnetism.** A term sometimes applied to such a distribution of magnetism in a bar that its particles are arranged with their poles in the direction of the length of the bar, the ends of which are of opposite magnetic polarities, and the extent of whose surface is small as compared with the length of the bar.
- Solenoidal Magnet.**—A magnet possessing a solenoidal distribution of magnetism.
- Solid Angle.**—(1) The opening between three or more planes at their point of common intersection. (2) The area of a portion of spherical surface of unit radius as traced by a central radius vector which traces the outline of the solid angle.
- Solid Arc-Light Carbons.**—(1) Carbon electrodes for arc lights unprovided with a core of softer carbon. (2) A carbon which is of uniform composition throughout as distinguished from a cored carbon.
- Solid-Back Telephone Transmitter.**—A term applied to a form of microphone transmitter, largely employed in long-distance telephony.
- Solid Carbons.**—Solid arc-light carbons.
- Solid Conduit.**—A conduit in which the insulating material is cast or placed around the wires or conductors so that they cannot be removed from the conduit without breaking.
- Solid Depolarizer.**—Any solid substance employed in connection with the negative plate of a voltaic cell for the purpose of effecting its depolarization.
- Solid Thermostat.**—A thermostat whose operation depends on the expansion of a solid, or on the unequal expansion of two different solids.
- Solid Wires.**—Any conductor formed of a single wire, as distinguished from a stranded conductor, or one formed of a number of parallel wires.
- Soluble Electrodes.**—Electrodes employed in metallic electrolysis, made of copper, iron or other metals which are converted into metallic salts during electrolysis.
- Solution.**—A liquid in which a solid, gas or another liquid is dissolved.
- Sonometer.**—A single wire stretched at its ends, provided with a movable bridge for the purpose of determining the relation existing between the frequencies of the successive tones of any gamut.
- Sonometer Interrupter.**—A term sometimes employed in place of electro-dynamic interrupter.
- Sonorescence.**—A word proposed for the sounds produced when a piece of vulcanite, or other solid substance, is exposed to a rapid succession of flashes of light.
- Sonorous.**—Sounding or producing sound.
- Soot Cell.**—In radiophony, a name sometimes given to a carbon cell.
- Sound.**—(1) The sensation produced on the brain through the ear by the vibrations of a sonorous body. (2) The sound waves that are capable of producing a sensation of sound on the brain through the ear.
- Sound Error.**—In telegraphy, an error made by mistaking the sound of a signal, syllable, word or phrase, as distinguished from an error made by mistaking the sight of a written character or word.
- Sound Waves.**—Waves produced in the air or other elastic medium by the vibrations of a sonorous body.

- Sounder Resonator.**—(1) A name sometimes given to a sounder surrounded by a resonant case, for the purpose of increasing the intensity of its sound by resonance. (2) A box-sounding relay.
- Sounding Board.**—An elastic board employed in a stringed musical instrument for the purpose of increasing the intensity of the sounds by resonance.
- Sounding Relay.**—A box-sounding relay.
- Sounding Tube.**—A tube employed in a deep-sea sounding-lead for the purpose of securing a sample of the sea bottom.
- Source, Electric.**—Any arrangement capable of maintaining a difference of potential or electromotive force.
- Southern Light.**—The aurora australis.
- South Magnetic Pole.**—(1) That pole of a magnetic needle which points approximately to the earth's geographical south. (2) The south-seeking pole of a magnetic needle.
- South-Seeking Magnetic Pole.**—The south magnetic pole.
- Spacer.**—In a double-current Morse translator, an electro-magnet in the local circuit, sending zinc, negative, or spacing currents on the circuit to which the current is being delivered.
- Spacing Battery.**—A battery in double-current telegraphy employed to send spacing currents.
- Spacing Current.**—(1) The current employed in automatic telegraphy for the purpose of leaving a space on the recording paper, as distinguished from the marking current, or the current that is intended to record a dot or dash on the paper. (2) In double-current telegraphy, the currents in one direction which effect and correspond to spaces as distinguished from those in the other direction which effect and correspond to marks or signals.
- Spacing of Armature Conductors.**—The pitch of an armature winding.
- Span Cable-Way.**—An overhead cable suspended from poles, and intended for supporting an electric locomotor in a system of electric haulage or telpherage.
- Span Guard-Wire.**—A wire strung across the street over a trolley wire for the purpose of preventing a wire from falling on the trolley wire, as distinguished from running guard wires which overhang and follow a trolley wire along the street.
- Span Wires.**—Wires tightly stretched across a street from pole to pole, for the purpose of supporting trolley wires.
- Span-Wire Hangers.**—The hangers which suspend the trolley wires from the span wires.
- Span-Wire Trolley Line Construction.**—A method for the suspension of an aerial trolley line, in which the trolley and feed wires are suspended from span wires supported on poles placed opposite to one another on each side of the street or road.
- Spanish Spoon.**—A name given to a form of shovel employed for lifting soil out of a hole in the ground excavated for a telegraph pole.
- Spar Torpedo.**—A torpedo attached to the end of a spar and designed to be exploded by percussion against the side of an enemy's vessel when thrust against it.
- "Spare" Machine.**—An extra dynamo, motor or other machine reserved in an installation for use in case of accidental break down.
- Spark Arrester.**—A device for preventing an arc lamp from scattering sparks or particles of incandescent carbon.
- Spark Chronograph.**—A form of electric chronograph in which the record is made of the time of a certain event by means of a spark from a Ruhmkorff or spark coil.
- Spark Coil.**—A coil of insulated wire connected with the main circuit in a system of electric gas lighting, whose extra spark produced on breaking the circuit is employed for electrically igniting gas jets.
- Spark Discharge.**—(1) An electric discharge effected by a spark. (2) A disruptive discharge.
- Spark, Electric.**—A term sometimes applied to a disruptive discharge. (2) The phenomena produced by a disruptive discharge in the air-space or gap through which the discharge passes.
- Spark Gap.**—(1) The air-space or gap through which a disruptive discharge passes. (2) A gap forming part of a circuit between two opposing conductors and filled with air or other dielectric, across which a spark passes when a certain difference of potential has been reached.
- Spark Micrometer.**—A spark gap capable of delicate adjustment and measurement.
- Spark Tube.**—A high-vacuum tube across which the spark from an induction coil will not pass, if the vacuum is sufficiently high.
- Sparkling.**—Discharging by means of disruptive sparks.
- Sparkling Discharge.**—A disruptive discharge.

Sparking Distance.—The distance through which electric sparks will pass across an intervening air-gap.

Sparking of Dynamo-Electric Machine.—An irregular and injurious operation of a dynamo attended with sparks at its collecting brushes.

Sparking Terminals.—(1) The terminals of a spark-gap. (2) The points or ends of a spark-gap.

Sparkless Commutation.—Commutation of a dynamo accomplished without sparking at the brushes.

Spasmodic Governor.—A name given to a form of governor for electric motors, in which the current is automatically cut off in proportion as the work is cut off.

Speaking Battery.—In telegraphy or telephony, the battery employed for speaking or signalling.

Speaking Key.—(1) In telegraphy, a key employed in speaking. (2) A signalling key as distinguished from a testing key.

Speaking Mirror.—A simple form of mirror galvanometer employed in cable telegraphy for the reception of the current impulses or signals.

Speaking Mirror Plug.—A closed tube or plug for insertion into a speaking mirror instrument, and containing a suspended mirror and magnet.

Speaking Switch.—In telegraphy, a switch employed in speaking or signalling.

Speaking Telegraph.—A term sometimes employed for the telephone.

Speaking Telegraphy.—A term sometimes employed for telephony.

Speaking-Tube Annunciator.—An oral annunciator.

Speaking-Tube Mouth-Piece Alarm, Electric.—A mouth-piece for a speaking-tube, so arranged that the movement of a pivoted plate covering the mouth-piece automatically rings an electric bell at the other end of the tube.

Speaking-Tube Telephone System.—A name sometimes employed for a system of telephone communication by means of which a number of offices can be connected without the use of a central switch-board.

Speaking Wire.—In a system of telephony, a wire connecting two exchanges for the purpose of communicating instructions between operators, as distinguished from a wire through which a subscriber may be connected.

Specific Capacity.—Specific inductive capacity.

Specific Conductance.—A term sometimes used for specific conductivity.

Specific Conduction Resistance.—(1) Resistivity. (2) A term sometimes used for specific resistance.

Specific Conductivity.—(1) The particular conductivity of a substance for electricity. (2) The specific or particular resistance of a given length and area of cross-section of a substance, as compared with the same length and area of cross-section of some standard substance. (3) Conductivity with reference to Matthiessen's standard conductivity.

Specific Dielectric Capacity.—A term sometimes employed in place of specific inductive capacity.

Specific Energy.—(1) Volumetric energy. (2) Energy per unit of volume.

Specific Gravity.—The weight of a given volume of a substance, as compared with an equal volume of some standard substance, such as water.

Specific Heat.—The capacity of a substance for heat, as compared with an equal quantity of some other substance taken as unity.

Specific Heat of Electricity.—A term proposed to indicate the analogies existing between the absorption and emission of heat in purely thermal phenomena, and the absorption and emission of heat in thermo-electric phenomena.

Specific Hysteretic Dissipation.—(1) The loss of energy by hysteresis in a particular substance, per unit of volume. (2) The hysteretic loss of energy in a substance under given conditions compared with the similar loss in a standard substance.

Specific Inductive Capacity.—(1) The ability of a dielectric to permit induction to take place through its mass as compared with the ability possessed by a vacuum space of the same dimensions, under precisely the same conditions. (2) The relative power of bodies for transmitting electrostatic stresses and strains, analogous to permeability in metals. (3) The ratio of the capacity of a condenser whose coatings are separated by a dielectric of a given substance, to the capacity of a similar condenser whose plates are separated by a vacuum. (4) The ratio of the permittivity of a substance to the permittivity of vacuum.

Specific Magnetic Capacity.—(1) A term sometimes employed in the sense of magnetic permeability. (2) A word employed for conductivity for magnetic

- flux, in the same sense that specific capacity is conductivity for electrostatic flux.
- Specific Magnetic Conductivity.**—The specific or particular permeability of a substance to magnetic flux.
- Specific Magnetic Inductivity.**—A term sometimes used for specific magnetic conductivity.
- Specific Magnetic Reluctance.**—A term sometimes used for specific magnetic resistance.
- Specific Magnetic Resistance.**—A term sometimes used for reluctivity.
- Specific Magnetism.**—A term proposed for the quotient of the magnetic moment of a magnet by its mass.
- Specific Molecular Conductivity.**—Molecular conductivity as referred to that of some standard substance.
- Specific Reluctance.**—A term sometimes used for reluctivity.
- Specific Resistance.**—(1) The particular resistance a substance offers to the passage of electricity through it, compared with the resistance of some standard substance. (2) In absolute measurements, the resistance in absolute units between opposed faces of a centimetre cube of a given substance. (3) In the practical system, the above resistance in ohms. (4) Resistivity, expressed in electro-magnetic absolute units as square-centimetres per second.
- Specific Resistance of Liquid.**—(1) The resistance of a given length and area of cross-section of any liquid as compared with the resistance of an equal length and cross-section of pure copper or other standard conductor. (2) Resistivity of a liquid.
- Spectrograph.**—A word proposed for radiograph.
- Spectrophone.**—An instrument employed for the exploration of the ultra-red portion of the spectrum.
- Spectro-Photometer.**—(1) A form of photometer suitable for measuring the relative intensities of lights of different qualities. (2) A photometer which compares luminous intensities in successive portions of spectra, frequency by frequency. (3) A spectroscope so arranged as to readily permit of the comparison as to brightness, wave-length by wave-length, of rays from two different luminous sources.
- Spectro-Photometric.**—Of or pertaining to the spectro-photometer.
- Spectro-Photometry.**—Photometry by means of the spectro-photometer.
- Spectroscope.**—An optical instrument for determining the composition of a body by the character of the light it emits, as determined by its component frequencies.
- Spectroscopic.**—Of or pertaining to the spectrum.
- Spectrum.**—A band of multicolored light or radiant energy of different frequencies, obtained by dispersion in a prism or by a diffraction grating.
- Speed Constant.**—In submarine telegraphy, a constant quantity which divided by the product of the capacity and resistance of a cable gives the working speed of the cable in letters per minute.
- Speed Counter.**—Any apparatus for determining the number of revolutions of a shaft.
- Speed and Direction Indicator.**—A telegraph on board ship for indicating the speed of revolution of the propeller shaft and the direction of its movement.
- Speed Indicator.**—A form of speed counter.
- Speed of Rotation.**—(1) The number of revolutions per second, per minute, hour or unit of time generally. (2) The distance passed over in a given time by the circumference of a rotating wheel or pulley. (3) The angular velocity of rotation in degrees or radians per unit of time.
- Speed Recorder.**—(1) An apparatus for recording the instantaneous values of the speed of any machine. (2) An instrument for both indicating and recording the speed of a trolley car from moment to moment.
- Speeding.**—(1) Varying the number of revolutions per second. (2) Increasing a speed of rotation.
- Speeding of Dynamo.**—Varying the speed of a dynamo, for the purpose of obtaining the proper speed required to operate an electro-receptive device placed in its circuit.
- Spelter.**—A name sometimes given to commercial zinc.
- Spent Acid.**—A battery or other acid that has, through use, become too weak for efficient action.
- Spent Liquor.**—Any liquor such as that used in an acid or other bath, that has through use become too weak for efficient action.
- Spewing of Cable Core.**—The mechanical derangement of a cable, whereby the sheathing opens and the core appears on the surface.

Spherical Aberration.—A defect whereby a lens or mirror with spherical faces fails to produce in its images the correct outlines of objects, owing to the fact that the curvature of one or both of its faces should slightly depart from the true spherical form in order to produce a true image.

Spherical Armature.—An armature for a dynamo, the coils of which are wound on a spherical iron core.

Spherical Bougie Decimale.—(1) A unit of luminous flux equal to that which would be produced by a point source having an intensity of one bougie decimale in all directions. (2) A luminous flux equal to 12,566 lumens.

Spherical Candle-Power.—(1) The total flux of light emitted by a luminous source divided by 12,566. (2) The candle-power of a point-source, which emits with uniform intensity in all directions, as much light as does an actual lamp. (3) The average candle-power of a luminous source taken in all directions, or considered over the entire surface of an enveloping sphere.

Spherical Candle-Power Measurer.—An instrument for measuring, or enabling to be measured, the mean spherical candle-power of a source of light from a single observation.

Spherical Candle-Power Photometer.
(1) A photometer designed to measure the mean spherical candle-power of a lamp. (2) A photometer designed to measure the mean spherical candle-power of a luminous source from a single observation.

Spherical Harmonics.—Homogeneous functions of rectilinear space-co-ordinates which satisfy Laplace's equation.

Spherical Strain Insulator.—An insulator for a guy-wire or trolley pull-off, spherical in form.

Spherometer.—An apparatus for readily measuring the curvature of a sphere.

Sphygmogram.—A record made by a sphygmograph.

Sphygmograph.—An instrument for recording the movements of the pulse, usually of the radial artery at the wrist.

Sphygmograph, Electric.—An instrument for electrically recording the peculiarities of the pulse.

Sphygmophone.—An apparatus employing a microphone for the medical examination of the pulse.

Sphygmoscope.—An apparatus for detecting, but not recording, the peculiarities of the pulse.

Spider.—A radial bracket or support for supporting an armature or machine on a revolving shaft.

Spider Arm.—One of the projections of a spider support.

Spin.—(1) The curl of a vector point-function. (2) Rotation. (3) Vorticity.

Spiral.—(1) A helix. (2) A word sometimes employed in electricity and magnetism for an open conducting coil.

Spiral Accumulator.—An accumulator whose plates consist of two parallel plates of lead insulated from each other and rolled into a close spiral.

Spiral Loop System of Parallel Distribution.—A modified form of loop system for parallel distribution.

Spiral Loop System of Distribution.—A name given to a variety of parallel distribution adopted for obtaining a comparatively uniform distribution of potential, in which the parallel conductors are extended in the arcs of spirals from the generating station throughout the district to be served, both spirals extending from one pole of the generator nearly to the other pole.

Spiral Winding.—A solenoidal winding.

Spiralled Fours of Cable.—A defect in the winding of a telephone cable, in which any four wires are so wound about the core that one pair is not on the average midway between the other pair, so that cross-talk is sure to result.

Splice Bar.—A fish plate employed for connecting together the ends of a rail.

Splice Box.—A box provided for holding splice joints and loops so arranged as to be readily accessible for examination, rearrangement, cross-connection, etc.

Splicing.—Connecting the sheathings of the two ends of a cable at a joint.

Splicing Ear.—(1) A trolley ear for uniting the ends of a trolley wire. (2) A splicing suspension ear.

Splicing Mallet.—A mallet used in a submarine cable splice for laying on a serving of yarn under tension.

Splicing Sleeve.—A tube of conducting material employed for covering a splice in a conducting wire.

Splicing Suspension Ear.—A metal piece suitably supported on an insulator and provided in a system of overhead trolley wires for connecting two separate ends of the trolley line.

Splicing Tool.—A tool employed in making a cable splice, for forcing the sheave wires around the cable in their

- proper spiral position corresponding to that which they have on other parts of the cable.
- Splicing Tube.**—A name sometimes given to a connector employed in making a joint in a trolley wire.
- Split Battery.**—A voltaic battery connected in series and having one of its middle-plates connected to the ground.
- Split Condenser.**—(1) A condenser so arranged that its different sections can be readily inter-connected in the same circuit or employed in different circuits as may be required. (2) A subdivided condenser.
- Split Current.**—(1) A divided current. (2) A current tapped from a main telegraph wire.
- Split Dynamometer.**—A dynamometer employed in connection with alternating currents provided with two coils, so arranged that separate currents of the same frequency can be passed independently through each.
- Split Lead-Tee.**—A T-shaped lead tube that is split for readily covering a joint at a branch in a cable.
- Split Phase.**—A difference produced between the phases of two or more alternating currents into which a uniphase alternating current has divided.
- Split-Phase Motor.**—(1) A multiphase motor operated from a uniphase alternating-current circuit by the introduction of a phase-splitting device. (2) A multiphase motor in which the multiphase currents are locally produced from a single-phase circuit.
- Split-Pin Plug.**—A plug having two halves or two sleeves insulated from each other, employed for readily introducing a loop into a circuit.
- Split-Ring Magnet.**—A ring-core magnet provided with an air-gap.
- Split-Secondary of Induction Coil.**—The secondary of an induction coil which is divided into two equal portions.
- Spluttering of Arc.**—A spluttering sound attending the formation of a voltaic arc.
- Spokes of Armature Core.**—Radial projections on a spider in an armature core, on which coils are sometimes wound.
- Sponge Electrode.**—A therapeutic electrode provided with a sponge.
- Spontaneous Electricity.**—A term formerly employed for the electricity produced by the melting of sulphur.
- Spot.**—The reflected image or luminous patch of light on a mirror galvanometer scale.
- Spotty Filament.**—The filament of an incandescent lamp possessing such local variations in resistance that when rendered luminous by the passage of the current, it possesses points of unequal brilliancy.
- Spreader Bracket.**—A name sometimes given to a loop bracket.
- Spreader for Arc Wires.**—A form of loop bracket employed on arc circuits.
- Spreading of Magnetic Field.**—A term sometimes employed for divergence of a magnetic field.
- Sprengel Mercury Pump.**—A mercurial air pump in which the vacuum is obtained by means of the fall of a stream of mercury through a tube in such a manner as to entangle portions or bubbles of residual air.
- Spring Ammeter.**—A form of ammeter in which a magnetic core or needle is moved against the action of a spring by the field of the current it is measuring.
- Spring Clips of Switch.**—Spring jaws of a switch which grasp the blade or blades in the closed position.
- Spring Contact.**—(1) A contact which either opens or closes under the action of a spring. (2) A spring-supported contact, connected with one part of a circuit, that completes the circuit on being moved so as to touch another contact connected with the other part of the circuit. (3) A circuit-closing or circuit-opening device normally maintained in one position and condition by the action of a spring.
- Spring Dynamometer.**—A dynamometer whose operation is dependent on the action of a spring.
- Spring Jack.**—A form of spring contact provided with a hole for the insertion of a plug.
- Spring-Jack Cut-Out.**—A cut-out operated by a spring jack.
- Spring-Jack Telephone Switchboard.**—A form of telephone switchboard provided with calling drops, clearing out drops, and spring jacks, so arranged as to readily enable a number of subscribers to be placed in inter-communication.
- Spring Manometer.**—A manometer whose operation is dependent on the deformation of an elastic solid.
- Spring Relay-Contact.**—A form of relay contact which is interrupted by the action of a spring as soon as the circuit is broken.

- Spring-Snag Lever-Switch.**—A form of switch operated by a spring snap lever.
- Spring-Suspended Street-Railway Motor.**—A street-railway car motor suspended from the car truck by means of springs.
- Spring Voltmeter.**—A form of voltmeter in which the potential difference is measured by the movement of a magnetic needle, coil, or core, against the pull of a spring.
- Spurious Hall Effect.**—An apparent transverse electromotive force in conductors carrying electric currents in magnetic fields, by changes, produced by magnetism, in the conductivity of the metals and the consequent production of local disturbances in the electrical flow, thus resulting in an apparent transverse electromotive force.
- Spurious Resistance.**—A false or apparent resistance arising, from the development of a counter-electromotive force.
- Square Conductor.**—A form of power conductor with rectilinear cross-section.
- Square Mil.**—(1) A unit of area employed in measuring the areas of cross-section of wires, equal to .000001 square inch. (2) A unit of area equal to 1.2732 circular mils.
- "Squeeze."**—In electro-typing the impression obtained by subjecting a type, or woodcut, to a plate or mass or soft wax.
- Squeezer.**—A device for testing the ductility of a wire, consisting in a receptacle, somewhat resembling a lemon squeezer, in which the wire is placed and clamped and the device opened and closed until the wire breaks.
- Squirted Filament.**—A filament for an incandescent lamp made by the carbonization of a carbonaceous paste, that is shaped by being squirted by pressure through a suitably shaped die hole.
- Stabile Galvanization.**—A term employed in electro-therapeutics in which the current is caused to pass continuously and steadily through the portions of the body undergoing galvanization.
- Stable Equilibrium.**—(1) The equilibrium of a body supported on a base, such that in order to overturn it, its centre of gravity must be raised. (2) The equilibrium of a body so supported that any small displacement raises its centre of gravity.
- Stable Period of Circuit.**—(1) That condition of a circuit in which the current passing through it has reached its full strength, and is no longer undergoing variations. (2) The permanent state.
- Stage Regulator.**—A controller of incandescent lamps in a theatre, placed near the stage, whereby they may be lighted, extinguished, or dimmed.
- Staggered Armature.**—An armature in which the conductors do not lie on its surface in a direction parallel to the axis of rotation, but cross its surface diagonally.
- Staggering of Dynamo Brushes.**—A term sometimes applied to the position of the brushes on a commutator cylinder, in which one brush is placed slightly in advance of the other, so as to wear the commutator surface smoothly, and prevent the formation of grooves.
- Stalk of Insulator.**—The support or inner metal cylinder of an aerial line insulator.
- Standard.**—A metallic pole supported on the roof of a house for carrying overhead wires.
- Standard Candle.**—(1) A candle of definite composition, which, when burned at the rate of two grains per minute, will produce a light of a definite and fixed brightness. (2) A legal standard of light in Great Britain.
- Standard Cell.**—A standard voltaic cell.
- Standard Clock.**—A clock employed for the comparison of other clocks.
- Standard Coil.**—A standard resistance coil.
- Standard Compass.**—A compass on board ship which is used as a standard and by which other compasses may be checked or compared.
- Standard Cross-Arms.**—Wooden cross-arms of standard dimensions for supporting aerial wires on poles.
- Standard Earth - Quadrant.**—(1) A length approximately equal to 10,000 kilometres. (2) One quarter of the meridian circle of the earth taken through Paris. (3) A standard unit of inductance.
- Standard Feeder.**—A term sometimes applied to a principal feeder, operated at standard pressure.
- Standard Luminous Intensity.**—(1) Any unit of luminous intensity employed as a standard. (2) A luminous intensity of one *violle*, *bougie-decimale*, *Hefner-Alteneck*, *carcel*, British standard candle, etc.
- Standard Megohm.**—A resistance equal to one million ohms, employed as a standard.
- Standard Ohm.**—A length of wire having

- a resistance of the value of one ohm, employed in standardizing resistance coils.
- Standard Quadrant.**—(1) The standard earth quadrant. (2) A standard inductance equal to one quadrant.
- Standard Resistance.**—A known resistance used for comparison with, or determination of, an unknown resistance.
- Standard Resistance Coil.**—A coil whose resistance is that of a standard ohm or some multiple or sub-multiple thereof.
- Standard Telephone Switchboard.**—A name applied to a form of multiple switchboard commonly employed in the United States.
- Standard Time.**—Mean solar time used in telegraphy, and referred either to the meridian of Greenwich, or to some other meridian west of Greenwich, an exact number of hours.
- Standard Voltaic Cell.**—A voltaic cell whose electromotive force is practically constant, and which can, therefore, be used as a standard in the measurement of an unknown electromotive force.
- Standard Wire Gauge.**—A wire gauge adopted by the National Telephone Exchange Association and the National Electric Light Association of America.
- Standards.**—(1) Telegraphic or telephonic supports placed on the roof of a building for the purpose of supporting the wires or conductors. (2) A general term for a resistance coil, voltaic cell or other standard employed for purposes of comparison. (3) A term applied to the support of the bearings of a dynamo or motor.
- Standardized Resistance Coil.**—A coil whose resistance has been carefully obtained by comparison with a standard.
- Standardizing a Voltaic Cell.**—Determining the exact value of the electromotive force of a voltaic cell, in order to permit it to be used as a standard in obtaining the electromotive force of any electric source.
- Standing Torque.**—Starting torque.
- Star Current in Polyphase System.**—(1) A current between any line or terminal of a polyphase system and the neutral point. (2) The current in any branch of a star polyphase system.
- Star Grouping of Polyphase Circuits.** A method of grouping a triphase circuit consisting of making a common junction at one point and branching them star-wise.
- Star Potential in Polyphase System.**—The effective difference of potential or voltmeter pressure between any line or terminal of a polyphase system and the neutral point.
- Star Triphase-Winding.**—A connection of three triphase windings in which all three are connected together at a common point or junction point, and the three free ends connected to the terminals.
- Star Triphaser.**—A triphaser possessing a star triphase winding.
- Starting Box.**—A name sometimes applied to a starting resistance.
- Starting Box for Electric Motor.**—A resistance provided for starting an electric motor.
- Starting Box of Shunt-Wound Motor.** A box provided with a rheostat of variable resistance, introduced into the armature circuit of a shunt-wound motor for the purpose of preventing the rush of current made on first connecting the motor with the driving-circuit.
- Starting Coil of Motor.**—A coil employed as a starting resistance for an electric motor.
- Starting Current of Motor.**—The current traversing the coils of a motor at its moment of starting.
- Starting Motor for Synchronous Motor.**—A small electric motor sometimes employed for bringing the armature of a synchronous single-phase motor up to its proper speed before connecting it with the driving-current circuit.
- Starting Position of Street-Car Controller.**—(1) The position of a street-car controller switch at which the current is cut off from the motors. (2) The position of a street-car controller switch, at which the current is first admitted to the motors when starting.
- Starting Resistance.**—A resistance employed in the starting box for an electric motor.
- Starting Rheostat.**—Coils of wire mounted in a suitable manner, and so connected as to be successively placed in the circuit of a motor while it is being started.
- Starting Torque of Motor.**—(1) The torque required in starting a motor. (2) The torque developed by a motor in starting.
- Static Balance.**—A duplex or quadruplex balance adjusted for the capacity of a line by the use of a condenser.
- Static Balance of Duplex System.**—(1) The capacity balance of a duplex system as distinguished from the resistance balance. (2) A balance for charging and

discharging as distinguished from a balance for steady currents.

Static Breeze.—An electric breeze obtained by a convective discharge or an electrostatic discharge.

Static Compensating Condenser.—A condenser employed in the artificial line of duplex or quadruplex telegraphy.

Static Compensator.—A condenser employed for compensating the electro-static capacity of a line in the duplex system.

Static Discharge.—A name sometimes given to a disruptive discharge.

Static Electricity.—A term applied to electricity produced by friction.

Static Electro-Motor.—An electro-motor operated by the repulsion of electric charges.

Static Energy.—(1) A term used to express the energy possessed by a body at rest, resulting from its position as regards other bodies, in contradistinction to kinetic energy, or the energy possessed by a body whose atoms, molecules and masses are in actual motion. (2) Potential energy.

Static Hysteresis.—(1) A term sometimes applied to that quality in iron or other paramagnetic substance, by virtue of which energy is dissipated during every reversal in its magnetization, in contradistinction to viscous hysteresis. (2) Electrostatic dielectric hysteresis.

Static Induction.—A term sometimes employed for electrostatic induction.

Static Insulation.—A term employed in electro-therapeutics for a method of treatment by convection streams or discharges, in which the patient is seated on an insulated stool connected to one pole or electrode of an influence machine, while the other pole or electrode is connected to the ground.

Static Magnetic Induction.—The induction which takes place in the field of a magnet whose flux is stationary as regards the body in which the induction is occurring.

Static Shock.—(1) A term employed in electro-therapeutics for a mode of applying Franklinic currents or discharges by placing the patient on an insulating stool and applying one pole of a static machine provided with small condensers or Leyden jars, while the other pole is connected to the body of the patient. (2) An electro-static shock.

Static System of Induction Telegraphy.—A system of induction telegraphy depending on static induction be-

tween the sending and the receiving instrument.

Static Time Constant.—The electrostatic time constant of a circuit.

Static Transformer.—A term sometimes employed for an ordinary transformer, to distinguish it from a rotary transformer.

Static Voltmeter.—(1) A voltmeter operating by electrostatic action, as opposed to a voltmeter operating electro-magnetically. (2) A voltmeter in which the moving system is displaced by electrostatic forces. (3) A voltmeter of the electro-scope or electrometer type.

Statics.—(1) That branch of science which treats of the relations that must exist between the points of application of forces and their direction and intensity, in order that equilibrium may result. (2) The science of forces at rest.

Station Circuit - Breaker.—A circuit-breaker in a central station.

Station Indicator.—(1) A name sometimes given to a station voltmeter. (2) Any indicator situated at a central station.

Station Load.—The total load existing on a central station at any time.

Station Load-Curve.—A curve representing the station load at different times.

Station Panel.—(1) A panel in a central-station switchboard. (2) A load panel in a central-station switchboard showing the total load of the station. (3) A panel in a central-station switchboard connecting a feeder running to some other station or sub-station.

Station Recording-Wattmeter.—A wattmeter suitable for use in a central station for recording the energy delivered by the station.

Station Switch.—(1) A switch in a station. (2) A switch for connecting an auxiliary station to a system. (3) A switch supplying an auxiliary station. (4) A switch for connecting the lighting or other local wires in a central station to the system of distribution.

Station Transformer.—(1) A transformer placed in a central station. (2) A transformer which supplies a load in a station. (3) A transformer intended to supply current to lamps and potential indicators on the switchboard in the station.

Stationary Transformers.—A word sometimes applied to ordinary alternating-current transformers, in contradistinction to rotary transformers.

- Stationary Electric Motor.**—An electric motor that is fixed to the floor or ground, in contradistinction to a travelling or locomotor.
- Stationary Fare-Register for Street Car.**—A register placed permanently in a car, for the purpose of recording the fare received by a conductor.
- Stationary Floor-Key.**—A name sometimes applied to a floor push.
- Stationary Hook of Telephone.**—A fixed hook provided for holding a telephone.
- Stationary Motor.**—A motor that is fixed in place, in contradistinction to a locomotor.
- Stationary Secondary of Induction Motor.**—An induction motor whose secondary coils form the stator.
- Stationary Tachometer.**—Any tachometer employed for indicating the number of revolutions per minute of a shaft in a stationary rotating machine.
- Stationary Torpedo.**—A term sometimes employed for a submarine mine.
- Stator.**—That part of a dynamo or motor, whether the armature or the field, which remains at rest or stands still during the operation of the machine, as distinguished from the rotor or part which rotates.
- Stator Armature.**—(1) An armature of a dynamo or motor that remains at rest during the operation of the machine. (2) An immovable element of a machine which is also its armature.
- Stator Circuit.**—The circuit of the stator coils.
- Stator Coils.**—The coils placed on the stator of a dynamo or motor.
- Stator Currents.**—Currents that flow in the stator of a dynamo or motor.
- Stator Field.**—A field of a dynamo or motor that remains at rest during operation.
- Statute Mile.**—A length employed in Great Britain equal, by statute, to 5280 feet.
- Stauroscope.**—A form of polariscope for investigating the effects of polarized light on crystals.
- Stay-Eye Clip.**—An iron band rigidly clamped to roof beams or other strong supports and carrying an iron ring for the attachment of a stay-rod.
- Stay Rod.**—A rod of iron or steel, used to stay or support a telegraph or telephone pole.
- Stay Tightner.**—A swivel for taking up slack in a stay.
- Steady Current.**—A current whose strength does not vary from time to time.
- Steam Dynamo.**—(1) A name applied to a steam-turbine dynamo. (2) A dynamo direct-connected to a steam engine.
- Steam Governor, Electric.**—A device used in connection with a valve to so electrically regulate the supply of steam to an engine that the engine shall be driven at such a speed as will maintain either a constant current, or constant potential.
- Steam-Turbine Dynamo.**—A high-speed dynamo whose armature is driven by means of a steam turbine.
- Steaming Lights, Electric.**—A term sometimes applied to the side lights of a ship.
- Stearn's Relay Shunt.**—A shunt employed in the differential method of duplex telegraphy to short-circuit the relay and then permit the line current to be cut off directly after it has completed its work in closing the local circuit.
- Steel Facing of Electro-Type.**—A thin electrolytic deposit of iron placed on the surface of an electro-type for the purpose of hardening it.
- Steel-Yard Ammeter.**—A form of ammeter in which the strength of a current is measured by means of the electro-magnetic forces applied to one extremity of a steel-yard lever, provided with sliding weights for balancing these forces.
- Steeps.**—A word sometimes employed in electro-plating for dips or dipping liquids or solutions.
- Steering Compass.**—A compass employed for the steering of a ship.
- Steering, Electric.**—Steering effected electrically.
- Steering Telegraph.**—A telegraph on board ship for communicating steering orders from some point such as the bridge or conning tower.
- Steno-Telegraphy.**—A system of telegraphy in which the sounds of a word are represented by characters instead of by letters.
- Step-by-Step Annunciator.**—An annunciator operated on the step-by-step principle.
- Step-by-Step Telegraphy.**—(1) A system of telegraphy in which the signals are registered by the movements of a needle over a dial on which the letters of the alphabet are marked. (2) Dial telegraphy.

Step-Down Converter.—A step-down transformer.

Step-Down Transformer.—(1) A transformer in which a small current of comparatively great difference of potential is converted into a large current of comparatively small difference of potential. (2) An inverted Ruhmkorff induction coil.

Step-Up Converter.—A step-up transformer.

Step-Up Transformer.—A transformer in which a large current of comparatively small difference of potential is converted into a small current of comparatively great difference of potential.

Steradian.—(1) A unit of solid angle. (2) The solid angle subtended at the centre of a sphere of unit radius by a unit of spherical area, or unit of surface on the sphere.

Stereopticon.—A lantern apparatus for projecting on a screen a stereoscopic picture.

Stereoscope.—An optical apparatus for obtaining from two photographic pictures, taken in slightly different positions, pictures correctly representing solid objects.

Stereoscopic.—Of or pertaining to a stereoscope.

Stereotype.—A fac-simile or duplication of a page of movable types or of engravings, effected by obtaining a moulding of the original in some suitable material, and then immersing the mould in melted type metal.

Sterilization, Electric.—Sterilizing a solution by depriving it, by means of electric currents, of whatever germs it may contain.

Stern Sheave.—(1) A large sheave on the stern of a cable-ship for paying out cable. (2) Any sheave at the stern of a boat or vessel used in paying out cable.

Stethoscope.—An instrument for ascertaining the condition of the organs of circulation and respiration by the sounds they produce.

Sticking.—(1) A name given by telegraphers to the failure of a relay armature to leave the magnet pole and break contact on the cessation of the current. (2) Undue adhesion between the contacts of a relay.

Sticking of Magnetic Armature.—The adherence of the armature of any electro-magnet to its poles after the current has ceased to pass through the magnetizing coils.

“Stiff Field.”—A magnetic field of comparatively high density.

Stilography.—A modified form of glyphography.

Stimulus of Nerve, Electric.—The effect which electricity produces by its passage through a nerve.

Stock Ticker.—A step-by-step printing telegraphic instrument, employed in transmitting stock quotations to brokers' offices from stock exchanges.

Stock-Ticker Service.—A term employed for the transmission of stock quotations from stock exchanges to subscribers.

Stoneware Dipping-Bowl.—A perforated bowl made of stoneware, in which articles are placed that are to be subjected to the dipping process in electro-metal-lurgy.

Stoneware Dipping-Basket.—A stoneware dipping bowl.

Stopped-Off.—Subjected to the stopping-off process.

Stopper Incandescent Lamp.—An incandescent lamp in which the mounted filament, instead of being hermetically sealed in the lamp chamber, is placed therein by means of a tightly fitting stopper.

Stopper Lamp.—A stopper incandescent lamp.

Stopping-Off.—A process employed in electro-plating, in which a metallic article, already electro-plated over its entire surface, is electro-plated with another metal over certain parts only.

Stopping-Off Process.—A process employed in electro-plating by means of which an article which is to be electro-plated on portions of its surface only with one metal, and on other portions with another metal, is first completely covered by an electro-plating of the cheaper metal, and then stopped-off by covering, with a coating of non-conducting varnish, such portions only of its surface as are not to receive the deposit of the more precious metal.

Stopping-Off Varnish.—A varnish used in electro-plating to cover portions which are not to receive the metallic coating.

Stopping-Out Process.—A process employed in electro-typing, by means of which those parts of an electro-type mould that are not to be copied in the electro-type are covered with clean hot wax.

Storage Accumulator.—A term sometimes used for storage battery.

- Storage Battery.**—A number of separate storage cells connected so as to form a single electric source.
- Storage-Battery Car.**—An electric car which carries the storage battery employed for its propulsion.
- Storage-Battery Meter.**—A meter connected with a storage battery for the purpose of indicating the electric quantity, or energy, left in the same.
- Storage-Battery Traction.**—Electric car traction obtained by means of storage batteries.
- Storage Capacity.**—The capacity of a storage battery, as measured in ampere-hours.
- Storage Cell.**—(1) Two relatively inert plates of metals or metallic compounds immersed in an electrolyte incapable of acting on them until after an electric current has been passed through the liquid from one plate to the other, and has thus changed their chemical relations. (2) One of the cells required to form a secondary battery. (3) A term sometimes given to the jar containing a single cell.
- Storage-Cell Tester.**—A convenient form of electrode provided for ready attachment to the individual cells of a storage battery, for the purpose of ascertaining their electromotive forces from time to time.
- Storage of Electricity.**—A term improperly employed to indicate such a storage of energy as will enable it to directly reproduce electric energy.
- Storage of Energy.**—The change from any form of kinetic energy to any form of potential energy.
- Storm, Electric.**—(1) Any unusual condition of the atmosphere as regards the quantity or distribution of its free electricity. (2) A thunder storm.
- Stove-Plate, Electric.**—An electrically heated stove-plate.
- Stragglng Flux.**—Leakage flux.
- Straight Connector.**—A connector for coupling two wires in the same straight line.
- Straight-Filament Incandescent Lamp.**—An incandescent lamp provided with a straight filament.
- Straight-Line Insulator.**—An insulator employed for a trolley line, where the conductor is supported by transverse wires from poles placed on either side of the roadway.
- Straight-Line Suspension.**—Suspension by means of a straight-line trolley hanger.
- Straight-Line Trolley Hanger.**—A trolley hanger employed on a straight trolley line, suitably supported by a span wire so as to have a vertical strain only.
- Straightaway Bunched Cable.**—A bunched cable, the separate conductors of which are placed in successive layers, and extend in the direction of the length of the cable without any twisting, as distinguished from a helically wound cable.
- Strain.**—The deformation produced by the action of a stress.
- Stranded Conductor.**—A conductor formed of a number of smaller interlaced or twisted conductors, either for the purpose of reducing self-induction, or eddy currents, or for increasing its flexibility.
- Stranded Core.**—A core whose conductor is stranded, as opposed to a core whose conductor is a solid wire.
- Stranded Feeder Conductor.**—A feeder conductor formed of stranded wires.
- Stranded Line.**—A line formed of a stranded conductor.
- Stranding of Conductor.**—Forming a conductor of a number of separate conductors or strands.
- Strap Coppers.**—Copper conductors formed of bars or straps, employed in connection with a bar-armature winding.
- Strap-Driven.**—A term sometimes employed for belt-driven.
- Strap Key.**—A key made from an elastic strip or strap of metal.
- Strap Switch.**—A switch made from a strip or strap of metal.
- Straps and Climbers.**—A device employed by line-men for climbing wooden telegraph poles.
- Stratham's Electric Fuse.**—A form of fuse in which the ignition is effected by an electric spark.
- Stratification Tube.**—A vacuum tube whose residual atmosphere displays alternate dark and light striæ, or stratifications, on the passage through it of an induction-coil discharge.
- Stratified.**—Arranged in separate layers or strata.
- Stratified Discharge.**—The alternate light and dark spaces assumed by the discharge of an induction coil through a partially exhausted gas.
- Stray Chain.**—In submarine cable-work, a length of chain which attaches the end of a buoyed cable to the mushroom anchor mooring chain.
- Stray Currents.**—A term sometimes used for eddy currents.

Stray Field.—(1) Leakage magnetic flux.

(2) That portion of a magnetic field which does not pass through an armature or other magneto-receptive device.

Stray Flux.—The flux of a stray field.

Stray Power.—That portion of the power applied to drive a machine which is lost by various frictions.

Stream-Lines of Escaping Fluid.—Lines which show the actual paths of the particles of an escaping fluid.

Streamers.—Pillars or parallel flashing columns of light frequently seen during the prevalence of an aurora.

Streaming Discharge.—A form assumed by a flaming discharge between the secondary terminals of an induction coil, when the frequencies of the alternations increase beyond a certain limit, and the potential is consequently increased.

Streamings.—(1) A term sometimes employed for electrostatic or electro-magnetic flux. (2) X-ray streamings.

Street Call-Point in Fire Telegraphy. Any point in a street where an alarm call-box is placed.

Street-Car Controller.—(1) An electric switching apparatus contained in a box placed on the platform of an electric street-car, and employed to control the speed of the car. (2) A car-controller.

Street-Car Lamp.—An incandescent lamp provided with an anchored filament, suitable for use in a street-car.

Street-Car Motor.—A motor employed for the propulsion of a trolley car.

Street-Car Recording Watt-Meter.—A wattmeter designed for use on a street-car for registering the amount of electric energy delivered to a car in a given time.

Street Load-Diagram.—A diagram showing the electric load on each street of any particular district of electric supply.

Street Mains.—In any system of electric distribution, the conductors extending through the streets from junction box to junction box, through which the current is distributed from the feeders, and from which service wires are taken.

Street Railway, Electric.—(1) Any electrically propelled street railway. (2) The ordinary trolley system of electric car propulsion.

Street Service.—(1) In a system of incandescent-lamp distribution that portion of the circuit which is included between a main and the service cut-out. (2) That portion of service conductors which lies outside of the building served. (3) In a

system of electric distribution including street lighting, service wires supplying street lamps.

Strength of Current.—(1) A general term for the magnitude of the current in a circuit. (2) Amperage.

Strength of Magnetic Field.—The magnetic force acting on a free unit magnetic pole placed in any magnetic field.

Strength of Magnetism.—A term sometimes used for intensity of magnetization.

Stress.—The pressure, pull or other force, producing a deformation or strain.

Stress Flux.—(1) A general term for the flux producing any stress. (2) The surface integral of stress passing through a surface.

Stretching Insulator.—An insulator of extra mechanical strength provided with means for carrying a short extra length of wire, twisted around a stem such that the excess can be employed for making a joint, or for other purposes.

Striæ, Electric.—Parallel streaked bands, consisting of alternate light and dark spaces, produced in low-vacuum tubes by an electric discharge through them.

Striking.—Subjecting an article to the action of a striking bath.

Striking an Arc.—Separating the carbon electrodes for the formation of an arc between them.

Striking Bath.—A bath containing less silver and a greater proportion of free cyanide, employed in silver plating, for obtaining an almost instantaneous deposit of silver before subjecting the object to the regular plating bath.

Striking Distance.—A term sometimes employed for sparking distance, or the distance through which a disruptive discharge will pass.

Striking Mechanism of Arc Lamp.—The mechanism employed in an arc-lamp to separate the carbons on the establishment of the arc.

Stringing Wires.—Placing aerial wires on poles or other supports.

Strip Commutator.—A commutator formed of plates or flat strips as opposed to a commutator whose segments are strips placed edgewise.

Strip Fuse.—A name sometimes applied to a safety strip.

Strip Resistance.—A resistance formed of strip or strap conductors.

Stripping.—Dissolving the metal coating from a silver, gold or other plated article.

Stripping Bath.—A bath employed for removing an electro-plating of gold, silver or other metal, either by simple dipping or by electric action.

Stripping Liquid.—(1) The liquid employed in a stripping bath. (2) The liquid employed to remove the coating of one metal from the surface of another without affecting the other metal.

Stroboscope.—An instrument employed in the study of periodic motion.

Stroboscopic.—Of or pertaining to the stroboscope.

Stroboscopic Disc.—A disc employed in a stroboscope.

Strong-Current Arrester.—Any form of arrester suitable for protecting a line from a strong current produced by accidental contact with a trolley, power or lamp circuit.

Struck.—A word employed in electro-plating to characterize a surface that has been covered with a film of electrolytically deposited silver or nickel, by being placed in a bath and exposed for a few moments to the action of a strong current.

Structural Carbon.—A term applied to a carbon lamp-filament obtained by the carbonization of any structural carbonizable material such as bamboo.

Structural Magnetic Flux.—(1) Magnetic flux produced by the alignment of the individual molecular magnets in iron, steel or other magnetic substance. (2) Magnetic flux produced by means of a structural magneto-motive force. (3) Magnetic flux produced by iron or other magnetic metal as opposed to flux produced by electric currents.

Structural Magneto-Motive Force.—(1) A name sometimes given to an aligned or induced magneto-motive force, in order to distinguish it from the prime magneto-motive force. (2) A magneto-motive force produced by aligning or structurally arranging the molecular magneto-motive forces inherent in iron, steel, or other magnetic substance.

Structureless Carbons.—A term sometimes applied to carbon filaments that are obtained by the carbonization of a structureless material, such as tamadine or celluloid.

Struts for Telegraph Poles.—Inclined wooden or iron props applied to telegraph poles in order to resist thrusts or pressures.

Sturgeon's Wheel.—A name sometimes applied to Barlow's wheel.

Sub-Aqueous.—Under water.

Sub-Aqueous Cable.—(1) A cable em-

ployed for use under water, generally under fresh water, as in crossing a river. (2) A river cable as distinguished from a sea cable.

Sub-Branch.—A term sometimes employed for a branch taken out of or tapped from a branch.

Sub-Centre Transformer.—A transformer placed at, and supplying secondary circuits radiating from, a sub-centre of distribution.

Sub-Divided Conductor.—(1) A stranded conductor. (2) A compositely formed conductor. (3) A multiple-wire conductor.

Sub-Divided Transformer.—(1) A transformer having subdivisions in its primary or secondary coils. (2) A transformer having a sub-divided magnetic circuit.

Sub-Exchange for Telephones.—A local exchange in connection with a central exchange.

Sub-Mains.—(1) Conductors which branch off from the mains. (2) Mains which are themselves branches of mains.

Sub-Marine.—Under the sea.

Sub-Marine Boat, Electric.—A boat capable of being propelled and steered while under water.

Sub-Marine Board.—(1) A complete set of sub-marine cable telegraphic instruments mounted on a board. (2) A sub-marine cable testing board.

Sub-Marine Cable.—A cable designed for use under water, generally under the ocean.

Sub-Marine Finder.—A form of induction balance proposed for the location of torpedoes, anchors, iron ships or other metallic submerged articles.

Sub-Marine Fuse.—A fuse employed for the ignition of a sub-marine mine.

Sub-Marine Key.—A key suitable for use in sub-marine telegraphy.

Sub-Marine Mine.—A mass of gun-cotton or other explosive material contained in a water-tight vessel and placed under water so as to explode on the passage of an enemy's vessel over it.

Sub-Marine Search Light.—An incandescent light employed for sub-marine exploration.

Sub-Marine Sentry.—A device sometimes employed in sub-marine cable work for indicating the presence of very shallow water, and consisting of a water kite which is below the vessel and which rises to the surface when it strikes the sea-bottom.

Sub-Marine Telegraph.—A general term for the apparatus employed in sub-marine telegraphy.

Sub-Marine Telegraphy.—(1) A system of telegraphy in which the line wire consists of a sub-marine cable. (2) A system of telegraphy across oceans.

Sub-Marine Telephony.—Telephony carried on by means of sub-marine cables.

Sub-Permanent Magnetism.—A term sometimes employed for the character of the magnetism in an iron ship, as distinguished from that of a magnetized steel bar, and as indicating that the permanence in the magnetism of the former is not as marked as in that of the latter.

Subscriber's Indicator.—In a telephone switchboard, the indicator or drop connected in a subscriber's circuit and operated by his call.

Subsidiary Distributing Board.—A distributing board auxiliary to a multiple telephone switchboard, and from which the subscribers' lines are portioned to the local spring jacks for the various operators, in order to equally distribute their work.

Sub-Station.—An auxiliary station.

Sub-Station Accumulator.—An accumulator employed at sub-stations, or auxiliary centres of distribution.

Sub-Station Transformer.—A transformer employed at an auxiliary station or sub-station.

Substitute Primary Coil.—(1) A secondary-primary coil. (2) An intermediate coil in a transformer which alternately takes the part of a secondary and primary.

Substitution Method.—A method of measuring resistances, currents, electromotive forces, etc., by removing them from a circuit and replacing them by a known or adjustable corresponding resistance, current or electromotive force.

Subterranean.—Under the earth.

Subterranean Mine.—An underground mass of gunpowder, or gun-cotton or other high explosive, placed in suitable vessels for protection against moisture, provided with an electrically connected fuse, which is either exploded automatically on the movement of an enemy over it, or by a distant operator.

Sub-Transformer Station.—In a system of electric distribution by alternating currents, an auxiliary station at which transformers are placed for local secondary distribution.

Sub-Trunk Telephone Line.—(1) An

auxiliary trunk telephone line. (2) A trunk line connecting telephone exchanges and used for making connections with trunk lines.

Suburban Communication.—Telephonic or telegraphic communication between the suburbs and central portions of a city.

Suburban Electric Railway.—An electric railway connecting the centre of a city with the suburbs.

Subway, Electric.—An accessible underground way or passage provided for the reception of electric-light wires or cables.

Successive-Contact Key.—Any form of key employed to make two or more successive contacts.

Sugg.—A name sometimes given to a standard British candle.

Sulphating.—A name applied to one of the sources of loss in the operation of a storage cell, by means of the formation of an inert coating of lead sulphate on the surface of the battery plates.

Summer Lightning.—A name sometimes given to heat lightning.

Sunflower Commutator.—(1) A commutator resembling a sunflower in appearance. (2) A form of flat or disc commutator.

Sun-Light Color-Values.—Such luminous frequencies in a source of artificial light as will give to its light the same effects as are produced by sunlight.

Sunshine.—The luminous radiant energy emitted by the sun.

Sun-Spot Disturbance.—Any disturbance due to, attributed to, or accompanying, the presence of spots on the sun.

Sun-Spots.—Dark spaces, varying in number and position, which appear on the surface of the sun.

Sun-Stroke, Electric.—(1) Electric prostration produced by exposure to the light of an electric arc. (2) Physiological effects similar to those produced by exposure to the sun, experienced by those exposed for a long time to the intense light and heat of the voltaic arc.

Sun Telegraph.—A name sometimes applied to the heliograph.

Sunk Winding.—(1) A name sometimes employed for an iron-clad winding. (2) A winding sunk below the surface of an armature or other device.

Superficial Eddy-Currents.—Eddy currents produced in conducting substances that are limited to the outer layers thereof.

- Superficial Field.**—A field produced by the super-position of two or more separate fields.
- Superposed Magnetism.**—A term applied to a magnetism impressed on an already magnetized substance.
- Super-Saturation.**—A condition of a solution which has been allowed to cool, while out of contact with air, below its point of crystallization or solidification.
- Super-Saturation of Solution.**—The condition assumed by a warmed saturated solution of a salt when placed in a closed vessel out of contact with the air, and allowed to cool, without being shaken.
- Supervising Operators.**—In telephony, or telegraphy, operators whose duty it is to supervise the work of other operators.
- Supplement of Angle.**—What an angle needs to bring its value to 180° .
- Supplementary Dynamo.**—A word sometimes used for a booster dynamo.
- Supply Conductors.**—(1) A term sometimes applied to the sub-mains in a system of incandescent light distribution. (2) Conductors which convey electric energy.
- Supply Mains.**—A term sometimes applied to the mains in a system of incandescent light or power distribution.
- Supply Meter, Electric.**—A meter which indicates or measures the electricity or electric energy supplied to a given customer or machine.
- Supply Unit.**—A name proposed for the Board of Trade unit.
- Support Plate of Storage Cell.**—A term sometimes employed for the grid of a storage cell.
- Surface Action.**—Any action limited to a surface.
- Surface Contact of Street-Railway Car.**—A contact, flush with the surface of a street, and intended for use in connection with the electric propulsion of a street-railway car.
- Surface Contact-Resistance between Metal and Liquid.**—The resistance introduced into a primary or secondary cell at the contact between the metal and liquid.
- Surface Contact Street Railway System.**—A system of street-railway propulsion employing surface contacts.
- Surface Density.**—The quantity of electricity-per-unit-of-area at any point on a charged surface.
- Surface-Efficiency of Filament.**—(1) The efficacy of a particular character of surface for luminous radiation. (2) The luminous efficiency of a particular character of surface in a filament.
- Surface Integral.**—(1) The sum of all the products of a point function and its associated element of area, lying on a surface, when the elements are all indefinitely small. (2) The integral of a quantity taken over a surface.
- Surface Integral of Magnetic Induction.**—The total magnetic flux passing through a surface.
- Surface Magnetization.**—In the distribution of imaginary magnetic matter, the magnetism residing on a surface, or the so-called free magnetism.
- Surface-Wound Armature.**—(1) An armature wound on its surface, as distinguished from an iron-clad armature. (2) An armature in which the conductors lie over the surface of the core, instead of being placed in grooves or slots formed therein.
- Surfusion.**—A word sometimes employed for super-saturation.
- Surgical Lamp.**—A lamp employed in surgical exploration, examination, or operation.
- Surging Circuit.**—Any circuit through which a surging discharge is passing.
- Surging Discharge.**—(1) A discharge accompanied by electric surgings. (2) An oscillatory discharge.
- Surgings, Electric.**—(1) Electric oscillations set up in a conductor that is undergoing rapid discharging, or in neighboring conductors that are being rapidly charged and discharged. (2) Electric oscillations, direct or induced.
- Susceptance.**—In an alternating-current circuit, branch, or conductor, the quantity whose square added to the square of the conductance is equal to the square of the admittance.
- Susceptibility.**—A word sometimes used for magnetic susceptibility.
- Suspended Cable-Way.**—A modification of the trolley system, in which a carriage provided with one or more grooved wheels is electrically driven over a suspended cable.
- Suspended-Coil Galvanometer.**—Any form of galvanometer in which the current passing is measured by the movements of a suspended coil.
- Suspended Trolley-Way.**—(1) A suspended cable-way. (2) A form of trolley system.
- Suspender.**—A word sometimes used for a cable suspender.

- Suspender for Telephone Cable.**—(1) A word sometimes employed for cable hanger. (2) A hook or support for a telephone cable.
- Suspending Hook for Telephone Cable.**—A cable hanger.
- Suspending Wire of Aerial Cable.**—(1) The wire from which an aerial cable is strung or suspended. (2) A messenger wire.
- Suspension.**—(1) The mechanism for suspending a thing, with or without the thing suspended. (2) The means employed in suspending any system, such as a needle, a pendulum, or a car motor.
- Suspension for Car-Motor.**—The means employed for supporting a car-motor on a car truck.
- Sustained Currents, Electromotive Forces or Fluxes.**—Any electromotive force, current or flux, whose effect is continued, as distinguished from one whose effect is temporary.
- Swage.**—A particular form of anvil on which highly heated metallic plates are shaped by hammering them into forms the same as that of the anvil on which they are placed.
- Swage.**—To fashion heated metallic plates by hammering them into the form of the anvil on which they are supported.
- Swaging.**—Fashioning highly heated metallic plates into any desired form by hammering, while on suitable dies.
- Swaging, Electric.**—Forming or shaping of metallic plates by hammering them against suitable anvils or dies while softened by electric heat.
- Sweating.**—A term employed for the process of soldering together the ends of electric-light cables.
- Swelling Current.**—In electro-therapeutics, a current that begins weak and is then periodically made stronger and weaker.
- Swelling Faradic-Currents.**—A term employed in electro-therapeutics for Faradic currents that are caused to gradually increase in strength and then to gradually decrease to zero strength.
- Sweep.**—(1) In submarine cable work, a drag. (2) In submarine cable work, a haul made with a grapnel across a line of cable.
- Sweeper, Electric.**—A term employed for an electrically-driven sweeper.
- Sweeping-Out Charge.**—A phrase employed in double-current signalling for freeing the line from a charge produced in sending one signal, by reversing the direction of the current through the line before sending the next signal.
- Swinging Annunciator.**—A pendulum annunciator.
- Swinging Cross.**—A term sometimes given to an intermittent cross.
- Swinging Earth.**—A name sometimes given to an intermittent earth.
- Swinging Voltmeter.**—A voltmeter mounted upon a swinging bracket of a switchboard, so as to be capable of being read from any direction.
- Swiss Commutator Switchboard.**—A switchboard having cross-bars after the type of a Swiss commutator.
- Switch.**—(1) Any device for readily opening or closing an electric circuit. (2) In telephony, a name sometimes given to a switchboard.
- Switch-Bell.**—(1) A bell switch. (2) A combination of a bell and switch.
- Switch Blade.**—A conducting strip or knife-blade of a switch.
- Switch-Board.**—(1) A board, base, slab or frame of insulating material, upon which are supported conducting bars, pieces, frames or masses, with or without switches and instruments, for the ready establishment of electrical connections between circuits connected therewith. (2) A board carrying switches and instruments for controlling a distribution system and the generators connected therewith. (3) A board provided with a switch or switches by means of which electric circuits connected therewith may be opened, closed or interchanged. (4) In a central station for telegraphy, telephony, light or power distribution, the electric controlling mechanism.
- Switch Cord.**—An insulated conducting cord connected with a switch.
- Switch-Board Arrester.**—A device intended for use on switchboards, consisting either of some form of lightning arrester or of a sneak-current arrester.
- Switch-Board Bolt.**—A bolt for mechanically fastening apparatus to a switchboard or the panels of a switchboard to a frame.
- Switch-Board Bracket.**—A bracket on a switchboard for supporting an incandescent lamp or other device.
- Switch-Board Cable.**—Any cable connected with a switchboard.
- Switchboard Fittings.**—A general term embracing the connectors, set screws, wire-holders or bus-bar connections, em-

- ployed in placing the different apparatus on a switchboard.
- Switch-Board Protector.**—(1) A protector provided with a suitable electro-magnetic safety device, or with a fuse wire or safety catch, placed at cable heads, at the junction between aerial-land and underground lines, for the purpose of protecting the cable from a too powerful electric discharge or current. (2) Any lightning, or circuit protector, placed on a switchboard.
- Switchboard Transformers.**—Transformers on an alternating-current switchboard for locally supplying alternating-currents of reduced pressure.
- Switch-Board Wattmeter.**—A wattmeter placed on a switchboard to determine the out-put, or the intake, of some circuit connected therewith.
- Switch-Box.**—Any box containing one or more switches.
- Switch-Finger.**—A contact-finger, or projecting metallic contact on the cylinder of a street-car controlling-switch, or on similar apparatus.
- Switch-Handle, Electric.**—In electric railway block-signalling, a miniature railway electric switch handle for closing and opening an electric circuit.
- Switch Hole.**—A hole provided in a switch key for the insertion of a plug.
- Switch Hook.**—(1) An automatic telephone hook. (2) A hook which serves the purpose of a switch.
- Switch Jack.**—A spring jack.
- Switch Pin.**—A metallic pin or plug provided for insertion in a switchboard.
- Switch Room.**—The room or hall in a central telephone exchange in which a switchboard is placed.
- Switch Spring.**—A spring placed in a switch for its mechanical operation, or for securing electric connection.
- Switched-In.**—Thrown into a circuit by means of a switch.
- Switched-Out.**—Removed from a circuit by means of a switch.
- Swivel Clevis.**—A device consisting essentially of a nut and bolt, by means of which any slack in a guy-rod may be taken up.
- Symmetrical Alternating Current.**—Any alternating current whose successive semi-periods, waves, or alternations possess opposite but equal values, or correspond in all respects save in direction.
- Symmetrical Alternating Electromotive Forces.**—Electromotive forces whose successive semi-waves or alternations possess equal but opposite values, or correspond in all respects save in direction.
- Symmetrical Induction of Armature.**—(1) An induction produced by the simultaneous passage of the same quantity of magnetic flux through adjoining halves of the armature. (2) A symmetrical magnetization in an armature.
- Symmetrical Magnetic Field.**—A field whose magnetic flux is symmetrically distributed.
- Symmetrical Polyphase System.**—A polyphase system symmetrically arranged in regard to conductors, pressures, currents and loads.
- Sympathetic Electric Vibrations.**—(1) Electric vibrations produced in a circuit by the electro-magnetic waves given off by a neighboring circuit. (2) Electric vibrations that are produced by resonance.
- Sympathetic Generator.**—An induction generator.
- Sympathetic Vibrations.**—Vibrations set up in bodies; and having the same frequency as that produced by the exciting body.
- Symphonance.**—A word proposed in place of resonance.
- Synchronism.**—(1) Unison of frequencies in alternating-current systems or apparatus. (2) The simultaneous occurrence of any two events. (3) Generally, the co-periodicity and co-phase of two periodically recurring events. (4) The coincidence in cyclic recurrence of two or more periodic variables, without regard to amplitude.
- Synchronizable.**—Capable of being synchronized.
- Synchronize.**—(1) To cause to occur or act simultaneously. (2) To bring two alternating-current machines into unison or co-periodicity, and into practical coincidence of phase, so that they may be connected together.
- Synchronized.**—Caused to occur or act simultaneously.
- Synchronizer.**—(1) Anything causing or tending to cause synchronism. (2) A phase indicator. (3) A device for indicating when synchronism is attained between alternators that are to be connected in parallel.
- Synchronizing Dynamo-Electric Machines.**—Adjusting the frequencies and phases of two alternating-current dyna-

- mos so as to permit of their being coupled or joined in parallel.
- Synchronizing Torque.**—The torque of an alternating-current generator or motor armature tending to bring it into synchronism with some other armature operated with it.
- Synchrograph.**—A name given to a record obtained by a polarizing photoelectric apparatus.
- Synchronous.**—(1) Occurring simultaneously in point of time. (2) Generally, co-periodic and co-phasal, as distinguished from isochronous, which connotes agreement in period only.
- Synchronous Generator.**—A generator of alternating currents, operating or capable of operating in synchronism with another generator.
- Synchronous Motor.**—A form of alternating-current motor which requires to be brought into step with the driving current before it will properly operate.
- Synchronous Multiphase Motor.**—A multiphase motor designed to operate in isochronism with the generator or generators connected with it.
- Synchronous Multiplex Telegraph.**—A general term for the apparatus employed in synchronous multiplex telegraphy.
- Synchronous Multiplex Telegraphy.**—A system of simultaneous telegraphic transmission in which a number of messages, either all in the same direction, or part in one and the remainder in the opposite direction, can be simultaneously transmitted over a single line wire.
- Synchronous Reactance.**—(1) The apparent reactance of a synchronous motor armature under working conditions (2) The combined apparent reactance of self-induction and armature reactance of a synchronous motor armature under working conditions.
- Synchronous Speed.**—The speed of a motor or generator at which it is in synchronism with the current in the system to which it is connected.
- Synchronous Vibrations.**—Vibrations produced by two or more separate systems that exactly coincide, both in frequency and in phase.
- Synthesis.**—(1) Indirect analysis or the formation of a chemical substance by the combination of its constituent parts. (2) The building-up or combination of atoms into molecules.
- System of Electric Lighting.**—(1) A term sometimes applied to an electric light installation. (2) An electric light plant.

T

- t.**—A symbol employed for time.
- t : m.**—An abbreviation for turns-per-minute, a practical unit of angular velocity.
- T. P. Switch.**—A contraction for triple-pole switch.
- T-Connector.**—A connector provided for connecting a wire with two branch wires, and resembling the letter T in shape.
- T-Shaped Spark.**—A variety of three-branched spark obtained by the discharge of a Leyden jar through a peculiar form of induction coil.
- Table-Key.**—A key placed on the table of a telephone exchange for effecting the connections with an operator.
- Table Push.**—A push-button connected with a table for ease in ringing a call-bell.
- Table Switch.**—A switch on the table of a telephone switchboard.
- Tablet Board.**—A switchboard divided into panels or tablets.
- Tablet Check.**—In telegraphy, a tabulated form upon which messages sent and received are checked off for the purpose of recording the traffic and ensuring against the loss of a message.
- Tachograph.**—An apparatus for recording the number of revolutions per minute of a machine or shaft.
- Tachometer.**—(1) An apparatus for indicating at any moment on a dial the number of revolutions per minute of a shaft or machine with which it is connected. (2) A speed indicator.
- Tachyphore.**—(1) A name proposed for a system of electric transportation in which a carriage formed of magnetic material is propelled by the sucking action of solenoids placed along the tracks, and energized in succession during the passage of the car. (2) A port-electric system.
- Tail Light.**—A light displayed at the rear of a train, in order to avoid rear-end collisions.
- Tail of Mercury.**—An elongation or tail, of grayish color, due to the presence of

- oxides, left behind a drop of impure mercury, when moved over smooth surface.
- Tailings.**—(1) In telegraphy, residual discharges from the line through the receiving instrument, following each signal, and thus tending to make the signals run together. (2) Residual or return charges or currents in the transmission of electromagnetic waves through a dielectric.
- Talantoscope.**—A low-vacuum tube employed in connection with a Hertzian oscillator to determine when it is sending forth waves, and when it is under the influence of unidirectional discharges and is not sending forth waves.
- Talking Circuit.**—In telephony, a circuit employed by a subscriber during conversation, as distinguished from a calling circuit.
- Tamadine.**—A modified form of tri-nitro cellulose, employed, when cut into suitable shapes and subsequently carbonized, for the filaments of incandescent lamps.
- Tangent.**—(1) One of the trigonometrical functions. (2) In a right-angled triangle formed by a radius-vector, base, and perpendicular, the ratio of the perpendicular to the base.
- Tangent and Sine Galvanometer.**—A galvanometer furnished with two magnetic needles of different lengths, the small one being used for tangent measurements, and the long one for sine measurements of current strength.
- Tangent Galvanometer.**—An instrument in which the deflecting coil consists of a coil of wire within which is placed a needle, supported at the centre of the coil, and very short by comparison with the diameter of the coil.
- Tangent Scale.**—A scale designed for use with a tangent galvanometer on which the values of the tangents are directly marked, instead of degrees of the circle as ordinarily, thus avoiding the necessity of finding from tables, tangents corresponding to the degrees.
- Tangentially - Laminated Armature Core.**—An armature core consisting of a closely-coiled ribbon of sheet iron.
- Tank-Heater, Electric.**—A form of electric heater for heating liquids, consisting essentially of a heating coil immersed in a liquid contained in a tank.
- Tanning, Electric.**—The application of electric currents to the tanning of leather.
- Tap.**—(1) A conductor attached as a shunt to a larger conductor. (2) A derived circuit for carrying off a share of the main current. (3) A wire taken from the junction between the short and long sections of a quadruplex battery.
- Tap Wire in Quadruplex Telegraphy.** The intermediate wire or conductor in a system of quadruplex telegraphy, which divides the battery into two unequal parts, called respectively the long side and the short side.
- Tap Wires.**—The wires or conductors employed in trolley systems to carry the current from the feeders or mains at a pole to a near point on the trolley wire.
- Taped Conductor.**—A taped wire.
- Taped Wire.**—(1) A conducting wire covered with an insulating material in the shape of a tape. (2) A wire covered with an insulating material and subsequently taped.
- Tapered Mains.**—Mains in the tree system whose diameters diminish in successive sections.
- Taping.**—(1) Covering a wire or a joint with an insulating tape. (2) A covering of tape applied to a cable sheathing.
- Tapers.**—Wires tapering in diameter for the purpose of effecting a splice between two different types of submarine cables.
- Tapper Bell.**—A single-stroke electric bell provided with a suitable key for signalling purposes.
- Tapper Key.**—A term sometimes employed in place of a Morse tapper.
- Tapper Signal.**—In a system of mining signals, signals sent or received by means of tapper bells.
- Tapping a Circuit.**—Introducing a loop or branch in a telegraphic or telephonic circuit, for the purpose of intercepting the messages sent over the circuit.
- Taps.**—A general term employed, in a system of incandescent lamp distribution, for branches or sub-branches that are carried from the mains into the rooms of a building or to the fixtures in the halls.
- Target, Electric.**—A target in which the point struck by the ball is automatically registered by means of electric devices.
- Tasimeter.**—An apparatus designed by Edison for the purpose of detecting minute heat changes by variations in the resistance of a soft-carbon disc, resulting from changes of pressure due to the expansion of a substance exposed to the heat to be measured.
- Teaser.**—An electric current teaser.
- Teaser, Electric.**—(1) A coil of fine wire placed on the field magnets of a dynamo in a shunt across the main circuit, in addition to the field magnet series

- coil. (2) A series coil placed on a field magnet, in addition to a regular shunt field, for the purpose of preliminary excitation.
- Teaser Winding.**—An additional coil wound on the armature of a monocyclic generator of smaller cross-section and fewer turns than the main winding, one end of which is connected at the centre of the main winding, and the other to a collecting ring.
- Tee Box for Underground Cables or Conductors.**—A box, shaped like a letter T, and containing a joint or joints between a main line and an offset, branch, lateral, or service conductor.
- Tee Connector.**—A T-shaped connector employed for readily connecting a wire at right angles to another wire.
- Teeth of Armature.**—Polar projections or ridges on the surface of an armature-core, between which lie the armature windings or conductors.
- Tele-Anemograph.**—A device for recording the indications of an anemograph at a distance.
- Tel-Autogram.**—A recorded message obtained by means of a tel-autograph.
- Tel-Autograph.**—A telegraphic system for the fac-simile reproduction of writing at a distance.
- Tele-Autograph.**—An orthography sometimes employed for tel-autograph.
- Tele-Barograph.**—A device for recording the indications of a barometer at a distance.
- Tele-Barometer, Electric.**—An electric recording barometer, for indicating and recording barometric pressures at a distance.
- Telegram.**—Any despatch received by means of a telegraph.
- Telegraph.**—(1) A general name for the instrument or combination of instruments employed for conveying a communication or despatch to a distance by means other than that of the unassisted voice. (2) A general term for any apparatus employed in telegraphy.
- Telegraph.**—To transmit a message by means of a telegraph.
- Telegraph Circuit.**—(1) An electric circuit employed in telegraphy. (2) An insulated line apparatus at one or more telegraph stations and a ground return circuit.
- Telegraph, Electric.**—A general term for any apparatus employed in electric telegraphy.
- Telegraph Line-Adjuster.**—A general term given to apparatus by means of which the adjustment of a telegraph line is facilitated.
- Telegraph Loop.**—A pair of wires extending from a telegraphic station to a branch office.
- Telegraph Posts.**—A term sometimes employed for telegraph poles.
- Telegrapher.**—A telegraphic operator.
- Telegrapher's Cramp.**—An affection of the hand of a telegrapher, due to continuous excessive use of the same muscles, somewhat similar to the disease known as writer's cramp.
- Telegraphic.**—Of or pertaining to a telegraph.
- Telegraphic Alarm.**—An alarm bell for calling the attention of an operator to a telegraphic instrument when the latter is of the non-acoustic or needle type.
- Telegraphic Alphabet.**—The code employed for letters and other characters in telegraphy.
- Telegraphic Arm.**—A cross-arm placed on a telegraphic pole for the support of the insulators.
- Telegraphic Box-Sounder.**—A sounder whose receiving magnets are enclosed in a hollow box, for the purpose of increasing the intensity of the sound by resonance.
- Telegraphic Bracket.**—A support or cross-piece placed on a telegraph pole, tree, wall or roof, for the support of a telegraphic line-insulator.
- Telegraphic Cable.**—A cable designed to establish telegraphic communication between different points.
- Telegraphic Clock.**—A name sometimes applied to a master clock.
- Telegraphic Code.**—The pre-arranged system of signals employed in any system of telegraphy.
- Telegraphic Cross-Arm.**—A term sometimes employed for telegraphic arm.
- Telegraphic Dial.**—A dial board containing letters of the alphabet and figures, employed in dial telegraphy.
- Telegraphic Dynamo.**—A dynamo employed for generating the currents used in telegraphic transmission.
- Telegraphic Earth-Circuit.**—That portion of a telegraphic circuit which is completed through the earth or ground.
- Telegraphic Embosser.**—An apparatus for recording a telegraphic message on a paper strip in raised or embossed characters.

- Telegraphic Fixtures.**—A term generally limited to the various supports provided for the attachment of telegraphic wires.
- Telegraphic Ground-Circuit.**—An earth circuit used in any system of telegraphy.
- Telegraphic House-Top Fixtures.**—Telegraphic fixtures placed on the roofs of buildings for the support of the lines.
- Telegraphic Ink-Writer.**—(1) A device employed for recording the dots and dashes of a telegraphic message in ink on a strip of paper. (2) A Morse inker.
- Telegraphic Insulator.**—An insulator employed on telegraphic lines.
- Telegraphic Interrupter.**—(1) A device for making and breaking a circuit at a definite rate. (2) A telegraphic key, or other analogous device.
- Telegraphic Interruption.**—(1) Any fault in a line or apparatus which prevents telegraphic transmission. (2) A term sometimes employed in telegraphy for faults in general. (3) A break or total stoppage of signals in a submarine cable.
- Telegraphic Joint.**—A permanent contact or junction between the ends of two electric conductors.
- Telegraphic Key.**—The key employed for sending over the line the successive makes-and-breaks corresponding to the dots and dashes of the Morse alphabet, or to the deflections of the needle in a needle telegraph.
- Telegraphic Line.**—A conducting circuit employed in any telegraphic system for the transmission of electric impulses or currents.
- Telegraphic Line-Circuit.**—The conductor or line connecting different telegraphic stations.
- Telegraphic Needle.**—A needle employed in telegraphy to represent by its movements to the right or left, respectively, the dots and dashes of the Morse alphabet.
- Telegraphic Paper-Winder.**—An apparatus for winding or coiling the paper fillet used on a telegraphic register.
- Telegraphic Photography.**—A term sometimes used for means whereby an image of a photographic object may be telegraphically transmitted to a distant station.
- Telegraphic Pocket-Relay.**—A form of telegraphic relay of such small dimensions as to permit it to be readily carried in the pocket.
- Telegraphic Polar-Relay.**—A telegraphic relay provided with a polarized armature.
- Telegraphic Pole.**—A wooden or iron pole provided with suitable insulators for the support of an overhead telegraphic line or lines.
- Telegraphic Register.**—(1) An apparatus employed at the receiving end of a telegraphic line for the purpose of obtaining a permanent record of the telegraphic despatch. (2) A Morse register.
- Telegraphic Registering Apparatus.** (1) A name sometimes given to a telegraphic recorder. (2) A Morse register.
- Telegraphic Repeater.**—(1) Any telegraphic device whereby the relay, sounder or registering apparatus is caused to repeat into another circuit the signals received. (2) An apparatus for maintaining telegraphic communication between two circuits not in conductive connection.
- Telegraphic Saddle.**—A bracket of special shape, placed astride, on the top of a telegraph pole, for the support of an insulator.
- Telegraphic Splice.**—A sheath connection made between two cable ends, and overlying a joint.
- Telegraphic Stay-Rods.**—Guy rods supporting telegraph poles.
- Telegraphic Stock-Printer.**—A form of printing telegraph employed for printing on a strip of paper the quotations of stocks, received from a stock exchange.
- Telegraphic Switchboard.**—(1) A device employed at a telegraphic station, by means of which any one of a number of telegraphic instruments in use at that station may be placed in or removed from any line connected with the station, or by means of which one wire may be connected to another. (2) A switchboard for conveniently effecting and changing telegraphic connections.
- Telegraphic Through-Traffic.**—A general term for the telegraphic messages sent directly between the terminal stations, as distinguished from way traffic, which includes some intermediate station.
- Telegraphic Time-Service.**—(1) Any telegraphic distribution of time. (2) The telegraphic distribution of time to jewelers, railroad time-keepers, or others in need of frequent information as to the precise time, in which electric signals are sent out from a standard clock, through relays, at two second intervals, with special signals at minute, five-minute, and hour intervals.

- Telegraphic Transmitter.**—A tablet having suitable contact marks placed on its surface, such that by moving a metallic rod over it proper signals are sent.
- Telegraphic Translator.**—A term sometimes applied to a telegraphic repeater.
- Telegraphic Way-Traffic.**—Telegraphic messages sent from one office to another, as distinguished from messages between terminal offices only.
- Telegraphic Wire.**—The wires employed in telegraphic line circuits.
- Telegraphical.**—Of or pertaining to the telegraph.
- Telegraphically.**—In a telegraphic manner.
- Telegraphing.**—Sending a communication by means of a telegraph.
- Telegraphist.**—A telegraphic operator.
- Telegraphophone.**—An instrument whereby the indentations on the cylinder of a graphophone can be reproduced upon another cylinder, at the same time that the vocal sounds represented by the indentations are being rendered audible.
- Telegraphy.**—Any system by means of which a communication or despatch is transmitted to a distance, by means other than that of the unassisted voice.
- Tele-Hydro-Barometer.**—An instrument for indicating and recording at a distance the height of water or other liquid in a vessel or reservoir.
- Tele-Hydro-Barometer, Electric.**—An apparatus for electrically transmitting to, and recording at a distant station, the height of water or other liquid.
- Tele-Indicator.**—A term sometimes employed for telemeter.
- Tele-Intensity of Projector.**—The apparent luminous intensity of a search light at a distance.
- Tele-Manometer, Electric.**—A gauge for electrically indicating and recording pressures at a distance.
- Tele-Meteorograph.**—A form of meteorograph, registering at a distance by the aid of electricity.
- Telemeter.**—An apparatus for electrically indicating and recording at a distance the pressure on a gauge, the reading of a thermometer, or the indications of a similar instrument.
- Tele-Metric.**—Of or pertaining to a telemeter.
- Telephone.**—An instrument for the electric transmission of articulate speech.
- Telephone Battery.**—Any form of open-circuit battery, suitable for use in connection with a telephone.
- Telephone Booth.**—A telephone cabinet booth.
- Telephone Cabinet-Booth.**—A silence telephone cabinet.
- Telephone Cable.**—(1) A cable, either aerial or subterranean, suitable for the transmission of telephonic despatches. (2) Generally, a cable whose conductors are twisted in pairs, for the purpose of avoiding the disturbance produced by cross-talk.
- Telephone Call-Bell.**—A bell employed in connection with a telephone circuit for calling a correspondent at the other end of the line to his telephone.
- Telephone Call-Wire.**—(1) A wire employed in certain telephone systems, by the subscriber, for the purpose of calling the central office. (2) A special calling wire in a telephone system.
- Telephone Circuit.**—An electric circuit for the transmission of telephonic messages.
- Telephone Cords.**—(1) Flexible conductors provided for use in connection with a telephone. (2) Flexible conducting cords provided with a telephone switchboard for making connections between subscribers.
- Telephone Cross-Talk.**—A disturbance produced in a telephone circuit by induction or leakage from a neighboring circuit.
- Telephone Drop.**—An annunciator drop used on a telephone switchboard.
- Telephone Exchange.**—A central office provided with circuits, switches and other devices, by means of which any one of a number of subscribers, connected either directly or indirectly with the exchange, may be placed in communication with any other subscriber, or with some other exchange.
- Telephone-Exchange Switchboard.**—A switchboard employed in a central telephone exchange for the purpose of readily placing any subscriber in connection with any other subscriber connected with that system.
- Telephone Galvanometer.**—A high-resistance galvanometer consisting of an electro-magnet, provided with a soft-iron disc delicately mounted between its poles, and permanently bridged across a telephone circuit for the purpose of giving a visual call-signal.

Telephone Head-Gear.—Any apparatus placed on the head for readily attaching a telephone receiver to the ear of the operator.

Telephone Indicator.—(1) An indicator employed on a telephone circuit to indicate the number of the correspondent calling. (2) A telephone drop annunciator.

Telephone Indicator-Coil.—A coil employed on a telephone indicator.

Telephone Meter.—(1) An apparatus employed on telephone circuits for registering the number of connections between subscribers and the time or duration of the same. (2) A calculagraph.

Telephone Relay.—An electro-magnetic relay employed to close an indicator circuit or a call-bell circuit in a telephone system.

Telephone Repeating-Coil.—(1) A form of induction coil employed for repeating a telephonic message. (2) An induction coil having two insulated windings, one in each of the two telephone circuits to be connected.

Telephone Set.—A general term for the apparatus employed by a telephone subscriber at his office.

Telephone Side Tone.—The tone obtained in a telephone receiver by talking to or tapping at its own transmitter.

Telephone Subscriber.—A term applied to a person who is connected with a central telephone station.

Telephone Subway.—A subway provided for the reception of telephone cables or wires.

Telephone Switch.—(1) Any switch employed in connection with a telephone. (2) A switch employed to place either a call-bell or a telephone in a telephone circuit.

Telephone Test-Board.—A board provided in a central-telephone exchange for the leading-in and orderly arrangement of the line wires, between the outside line and the switchboard, for identification and testing.

Telephone Time-Check.—A clock in a telephone exchange by means of which a drop shutter is automatically released, at a particular trunk-wire indicator, at the expiration of the allotted time that a subscriber is given the use of the trunk line, and by which the central-station operator's attention is called to the fact of such expiration. (2) A telephone meter.

Telephone Tinnitus.—(1) A professional

neurosis of the auditory mechanism ascribed to the constant use of the telephone. (2) A nervous auditory disorder attributed to constant use of the telephone.

Telephone Transformer.—(1) An apparatus for repeating into one circuit a telephonic message received on another circuit. (2) A telephone repeating coil.

Telephone Translator.—A telephone repeater.

Telephoner.—(1) A term sometimes applied to a person at one end of a simple telephone line, in contradistinction to a telephone subscriber at the end of a circuit connected with any telephone exchange. (2) Any one carrying on a conversation by means of a telephone.

Telephonic.—Of or pertaining to a telephone.

Telephonic Alarm.—(1) An alarm bell for calling a correspondent to his telephone. (2) A call bell.

Telephonic Cable.—A telephone cable.

Telephonic Cross-Connection.—Telephonic transposition.

Telephonic Exchange.—A telephone exchange.

Telephonic Insulator.—Any insulator employed in connection with a telephone line.

Telephonic Line.—The line wire or circuit employed in telephonic transmission.

Telephonic Joint.—A joint effected between the ends of two wires in a telephone circuit.

Telephonic Meter.—A telephone meter.

Telephonic Receiver.—(1) The instrument employed in receiving a telephonic message. (2) The instrument held to the ear for the purpose of receiving a telephonic message.

Telephonically.—By means of a telephone.

Telephonist.—Any one employing a telephone.

Telephony.—The art of transmitting articulate speech by means of a telephone.

Telephote.—(1) An apparatus for the telegraphic transmission of pictures by means of the action of light on selenium. (2) The pherope.

Tele-Photography.—A system of facsimile transmission by dots and dashes transmitted by means of a continuous current, whose intensity is varied by a transmitting instrument containing a selenium resistance.

Tele-Radiophone.—A form of radiophone arranged for the simultaneous transmission of telegraphic and telephonic messages.

Telescope.—An optical instrument for rendering distant objects visible by enlarging their apparent dimensions and by increasing the amount of the light emitted by them that reaches the eye.

Telescopic.—Of or pertaining to the telescope.

Telescriptor.—A name given to a particular form of printing telegraph.

Teleseme.—A self-registering hotel annunciator by means of which a dial operated in a room indicates the character of the service required.

Telestereoscope.—An optical instrument for causing distant objects to appear in relief.

Tele-Thermograph.—(1) A registering tele-thermometer. (2) The record made by a tele-thermometer.

Tele-Thermometer, Electric.—An electrical recording thermometer, for indicating and recording temperature at a distance.

Telluric Magnetic Force.—A term sometimes employed for the earth's magnetic force.

Telluric Mines.—Explosive mines underground, as distinguished from sub-aqueous, or sub-marine explosive mines.

Telpher.—A general name for the apparatus employed in systems of telerage.

Telpher Line.—The electric circuit employed in a telerage system.

Telpher Locomotion.—The transportation of merchandise by means of a telpher system, or telerage.

Telpher Locomotive.—An electric motor by means of which telpher cars are drawn on a telpher line.

Telerage.—A system for the conveyance of carriages suspended from electric conductors, driven by means of electric motors, that take the current required to energize them directly from the conductors on which they are suspended.

Temper.—To obtain the requisite degree of hardness and elasticity of a metal by cooling while heated.

Temperature.—The thermal condition of a body considered with reference to its capability to communicate heat to other bodies.

Temperature Alarm, Electric.—An electric alarm automatically operated by a change of temperature.

Temperature Coefficient.—(1) A coefficient of variation in a quantity, per degree of change in temperature. (2) The coefficient by which a change of temperature must be multiplied in order to arrive at the change in a quantity due to the change of temperature.

Temperature Elevation.—(1) The excess of temperature of a heated body over the temperature of its environment. (2) The excess of temperature acquired by a conductor traversed by a current over the surrounding air.

Temperature Gradient.—(1) A line representing the rate-of-change of temperature in a body through which heat is flowing. (2) A space-rate-of-change in temperature. (3) A rate-of-change in any quantity varying with temperature.

Temperature Regulating-Switch for Electric Car-Heater.—A switch employed in systems of car heating, whereby the separate heaters may be connected in series, or in parallel groups, between the trolley and the track, or by means of which one or more of the heaters may be removed at will.

Tempering.—Obtaining a change in the hardness and elasticity of a metal by suddenly cooling it while heated.

Tempering, Electric.—A process for tempering metals in which heat of electric origin is employed instead of ordinary heat.

Temporary.—Lasting but for a while.

Temporary Charge by Induction.—An electric charge of a temporary character produced on a conductor by induction, as distinguished from a permanent charge so obtained.

Temporary Currents.—Currents that continue but for a brief interval of time.

Temporary Electromotive Forces.—Electromotive forces which continue but for a brief interval of time.

Temporary Intensity of Magnetization.—The intensity of the magnetization temporarily induced in a bar of soft iron, as distinguished from permanent magnetization induced in hard steel.

Temporary Magnetization.—(1) A word employed for the magnetization produced in a mass of soft iron, when brought into a magnetic field. (2) Magnetization which is temporary in character.

Temporary Magneto-Motive Forces.—Magneto-motive forces that continue but for a brief interval of time.

Temporary Socket.—A socket provided

- for an incandescent lamp that is not intended to be permanently installed.
- Tenacity.**—(1) The stress required to produce a rupture in a mass of given cross section of any material. (2) The power of a material to resist rupture.
- Tension.**—(1) An elongating stress. (2) The strain produced in a substance by the action of a stress. (3) The pressure produced by a confined gas against the walls of the containing vessel, due to molecular impact.
- Tension, Electric.**—A term loosely applied to signify indifferently surface density, electromotive force, electromotive intensity, dielectric stress, or difference of potential.
- Tension-Ratchet.**—A name sometimes given to a line-dynamometer.
- Terminal Board.**—A switchboard situated on a dynamo.
- Terminal Branch Cut-Out.**—A cut-out for a branch taken from the end of a main line.
- Terminal Electromotive Force.**—The electromotive force of a dynamo taken at the terminals of the machine.
- Terminal Insulator.**—(1) An insulator at the terminus of a line. (2) A telegraph line insulator provided with two grooves for the reception of two ends which may be kept insulated from each other.
- Terminal Pole.**—(1) The last pole of a line. (2) A pole of greater dimensions and more securely anchored than the rest, erected at the end of a telegraphic, telephonic, trolley, or power line, or where aerial wires join subterranean cables, and intended to safely resist the lateral tension of the line.
- Terminal Pressure.**—The pressure at the terminals of any electric apparatus.
- Terminal Reflection.**—A term applied to the reflection of electro-magnetic waves from the end of an open-circuited conductor.
- Terminal Telegraphic Station.**—The telegraphic station at either terminus of a line.
- Terminal Voltage.**—The terminal electromotive force.
- Terminals.**—A name indifferently applied to the poles or to the electrodes of a voltaic battery.
- Terra-Cotta Conduit.**—An earthenware conduit.
- “Terra Voltaism.”**—The operation of a telegraph system by a single voltaic element, consisting of a pair of dissimilar metals buried in the earth at opposite ends of the line.
- Terrella.**—A sphere of hardened steel, or of lode-stone, magnetized so that the distribution of its magnetism shall resemble that of the earth.
- Terrestrial Electricity.**—A term proposed for atmospheric electricity.
- Terrestrial Magnetic Induction.**—The production of magnetism by the action of the earth's field.
- Terrestrial Magnetism.**—A name applied to the magnetism of the earth.
- Tesla Coil.**—A form of oil-insulated induction coil or transformer.
- Tesla Discharge.**—A variety of high-frequency, high-pressure discharge.
- Tesla Frequencies.**—A term sometimes applied to frequencies which are much higher than those ordinarily employed.
- Tesla Transformer.**—A step-up, oil-insulated transformer, employed by Tesla in obtaining high-frequency discharges.
- Test Board.**—(1) A board employed in a telegraphic, telephonic, or transmission circuits, generally, provided with the measuring instruments required for testing its insulation and other electrical properties. (2) A board in a telephone station to which telephone lines are connected, for the purpose of quickly connecting the testing instruments to such lines.
- Test Cell.**—A voltaic cell employed for the busy or engaged test in a multiple telephone switchboard.
- Test Circuit.**—In a multiple-telephone switchboard the circuit for the busy test.
- Test Clerk.**—A clerk to whom the duties of testing the telephone lines are assigned.
- Test Loop.**—A loop running to a test board.
- Test Plugs.**—(1) Plugs used in testing. (2) Plugs for insertion in testing jacks.
- Test Ring.**—(1) A call made by the central station to each subscriber to ascertain whether the line is in good operating condition. (2) A ring in front of each jack in a multiple telephone switchboard, and supplying a contact for the busy test.
- Test Room.**—A testing room.
- Test Thimble.**—A thimble at a central telephone exchange carrying a contact, and employed for making a busy test at a multiple telephone switchboard.
- Test Wire for Multiple Switchboard.**—A wire running to a multiple switchboard and connecting all the jacks of the same number in the different sections for the

purpose of enabling the operator to ascertain whether the subscriber needed is busy.

Test Wire of Metallic Circuit.—(1) The return-wire of a metallic circuit. (2) In telephony, that wire in a subscriber's metallic-circuit loop which serves for the busy test at the switchboard.

Test Wires.—(1) The wires in a multiple telephone switchboard, by which the busy test is made. (2) Any wires or circuits used in making a test. (3) Wires to be tested or undergoing a test.

Testing.—(1) Submitting to trial for electric capabilities. (2) Determining the value of the current strength, the difference of potential, the resistance, the coulombs, the farads the joules, the watts, etc., in any circuit. (3) Making electrical measurements, generally.

Testing Bank.—A bank of lamps, or other inductionless resistances, employed in testing a circuit.

Testing Board.—A board employed in a telephone switchboard for the purpose of testing the condition of the lines.

Testing Car for Railway Circuits.—An electric trolley-car provided for making electric tests along a line of street railway while the car is in motion.

Testing Jacks.—In a multiple telephone switchboard, or distributing board, special jacks sometimes inserted in any circuit for testing such circuit.

Testing Magneto.—A magneto-electric machine employed to produce the high electromotive force required in testing high-resistance circuits.

Testing of Joints.—(1) Determining the insulation or conductor resistance of a joint in any circuit. (2) Ascertaining the resistance of the insulating material around a joint in a cable.

Testing Point of Spring Jack.—The tip of a spring jack.

Testing Pole.—A term sometimes employed in electro-therapeutics for the indifferent pole or electrode.

Testing Posts.—Hollow posts provided with a door, placed above an underground cable, into which the wires are sometimes led, employed for ease in opening and testing.

Testing Rod.—An insulated conducting rod employed in testing insulators for dipping into the liquid contained in their sheds, when inverted in a testing bath.

Testing Room.—(1) A room on board a cable-ship provided with instruments for

cable testing and signalling. (2) A room fitted with tables and apparatus for making electrical tests. (3) In a telephone exchange, a room usually near the switch room through which all telephone lines pass and arranged for conveniently testing such lines.

Testing Switch.—In a quadruplex telegraphic system, a switch for throwing the line from the sending battery to ground through a suitable resistance, for the purpose of enabling the distant station to obtain a balance.

Testing Transformer.—(1) A transformer employed in any system of distribution for the purpose of testing for grounds, for the condition of the line, for drop of potential, etc. (2) A transformer employed in testing.

Tetanus.—Continuous spasmodic contraction of the muscles.

Tetrad Atom.—An atom whose valency or atomicity is four.

Tetrivalent.—Possessing a valency or atomicity of four.

Tetrode Working.—A term applied to a four-way mode of working the Delany synchronous multiple telegraph.

Thaumatrope.—An optical toy depending on the persistence of the retinal image, in which two different pictures placed upon the opposite sides of a card are caused, by the rapid rotation of the card, to appear as a single picture.

Theatre Dimmer.—(1) A dimmer employed in theatres for varying the intensity of the illumination. (2) A rheostat or choking coil employed in a theatre-lighting circuit.

Theatre Dimming Rheostat.—A rheostat employed in connection with a theatre dimmer.

Theatrophone.—A system of telephonic communication between theatres or opera-houses and subscribers.

Theodolite.—An instrument employed for measuring angles in vertical or horizontal planes.

Theoretical Magnet.—A hypothetical magnet, assumed for the purpose of mathematical discussion as possessing infinite length and thinness, and uniform magnetization.

Therapeutic Adapter.—An adapter employed in electro-therapeutic work.

Therapeutical Electrization.—Subjecting different parts of the human body to the action of electric currents for the cure of a diseased condition.

Therm.—(1) A heat unit equal to the amount of heat required to raise the temperature of a gramme of water, at the temperature of its greatest density, one degree Centigrade. (2) The smaller calorie.

Therm Calorie.—A word sometimes used for the smaller calorie.

Thermæthesiometer.—An instrument employed in electro-therapeutics for testing the temperature sense in nervous diseases.

Thermal.—Of or pertaining to heat.

Thermal Absorption.—The absorption of heat energy during its passage through a body.

Thermal Activity.—(1) The activity possessed by a body, arising from its heat energy. (2) The rate of doing thermal work. (3) The rate of generating heat.

Thermal Balance.—(1) A differential galvanometer employed for determining small differences of temperature. (2) The bolometer.

Thermal Batteries.—(1) Thermo-piles. (2) Thermo-electric batteries. (3) An electric source operated by heat energy.

Thermal Cautery.—A cautery heated by ordinary heat, as distinguished from an electric cautery, or one heated by heat of electric origin.

Thermal Circuit Closer.—A circuit-closer operated by changes of temperature.

Thermal Coil of Resistance Box.—A coil of wire inserted in a resistance box, and possessing a high temperature sufficient, for the purpose of indicating by its resistance the temperature within the box.

Thermal Current.—A heat current, or one due to the flow or transference of heat through a conductor.

Thermal Current-Strength.—The quantity of heat per second transmitted across any area of normal cross-section of a conductor.

Thermal Diffusivity.—A term proposed for thermometric conductivity, or the ratio of the calorimetrical conductivity to the specific heat per unit volume.

Thermal Electromotive Force of Resistance Coils.—A thermo-electric couple inserted in a resistance box, for the purpose of determining the temperature within it.

Thermal Equivalent of Work.—The equivalent, in heat units, of a given quantity of mechanical work.

Thermal Incandescence.—The shining or glowing of a substance, generally a solid, by means of heat other than that of electric origin.

Thermal Resistance.—The resistance offered by a substance to the passage of heat.

Thermal Resistivity.—(1) Specific thermal resistance. (2) The specific thermal resistance of a substance referred to the thermal resistance of a unit cube between any pair of parallel faces.

Thermally Effective Value.—(1) In an alternating-current circuit, the effective values from thermal measurements or considerations. (2) The square-root-of-mean-square values.

Thermic Balance.—A bolometer.

Thermic Interrupter.—A device operated by the expansion of a metallic wire employed for the purpose of preventing more than a certain number of arc-lamps being used in a circuit where the current is paid for by the number of lights, rather than by the current supplied.

Thermo-Barometer.—(1) A device for determining the elevation of a mountain by observing the temperature at which water boils on that elevation. (2) A hypsometer.

Thermo-Battery.—A term sometimes applied for a thermo-electric battery.

Thermo-Call.—A thermo-electric call.

Thermo-Cell.—A thermo-electric cell.

Thermo-Chemical Cell.—An electric cell, in which a difference of potential is produced by the combined action of heat and chemical action.

Thermo-Chemistry.—That branch of chemistry which treats of the measurement of chemical energy in thermal units.

Thermochrosy.—(1) A word expressive of the fact that ordinary radiant heat, like light, consists of an assemblage of waves of different frequencies. (2) Heat coloration.

Thermo-Electric Battery.—A combination, as a single thermo-electric source, of a number of separate thermo-electric cells or couples.

Thermo-Electric Call.—An instrument for electrically sounding an alarm when the temperature rises above or falls below a fixed point.

Thermo-Electric Cell.—A name applied to a thermo-electric couple.

Thermo-Electric Couple.—Any two dissimilar metals which, when connected at their ends only, so as to form a complete

- electric circuit, will produce an electric current when one end is more highly heated than the other.
- Thermo-Electric Current.**—A current produced by a thermo-electromotive force.
- Thermo-Electric Diagram.**—A diagram in which the thermo-electric power between different metals is given for different temperatures.
- Thermo-Electric Effect.**—The production of an electromotive force at a thermo-electric junction by reason of the difference of temperature between that junction and the other junction of the couple.
- Thermo-Electric Electromotive Force of Voltaic Cell.**—The thermo-electromotive force produced by a voltaic couple.
- Thermo-Electric Element.**—A name applied to either of the metals that form a thermo-electric couple.
- Thermo-Electric Force.**—(1) The force produced by a thermo-electric couple. (2) The electromotive force of a thermo-electric circuit.
- Thermo-Electric Generator.**—A thermo-electric pile.
- Thermo-Electric Inversion.**—An inversion of the thermo-electromotive force of a couple at certain temperatures.
- Thermo-Electric Junction.**—A junction of a thermo-electric couple.
- Thermo-Electric Neutral Point.**—A temperature at which two thermo-electric forces are equal. (2) A temperature at which a junction of two metals has no thermal E. M. F.
- Thermo-Electric Pair.**—A thermo-electric couple.
- Thermo-Electric Pile.**—A thermo-electric battery.
- Thermo-Electric Potential-Difference.** Difference of potential produced by a thermo-electric cell or pile.
- Thermo-Electric Power.**—A number which, when multiplied by the difference of temperatures of a thermo-electric couple, will give the difference of potential generated thereby.
- Thermo-Electric Series.**—A list of metals, so arranged as to their thermo-electric powers, that each in the series is electro-positive to any lower in the list.
- Thermo-Electricity.**—(1) The electromotive forces developed by a thermo-electric cell or battery. (2) Electricity produced by differences of temperature at the junction of dissimilar metals.
- Thermo-Electrification.**—Electrification produced by differences of temperature in a thermo-electric couple.
- Thermo-Electrometer.**—A name sometimes, though not happily, given to an electric thermometer.
- Thermo-Electromotive Force.**—An electromotive force or difference of potential produced by differences of temperature at a thermo-electric junction.
- Thermo-Element.**—A name sometimes employed for a thermo-couple.
- Thermo-Galvanometer.**—A galvanometer employed in connection with a thermopile for the purpose of showing difference of temperature by means of the currents developed.
- Thermo-Luminescence.**—Luminescence produced in a substance by heat at a temperature below that of luminosity.
- Thermolysis.**—The decomposition of a molecule by heat.
- Thermo-Magnetic Generator.**—(1) A device for producing electricity by the combined influence of heat and magnetism. (2) A pyro-magnetic generator.
- Thermo-Magnetic Motor.**—A pyromagnetic motor.
- Thermometer, Electric.**—A device for determining the effects of an electric discharge by the movements of a liquid column due to the expansion of a confined mass of air through which the discharge is passed.
- Thermometric Conductivity.**—The ratio of the calorimetric conductivity to the specific heat of unit volume.
- Thermometric Heat.**—A term proposed for heat in gross matter, as distinguished from radiant heat, or wave motion in the ether.
- Thermometric Resistance Coil.**—A coil whose resistance is known at a given temperature, and employed to determine an unknown temperature to which it is exposed, from the change in its resistance.
- Thermometry.**—That branch of science which treats of the determination of temperature.
- Thermo-Multiplier.**—(1) A word sometimes used for thermo-pile. (2) A form of low-resistance galvanometer suitable for use in connection with a thermo-pile.
- Thermo-Pair.**—A thermo-electric couple.
- Thermophone.**—(1) An electric instrument for producing sound by means of electricity. (2) Any instrument by means of which sounds are produced by the absorption of radiant energy.
- Thermo-Pile.**—A thermo-electric battery.

Thermo-Pile Galvanometer.—A form of galvanometer for detecting small differences of temperature, in which the thermo-pile is placed within the instrument.

Thermoscopic Receiver.—A name sometimes given to a microphonic receiver.

Thermostat.—An instrument for automatically maintaining a given temperature by closing an electric circuit through the expansion of a solid or liquid.

Thermostatic Alarm, Electric.—Any electric alarm operated by the action of a thermostat.

Thermostatic.—Of or relating to a thermostat.

Thermostatic Regulation.—Any regulation, such as in the temperature of a room, effected by the action of a thermostat.

Thermostatic Regulator.—A regulator whose action is dependent on a thermostat.

Thermo - Telephone.—(1) A telephone transmitter consisting of a continuous wire, one end of which is connected with a transmitting diaphragm placed in circuit with the receiving telephone battery, and having a current passed through it of sufficient strength to heat the wire. (2) A telephone receiver in which the diaphragm is set in vibration by thermally-produced changes in the length of an attached wire.

Thermo-Tropic Battery.—A name proposed for a form of carbon battery, in which the E. M. F. is produced by the action of heat.

Thermo-Tropic Current.—The currents produced by a thermo-tropic battery.

Thief Alarm.—A term sometimes employed for a burglar alarm.

Third-Rail Electric Railway.—An electric street-car railway in which a third rail, insulated from the track, is employed for one side of the circuit, the outside rails, together with return feeders, being employed for the other side of the circuit.

Thimble Brush.—A suitably shaped brush employed for cleansing such surfaces as the inside of a thimble, and so preparing them for electro-plating.

Thomson.—A name proposed, but not adopted, for a unit of electric conductivity.

Thomson Effect.—(1) The production of an electromotive force in unequally heated homogeneous conducting substances. (2) The increase or decrease in the differences of temperature in an un-

equally heated conductor, produced by the passage of an electric current through the conductor.

Thomson's Bridge.—A modified form of Wheatstone's bridge employed for the measurement of very small resistances.

Three Ammeter Method of Measurement.—A method of measuring activity in an alternating-current circuit by the combined use of three ammeters in a main and branch circuits respectively.

Three-Bearing Generator.—(1) A belt-driven dynamo-electric generator, provided with a third shaft bearing situated between the armature and the pulley. (2) A generator whose rotor shaft has three bearings.

Three-Bearing Motor.—(1) A belt-driving motor provided with a third shaft bearing between the pulley and the armature. (2) A motor whose rotor shaft has three bearings.

Three-Bearing Railway Generator.—A railway-generator having three bearings for its rotor shaft.

Three-Bladed Switch.—(1) A switch provided with three blades. (2) A switch closing three circuits simultaneously.

Three-Branched Spark.—A form of branched spark obtained by the discharge of a Leyden jar through a peculiar form of induction coil.

Three - Circuit Way - Telegraphic Switchboard.—A form of telegraphic switchboard suitable for use at a way station.

Three-Coil Armature Winding of Alternator.—An armature winding providing three coils in a ring armature or three slots in a drum armature for each and every pole in the field frame.

Three-Coil Armature Winding of Multiphase Alternator.—An armature winding providing three coils in a ring armature or three slots in a drum armature, per phase, for each and every pole in the field frame.

Three Corner Telegraphic Repeater. A telegraphic repeater which repeats from one circuit to two circuits.

Three-Current Test to Instrumental Zero.—A localization submarine cable test, in which three separate measurements of resistance are made with different current strengths in succession, the Wheatstone bridge balance being taken to instrument zero.

Three-Filament Incandescent Lamp for Triphase Circuits.—An incandescent lamp intended for use on triphase

- circuits provided with three leading-in wires connected to the free ends of three filaments which are connected in a common joint.
- Three-Part Commutator.**—A commutator made up of three insulated segments.
- Three-Phase Armature.**—An armature possessing a three-phase winding.
- Three-Phase Armature-Winding.**—An armature winding such as will enable it to produce three-phase currents.
- Three-Phase Bar-Winding for Armature.**—A bar winding for an armature, such as will enable it to produce three-phase currents.
- Three-Phase Circuit.**—Any circuit suitable for the transmission of three-phase currents.
- Three-Phase Coil-Winding for Armature.**—A coil winding for an armature, such as will enable it to produce three-phase currents.
- Three - Phase Continuous --Current Commutating Machine.**—A transformer from triphase alternating to continuous currents, employing a revolving armature provided with a commutator. (2) A triphase rotary transformer.
- Three-Phase Currents.**—Three alternating-currents differing in phase from one another by one-third of a cycle.
- Three-Phase Dynamo.**—A three-phase generator.
- Three-Phase Generator.**—Any generator capable of producing three-phase currents.
- Three-Phaser.**—A three-phase generator.
- Three-Phase Meter.**—A meter suitable for operation on a three-phase system, for recording the energy delivered on all three branches.
- Three-Phase Motor.**—Any motor suitable for operation by three-phase currents.
- Three-Phase Rotary-Converter.**—A rotary converter suitable for use in connection with three-phase currents.
- Three - Phase Rotating - Magnetic Field.**—A rotating field produced by the action of a three-phase current.
- Three-Phase System.**—A system for the transmission of electric energy by means of three-phase currents.
- Three-Phase Transformer.**—Three separate transformers employed for the transformation of triphase currents.
- Three-Phase Transmission.**—Transmission by means of three-phase currents.
- Three-Phase Two-Phase Transformer.** An alternating-current transformer for transforming from three-phase currents to two-phase currents.
- Three-Phase Working.**—Three-phase transmission.
- Three-Phaser.**—(1) A three-phase generator. (2) A triphaser.
- Three-Point Switch.**—(1) A switch by means of which a circuit can be completed through three different contact points. (2) A switch designed to make three distinct contacts.
- Three-Point Trolley Switch.**—A trolley switch provided for a bifurcation in a road, or where a road divides into three branches.
- Three-Voltmeter Method of Measurement.**—A method of measuring activity in an alternating-current circuit, employing three voltmeters simultaneously.
- Three-Way Frog.**—A three-way trolley frog.
- Three-Way Plug.**—A multiple telephone switchboard plug making three contacts at sleeve, ring and tip respectively.
- Three-Way Switch.**—A three-point switch.
- Three-Way Trolley-Frog.**—A trolley frog used where a trolley line branches in three directions.
- Three-Way Trolley-Switch.**—(1) A trolley switch designed for use at a point where the line branches in three directions. (2) A trolley switch with three connections.
- Three-Wire Circuit.**—(1) A circuit employed in a three-wire system. (2) A three-wire diphas system. (3) A three-wire triphase system.
- Three-Wire Diphas.**—A form of diphas circuit containing three wires, in which one of the wires is usually provided with a greater area of cross-section and is employed as the common return.
- Three-Wire Distribution Board.**—A distribution board in a three-wire system.
- Three-Wire Mains.**—The mains employed in a three-wire system of distribution.
- Three-Wire Meter.**—A meter suitable for operation on a three-wire system for recording the power delivered on both sides of the system.
- Three-Wire Moulding.**—Moulding employed in a three-wire distribution system.
- Three-Wire Multiple Switchboard.**—A multiple telephone switchboard in which the jacks in a subscriber's line are

- connected in multiple, and in which three wires run to all jacks.
- Three-Wire Switchboard.**—(1) A telephone switchboard with three wires to each jack. (2) A switchboard employed in a three-wire system of electric distribution.
- Three-Wire Switchboard.**—A switchboard suitable for use in connection with a three-wire system of distribution.
- Three-Wire System.**—A system of electric distribution for lamps or other multiple-connected translating devices, in which three conductors are employed in connection with two dynamos connected in series, the central or neutral conductor being connected to the junction of the dynamos, and the two other conductors to the remaining free terminal of each.
- Three-Wire Transmission.**—(1) Transmission by the three-wire system. (2) Transmission by means of the three-wire diphasic or three-wire triphasic systems.
- Three-Wire Telephone Switchboard.** A branched terminal telephone switchboard.
- Throttling.**—Partially or completely cutting off.
- Throttling of Lines of Magnetic Force.** Any decrease in the density of magnetic flux due to a magnetic joint, or to any decrease in the magnetic permeability of any portion of a circuit. (2) Saturation.
- Through.**—(1) In communication with, telegraphically. (2) Directly connected telegraphically, without intermediate stations. (3) Completed or ended.
- Through Circuit.**—A telephonic or telegraphic circuit that has been completed through to a given station, by cutting out interruptions or breaks in a line, by the connection together of sections of different wires.
- Through Line.**—A line extending between two terminal stations, as distinguished from a line containing way stations.
- Through Telephone Tablets.**—Panels placed in a telephone switchboard for connecting subscribers on different switchboards.
- Throw.**—A term sometimes employed for the excursion or throw of a needle.
- Throw of Needle.**—A phrase sometimes employed for the angular deflection of a needle, particularly when the needle makes its first swing.
- Throw-Back-Indicator, Electric.**—An annunciator with a drop that is automatically replaced.
- Throw-Over Reversing Switch.**—A reversing switch which is operated by throwing it over from one side to the other.
- Throw-Over Starting Switch.**—A throw-over switch employed for starting an electric motor.
- Throw-Over Switch.**—(1) A switch for readily and rapidly changing a circuit from one source to another or one system to another. (2) A switch which is thrown over from one set of contacts to another, by movement about an axis.
- Thumb-Cock Electric Burner.**—An electric gas-burner in which the turning of an ordinary thumb-cock turns on the gas and ignites it by a spark produced by a wiping contact, actuated by the motion of the thumb-cock.
- Thunder.**—The loud noise accompanying a disruptive lightning discharge.
- Thunder Rod.**—A term formerly employed for lightning rod.
- Thunder Storm.**—A rain storm accompanied by thunder and lightning.
- Ticker.**—A word sometimes employed for stock ticker, or printing telegraph.
- Ticket Operator.**—In telephony, an operator at a central exchange whose duty it is to record calls on tickets for that purpose.
- Tie Bar.**—A bar extending across the track at suitable intervals between two opposite rails, and employed to prevent the spreading of the rails.
- Tie Feeder.**—A feeder connecting two stations, two feeders, or two feeding points.
- Tie Line.**—(1) In an electric distributing system, a conductor free from translating devices and employed to equalize potential. (2) A conductor connecting two points in a distributing system for the purpose of equalizing their potentials.
- Tie Sleeper.**—A sleeper laid transversely to a track and serving to retain in place the rails which are fastened to it.
- Tie Wire.**—(1) Binding wire of an insulator. (2) Wire which binds an overhead wire to the groove of its insulator.
- Time Annunciator.**—An alarm clock.
- Time-Ball, Electric.**—A ball suspended in a prominent position on a tall pole and caused to fall at the exact hour of noon, or at any other pre-determined time, for the purpose of giving a visual signal of correct time to an entire neighborhood.
- Time Constant.**—(1) In an electric circuit the ratio of the inductance to the con-

- ductor resistance. (2) In an electric circuit containing a condenser the product of the capacity of the condenser, and the resistance of its discharging circuit.
- Time-Constant of Circuit.**—(1) The time in which a current will fall in a circuit when the E. M. F. is suddenly removed, in a ratio whose Naperian logarithm is unity. (2) The ratio of the inductance of a circuit to its resistance.
- Time-Constant of Condenser.**—The time in which the charge of a condenser falls in a ratio whose Naperian logarithm is unity.
- Time-Constant of Electro-Magnet.**—The time required for the current to fall, when the E. M. F. is suddenly withdrawn, to a ratio whose naperian logarithm is unity.
- Time Cut-Out.**—An automatic cut-out arranged so as to permit a translating device to operate for a certain time, after which it is cut out of the circuit.
- Time Detector, Electric.**—An electrically operated watchman's clock. An apparatus for electrically registering the time at which a watchman visits one or more stations and closes or opens a circuit connected with the register.
- Time Fall of Electromotive Force of Secondary Cell.**—A gradual decrease in the potential difference of a secondary or storage cell observed during its discharge.
- Time Flow.**—The ratio expressed in ergs-per-square-centimetre, of the amount of energy which is passed through a normal area of cross-section, to that cross-section.
- Time Gun.**—A gun that is automatically fired by a standard clock, for the purpose of giving a time signal to an entire neighborhood.
- Time Hysteresis.**—A term sometimes incorrectly employed for magnetic creeping.
- Time-Illumination.**—(1) A given illumination that is continued for a given time. (2) The effect produced by an illumination continued for a time. (3) The product of illumination and time.
- Time-Lag of Magnetization.**—(1) A lag which appears to exist between the time of the action of the magnetizing force, and the appearance of the magnetism. (2) In an alternating-current choking-coil or transformer, the lag of magnetization due to hysteresis, expressed as a time or fraction of a period.
- Time Meter, Electric.**—An electric meter whose operation is based on a record of time during which an electric current is passing.
- Time of Oscillation.**—The time of vibration.
- Time of Vibration.**—The time required for a complete to-and-fro motion of the particles of an elastic medium.
- Time Register.**—Any device for registering a lapse of time.
- Time Register for Railroads.**—A telegraphic apparatus or register designed to record a telegraphic message transmitted over a line.
- Time Relay.**—(1) A relay employed in a form of stock ticker for momentarily delaying the releasing of a clutch and the closing of a transmitter, until the printing of a given letter has been assured. (2) A relay employed in a system of time signalling.
- Time-Rise of Electromotive Force of Secondary Cell.**—A gradual increase in the potential difference of a secondary or storage cell observed during charge.
- Time Switch.**—(1) A switch arranged to open or close a circuit at a certain time or after the lapse of a certain time. (2) An automatic switch in which a predetermined time is required either to insert a resistance into or remove it from a circuit.
- Time Telegraph.**—A general term for the apparatus employed in time telegraphy.
- Time Telegraphy.**—A system for the telegraphic transmission of time.
- Tinned Wire.**—Wire electro-plated with tin.
- Tinning Metal.**—The solder employed in joining electrotype shells or for preparing their backs for the reception of the backing metal.
- Toe of Grapnel.**—A prong of a cable grapnel.
- Toll Station.**—A pay telephone or telegraph station.
- Toll System.**—A system of charging for telephone communications based upon telephone calls, as distinguished from a charge based upon rental.
- Tone.**—Any musical note of a definite frequency.
- Tongue of Relay.**—The tip or extremity of the armature, carrying a contact point.
- Tooling.**—The operation of shaping a gutta-percha covered joint by the application of a warm tool to its surface.
- Toothed-Core Armature.**—A laminated armature-core whose toothed discs pro-

- vide longitudinal grooves on the surface of the armature for the reception of the armature coils.
- Toothed-Core Discs.**—The discs employed in a toothed-core armature.
- Toothed-Drum Armature.**—A drum-shaped form of toothed-core armature.
- Toothed-Ring Armature.**—A ring-shaped form of toothed-core armature.
- Top-Hat Curve.**—A curve of electromotive force, current or flux which has the shape of a top hat, that is, in which the value is fairly constant for a considerable time at its maximum rise and fall.
- Topler-Holtz Machine.**—A form of electrostatic induction, or influence, machine.
- Torch Signalling.**—A form of flash signalling.
- Tore.**—A toroid.
- Toroid.**—A solid of revolution bounded by a surface generated by revolving any closed plane curve about an axis in its plane which does not cut it.
- Toroidal Coil.**—(1) A coil wound in the form of a toroid. (2) A closed circular solenoid.
- Toroidal Current-Sheet.**—A uniform current-sheet having the form of a toroid.
- Torpedo Boat.**—A boat used for carrying and discharging torpedoes.
- Torpedo Cable.**—(1) A cable in the circuit of which a torpedo fuse is placed. (2) A cable designed for use with a torpedo.
- Torpedo, Electric.**—(1) A name sometimes given to an electric ray. (2) An electrically operated torpedo.
- Torpedo Nets.**—Steel-wire netting suspended from or attached to a ship's side for the purpose of ensuring protection against moving torpedoes.
- Torque.**—(1) The moment of a force applied to a dynamo or other machine which causes its rotation. (2) The mechanical rotary or turning force which acts on the armature of a dynamo-electric machine, or motor, and causes it to rotate. (3) The ratio of the mechanical activity of a motor, at its belt or pulley, to the angular velocity.
- Torque Efficiency.**—The ratio of the torque exerted by a motor at a given input or terminal electric activity, to the torque it would exert if it were a perfect machine and had no loss of energy.
- Torqueless Stress.**—A twistless stress, or stress which produces no torque.
- Torricellian Vacuum.**—The vacuum which exists above the surface of the mercury in a barometer tube, or other vessel over thirty inches in vertical height, which has been filled with boiled mercury and inverted below the surface of the mercury in a vessel.
- Torsibility.**—Possessing the ability of being tersed or twisted.
- Torsion.**—The twisting of a body by the application of a torsional force.
- Torsion Galvanometer.**—A galvanometer in which the strength of a deflecting current is measured by the torsion exerted on the suspension system.
- Torsional Rigidity of Fibres.**—The elastic couple set up in a fibre per unit of twist.
- Torsional Vibration.**—The vibration produced in a solid body by torsion.
- Total Candle-Power.**—A term sometimes used for the total quantity of light emitted by any luminous source.
- Total Contact.**—A full or metallic contact.
- Total-Current-Panel of Switchboard.** That panel of a switchboard which is provided with devices for measuring and controlling the total current generated by a station.
- Total Disconnection.**—(1) Any disconnection effected by the opening of a switch or the actual breaking of a circuit. (2) A complete loss of continuity in a circuit.
- Total Earth.**—A term sometimes used for dead earth.
- Total Efficiency of Luminous Source.** The ratio of the luminous rays to the total energy expended.
- Total Intensity of Earth's Magnetism.** (1) The resultant or entire force of the earth's magnetism, as distinguished from the horizontal or vertical components. (2) The flux density of the earth's magnetism.
- Total Magnetic Induction.**—(1) The number of lines of magnetizing force which pass through any space where magnetizable material is placed, together with the lines added by the magnetization of the magnetic material. (2) Total magnetic intensity, or induction density, in a magnetized substance.
- Total Resistance.**—The sum of the resistances of a circuit.
- Tourmaline.**—A crystalline body consisting of natural silicates and borates of alumina, lime, iron, etc., possessing pyroelectric properties.

- Tourniquet, Electric.**—A term sometimes used for an electric flyer.
- Tower, Electric.**—A high tower, provided in systems of tower illumination, for the support of a number of electric arc-lamps.
- Tower-System of Electric Lighting.**—The lighting of extended areas by means of arc lights placed on the tops of tall towers.
- Tower Wagon.**—The repair wagon employed on trolley lines, and provided with a structure for enabling the workmen to conveniently reach the trolley wires.
- Towing, Electric.**—Electric hauling of canal boats.
- Towing Torpedo.**—A torpedo arranged to be towed after a vessel, and exploded when it strikes the side of an enemy's vessel.
- Track Bond.**—A rail bond.
- Track Instrument.**—An electric contact capable of being closed by a train moving over it, placed by the side of a railroad track, and employed to sound an alarm or indicate at a distance the presence of the train.
- Track Joint.**—A rail joint.
- Track Switch.**—(1) A switch for leading a car from one track to another. (2) A mechanical switch in the rail of a street-car track for changing the route of a car.
- Track-to-Dynamo Bonding.**—A method of bonding in which a track of positive polarity is bonded to the negative side of a dynamo.
- Traction, Electric.**—The propulsion of a car, or other vehicle, by the action of an electric motor.
- Trailer.**—(1) An ordinary car attached to a trolley car and drawn after it. (2) Any car hauled by a motor car.
- Trailer Grapnel.**—A second or following grapnel attached to and travelling behind an ordinary grapnel.
- Trailing Pole.**—(1) The following pole edges of a dynamo-electric machine. (2) The pole edges of a dynamo-electric machine, from which a point on the surface of the armature moves when midway between the poles.
- Train Describer.**—(1) An electric contrivance arranged for automatically indicating the position of trains on a railroad. (2) In a system of block signalling by electricity, an instrument for indicating at a distance the character of a train which is being sent along the line.
- Train Wire.**—A line wire connected with the general dispatcher's office, employed in a block system of railroads, and used for sending train orders only.
- Trajectory.**—(1) The curve described by a projectile thrown obliquely upwards. (2) A curve which cuts, according to a given law, a system of curves obtained by varying a parameter.
- Tramcar, Electric.**—A term applied to an electric trolley car.
- Tramway, Electric.**—A term applied to an electric railway.
- Trans-Continental Telephony.**—Telephonic communication established across a continent.
- Transfer Board.**—In telephony, a switch-board at which calls are transferred from one junction line to another.
- Transfer Bus-Bar.**—A bus-bar that is employed to gradually transfer a feeder from one bus-bar to another, without the sudden variation of potential which would occur if it were thrown over directly.
- Transfer Operator.**—In telephony, an operator at a transfer board.
- Transform.**—(1) To change or convert. (2) To change or convert the electromotive force, and, consequently, the current strength in a circuit, by any means. (3) To change the type of a current, as from an alternating into a continuous current.
- Transformation.**—The act of transforming or changing.
- Transformation of Electromotive Force or Current.**—A change in the value of an electromotive force or current by any means.
- Transformation of Electric Force.**—(1) Transformation of electromotive force. (2) Transformation of electric energy into some other form of energy.
- Transformation of Heat.**—Transformation of heat energy into any other form of energy.
- Transformer.**—An induction coil employed either for raising or for lowering electric pressure.
- Transformer Connection Board.**—A board employed on a transformer for ease in changing or inter-connecting its circuits.
- Transformer Controller.**—(1) An apparatus for operating or controlling a transformer. (2) A controller of pressure operated on the principle of an alternating-current transformer.
- Transformer Fuse.**—A fuse employed either in the primary or secondary circuit of a transformer.

Transformer Fuse-Block.—A fuse-block in or near a transformer case.

Transformer Guard.—(1) A transformer lightning-guard. (2) Any device for automatically grounding the secondary of a transformer on its accidental contact with the primary.

Transformer Indicator-Diagram.—A set of diagrams automatically recorded on a card, which give the instantaneous values of the current and electromotive force of a transformer circuit.

Transformer Lightning-Arrester.—A form of lightning arrester designed for the protection of transformers.

Transformer Lightning Guard.—A transformer lightning-arrester.

Transformer Motor.—An induction motor.

Transformer Secondary Connection Board.—A separate transformer connection board provided for its secondary circuits.

Transformer Stampings.—Sheet steel stampings of such shape as is suitable for building up the laminated core of a transformer.

Transformer Sub-Station.—A sub-station where a number of transformers are grouped, designed as a sub-centre of distribution.

Transforming.—(1) Changing electric energy from lower pressure and higher current to higher pressure and lower current or *vice-versá*. (2) Changing the character of a current.

Transforming Currents.—Changing the value of the current strength in any circuit, with a corresponding opposite change in pressure.

Transforming Down.—Lowering the pressure in a distribution circuit by means of a step-down transformer.

Transforming Station.—(1) In a system of distribution by transformers, a station other than a central station, where a number of transformers are placed in order to supply a group of houses in that neighborhood. (2) A transformer sub-station.

Transforming Up.—Raising the pressure in a distribution circuit, by means of a step-up transformer.

Transient.—(1) Momentary. (2) Lasting or enduring but for a short time.

Transient Currents.—Currents that are of but momentary duration.

Transient Magnetomotive Force.—(1) A momentary magnetomotive force. (2)

A magneto-motive force produced by the momentary passage of an electric current.

Trans-Illumination.—Such an illumination of an interior cavity of the body as to permit it to be visible through the intervening portions of the body as a translucent screen.

Transition Layer.—A layer marking the separation of two homogeneous bodies at which the electric or magnetic properties pass with great rapidity from one value to another.

Transition Resistance.—(1) A term sometimes used in electro-therapeutics for a change in the value of a resistance caused by polarization. (2) Resistance residing in the contact surface between a solid and a liquid, or between two solids.

Translator.—A telegraphic translator or repeater.

Translating Commutator.—A term sometimes used for translation commutator.

Translating Device.—A name frequently given to an electro-receptive device.

Translating Telegraphic Station.—(1) A receiving station. (2) Any station at which a telegraphic message is automatically repeated into another circuit.

Translation Commutator.—A name sometimes given to a switch on a translating board.

Translation Lag.—A lag due to the traverse of an active conductor past a magnet pole, whereby the current in the conductor is displaced in the direction of the motion, and produces a moving field, the iron mass or body tending to accommodate itself to the direction of the flux in the moving field.

Translator.—An orthography for translator.

Translator Keys.—Keys employed in a translator for signalling on either circuit.

Translucence.—Possessing the property of transmitting light but of preventing the outlines of objects from being seen.

Translucent.—Possessing the property of translucence.

Translucent-Disc Photometer.—A photometer in which the light to be measured is placed on one side of a partly translucent and partly opaque disc, and the standard candle, or other photometric standard, is placed on the opposite side, the intensity of the light being estimated by the distance of the lights from the disc, when an equal illumination is obtained over both surfaces.

Transmission Circuit, Electric.—The circuit employed to receive the apparatus necessary in any transfer of electric energy from the generators to the receptive devices.

Transmission Dynamometer.—A dynamometer in which the mechanical power that is measured is transmitted to some machine, as distinguished from a dynamometer which measures and at the same time absorbs the energy.

Transmission, Electric.—The transference of energy from one point to another by means of electric currents.

Transmission Insulator.—(1) An insulator employed on transmission lines. (2) A high-tension insulator.

Transmission Line.—A transmission circuit.

Transmission of Energy.—The transference of energy from one point to another.

Transmission of Electric Energy.—The transference of electric energy from one point to another.

Transmitted Power.—Power that is transferred from one point to another.

Transmitter, Electric.—(1) A general name applied to the various electric apparatus employed in telegraphy or telephony to transmit or send electric impulses over a line wire or conductor. (2) Any electric-transmitting instrument, as distinguished from a receiving instrument.

Transmitting Magnet.—The magnet employed in any transmitting instrument.

Transmitting Station.—A station from which any electric signals or impulses are sent.

Transposing.—In a system of telephonic communication, a device for avoiding the bad effects of mutual induction, by alternately crossing equal lengths of consecutive sections of the line.

Transposition.—The transposing of a telegraph or telephone circuit.

Transposition Insulator.—A special form of insulator provided for the ready transposition of a telephone circuit.

Transposition Joints of Telephone Circuit.—The joints employed on a telephone circuit at the transposition insulators.

Transverse Electromotive Force.—An electromotive force excited by a magnetic field in a substance in which electric displacement is occurring.

Transverse Vibration.—A vibration in

an elastic medium in which the successive particles move at right angles to the direction in which the wave is progressing through the medium.

Travelling Derrick.—A derrick supported on guideways, on a platform over which it is movable, provided for shifting or moving heavy masses through short distances.

Travelling Dynamo.—A dynamo mounted on a movable platform.

Travelling Motor.—(1) A motor placed on a movable car or carriage, as distinguished from a stationary motor. (2) A locomotor.

Travelling of Arc.—An unsteadiness produced in the light of a carbon arc occasioned by the shifting of the position of the arc between the electrodes.

Traversing Motor, Electric.—(1) A motor which moves regularly to-and-fro, through a limited distance. (2) In an electrically operated crane, the motor which operates the traverse.

Tread of Car Wheel.—The running face of a car wheel, or the part that comes in contact with the surface of the track.

Treated Coke Filament.—A coke filament of an incandescent lamp that has been subjected to the flashing process.

Tree-System of Parallel Distribution. A system of parallel distribution of incandescent lamps, in which the main conductors of the system resemble the trunk of a tree, and the auxiliary leads branch in various directions, somewhat after the fashion of a spreading tree, the lamps occupying the place of the twigs, leaves and fruit.

Tree Insulator.—(1) An insulator placed on a tree for the support of an aerial wire. (2) A variety of insulator suitable for attachment to trees, and designed so as to keep the conductor in normal position, despite the movement of the tree.

Tree Wire.—A special form of insulated wire designed to resist the abrasion of the insulating substance, when rubbed against a rough surface, like the bark of a tree.

Trega.—A prefix for a trillion, or one million million, or 10^{12} .

Tregadyne.—A trillion dynes, or roughly the weight of a thousand tons.

Tregerg.—One trillion ergs, or 73,730 foot-pounds at Greenwich; or, approximately, 33 foot-tons.

Tregohm.—One trillion ohms, or one million megohms.

- Tregohm Galvanometer.**—A galvanometer which gives unit deflection through a resistance of one tregohm, in circuit with one volt.
- Trembler.**—A name sometimes applied to a trembling bell.
- Trembler Bell.**—A trembling bell.
- Trembling Bell.**—A form of vibrating or automatic make-and-break contact bell.
- Trevelyan Effect.**—A musical note emitted under certain circumstances when a mass of heated copper is supported on thin edges on a block of cold lead.
- Triad Atom.**—An atom whose valency or atomicity is three.
- Triangular Triphase Winding.**—A word sometimes employed for the inter-linked or three-wire triphase.
- Triangular Triphaser.**—A triangularly wound triphaser.
- Tricoro.**—A prefix signifying one trillionth part, or 10^{-12} .
- Tricoro-Ampere.**—The one trillionth of an ampere.
- Tricoro-Parad.**—The one trillionth of a farad.
- Tricron.**—One trillionth of a metre, or 10^{-12} metre.
- Tricrohm.**—The one trillionth of an ohm.
- Trifilar Suspension.**—A suspension supported by three parallel fibres.
- Trigonometrical.**—Of or pertaining to trigonometry, or the science of angles, their relations, and properties.
- Trigonometrical Functions.**—Certain quantities definitely related to angles considered as independent variables.
- Trigonometrically.**—In a trigonometrical manner.
- Trigonometry.**—That branch of mathematical science which treats of angles and their properties, in triangles or otherwise.
- Trimmer.**—A name sometimes given to a man who recarbons electric arc-lamps.
- Trimming a Lamp.**—Re-carboning an arc lamp.
- Trimming a Wire.**—(1) Preparing a wire for jointing or connecting to an instrument. (2) Baring a wire of insulation and cleansing its conducting surface.
- Triode Working.**—A three-way mode of telegraphic working by the Delany synchronous multiplex telegraphic system.
- Trip Indicator.**—A form of indicator in which the indicator arm or drop is disengaged by the tripping action produced by the movement of the armature of an electro-magnet.
- Triphase.**—A word frequently employed for three-phase.
- Triphase Armature.**—A three-phase armature.
- Triphase Armature-Windings.**—Three-phase armature windings.
- Triphase Circuit.**—A three-phase circuit.
- Triphase-Current.**—A three-phase current.
- Triphase Dynamo.**—A dynamo capable of producing three-phase currents.
- Triphase Generator.**—A triphase dynamo.
- Triphase Motor.**—A motor capable of being operated by triphase currents.
- Triphase Rotary-Field.**—A rotary field produced by the simultaneous action of triphase currents.
- Triphase Rotary-Transformer.**—A rotary transformer operated by, or producing three-phase currents.
- Triphase Rotating-Magnetic Field.**—A triphase rotary field.
- Triphase Transformers.**—(1) Three separate transformers employed for changing the pressure on triphase circuits. (2) A single transformer having three separate triphase windings.
- Triphase Alternating-Currents.**—Three uniphase alternating-currents whose phases are displaced with regard to one another by one-third of a cycle.
- Triphaser.**—A triphase generator.
- Triple-Carbon Arc-Lamp.**—An arc-lamp in which three carbon electrodes are used.
- Triple Connector.**—A connector suitable for uniting the ends of three wires.
- Triple Petticoat Insulator.**—An aerial line insulator provided with a triple petticoat.
- Triple-Pole Single-Throw Switch.**—A single-throw switch having three blades, and intended for closing three circuits simultaneously.
- Triple-Pole Switch.**—(1) A switch consisting of a combination of three separate switches for opening or closing three circuits at the same instant. (2) A switch employed to open or close three contacts. (3) A switch employed to open or close triphase circuits.
- Triple-Truck Support.**—(1) A support for a car body, consisting of three separate trucks. (2) A radial-truck support

- Triplex Telephony.**—(1) The simultaneous telephonic transmission of three distinct messages over the same wire in the same direction.
- Triply Re-Entrant Armature Winding.**—An armature winding provided with three independent conducting paths or windings each of which is separately re-entrant.
- Tripod Roof Support.**—A roof-top support for a telegraph line, in the shape of a tripod.
- Tripping Coil.**—A coil forming part of the mechanism of a circuit-breaker on the switchboard of a central railroad station, so arranged that when the current has reached a certain predetermined value, limited by the action of a spring, the tripping mechanism is operated, thus breaking the circuit.
- Trivalent.**—Possessing an atomicity or valency of three.
- Trolley.**—A rolling contact-wheel that moves over a trolley line and carries off the current required to drive the motor cars.
- Trolley Base.**—A base provided for the support of a trolley pole, and furnished with springs to preserve a firm contact between the trolley and the trolley wire, and also provided with a swivel joint for readily reversing the direction of the trolley pole.
- Trolley Base-Frame.**—A trolley base.
- Trolley Bus-Bar.**—In a railway power station, the bus-bar connected with the trolley system, as distinguished from the bus-bar connected with the ground.
- Trolley Car.**—A motor car in a system of electric railroads employing a trolley system.
- Trolley Car-Controller.**—(1) A series-parallel controller. (2) A car-controller.
- Trolley-Contact.**—The contact secured between a trolley and the trolley wire.
- Trolley-Cord.**—The cord attached to the trolley pole or mast for removing it from and placing it on the line.
- Trolley-Crossing.**—(1) An insulating device, placed at the crossing of two trolley wires, by which the trolley, while running on one line may cross the other without coming into electrical contact with it. (2) A plate supported at the crossing of two trolley wires with guides to assist the trolley wheel across it.
- Trolley Crossing-Ear.**—An ear employed at a trolley crossing.
- Trolley Cross-Over.**—(1) An arrangement for suspending the trolley wires at a trolley crossing. (2) A trolley crossing.
- Trolley Ear.**—A metal piece supported by an insulator, to which the trolley wire is fastened.
- Trolley Fork.**—The mechanism which mechanically connects the trolley wheel to the trolley pole.
- Trolley Frog.**—(1) The device to which the trolley wire is attached, employed for causing a car to deviate from one line to another. (2) A name given to the device employed in fastening or holding together the trolley wires at any point where the wires branch, and properly guiding the trolley along the trolley wire on the movement of the car over the track, under the action of the track switch.
- Trolley Guard.**—A trolley wire guard.
- Trolley Hanger.**—A device for supporting and properly insulating a trolley wire.
- Trolley Harp.**—The metallic frame placed on a trolley fork for supporting the trolley wheel.
- Trolley Ice-Clearer.**—A form of trolley wheel suitable for removing ice or sleet from a trolley wire.
- Trolley Insulator.**—A name sometimes applied to a trolley ear.
- Trolley Insulated Crossing.**—An insulated trolley crossing.
- Trolley Mast.**—A term frequently used for trolley pole.
- Trolley Mechanism.**—(1) The device employed for carrying the current from the trolley line to the motor in the car. (2) A general mechanism, including the trolley base, pole, wheel and rope.
- Trolley Pole.**—A pole, or mast, of wood or metal supporting the trolley and employed to carry a conductor from the car to the trolley wire.
- Trolley Section.**—(1) A single continuous length of trolley wire. (2) A portion of a trolley line insulated from adjoining portions and furnished with separate feed wires.
- Trolley Railway.**—An electrically operated railroad employing a trolley.
- Trolley Stand.**—(1) A word sometimes used for a trolley base. (2) A support provided for a trolley pole.
- Trolley Strain-Insulator.**—An insulator provided for the support of the strain wires.
- Trolley Strain-Wires.**—Wires employed for attachment to lugs in the anchor strain ear, for the purpose of maintaining the trolley line taut.

- Trolley Switch.**—(1) A switch placed on a track for the purpose of changing the car from one track to another. (2) An overhead switch provided at a turn of a trolley road for guiding the trolley to another line when the frogs on the track beneath have thrown the wheels of the car into another track.
- Trolley Three-Way Frog.**—A trolley frog used where the line branches in three directions.
- Trolley Traction.**—Electric traction by the trolley system.
- Trolley Truck.**—The truck supporting a trolley car and containing the car motors.
- Trolley Two-Way Frog.**—The ordinary V-shaped trolley frog.
- Trolley Wheel.**—(1) A metallic wheel connected with the trolley pole and moved over the trolley wire, for the purpose of taking therefrom the current required for driving the motor car. (2) The trolley.
- Trolley Wire.**—The bare overhead wire employed in a trolley system for supplying the driving current to the car motors through the intervention of the trolley mechanism.
- Trolley Wire Insulator.**—The insulator provided for the support of a trolley wire.
- Trolley Wire Splice.**—A joint or splice employed in joining two ends of trolley wires, consisting essentially in slipping the ends in a tubular conductor and then brazing them.
- Trop.**—A proposed unit of entropy equal to the quotient of one joule divided by one degree Centigrade.
- Truck for Car Motor.**—A support provided with wheels, and employed either singly, or in connection with one or more similar trucks, for the support of the car body.
- True Contact Force.**—The force or effect, distinguished from the voltaic effect which exists at the points of contact between two dissimilar metals.
- True Galvanometer Constant.**—The intensity of the field produced at the centre of a galvanometer coil by a unit current flowing through the coil.
- True Ohm.**—(1) An ideal ohm having the true theoretical value. (2) A term sometimes applied to the International ohm in contradistinction to the B. A. or legal ohm.
- True Power.**—In an alternating-current circuit the power which is represented by the true watts, as distinguished from the apparent power, or that represented by the apparent watts.
- True Resistance.**—The resistance which a conductor offers to the passage of a current, by reason of its dimensions and resistivity, as distinguished from the spurious resistance produced by a counter electromotive force.
- True Watts.**—The activity in an alternating-current circuit, as given by the reading of a correctly calibrated wattmeter connected with such circuit.
- True Zero.**—An instrument or scale zero, as distinguished from a false zero of a galvanometer.
- Trumpet, Electric.**—An electro-magnetic buzzer whose sound is strengthened by a trumpet-shaped resonator.
- Trunion Screws.**—A pair of screws whose opposed points form the pivots of a movable shutter, armature, or other rotating device.
- Trunk Call.**—A telephone call transmitted through a trunk wire.
- Trunk Connection.**—A telephonic connection established through a trunk wire.
- Trunk Junction-Board.**—A junction telephone switchboard for trunk wires.
- Trunk-Line Wires.**—(1) Through wires extended between two distant stations, provided with receiving and transmitting instruments at their ends only. (2) In telephony, main line wires connecting two terminal offices for connection to sub-offices or subscribers. (3) A main line wire connecting two important terminals for receiving telephone traffic.
- Trunk-Line Working.**—Telephone working embracing the use of trunk lines between central stations, as distinguished from lines connecting a central station with subscribers.
- Trunk Operator.**—In telephony, an operator at a trunk switchboard.
- Trunk Switchboard.**—In telephony, a switchboard at which trunk lines terminate.
- Trunk Wire.**—(1) A trunk line wire. (2) A main telephone wire. (3) A connecting wire running from town to town, or exchange to exchange, as distinguished from a wire connected permanently to a subscriber.
- Trunk Working.**—Telephonic or telegraphic transmission by means of trunk line-wires.
- Trunking-Out Telephone Switchboard.**—A form of telephone switchboard employed in long-distance working.

- Trunking Switchboard.**—A switchboard in which a few subscribers only are connected to the operator, thus enabling him to obtain any other subscriber by means of trunk wires extending to other sections.
- Trunking Telephone System.**—(1) A system of telephony employing trunk wires. (2) A system of telephony in which multiple switchboards are dispensed with, and all calls are trunked from the incoming to the outgoing panel.
- Trussed Pole.**—A pole which has been strengthened against lateral pull by the use of an outrigger and stays.
- Trussed Standard.**—A standard which has been strengthened to resist lateral stresses by the use of an outrigger and stays.
- Tube of Flow.**—A word sometimes used for a tube of force.
- Tube of Force.**—An imaginary tube in electrified or magnetized space, bounded by lines of electrostatic or magnetic force, and intersected by equipotential surfaces.
- Tube of Induction.**—In a space occupied by magnetic induction, an imaginary tube of induction flux bounded by induction lines.
- Tube of Magnetic Force.**—In magnetized space, a tube bounded by lines of magnetic force.
- Tubular Annunciator Drop.**—A special form of telephone annunciator-drop in the shape of a tube, and provided with an iron-clad magnet.
- Tubular Braid.**—A braid of fibrous insulating material, woven in the form of a tube, and provided for drawing over a joint after the two wires have been connected.
- Tubular Conductors.**—Conductors in the shape of tubes.
- Tubular Connectors.**—Connectors in the shape of tubes.
- Tubular Current.**—(1) A term sometimes applied to the current that traverses the superficial portions only of a solid conductor. (2) A current flowing through a tube, or having a distribution such as would be produced by flow through a tube.
- Tubular Electro-Magnet.**—An electro-magnet of a tubular form.
- Tubular Magnet.**—(1) A magnet in which a single coil enclosing a core is surrounded by an iron cylinder connected to the core at one end by an iron base or yoke. (2) A form of iron-clad magnet.
- Tumbler Switch.**—A switch provided with a double-contact knife-blade which can be readily depressed by the movement of a bolt lever placed at the top.
- Tumbling Box.**—(1) A rotating box in which metallic articles that are to be electro-plated are placed, so as to be polished by attrition against one another. (2) A rotating box in which rough castings are placed for smoothing their surfaces by attrition.
- Tuning-Fork Dynamo.**—An oscillatory dynamo.
- Tuning-Fork Interrupter.**—A reed interrupter.
- Tuning of Electric Circuit.**—Altering the period of a circuit, or varying either its capacity or self-induction, so as to bring it in resonance with another circuit.
- Tunnel Armature.**—An armature of a dynamo-electric machine in which the conductors are placed in holes, or nearly closed grooves, beneath the external surface of the core.
- Turnbuckle.**—(1) An appliance for straining span wires. (2) A screw tightener for a rod, guy, or line.
- Turn-Out.**—(1) A short section of single track which allows two cars to pass one another on a single track line. (2) A short side section placed at a station on a single-track road for switching a car off the main line so as to leave it clear.
- Turn-Table, Electric.**—A table suitable for show-windows revolved around a vertical axis by means of an electric motor.
- Turret-Turning Motor.**—A motor employed on board a war-ship for turning a gun turret.
- Turtle-Back Electro.**—A curved electrotype employed for use in cylindrical presses.
- Twigs.**—(1) A term sometimes applied to the branches or conductors connected with the sub-mains in a system of incandescent distribution. (2) Sub-branches.
- Twin-Carbon Arc-Lamp.**—A double-carbon arc-lamp.
- Twin Conductors.**—Two parallel conductors, laid side-by-side, and covered by a simple coating of braid.
- Twin Filament Lamp.**—A double-filament lamp.
- Twin Wire.**—A conductor consisting of two separate conductors bound together by an insulating covering.
- Twin-Wire Circuit.**—A circuit formed of twin conductors.

- Twist System.**—A system of running overhead wires for the purpose of destroying mutual inductive disturbances, and consisting in giving to the wires a helical twist as they run.
- Twist in Armature Leads.**—A displacement of the ends of the armature wires connected with the commutator segments, as regards the position of the coils on the armature, for the purpose of obtaining a more convenient position for the diameter of commutation, and, consequently, for the points of contact of the collecting brushes on the commutator.
- Twist in Leads.**—A twist given at regular intervals, to the leads of twin conductors, for the purpose of avoiding the effects of induction.
- Twisted Bunched-Cable.**—A bunched cable, the separate conductors of which consist of twisted pairs placed in successive layers.
- Twisted Double-Conductors.**—A pair or a number of pairs of twisted twin conductors.
- Twisted Pair Cable.**—A cable containing one, several, or many twisted pairs of conductors, suitable for metallic circuits.
- Twisted Pairs of Conductors.**—An assemblage of twisted pairs of conductors, for metallic circuits.
- Twisted Strip-Voltmeter.**—A voltmeter consisting of a twisted strip of platinum-silver, and operating by the tendency of the strip to coil or uncoil when its temperature is changed by the passage through it of the current to be measured.
- Twisted Wire-Clip.**—A clip formed of a twisted wire.
- Twisted Wires.**—A term sometimes employed for transposed aerial telephone wires.
- Twisting Force.**—A term sometimes used for torque.
- Two-Bearing Generator.**—A generator whose rotor is provided with but two bearings, as distinguished from a three-bearing generator.
- Two-Bearing Motor.**—A motor whose rotor is provided with but two bearings, as distinguished from a three-bearing motor.
- Two-Circuit Armature-Winding.**—An armature winding which provides only two circuits through an armature between the commutator brushes, no matter how great may be the number of poles.
- Two-Circuit Dynamo.**—A dynamo provided with a two-circuit armature winding.
- Two-Circuit Multiple-Winding.**—A multiple winding on an armature, each component of which offers two circuits to the current.
- Two-Circuit Single-Wound Armature.**—A single-wound armature possessing two circuits independently of the number of poles and distinguished by the fact that the pitch is always forward.
- Two-Coil Armature-Winding of Alternator.**—A winding providing two slots in drum armatures or two coils in ring armature, for each and every pole in the field frame.
- Two-Coil Armature-Winding of Multiphase Alternator.**—A winding providing two slots in drum armatures, or two coils in ring armatures, per phase, for each and every pole in the field frame.
- Two-Fluid Voltaic Cell.**—A double-fluid voltaic cell.
- Two-Layer Armature-Winding.**—(1) A winding which is essentially applied in two layers. (2) A winding having more than two layers, but which would be capable of application in two layers only.
- Two-Liquid Cell.**—A term sometimes used for double-fluid cell.
- Two-Part Commutator.**—A commutator containing two segments suitable for commuting currents in a single coil rotated in a bipolar field.
- Two-Phase Alternator.**—A diphasic alternator.
- Two-Phase Armature.**—A diphasic armature.
- Two-Phase Circuit.**—A diphasic circuit.
- Two-Phase Dynamo or Generator.**—A diphasic generator.
- Two-Phase Motor.**—A diphasic motor.
- Two-Phase Rotary-Transformer.**—A diphasic rotary transformer.
- Two-Phase-Three-Phase Transformer.**—An alternating-current transformer for transforming from two-phase currents to three-phase currents.
- Two-Phase Transformer.**—A diphasic transformer.
- Two-Phase Working.**—Transmitting electric power by means of diphasic currents.
- Two-Phaser.**—(1) A generator of diphasic or quarter-phase alternating-currents. (2) A diphaser.
- Two-Point Switch.**—A switch by means of which a circuit can be completed through two different contact points.
- Two-Point Trolley Switch.**—A trolley

switch provided for a bifurcation in a road.

Two-Pole Dynamo-Electric Machine.

A dynamo-electric machine whose field is produced by two poles.

Two, Three, or Four-Conductor Cable.

A cable containing two, three or four separate conducting wires.

Two-Way Door-Trigger.

A trigger which operates both when the door is opened and when it is closed.

Two-Way Splice-Box.

A splice box provided with two tubular conduits or ways.

Two-Way Switch.

A switch provided with two contacts connected with two separate and distinct circuits.

Two-Wire Distributing Board.

A distributing board for metallic circuits.

Two-Wire Incandescent Lighting.

Incandescent lighting from a single pair of mains, as distinguished from three-wire incandescent lighting.

Two-Wire Mains.

A name for the mains employed in the ordinary system of multiple distribution, as distinguished

from a three-wire main, or that used in a three-wire system.

Two-Wire Moulding.

A moulding provided with two grooves, and employed for the reception of two-wire mains or branches.

Two-Wire Multiple-Switchboard.

A multiple telephone switchboard in which the jacks of a subscriber's circuit are connected by two wires.

Two-Wire Switchboard.

A telephone switchboard with two-wire connections.

Tying-In of Line Wire.

Securing a line wire to its insulator.

Type-Printing Telegraphy.

Printing telegraphy.

Type-Printing Telegraphic Transmitter.

A transmitter employed in printing telegraphy.

Typewriter, Electric.

A typewriting machine in which the keys are only intended to make the contacts of circuits of electro-magnets, the attractions of whose armatures cause the movement of the type levers required for the work of printing.

U

U.—A contraction sometimes employed for unit.

Ultimate Capacity of Switchboard.

The total number of subscribers that a multiple telephone switchboard can be made to accommodate.

Ultimate Optical Efficiency.

A term sometimes employed for the conditions required to ensure the greatest efficiency in the observation of small angular deflections of a suspended mirror by properly proportioning the dimensions of different parts of the system.

Ultra-Gaseous Matter.

(1) The peculiar condition of the matter which constitutes the residual atmospheres of high vacua. (2) Radiant matter.

Ultra-Incandescent Lamp.

An incandescent lamp in which the filament is covered with oxides of thorium, etc., so that their radiative powers are utilized by the glowing filament.

Ultra-Thermal Lightning Arrester.

An arrester for protecting instruments from unduly powerful currents, operated by the expansion of a metallic wire placed in the line circuit.

Ultra-Ultra-Violet.

A term proposed for luminous frequencies far beyond the violet in the spectrum.

Ultra-Violet Rays.

A term proposed for rays whose frequencies are greater than that of violet light.

Ultra-Violet Spectrum.

That portion of the spectrum which lies beyond the violet, or whose frequencies are greater than that of the violet.

Umbrella Type of Generator.

A type of generator in which an umbrella-shaped rotor is revolved around the stator or stationary element.

Umbrella Springs.

In telephone switchboard plugs, contact-springs pressing out sideways from the plug, like umbrella springs.

Unbalanced Load.

In a system of electric distribution, a load whose distribution is unsymmetrical.

Unbalanced Polyphase System.

A polyphase system in which the load and, therefore, the pressures and currents, are not symmetrically distributed.

Unbattery.

(1) To disconnect from a battery. (2) To remove a battery from a car,

- carriage, boat, building, device or receptacle.
- Unbuilding of Dynamo.**—The loss of magnetization of a dynamo field.
- Undemagnetizable.**—A term applied to an electro-magnetic railroad signal, whose signals are irreversible by atmospheric causes.
- Underframe.**—A truck of an electric motor car.
- Underground Cable.**—A cable suitable for being placed underground.
- Underground-Cable Support.**—(1) Any support provided in a subway for holding an underground cable. (2) A support provided for holding a cable where it passes around the side of a manhole, underground conduit, or other similar location.
- Underground-Cable Terminal.**—(1) The place where an underground cable emerges from the ground. (2) A cross-connecting or distributing board placed where an underground cable enters or leaves the ground, in order to facilitate the making and changing of the connections.
- Underground Conductor.**—An electric conductor placed underground, either by actual burial, or by passing it through underground conduits or subways.
- Underground Electric Conduit.**—(1) An underground pipe or tube provided with a number of separate ways or ducts for the reception of electric wires or cables. (2) An underground passage-way or space provided for the reception of electric wires or cables.
- Underground Electric Tube.**—An iron pipe containing three insulated conductors separated from one another and from the pipe by means of a bituminous insulating substance, employed in connection with the Edison three-wire system of distribution.
- Underground Railway.**—A name sometimes applied to an under-running trolley system.
- Underground Telegraph.**—(1) A telegraph, a large portion of whose circuit consists of underground wires or conductors. (2) A telephone cable provided for use underground.
- Underground Telephone Cable.**—A subterranean telephone cable, as distinguished from an aerial telephone cable.
- Underground Trolley System.**—A system of car propulsion in which the trolley wheel is replaced by a plow or sled that is pushed before, or drawn after, the car along a trolley wire placed inside a slotted underground conduit.
- Underground Tube.**—An underground electric tube.
- Under-Running of Cable.**—The operation of passing a shallow-water cable over a boat, barge or vessel for the purposes of examination, by hauling the cable in at the bows, and allowing it to pass out at the same time over the stern; or, simply allowing it to run over a sheave while the boat is urged along the line of cable.
- Under-Running of Incandescent Lamps.**—The operation of incandescent lamps at a pressure below the normal.
- Under-Running Sheave.**—A supported sheave for the admission of a bight of cable, and suitable for use in underrunning as distinguished from a sheave through which an end must be passed.
- Under-Running Trolley.**—(1) A trolley wheel running under a wire in the usual way. (2) A word sometimes used for underground underrunning trolley.
- Under-Running Trolley.**—A system of street-car propulsion in which the trolley wire is suitably supported in an underground slotted conduit, the current being taken off by means of a sled or shoe, pushed before or drawn after the car.
- Undertaker.**—(1) One who supplies electric energy to consumers. (2) A word sometimes used in electric lighting literature for those who are ready to deliver electric energy to consumers.
- Under-Type Magnet.**—A horse-shoe magnet of the vertical type, whose armature is placed near the lower end.
- Undulating Current.**—(1) A name sometimes given to an undulatory current. (2) A current of constant direction but continuously varying strength.
- Undulation.**—A wave or vibration, especially electric.
- Undulator.**—A form of rotating commutator employed for the use of transformers on continuous-current circuits. (2) A commutating device for the operation of alternating-current apparatus from a continuous-current circuit.
- Undulatory Currents.**—Currents of constant direction whose strength gradually changes.
- Undulatory Discharge.**—(1) A discharge whose strength gradually changes without change of direction. (2) A term sometimes used for an oscillatory discharge.
- Undulatory Winding.**—A name frequently given to a wave winding.

- Unevenly Distributed Armature Winding.**—A winding in which the slots do not recur at equal intervals around the periphery of the armature.
- Unflashed Filament.**—A lamp filament that has not been subjected to the flashing process.
- Unfooting.**—A layer of broken stone, gravel and concrete, placed in layers and rammed, and employed at the bottom of a foundation trench for receiving the masonry work.
- Ungilding Bath.**—A stripping bath suitable for the removal of a coating of gold.
- Uni-Coil Alternating-Current Armature-Winding.**—A winding providing one slot or coil on the armature for each and every pole in the field frame.
- Uni-Coil Multiphase Armature-Winding.**—A multiphase armature winding providing one slot or coil per phase for each and every pole in the field frame.
- Uni-Directed Currents.**—(1) Currents that have been caused to take the same direction by means of a commutator. (2) Commuted currents.
- Uni-Directed Electromotive Forces.** Unidirectional electromotive forces.
- Unidirectional.**—Possessing the same direction.
- Unidirectional Discharge.**—An electric discharge which preserves the same direction from the beginning to the end of the discharge.
- Unidirectional Electromotive Forces.** Similarly directed electromotive forces.
- Unidirectional Leak.**—A gradual loss or leakage of electricity which takes place in the same direction.
- Unifilar Suspension.**—Suspension by means of a single wire or thread.
- Uniform Density of Field.**—A field in which the density is the same in all equal areas of similar cross-section.
- Uniform Flux.**—Uniform magnetic-flux.
- Uniform Magnetic-Field.**—(1) A field of uniform density. (2) A field traversed by the same number of lines of magnetic flux in all portions of area of normal cross-section. (3) Magnetic flux in straight lines and of uniform density.
- Uniform Magnetic Filament.**—A term sometimes applied to a magnetic filament.
- Uniform Magnetic Flux.**—(1) A magnetic flux whose density is everywhere the same. (2) The flux of a uniform magnetic-field.
- Uniform Magnetization.**—Such a magnetization of a rectangular or cylindrical bar that equal areas of normal cross-section are traversed by the same quantity of magnetic flux.
- Uniform Potential.**—(1) A potential whose value does not vary from point to point. (2) A constant potential.
- Uniformly Distributed Current.**—(1) A term sometimes employed in the sense of a steady current. (2) A current having the same density at all points in a cross-section of a conductor.
- Unigraph.**—A portable form of sending and receiving Morse instrument in one piece.
- Uninsulated Return.**—(1) A return which employs the earth only as a return circuit. (2) An earth-return.
- Uni-Periodic Current.**—An alternating current of a single frequency, as distinguished from a multi-periodic current.
- Uniphase.**—Single phase.
- Uniphase Alternator.**—An alternator that produces uniphase currents.
- Uniphase Armature.**—The armature of a uniphase alternator.
- Uniphase Armature-Winding.**—Such an armature-winding as will produce uniphase alternating-currents.
- Uniphase Circuit.**—Any circuit through which uniphase or single-phase currents are passing.
- Uniphase Dynamo.**—A uniphase alternator.
- Uniphase Generator.**—A uniphase alternator.
- Uniphase Motor.**—An electric motor capable of being operated by uniphase currents.
- Uniphaser.**—A term sometimes employed for a uniphase alternator.
- Uniplanar.**—Confined to a single plane.
- Unipolar.**—Possessing a single pole.
- Unipolar Alternator.**—An alternator provided with a so-called single magnetic pole.
- Unipolar Armature.**—A dynamo-electric machine armature whose polarity is not reversed during its rotation in the field of the machine.
- Unipolar Dynamo.**—(1) A dynamo provided with a unipolar armature. (2) A commutatorless, continuous-current dynamo.
- Unipolar Electric Bath.**—An electrotherapeutic bath in which the water forms one of the electrodes of the source,

and the other electrode is attached to a metal rod fixed at a convenient height above the body.

Unipolar Induction.—(1) A term sometimes applied to the induction that occurs when a conductor is so moved through a magnetic field as to continuously cut its lines of force. (2) The induction that occurs in a commutatorless, continuous-current dynamo.

Unipolar Magnet.—A term proposed for a magnet in the shape of a long bar, one pole of which lies in the axis of rotation, the axis being placed near to the other pole which is balanced by a counterpoise.

Unipolar Stimulation of Nerve.—The stimulation of a nerve produced by the application of a single electrode to that nerve.

Uni-Slot Armature-Winding or Alternator.—An alternator armature-winding in which a single slot is provided for each and every pole in the armature frame.

Unit Angle.—(1) A radian. (2) An angle equal to 57.29578° ; or, $57^\circ 17' 44.8''$ nearly. (3) A degree, minute, second, grad, radian or other unit of angular measure.

Unit Angular Velocity.—(1) A radian per second. (2) The velocity under which a particle moving in a circular path whose radius is equal to unity, would traverse unit angle in unit time. (3) Any angular velocity which describes a unit angle in unit time.

Unit Difference or Potential of Electromotive Force.—(1) Such a difference of potential between two points that requires the expenditure of one erg of work to bring a unit of positive electricity from one of these points to the other, against the electric force. (2) In the practical system of units, the volt.

Unit Jar.—A small Leyden jar sometimes employed to measure, approximately, the quantity of electricity passing into a Leyden battery or condenser.

Unit Magnetic-Pole.—(1) A magnetic pole whose strength is such that it would act on a similar pole at a distance of one centimetre with a force of a dyne. (2) A magnetic pole of unit strength.

Unit of Acceleration.—That acceleration which will give to a body unit velocity in unit time, as for example, a centimetre-per-second per-second.

Unit of Activity.—(1) A rate-of-doing-work that will perform one unit of work in each second. (2) In the C. G. S. sys-

tem, an activity of one erg-per-second. (3) In the practical system, the watt.

Unit of Diviance.—A term proposed for unit of resistance to lines of electrostatic force.

Unit of Electric Quantity.—(1) A unit quantity of electricity. (2) The quantity of electricity conveyed by unit current per second. (3) In the practical system of units, the coulomb.

Unit of Electric Supply.—(1) A unit, provisionally adopted in England by the Board of Trade, equal to a supply of one thousand amperes flowing for one hour under an electromotive force of one volt. (2) The Board of Trade unit, or kilowatt-hour. (3) An amount of electric energy equal to 3,600,000 joules.

Unit of Electric Work.—The joule.

Unit of Electrostatic Capacity.—(1) Such a capacity of a condenser, or conductor, that an electromotive force of one volt will charge it with a quantity of electricity equal to one coulomb. (2) The farad.

Unit of Force.—(1) A force which acting for one second on a mass of one gramme will give it a velocity of a centimetre-per-second. (2) In the C. G. S. system, the dyne.

Unit of Heat.—(1) The quantity of heat required to raise a given weight of water through one degree of the thermometric scale. (2) The British thermal unit or the pound-degree-Fahrenheit; *i. e.*, the amount of heat required to raise one pound of water one degree Fahrenheit. (3) The greater calorie, or the amount of heat required to raise the temperature of one thousand grammes of water one degree centigrade. (4) The smaller calorie, or the amount of heat required to raise the temperature of one gramme of water one degree centigrade. (5) The joule; or the quantity of heat energy developed in a second by the passage of a current of one ampere through the resistance of one ohm.

Unit of Illumination.—The lux.

Unit of Inductance.—(1) A unit of length equal to one centimetre. (2) In the practical system of units, a seohm or quadrant. (3) The henry.

Unit of Light.—Such a light that collected at a single point, would produce unit illumination at unit distance from such point.

Unit of Luminous Intensity.—The British candle; or the intensity of light emitted by a candle, of definite dimen-

- sions and composition, burning at the rate of two grains per minute.
- Unit of Magnetic-Flux.**—The weber; or, the amount of flux which would pass through a magnetic circuit whose reluctance is one oersted, under a magneto-motive force of one gilbert.
- Unit of Magnetic Intensity.**—The gauss; or, a flux density of one weber-per-square-centimetre of normal cross-section.
- Unit of Magnetic Reluctance.**—The oersted; or, the reluctance which is offered to the passage of magnetic flux by a cubic centimetre of air, when measured between parallel faces.
- Unit of Magneto-Motive Force.**—The gilbert; or, the magneto-motive force which is required to act on a circuit in order to cause one weber of flux to pass through it against a reluctance, or magnetic resistance of one oersted.
- Unit of Mass.**—The quantity of matter in a standard gramme.
- Unit of Out-Put of Dynamo-Electric Machine.**—(1) The unit of electric power furnished by the current of a dynamo-electric machine. (2) The kilowatt.
- Unit of Photometric Intensity.**—The intensity of light produced by a candle of given dimensions and composition that consumes two grains per minute.
- Unit of Resistance.**—(1) Such a resistance that unit difference of potential is required to cause the passage of unit current strength through it. (2) In the practical system of units, the ohm.
- Unit of Self-Induction.**—The unit of inductance.
- Unit Quantity of Electricity.**—(1) Such a quantity of electricity as would pass in one second through a circuit whose resistance is one ohm under an electromotive force of one volt. (2) The coulomb.
- Unit Strength of Current.**—(1) Such a strength of current that when passed through a circuit one centimetre in length arranged in an arc of a circle one centimetre in radius, will exert a force of one dyne on a unit magnetic pole placed at the centre. (2) In the practical system of units, the ampere. (3) In the C. G. S. system of units, ten amperes.
- Unit of Power.**—Any unit which measures the rate at which energy is expended, such as the erg-per-second, the foot-pound-per-minute, the kilogramme-metre-per-minute, the horse-power, etc.
- Unit of Twist of a Fibre.**—Such a twist that in unit of length of fibre a unit angular twist is produced.
- Units of Work.**—(1) The erg. (2) A dyne-centimetre, or the amount of work done when a force of one dyne acts through a distance of one centimetre. (3) A foot-pound, or the amount of work required to raise one pound vertically through the distance of one foot.
- Univalent.**—(1) Possessing a valency or atomicity of one. (2) Monovalent.
- Universal Battery System.**—In telegraphy or telephony, a system of employing one battery for the supply of a plurality of circuits.
- Universal Discharger.**—An apparatus for sending the discharge of a Leyden jar, or condenser, through any desired circuit.
- Universal Ether.**—(1) The luminiferous ether. (2) The ether.
- Universal Switch.**—A pin switchboard composed of horizontal and vertical metallic bars capable of inter-connection by means of pins.
- Unlighted Segment of Aurora.**—A term frequently applied to the dark segment of an aurora.
- Unmarked End of Magnet.**—A name formerly applied to the south-seeking pole of a magnet.
- Unmarked Pole of Magnet.**—The south-seeking pole of a magnet.
- Unmarked Magnet Pole.**—A name sometimes given to the south pole of a magnet.
- Unplugging.**—Introducing the resistance of a resistance box into a circuit by the removal of the plug keys,
- Unpolarized.**—Devoid of polarization.
- Unsilvering Bath.**—A stripping bath, suitable for the removal of a coating of silver.
- Unsymmetrical Polyphase Motor.**—A polyphase motor provided with unsymmetrical windings.
- Untreated Filament.**—The filament of an incandescent lamp that has not been subjected to the flashing process.
- Unvarying Current.**—(1) A current whose strength does not vary from time to time. (2) A current of constant strength and direction.
- Up-and-Down-Working.**—In telegraphy, a method of operating consisting of sending a message over the line from each end alternately, as distinguished from batch working.
- Up-Contact of Switch.**—A contact which is made by the upward movement of a switch.

- Up Lines.**—In Great Britain, lines in the direction of the principal station on a circuit, as distinguished from the down lines.
- Up Side.**—In telegraphy in Great Britain, that side nearer to the principal station of a circuit, as distinguished from the down side.
- Upper Harmonics of Current.**—The higher frequencies of a simple-periodic or alternating current.
- Upright Board.**—A telephone switch-board whose surface is vertical, as distinguished from a flat board.
- Upright Galvanometer.**—A galvanometer whose needle moves in a vertical plane.
- Uranium Rays.**—A phrase sometimes employed for Becquerel rays.
- Urban Telephony.**—Telephonic communication between different portions of the same city.
- Urethral Electrode.**—An electro-therapeutic electrode suitable for treatment of the urethra.
- Useful Current.**—A name proposed for the effective current in an alternating-current circuit.
- Useful Life of Incandescent Lamp.**—The time during which an incandescent lamp can furnish practical and operative illumination.
- Utilizing Apparatus.**—Any device by means of which energy may be utilized.

V

- V.**—A contraction for volt.
- V.**—A contraction for volume.
- V.**—A contraction sometimes used for velocity.
- v.**—(1) A symbol employed for the ratio existing between the units of resistance in the electrostatic and magnetic C. G. S. system of units. (2) A velocity ratio.
- V. A.**—A contraction sometimes used for voltaic alternatives.
- Vacuum.**—A space from which all, or nearly all, traces of gas have been removed.
- Vacuum Lightning-Discharger.**—A vacuum lightning protector.
- Vacuum Lightning-Protector.**—A lightning protector employing a vacuum tube for carrying off high-pressure discharges.
- Vacuum Manometer.**—Any manometer whose operation is independent of atmospheric pressure.
- Vacuum Pump.**—An air pump.
- Vacuum-Tube Lighting.**—Artificial illumination obtained by the passage of electric discharges through vacuum tubes.
- Vacuum Tubes.**—(1) Glass tubes in which the air or other gas has been partially removed, and through which electric discharges are passed for the production of luminous effects. (2) A name sometimes applied to Crookes, Roentgen, or other high-vacuum tubes.
- Vaginal Electrode.**—An electro-therapeutic electrode suitably shaped for the treatment of the vagina.
- Valency.**—The combining value of a chemical atom, as regards its power of displacing other atoms in chemical compounds.
- Valve, Electric.**—An electrically-controlled or operated valve.
- Vapor.**—A gaseous substance produced by the action of heat, or by reduction of pressure, on a vaporizable liquid.
- Vapor Globe of Incandescent Lamp.**—A glass globe surrounding the chamber of an incandescent lamp, for the purpose of enabling it to be safely employed in an explosive atmosphere, or to permit it to be exposed in places where water is liable to fall on it.
- Vapor Pressure.**—The pressure at which a liquid changes into a vapor.
- Vaporization.**—The conversion of a volatile liquid into a vapor, either as in evaporation at the surface of a liquid, or throughout its mass, as in ebullition.
- Variable Condenser.**—A term sometimes employed for an adjustable condenser.
- Variable Inductance.**—(1) The inductance of a substance whose magnetic permeability is not constant. (2) An adjustable inductance.
- Variable Period of Electric Circuit.**—That period during which the current strength is rising or falling in a circuit, after the making or breaking of the same, until the current strength is reached or

until the line has been completely discharged.

Variable Period of Electric Current.—The time which is required for an electric current to reach its full strength after the circuit is made, or for reaching zero strength when its circuit has been opened.

Variable Period of Telegraph Line.—The time required for the current in a telegraphic line to reach a constant strength after the circuit through it has been closed.

Variable Ratio Transformer.—An alternating-current transformer whose ratio of transformation is subject to variation.

Variable Resistance.—(1) A resistance, the value of which can be readily varied or changed. (2) An adjustable resistance.

Variable State of Charge on Telegraph Line.—The condition of the charge on a telegraph wire, while the strength of the current is increasing up to its full strength in all parts, or diminishing to zero.

Variation Chart or Map.—(1) A chart or map on which the variations of the earth's magnetism are marked. (2) An isogonic chart.

Variation Magnetometer.—A form of magnetometer suitable for measuring changes in the earth's magnetic variation at any place.

Variation of Declination.—A variation in the magnetic declination of the earth at any place.

Variation of Earth's Magnetism.—Any variation in the value of the magnetic declination or inclination that occurs simultaneously over all parts of the earth.

Variation of Magnetic Needle.—(1) The angular deviation of the magnetic needle from the true geographical north. (2) The declination of the magnetic needle.

Variometer.—(1) An instrument for comparing the horizontal component of the earth's magnetism in different localities. (2) The magnetic variometer.

Varnish, Electric.—A varnish formed of any good insulating material.

Varley's Photometer.—A form of photometer in which the intensity of the light to be measured is determined from the relative openings of two concentric circular diaphragms placed in two rotating discs through which the standard light and the light to be measured respectively pass.

Varley's Unit of Resistance.—The resistance of one statute mile of a special

copper wire $\frac{1}{16}$ th of an inch in diameter. (No longer in use.)

Varying Continuous-Current.—A direct current whose strength varies from time to time.

Varying Undirectional-Current.—A varying continuous or direct current.

Vector.—(1) A directed quantity. (2) A quantity possessing both direction and magnitude.

Vector Diagram.—A diagram representing the relations of vector quantities.

Vector Equations.—Equations connecting vector quantities.

Vector Formula.—A formula containing vector quantities.

Vector Impedance.—The impedance of an alternating-current circuit considered as a vector or directed quantity.

Vector Potential.—A potential possessing direction, as well as magnitude, derived by the process of summation of vectors or elementary directed quantities, as opposed to a scalar potential, or one possessing undirected magnitude.

Vector Quantity.—A quantity possessing both direction and magnitude.

Vector Sum.—The geometrical sum of two or more vector quantities.

Vectorial Algebra.—The algebra of vectors or directed quantities.

Vehicle, Electric.—(1) An electrically-propelled vehicle. (2) An automobile carriage.

Velocimeter.—Any apparatus for measuring the speed of a machine, or velocity generally.

Velocity.—The distance traversed by a body in any time.

Velocity of Discharge.—(1) The velocity with which a liquid or gas escapes from an orifice in a given time. (2) The time required for the passage of a discharge from a given length of conductor.

Velocity of Transmission of Signaling.—The apparent speed of transmission of signals over a telegraph circuit.

Velocity Ratio.—(1) A ratio of the nature of a velocity that exists between the dimensions of the electrostatic and electro-magnetic units. (2) The ratio between the velocities of two mutually associated or interconnected bodies or parts in a machine.

Vena-Contracta.—A contracted vein or conical jet that exists in a jet of water escaping from a circular orifice in the wall of a containing vessel.

- Ventilated Armature-Windings.**—Armature windings provided with means for cooling by forcing currents of air over them.
- Ventilating Duct.**—A ventilating space.
- Ventilating Groove.**—A ventilating space or duct in an armature core.
- Ventilation of Armature of Dynamo or Motor.**—The renewal of air in the armature chamber, due to the passage through it of a stream of air employed for the purpose of preventing too high a temperature elevation during operation.
- Verdet's Constant.**—The magneto-optic constant of a transparent magnetized substance, expressed in angular rotation of the plane of polarization, for a luminous ray of definite frequency at a definite temperature, between points on the ray path whose magnetic potential differs by unity.
- Veriscope.**—A form of bioscope.
- Vernier.**—A device for the more accurate measurement of smaller differences of length or angle than could be detected by the eye alone, by means of the direct reading of the position of a mark on a sliding scale.
- Vernier Caliper.**—A caliper possessing a vernier scale provided for greater precision in observation.
- Vernier Slides.**—A pair of resistance slides one of which is connected in shunt to a pair of contacts on the other.
- Vernier Wire-Gauge.**—A micrometer wire-gauge.
- Vertical Component of Earth's Magnetism.**—That component of the earth's directive force which acts in a vertical direction.
- Vertical Electrostatic Voltmeter.**—A form of voltmeter the needle of which moves in a vertical instead of in a horizontal plane.
- Vertical Galvanometer.**—A galvanometer whose needle is capable of motion in a vertical plane only.
- Vertical Intensity of Earth's Magnetism.**—(1) The vertical component of the earth's magnetism. (2) The force which tends to cause a magnetic needle to assume a vertical position.
- Vertical Magnetic Needle.**—A magnetic needle free to move in a vertical plane only.
- V. Frog.**—A trolley frog shaped like a letter V.
- Vibrating.**—Periodically moving to-and-fro.
- Vibrating Bell.**—A name sometimes given to a trembling bell.
- Vibrating Contact.**—(1) A spring contact connected with one part of a circuit, and so supported as to be able to vibrate towards and from another part of the circuit, thus automatically closing and opening the same. (2) A form of automatic contact-breaker.
- Vibrating Electric Doublet.**—A source of electro-magnetic waves consisting of two equal and opposite oscillating charges concentrated on two small conductors whose distance from each other is indefinitely small in comparison with the distance at which the resulting wave disturbance is considered.
- Vibrating Electrotome.**—An automatic circuit-breaker producing a musical note.
- Vibration.**—A complete to-and-fro movement of a vibrating body.
- Vibration Frequency.**—The number of vibrations produced per second.
- Vibration Needle.**—A tube containing cylindrical weights for attachment to a suspension for measuring the torsional rigidity of the same.
- Vibration Period.**—The period of a single or whole vibration in a conductor in which an oscillatory vibration is being produced.
- Vibrator.**—An electro-magnetic device provided on a siphon recorder for maintaining the siphon in continual vibration, so that ink is thrown from it on a fillet of paper beneath.
- Villari Critical Point.**—A term proposed for that strength of magnetic field at which the reversal of the effects of tension occurs.
- Vine System of Space Relations.**—A system of space relations, usually adopted by electrical writers, which follows the vine tendril; *i. e.*, which considers advance in the direction of a right-handed rotation as positive.
- Violle.**—A unit of luminous intensity produced in a perpendicular direction by one square centimetre of platinum at the temperature of its solidification.
- Violle Lamp.**—The violle.
- Virgin Iron.**—Iron that has never been subjected to magnetization.
- Virtual Amperes.**—(1) Amperes measured in an alternating-current as the square root of the mean square of the current, and determined by an ammeter

- calibrated by constant currents. (2) Effective amperes.
- Virtual Conductance.**—A term sometimes employed for equivalent conductance.
- Virtual Counter Electromotive Force.** Effective C. E. M. F. in an alternating-current circuit.
- Virtual Current.**—The virtual amperes.
- Virtual Resistance.**—The apparent resistance of a circuit.
- Virtual Voltage.**—Voltage measured in an alternating-current circuit as the square root of the mean square of the value in volts, as obtained by a voltmeter calibrated by continuous currents.
- Virtual Work.**—In a system of bodies or material points, the amount of work which would be done by the force acting upon the bodies in an indefinitely small displacement, and which work vanishes when the system is in equilibrium.
- Viscous Hysteresis.**—(1) The time lag observed in magnetizing a bar of iron which is neither referable to the induction in the iron nor to self-induction in the magnetizing current, but to the magnetic viscosity of a substance. (2) A sluggishness exhibited by iron for magnetization or demagnetization, due to magnetic viscosity.
- Visual.**—Of or pertaining to vision.
- Visual Angle.**—An angle subtended between two lines drawn from an eye to opposite extremities of an object.
- Visual Clearing-Indicator.**—(1) An indicator at a telephone exchange for informing the operator that a conversation has ended, by the lighting up of a little incandescent lamp through a relay contact. (2) A clearing indicator appealing to the eye, as distinguished from an indicator which releases a drop.
- Visual Telegraphic Signals.**—Telegraphic signals that can be seen, as distinguished from those which can be heard.
- Visual Telegraphy.**—(1) Any system of telegraphy whose receiving instruments give visual signals. (2) Needle telegraphy.
- Vis-Viva.**—(1) The energy stored in a moving body. (2) The measure of the amount of work that must be performed in order to bring a moving body to rest.
- Vitreous.**—Of or pertaining to glass.
- Vitreous Electricity.**—A term formerly employed for positive electricity.
- Vitreous Electrification.**—A term formerly employed for positive electrification.
- Vitrite.**—A variety of insulating substance.
- Volatilization, Electric.**—(1) A term sometimes used instead of electric evaporation. (2) The volatilization of a conductor under the influence of heat of electric origin.
- Volatilization of Electric Conductor.**—The deflagration of an electric conductor by electrically generated heat.
- Volcanic Lightning.**—The lightning discharges that attend most volcanic eruptions.
- Volt.**—(1) The practical unit of electromotive force. (2) Such an electromotive force as is induced in a conductor which cuts lines of magnetic flux at the rate of 100,000,000 per second. (3) Such an electromotive force as would cause a current of one ampere to flow against a resistance of one ohm. (4) Such an electromotive force as would charge a condenser of the capacity of one farad with a quantity of electricity equal to one coulomb. (5) 10^8 absolute electro-magnetic units of electromotive force.
- Volt-Ammeter.**—(1) A name sometimes given to any instrument capable of measuring either the volts or the amperes in a circuit, or both. (2) The measurer of the volt-amperes or watts. (3) A wattmeter.
- Volt-Ampere.**—The watt.
- Volt Box.**—The name sometimes given to a divided wire placed across the terminals of a voltmeter to be tested. (2) A name sometimes given to a resistance divided into such sections that any suitable fractional drop in potential in the entire resistance can be readily measured by a potentiometer.
- Volt Indicator.**—A name sometimes given to a voltmeter.
- Voltage.**—The value of the electromotive force or difference of potential of any part of a circuit, expressed in volts.
- Volta-Electric.**—Of or pertaining to voltaelectricity.
- Volta-Electric Induction.**—A term sometimes used for voltaic induction.
- Volta-Electricity.**—A word sometimes used for voltaic electricity.
- Volta-Electrometer.**—A word sometimes used for voltameter.
- Volta-Electrometric.**—Of or pertaining to a voltameter or to voltaic electricity.
- Volta-Electromotive Force.**—Voltaic electromotive force.
- Volta-Force.**—Contact force between different metals.

- Volta-Plast.**—An unnecessary word proposed for a voltaic battery, used in electroplating.
- Volta-Type.**—An unnecessary word proposed for electro-type.
- Volta's Law.**—The difference of potential between any two metals is equal to the sum of the difference of potential between the intervening substances in the contact series.
- Voltagraphy.**—An unnecessary word sometimes used for electro-typing.
- Voltaic Accumulator.**—A term sometimes used for a secondary cell.
- Voltaic Alternatives.**—(1) A term used in medical electricity for the sudden reversals in the polarity of the electrodes of a voltaic battery employed in electrotherapeutics. (2) An alternating current obtained from a voltaic battery by the use of a suitable commutator.
- Voltaic Arc.**—(1) A brilliant arc or bow of light which appears between the electrodes or terminals of a sufficiently powerful source of electricity, when placed in contact and then separated a short distance from each other. (2) The source of light of the electric arc-lamp.
- Voltaic Balance.**—An apparatus employed to measure the voltaic energy present in any aqueous solution by balancing the electromotive forces produced by two small zinc-platinum couples immersed in water and placed in series with the circuit of a sensitive galvanometer, so as to balance one another, and then applying a solution of the substance whose energy is to be measured to the liquid in one of the solutions.
- Voltaic Battery.**—The combination as a single source of a number of separate voltaic cells.
- Voltaic Battery Indicator.**—A device for indicating the condition of a voltaic battery.
- Voltaic Battery Protector.**—A device for automatically opening the circuit of a voltaic battery, whenever it becomes accidentally grounded.
- Voltaic Bow.**—A word sometimes used for a voltaic arc.
- Voltaic Capacity of Accumulator.**—A term sometimes applied to the storage capacity of an accumulator.
- Voltaic Cell.**—(1) The combination of two metals, or of a metal and a metalloid, which, when dipped into a liquid or liquids called electrolytes, and connected by a conductor, will produce a current of electricity. (2) A voltaic couple and its accompanying electrolytes.
- Voltaic Circle.**—A name formerly employed for voltaic cell or circuit.
- Voltaic Circuit.**—The path through which the current flows from a voltaic cell or battery through the translating devices and back again through the cell or battery.
- Voltaic Couple.**—Any two materials, generally dissimilar metals, which are capable of acting as an electric source when dipped into an electrolyte.
- Voltaic Coupler.**—Any device by means of which voltaic cells may be readily coupled or connected in different varieties of circuits.
- Voltaic Effect.**—The difference of potential observed at the point of contact of dissimilar metals.
- Voltaic Electricity.**—The difference of potential produced by a voltaic cell or battery.
- Voltaic Electromotive Force.**—A term sometimes used for the electromotive force generated at the electrodes of an electrolytic cell in contradistinction to the counter-electromotive force produced at such electrodes before polarization.
- Voltaic Elements.**—Two metals or substances which form a voltaic couple.
- Voltaic Endosmose.**—A term sometimes used for electric osmose or endosmose.
- Voltaic Force.**—A word sometimes used for voltaic electromotive force.
- Voltaic Heat Cell.**—A cell by means of which heat energy is changed or converted into electric energy.
- Voltaic Impulse.**—A word sometimes used for the electromotive impulse of a voltaic couple.
- Voltaic Induction.**—A word sometimes used for current induction.
- Voltaic Magnet.**—An unnecessary term sometimes employed for a solenoid or electro-magnetic helix.
- Voltaic Pair.**—A voltaic couple.
- Voltaic Pile.**—A word sometimes used for voltaic battery.
- Voltaism.**—(1) A word sometimes employed in electro-therapeutics for treatment by means of the voltaic current. (2) The production of electricity by means of voltaic couples.
- Voltameter.**—An electrolytic cell employed for measuring the quantity of electric current passing through it, by the amount of chemical decomposition affected in a given time.

- Voltameter Law.**—The amount of chemical action produced by electrolysis in any electrolyte is proportional to the quantity of electricity which passes through that electrolyte.
- Volta's Condensing Electroscope.**—An electroscope whose leaves are charged by means of a condenser, employed for the detection of feeble charges.
- Voltmeter.**—Any instrument employed for measuring differences of potential.
- Voltmeter Panel of Switchboard.**—The panel of a switchboard containing a voltmeter or voltmeters.
- Voltmeter Switch.**—A switch for readily and safely connecting a voltmeter with any one of a number of circuits whose pressures may have to be measured.
- Volume Density, Electric.**—The amount of electricity per unit of volume.
- Volume Density of Charge.**—The electric volume-density.
- Volume of Illumination.**—A term proposed for a total quantity of illumination comprised between a surface on a horizontal plane, and the locus of the extremities of ordinates drawn vertically to each part of that surface, in values representing the intensity of illumination at that point.
- Volume Specific Resistance.**—(1) The electric resistance of a cubic centimetre of material measured between opposite faces of the cube, and expressed in the C. G. S. absolute system of units. (2) Volume resistivity. (3) Specific resistance by volume as compared with the volume resistance of a standard substance.
- Volume Voltmeter.**—A voltmeter in which the quantity of current passing is determined by the volume of gas evolved.
- Volumetric Energy.**—(1) Energy per unit of volume. (2) The energy in any substance or space divided by the volume of the substance or space.
- Vortex Atom.**—A hypothetical vortex in the ether constituting an atom of a material substance.
- Vortex Cylinder.**—A cylindrically shaped vortex ring.
- Vortex Ether.**—An ether possessing inertia and capable of forming vortices like a frictionless liquid.
- Vortex Ring.**—(1) A ring of vortically moving matter. (2) A name sometimes given to a motion in the air or other gross matter, similar to that which is supposed to constitute a vortex atom.
- Vortex-Ring Field.**—The field of influence possessed by a vortex ring.
- Vortex Stream Lines.**—Stream lines in the ether or matter, constituting a vortex atom or ring.
- Vulca.**—A variety of insulating material.
- Vulcabeston.**—A variety of insulating substance composed of asbestos and rubber.
- Vulcanite.**—(1) A variety of vulcanized rubber, possessing high powers of insulation and specific inductive capacity. (2) Ebonite.
- Vulcanized Fibre.**—A variety of insulating material suitable for purposes requiring the highest insulation.
- Vulcanizing Wooden Poles.**—Subjecting poles to the action of heat while in a closed cylinder.

W

- W.**—A contraction for watt.
- W.**—A contraction for work.
- W.**—A contraction for weight.
- W.**—A contraction for physical energy, whether electrical, thermal, mechanical or chemical; or, in general, for the product of the force acting, and the distance through which it acts.
- W.**—A symbol for electric energy.
- W.**—A symbol proposed for moment of a couple.
- W. H. E.**—A contraction for watt-hour efficiency.
- W. P.**—A contraction for waterproof.
- w. h.**—An abbreviation for watt-hour, a practical unit of electric energy.
- Wall Box for Flush Switch.**—A box sunk in a wall for the reception of a flush switch.
- Wall Bracket.**—(1) An insulator bracket attached to a wall. (2) A more or less ornamental support for one or more incandescent lamps attached to the wall of a room, hall, or corridor.
- Wall Frame for Flush Switch.**—A term sometimes used for the wall box of a flush switch.
- Wall Plug.**—A plug provided for the insertion of a lamp or other electro-recep-

- tive device in a wall socket, thus connecting it with the lead.
- Wall Set.**—Telephone apparatus arranged for use when supported on or against a wall.
- Wall Socket.**—A socket placed in a wall and provided with openings for the insertion of a wall plug with which the ends of a flexible twin-lead are connected.
- Wand, Electric.**—A term sometimes used for an electrophorus in the form of a torch.
- Wandering of Electric Spark.**—A discharge possessing the appearance of a brilliant luminous globule, which moves slowly, in an irregular path, over the surface of the tin-foil on a condenser to which the terminals of a powerful rheostatic machine is placed, when a portion of the mica plate in the condenser is accidentally pierced.
- Wanted Station.**—A word sometimes employed for a station that is desired by a telephone subscriber.
- Ward.**—A term proposed for a line and direction in a line.
- Waring Anti-Induction Cable.**—A form of lead-covered anti-induction cable.
- Washer Plate.**—A buried metallic plate for supporting the tension of a stay-rod.
- Waste Magnetic Field.**—A term frequently employed for stray field.
- Watch-Case Telephone Receiver.**—A name sometimes given to a small telephone receiver in the shape of a watch-case.
- Watchman's Electric Clock.**—A name sometimes given to a watchman's electric register.
- Watchman's Electric Register.**—A clock device for permanently recording the time of a watchman's visit to each of the different localities he is required to visit at stated intervals.
- Water Battery.**—A battery formed of zinc-copper couples immersed in an electrolyte of ordinary water.
- Water-Cooled Transformer.**—A transformer that is cooled by the forced circulation of water through it.
- Water-Dropping Accumulator.**—A device for increasing the difference of potential between two electric charges, by the dropping of water through electrified funnels.
- Water-Dropping Collector.**—A term sometimes employed for a water-dropping accumulator.
- Water-Gramme-Degree Centigrade.**—
(1) A heat unit equal to the quantity of heat required to raise a gramme of water one degree Centigrade. (2) The small calorie.
- Water Horse-Power.**—A term employed by the Indian Government for a horse-power developed by falling water, and estimated as being equal to 15 cubic feet of water falling per second, through a distance of one foot.
- Water Telephone Transmitter.**—A telephone transmitter consisting of a jet of water issuing vertically downwards from a small orifice.
- Water-Level Alarm, Electric.**—(1) A device for electrically sounding an alarm when a water level varies materially from a given level. (2) A liquid-level alarm.
- Water-Pipe Resistance.**—The resistance which any pipe offers to the flow of water through it.
- Water-Proof Wire.**—Wire covered by a water-proof material.
- Water Pyrometer.**—A pyrometer employed for determining the temperature of a furnace, or other intense source of heat, by the increase in temperature of a known weight of water, into which a metal cylinder of a given weight has been put, after having been exposed for a given time to the source of heat to be measured.
- Water Rheostat.**—A rheostat whose resistance is obtained by means of a mass of water of fixed dimensions.
- Water-Tube Dead-Beat Suspension.**—A dead-beat suspension obtained for the mirror of a sensitive galvanometer by the resistance offered by water in a tube to the movement of a vane attached to the suspension axis.
- Water Voltaic Cell.**—A cell consisting of a couple immersed in ordinary water.
- Water Voltmeter.**—A name sometimes given to a dilute sulphuric acid voltmeter.
- Watt.**—(1) A unit of electric power. (2) A volt-ampere. (3) The power developed when 44.25 foot pounds of work are done in a minute, or 0.7375 foot-pound of work is done in a second.
- Watt Arc.**—A voltaic arc, the electric power of which is estimated in watts.
- Watt Balance.**—A form of electric balance suitable for measuring in watts the electric energy developed in any circuit.
- Watt Generator.**—A term sometimes employed for the power in watts that any electric source is capable of producing.
- Watt-Hour.**—(1) A unit of electric work.

- (2) A term employed to indicate the expenditure of an electric power of one watt for an hour.
- Watt-Hour Efficiency of Storage Battery.**—The ratio between the amount of electric work in watt-hours a battery will yield after being charged, and the amount of work in watt-hours expended in charging it.
- Watt-Hour Meter.**—A form of recording watt-meter.
- Wattless Component.**—A component of E. M. F. or current, in quadrature with the working component.
- Wattless Component of Current.**—(1) In an alternating-current circuit that component of the current which is in quadrature with the impressed E. M. F. and which, therefore, takes from or gives no energy to the circuit. (2) In an alternating-current circuit the product of the E. M. F. and the effective susceptance.
- Wattless Component of Electromotive Force.**—(1) In an alternating-current circuit, that component of the E. M. F. which is in quadrature with the current strength, and, therefore, does no work on the current. (2) In an alternating-current circuit the product of the current and the effective reactance.
- Wattless Current.**—(1) That component of an alternating electric current which is in quadrature with the pressure and which, therefore, does no work. (2) The idle current. (3) In an alternating-current circuit the product of the effective susceptance and the E. M. F.
- Wattless E. M. F.**—(1) The wattless component of E. M. F. in an alternating-current circuit. (2) The reactive E. M. F., as distinguished from the active E. M. F. of an alternating-current circuit. (3) In an alternating-current circuit, the product of the E. M. F. and the effective or apparent conductance.
- Wattless Magnetizing Current.**—(1) A component of the magnetizing current which consumes no power on the average. (2) That component of the current which flows through the primary of a transformer, which serves for magnetizing only, and which is in quadrature with the pressure, as distinguished from the component of magnetizing current which expends energy in the iron core.
- Wattmeter.**—An instrument for measuring the power in any circuit.
- Watt-Minute.**—(1) A unit of electric work. (2) An expenditure of electric power of one watt for one minute.
- Watt-Second.**—(1) A unit of electric work. (2) An expenditure of electric power of one watt for one second. (3) A joule.
- Wave.**—An oscillatory motion in an elastic medium, periodic in time.
- Wave Bisector.**—An electric chronograph for determining the current or potential in a telegraph circuit or line at any given small interval of time after the application of the sending current.
- Wave, Electric.**—An electric periodic disturbance in an elastic medium.
- Wave Form of Alternating Current.**—Any particular type of an alternating-current wave.
- Wave Form of Alternating Current.**—A graphical type of an alternating-current wave.
- Wave Winding.**—(1) Undulatory winding. (2) Continuous winding. (3) A winding which, when developed, has the form of a wave.
- Waves of Condensation and Rarefaction.**—(1) The alternate spheres of condensed and rarified air by means of which sound is propagated. (2) Sound waves.
- Way.**—A term sometimes employed for cable way.
- Way Lease.**—A permit obtained from the owner of a property for the erection of poles or other attachments for telephonic or telegraphic lines.
- Way Leave.**—A word sometimes used for way lease.
- Way Leave.**—(1) A right of way. (2) An easement.
- Way Line.**—A line communicating with way stations.
- Way Office Cut-Out.**—A cut-out employed for inserting or removing a way office in a telegraphic line, by the aid of a plug.
- Way Telegraphic Station.**—Any station intermediate between the terminal stations.
- Ways for Dynamo-Electric Machine.**—Slides on the base of a dynamo-electric machine for moving part of its frame.
- Weather Contact.**—(1) A weather cross. (2) A partial contact between wires owing to leakage in bad weather.
- Weather Cross.**—A contact or leak occurring in a telegraphic or other line during wet weather, from a defective action of the insulators.
- Weather Proof Insulation.**—A trade-name for a character of insulation consisting of one or more layers of braided

- material soaked in an insulating compound.
- Weather-Proof Wire.**—A wire provided with weather-proof insulation.
- Weber.**—(1) The practical unit of magnetic flux. (2) A unit of magnetic flux having the value of one absolute unit or line. (3) A term formerly employed for unit of current, but now replaced by ampere. (4) A term proposed by Clausius and Siemens, but not adopted, for a magnetic pole of unit strength.
- Weber Turns.**—Flux linkages in C. G. S. units of flux and the turns through which they pass.
- Weber's Theory of Diamagnetism.**—A theory which endeavors to account for the phenomena of diamagnetism on the assumption of originally magnetized particles, molecules, or atoms.
- Wedge Battery.**—In a telegraph station, a battery whose terminals are connected with a wedge for insertion in a jack.
- Wedge Cut-Out.**—A form of cut-out employed on telegraphic circuits.
- Weeding-Out of Harmonics by Electric Resonance.**—Gradually removing the upper harmonics from a complex-harmonic current by altering the natural period of the system, until it is in unison or resonance with the fundamental frequency.
- Weight of Observations.**—The relative numerical reliability of observations.
- Weight Efficiency of Transformer.**—The specific output or activity of a transformer.
- Weight Voltmeter.**—A voltmeter in which the quantity of current passing is determined by the difference of weight of the instrument after the current has passed for a given time.
- Weight Voltmeter.**—A voltmeter in which the potential difference to be measured is determined by the movement of a magnetic needle under the influence of the current, against the action of a weight.
- Weight-Per-Mile-Ohm.**—(1) A standard of conductivity of wires. (2) The weight per mile of a wire, multiplied by its resistance per mile at a given temperature.
- Welded Rail Bond.**—A rail bond effected by electrically welding together the ends of the rails.
- Welder.**—A name sometimes applied to an electric welder.
- Welding.**—Uniting, generally at a high temperature, two pieces of metal in one without the appearance of a junction.
- Welding Converter.**—A welding transformer.
- Welding, Electric.**—Effecting the welding union of metals by means of heat of electric origin.
- Welding Transformer.**—A step-down transformer employed in electric welding.
- Welsbach Burner.**—A form of incandescent mantle burner whose light is due to the incandescence under the action of a Bunsen flame of a mantle covered with refractory materials.
- Western Union Splice.**—A term sometimes employed for an American wire joint.
- Wheatstone's Electric Balance.**—A name sometimes given to an electric bridge or balance.
- Wheatstone's Electric Bridge.**—A Wheatstone's electric balance.
- Wheel Brush.**—A name given to any rotary brush.
- Wheel Printing Telegraph.**—A printing telegraph in which a printing wheel is employed.
- Whip.**—A vibrating contact-maker.
- Whirl, Electric.**—(1) A term employed to indicate the circular directions of the lines of magnetic force surrounding a conductor conveying an electric current. (2) A magnetic whirl.
- Whistle, Electric.**—An automatic electric whistle.
- Whistling Effect.**—(1) An effect produced with a carbon transmitter and telephone receiver in a line, such that if the transmitter be close to the receiver and then slightly jarred, a musical note will be emitted by the receiver which will react upon the transmitter and produce similar sounds in other receivers on the same circuit. (2) A means sometimes employed to call a subscriber's attention when his receiver has been accidentally left in the line circuit, instead of the bell.
- White.**—Containing all the frequencies of the sun's radiation.
- White Heat.**—A temperature of a heated body, at which it emits all visible frequencies from the red to the violet, and therefore glows with a white light.
- Wig-Wag Signalling.**—A term sometimes used for torch signalling.
- Wimshurst's Electrostatic Machine.**—A form of influence electric machine.

- Wind and Water Line of Telegraph Pole.**—The surface of a telegraph pole at the level of the ground, where it is exposed to the destructive action of air and water.
- Wind, Electric.**—The convection streams of air particles produced at the extremities of points attached to the surface of charged insulated conductors.
- Windage of Dynamo Armature.**—A term proposed for the air-gap between the armature and the pole-pieces of a dynamo. (Not in general use.)
- Winding Space.**—The space provided on an armature or magnet core for its magnetizing coils.
- Windings.**—A general name applied to the coils placed on an armature of a dynamo or motor, or on the core of an electro-magnet.
- Wind-Mill Electric.**—A term sometimes used for an electric flyer.
- Wind-Mill Meter.**—An alternating-current meter whose operation is dependent on the motion of a wind-mill, by currents of air set up by the heat emitted from a conductor through which the current to be measured is passing.
- Window Contact.**—A variety of burglar-alarm contact, by means of which an alarm bell is rung by a slight pressure against a blind contact, on any attempt from without, after the breaking of the glass in the window.
- Window-Tube Insulator.**—A tube of vulcanite, or other insulating material, provided for the insulation of a wire entering a room through a window.
- Wings.**—The conducting plates, flaps, or extensions, of an electric resonator or oscillator.
- Wipe Spark.**—A spark obtained from a spark coil by the wiping contact of a spring.
- Wiped Joint.**—(1) A wiped solder or plumber's joint. (2) A joint in the lead sheathing of a cable formed by adding free surface metal, as in a plumber's joint in lead pipes.
- Wiping Contact.**—A contact obtained by a wiping movement of one conductor against another.
- Wippe.**—An orthography sometimes employed for whip.
- Wire.**—(1) To provide with a conducting circuit. (2) To send a telegram.
- Wire.**—(1) A conductor that forms part of a circuit. (2) A telegram.
- Wire Core.**—A form of laminated core obtained by the use of a number of iron wires.
- Wire Drum.**—A drum for holding overhead wires in process of erection.
- Wire Dynamometer.**—A line dynamometer.
- Wire Finder.**—Any form of galvanometer used to locate or find the corresponding ends of different wires in a bunched cable.
- Wire-Grating Polarizer.**—A series of parallel wires set in a frame and employed for polarizing electro-magnetic waves.
- Wire Guard.**—A wire netting placed over an incandescent lamp chamber, acting as a guard or protection for it.
- Wire Holder.**—(1) A form of insulator suitable for holding or supporting a wire. (2) A reel or cross suitable for holding a roll of wire.
- Wire Joint.**—(1) Any joint connecting two pieces of line wire. (2) A telegraphic joint.
- Wire Rail-Bond.**—A bond between contiguous or opposite rails effected by means of a conducting wire.
- Wire Selector.**—A wire finder.
- Wire Shade-Guard.**—A wire guard provided for the shade of an incandescent lamp.
- Wire Shield for Incandescent Lamp.**—A wire lamp-guard.
- Wire Splice.**—A splice effected between two pieces of wire.
- Wire Terminals.**—Metal eyes for soldering to the ends of wires and for connections to switchboards.
- Wire-Wound Armature.**—An armature which is wound with wire, as distinguished from an armature wound with bars.
- Wired.**—Provided with a conducting wire or wires.
- Wireless Telegraphy.**—(1) A general term for any form of telegraphic communication which can be effected without wire circuits. (2) Induction telegraphy. (3) Conduction telegraphy through the medium of the earth.
- Wiring.**—(1) Placing or installing the wires required in any circuit. (2) Collectively, the wires or electric conductors employed in any circuit of electric distribution.
- Wood Mouldings, Electric.**—Mouldings of dried non-conducting wood provided with longitudinal grooves for the recep-

- tion and support of electric wires or conductors.
- Wood's Button-Repeater.**—A form of manual telegraphic repeater.
- Work.**—The product of the force by the distance through which it acts.
- Work, Electric.**—(1) The joule. (2) A volt-coulomb, or the work done by the passage of one conduct through one volt.
- Work-Meter.**—A word sometimes used for energy meter.
- Working Current.**—(1) In an alternating-current circuit, a name sometimes given to an active current, or that component of the current which is in phase with the pressure. (2) Any current in a circuit, which does work. (3) A current operating a translating device.
- Working Current of Motor.**—The active current of an alternating-current motor.
- Working Efficiency of Telegraphic Circuit.**—The variation or margin between the joint resistance of the line conductor and the resistance of the insulators supporting such conductor.
- Working Galvanometer-Constant.**—A term sometimes employed for galvanometer constant.
- Working Position of Switch.**—The position of a switch when closed.
- Working Speed of Cable.**—A term employed for the number of signals that can be sent over a cable in a given time.
- Working Substance of Storage Battery.**—A name sometimes given to the active material of a storage battery.
- Woven-Wire Dynamo or Motor Brushes.**—Gauze brushes for dynamos or motors.
- Wrapped Wire.**—Wire covered with a wrapping of insulating material.
- Wrecking Wagon for Trolley Line.**—A word sometimes used for repair wagon.
- Writing Error.**—In telegraphy an error made in writing a message.
- Writing Telegraph.**—A general name for the apparatus used in writing telegraphy.
- Writing Telegraphy.**—A species of facsimile telegraphy, by means of which the motions of a transmitting pen so vary the resistance of two lines connected with the receiving instrument, as to cause a receiving pen or stylus to reproduce them.

X

- X-Graph.**—A word sometimes employed for radiograph.
- X-Radiation.**—A term sometimes used for Roentgen radiation.
- X-Ray Field.**—The field of activity of X-rays.
- X-Ray Fluoroscopy.**—The study of fluoroscopic effects obtained by means of the X-rays.
- X-Ray Lamp.**—A lamp consisting essentially of a high-vacuum tube, the inner walls of which are covered with crystals of calcium tungstate or other fluorescent substance, which emits fluorescent light when exposed to X-rays.
- X-Ray Photograph.**—A term sometimes employed for radiograph.
- X-Ray Photography.**—Photography effected by means of the X-rays.
- X-Ray Picture.**—A term sometimes employed for radiograph.
- X-Ray Source.**—Any source capable of producing X-rays.
- X-Ray Transformer.**—A transformer employed for obtaining the high-potential discharges employed in Roentgen or X-ray tubes.
- X-Ray Transformer-Coil.**—A form of induction coil employed for the production of X-rays.
- X-Ray Tube.**—A name sometimes given to a Roentgen ray tube.
- X-Rays.**—(1) A name frequently given to X-radiation. (2) The invisible rays emitted by an electrically excited Crookes tube, and which are capable of penetrating many substances opaque to light, and of producing actinic or fluorescent effects. (3) The unknown rays emitted by an X-ray tube from some point, generally opposite the cathode, which receives cathode-ray bombardment.